

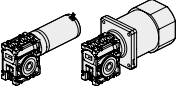





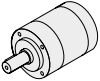

TRANSTECNO[®]
the modular gearmotor

ACDC
Robin
Small but Strong

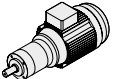
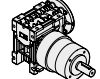

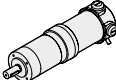
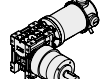
	<i>Indice</i>	<i>Index</i>	Pag. Page
	A INTRODUZIONE	INTRODUCTION	A1
	B MOTORIDUTTORI A VITE SENZA FINE ECM-ACM	WORMGEARMOTORS ECM-ACM	B1
 	C RIDUTTORI EPICICLOIDALI P	PLANETARY GEAR UNITS P	C1
 	D MOTORIDUTTORI CA EPICICLOIDALI ACP	AC PLANETARY GEARMOTORS ACP	D1
	E RIDUTTORI COMBINATI IN CA WMP	AC DOUBLE REDUCTION GEARMOTORS WMP	E1
 	F MOTORIDUTTORI CC EPICICLOIDALI A MAGNETI PERMANENTI IN NEODIMIO NDP	NEODYMIUM PERMANENT MAGNETS DC PLANETARY GEARMOTORS NDP	F1
	G MOTORIDUTTORI CC COMBINATI A MAGNETI PERMANENTI IN NEODIMIO NDWMP	NEODYMIUM PERMANENT MAGNETS DC DOUBLE REDUCTION GEARMOTORS NDWMP	G1
 	H MOTORIDUTTORI CC EPICICLOIDALI A MAGNETI PERMANENTI IN FERRITE ECP	FERRITE PERMANENT MAGNETS DC PLANETARY GEARMOTORS ECP	H1
	I MOTORIDUTTORI CC COMBINATI A MAGNETI PERMANENTI IN FERRITE ECWMP	FERRITE PERMANENT MAGNETS DC DOUBLE REDUCTION GEARMOTORS ECWMP	I1
	L AZIONAMENTI PER MOTORI CC PLN	DC MOTOR CONTROLS PLN	L1

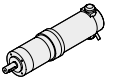
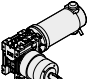
Indice	Index	Pag. Page
Generalità	<i>General information</i>	A2
Velocità entrata	<i>Input speed</i>	A2
Rapporto di riduzione	<i>Gear ratio</i>	A2
Velocità in uscita	<i>Output speed</i>	A2
Coppia richiesta	<i>Requested torque</i>	A2
Coppia nominale	<i>Nominal torque</i>	A3
Coppia trasmessa	<i>Output torque</i>	A3
Rendimento del riduttore a vite senza fine	<i>Worm gearbox efficiency</i>	A3
Reversibilità e irreversibilità	<i>Reversibility and irreversibility</i>	A4
Potenza in entrata	<i>Input power</i>	A4
Fattore di servizio	<i>Service factor</i>	A5
Carico radiale	<i>Radial load</i>	A6
Carico assiale	<i>Axial load</i>	A6
Scelta dei motoriduttori	<i>Selecting the gearmotors</i>	A6
Installazione e verifiche	<i>Installation and inspection</i>	A8
Applicazioni critiche	<i>Critical applications</i>	A8

Questa sezione annulla e sostituisce ogni precedente edizione o revisione. Qualora questa sezione non Vi sia giunta in distribuzione controllata, l'aggiornamento dei dati ivi contenuto non è assicurato. **In tal caso la versione più aggiornata è disponibile sul nostro sito internet www.transtecno.com**

*This section replaces any previous edition and revision. If you obtained this catalogue other than through controlled distribution channels, the most up to date content is not guaranteed. **In this case the latest version is available on our web site www.transtecno.com***

Generalità

Per avere una migliore comprensione degli argomenti e dei dati esposti in questo catalogo proponiamo la simbologia utilizzata corredandola delle informazioni di base per giungere ad una corretta selezione dei motorriduttori e variatori.

General information

Information in this manual is provided with symbols in order to understand the subject matter and data. These symbols are intended to aid the user in selecting the right gearmotors and variators.

Velocità entrata **n_1 [min⁻¹]****Input speed**

Rappresenta la velocità riferita al tipo di motorizzazione prescelta ed è applicata in entrata al riduttore.

This is the input speed at the gearbox related to the type of drive unit selected.

Per selezioni a velocità diverse da quelle riportate consultare il ns. Servizio Tecnico.

When different speeds are required, contact our Technical Service.

Rapporto di riduzione **i** **Gear ratio**

È una grandezza adimensionale ed è in funzione del numero dei denti degli ingranaggi interni al riduttore.

This value is strictly related to the size and number of teeth gears inside the gearbox.

Nei riduttori a vite senza fine si ottiene dividendo il numero di denti della corona per il numero dei filetti (Z) della vite senza fine.

This value is obtained in wormgearboxes by dividing the number of wheel teeth by the number of starts (Z) of the worm.

Dai dati di catalogo si può ottenere con la relazione:

From the data given in the catalogue, the value can be calculated using the following formula:

$$i = \frac{n_1}{n_2}$$

Velocità in uscita **n_2 [min⁻¹]****Output speed**

È la velocità risultante sull'asse di uscita del riduttore e viene ricavata dalla relazione precedente:

This is the gearbox output speed calculated using the formula given above:

$$n_2 = \frac{n_1}{i}$$

Coppia richiesta **Mr_2 [Nm]****Requested torque**

È la coppia richiesta dall'applicazione ed è indispensabile per la selezione di una motorizzazione.

This is the torque needed for the application and must be known when selecting a drive system. It can either be provided by the user or calculated according to the application data (if provided).

Essa può essere comunicata dall'utente oppure calcolata in base ai dati di applicazione (se forniti).

Coppia nominale

Mn₂ [Nm]

Nominal torque

Rappresenta la coppia in uscita trasmissibile dal riduttore in base alla velocità in entrata n₁ e al rapporto di riduzione i. Essa è calcolata in base ad un servizio con carico continuo uniforme corrispondente ad un fattore di servizio uguale a 1. Questo valore non è riportato nel presente catalogo ma può essere ricavato approssimativamente con la seguente relazione fra M₂ (coppia trasmessa) e sf (fattore di servizio):

This is the output torque that can be transmitted by the gearbox according to input speed n₁ and gear ratio i. It is calculated based on service with a continuous steady load corresponding to a service factor equal to 1. This value is not given in the catalogue but can be calculated approximately with the following formula between M₂ (output torque) and sf (service factor):

$$Mn_2 = M_2 \cdot sf$$

Coppia trasmessa

M₂ [Nm]

Output torque

È la coppia trasmessa in uscita al riduttore. Dipende dalla potenza P₁ del motore installato, dal numero di giri in uscita n₂ e dal rendimento dinamico Rd e può essere calcolata con la relazione:

This is the gearbox's output torque. It is strictly related to power P₁ of the motor installed, output rpm n₂ and dynamic efficiency Rd. It can be calculated with the following formula:

$$M_2 = \frac{9550 \cdot P_1 \cdot Rd}{n_2}$$

oppure:
or:

$$M_2 = \frac{9550 \cdot P_2}{n_2}$$

dove:
where:

$$P_2 = P_1 \cdot Rd$$

Rendimento del riduttore a vite senza fine

Rd; Rs

Worm gearbox efficiency

I calcoli delle prestazioni sono stati effettuati in base al rendimento dinamico Rd dei riduttori (valore ottimale che si raggiunge nel funzionamento a regime dopo rodaggio).

Efficiency is calculated based on dynamic efficiency Rd of the gearboxes (optimal value reached when running at normal speed after the break in period).

È opportuno considerare che nei riduttori a vite senza fine si ha anche un valore di rendimento statico Rs, presente in fase di avviamento, che declassa sensibilmente la coppia risultante per cui influenza in modo determinante la scelta di motorizzazioni destinate ad applicazioni intermittenti (es. sollevamenti).

It is important to remember that wormgearboxes also have static efficiency value Rs present at start-up. This value notably reduces the resulting torque. As a result, it must be taken into consideration when selecting drive systems for intermittent operations (e.g. lifting) as it is a determinant factor.

Reversibilità e irreversibilità

Reversibility and irreversibility

La diretta conseguenza del rendimento (statico e dinamico) è la reversibilità del riduttore a vite senza fine che consiste nella possibilità di fare ruotare l'albero entrata tramite l'applicazione di una torsione più o meno accentuata sull'albero uscita.

L'impossibilità o la difficoltà ad effettuare l'azione sopra descritta, determina il grado di reversibilità (o irreversibilità) di un riduttore.

Questa caratteristica, molto significativa nei riduttori a vite senza fine, è influenzata da molteplici fattori quali angolo d'elica (quindi rapporto di trasmissione), lubrificazione, temperatura, finitura superficiale della vite senza fine, presenza di vibrazioni, ecc.

In applicazioni dove sono presenti delle traslazioni è necessario garantire una elevata reversibilità onde evitare che le inerzie delle masse in movimento possano determinare punte di carico inammissibili sugli organi di trasmissione.

In applicazioni dove è richiesto un non ritorno del carico (es. sollevamenti o nastri trasportatori inclinati) in assenza di un freno motore è necessario scegliere un riduttore caratterizzato da un elevato grado di irreversibilità.

Desideriamo comunque evidenziare che la garanzia assoluta di non ritorno è data esclusivamente dall'installazione di un motore autofrenante o di un altro dispositivo frenante esterno.

La tabella sottostante riporta a titolo puramente indicativo i vari gradi di reversibilità/irreversibilità nei riduttori a vite senza fine in funzione del rendimento dinamico Rd e statico Rs.

Reversibility of the wormgearbox is the direct consequence of efficiency (static and dynamic). This determines whether or not the input shaft can be rotated by applying a certain torque on the output shaft.

Whether or not this can be done and how difficult it actually is to do determine the degree of reversibility (or irreversibility) of a gearbox.

This feature, quite significant in wormgearboxes, is affected by numerous factors including the helix angle (therefore drive ratio), lubrication, temperature, surface finish of the worm, vibrations, etc...

In applications that include translations, high reversibility must be guaranteed to prevent inertia of the moving parts from creating unacceptable load peaks on the drive parts.

In applications that require non-return of the load (e.g. lifting or inclined conveyor belts) a gearbox with high irreversibility must be chosen when a motor-brake unit is not present.

However, we would like to point out that non-return can be totally assured only by installing a self-braking motor or other external braking device.

The table below is provided for reference purposes only. It contains the various degrees of reversibility/irreversibility of wormgearboxes in relation to dynamic Rd and static Rs efficiency.

Rd	Reversibilità e irreversibilità dinamica	Dynamic reversibility and irreversibility
> 0.6	Reversibilità dinamica	Dynamic reversibility
0.5 - 0.6	Reversibilità dinamica incerta	Uncertain dynamic reversibility
0.4 - 0.5	Buona irreversibilità dinamica	Good dynamic irreversibility
<0.4	Irreversibilità dinamica	Dynamic irreversibility
Rs	Reversibilità e irreversibilità statica	Static reversibility and irreversibility
> 0.55	Reversibilità statica	Static reversibility
0.5 - 0.55	Reversibilità statica incerta	Uncertain static reversibility
<0.5	Irreversibilità statica	Static irreversibility

Potenza in entrata

P₁ [kW]

Input power

È la potenza motore applicata in entrata al riduttore e riferita alla velocità n₁.

Può essere calcolata come segue:

This is the power applied by the motor at the gearbox input in reference to speed n₁.

It can be calculated with the following formula:

$$P_1 = \frac{M_2 \cdot n_2}{9550 \cdot Rd}$$

Fattore di servizio

sf

Service factor

È una grandezza adimensionale che indica il sovradimensionamento da applicare ad una determinata motorizzazione per garantire la resistenza agli urti e la durata richiesta.

Le tabelle di catalogo offrono una vasta scelta di motorizzazioni con fattori di servizio differenziati che possono soddisfare la maggior parte delle applicazioni più o meno gravose.

Per una corretta interpretazione dei valori del fattore di servizio sf riportati a fianco di ogni selezione proposta, riportiamo nelle tabelle seguenti i valori indicativi attribuiti alle classi di carico A, B, C e alla durata di funzionamento giornaliero h/d e al numero di avviamenti/ora.

Definendo la classe di carico a cui riferire l'applicazione, si ricercherà nella tabella il corrispondente valore di sf da utilizzare nella scelta della motorizzazione più idonea.

This value indicates how a certain drive system is to be over-sized in order to assure the requested service and stand up to shocks.

The tables given in the catalogue offer a wide range of drive systems with different service factors able to satisfy most types of applications. To correctly understand service factor values sf given for each item, approximate values for load classes A, B and C along with the number of hours of daily operation h/d and number of start-ups/hours need to be known.

Once the load class required for the application has been determined, locate corresponding value sf to be used when selecting the most suitable drive system.

A - Uniforme	$fa \leq 0.3$
B - Medio	$fa \leq 3$
C - Forte	$fa \leq 10$

A - Uniform	$fa \leq 0.3$
B - Moderate shocks	$fa \leq 3$
C - Heavy shocks	$fa \leq 10$

$fa = \frac{Je}{Jm}$

- Je (kgm²) momento d'inerzia esterno ridotto all'albero motore.
- Jm (kgm²) momento d'inerzia motore.

Se $fa > 10$ interpellare il ns. Servizio Tecnico.

$fa = \frac{Je}{Jm}$

- Je (kgm²) moment of reduced external inertia at the drive-shaft.
- Jm (kgm²) moment of inertia of motor.

If $fa > 10$ call our Technical Service.

A Classe di carico / Load class
Carico uniforme / Uniform load

		sf								
		n. avviamenti/ora / n. start-up/hour								
h/d	2	4	8	16	32	63	125	250	500	
4	0.8	0.8	0.9	0.9	1.0	1.1	1.1	1.2	1.2	
8	1.0	1.0	1.1	1.1	1.3	1.3	1.3	1.3	1.3	
16	1.3	1.3	1.3	1.3	1.5	1.5	1.5	1.5	1.5	
24	1.5	1.5	1.5	1.5	1.8	1.8	1.8	1.8	1.8	

B Classe di carico / Load class
Carico con urti moderati / Moderate shock load

		sf								
		n. avviamenti/ora / n. start-up/hour								
h/d	2	4	8	16	32	63	125	250	500	
4	1.0	1.0	1.0	1.0	1.3	1.3	1.3	1.3	1.3	
8	1.3	1.3	1.3	1.3	1.5	1.5	1.5	1.5	1.5	
16	1.5	1.5	1.5	1.5	1.8	1.8	1.8	1.8	1.8	
24	1.8	1.8	1.8	1.8	2.2	2.2	2.2	2.2	2.2	

C Classe di carico / Load class
Carico con urti forti / Heavy shock load

		sf								
		n. avviamenti/ora / n. start-up/hour								
h/d	2	4	8	16	32	63	125	250	500	
4	1.3	1.3	1.3	1.3	1.5	1.5	1.5	1.5	1.5	
8	1.5	1.5	1.5	1.5	1.8	1.8	1.8	1.8	1.8	
16	1.8	1.8	1.8	1.8	2.2	2.2	2.2	2.2	2.2	
24	2.2	2.2	2.2	2.2	2.5	2.5	2.5	2.5	2.5	

Esempio applicazione:

Nastro trasportatore attribuibile alla classe di carico B (**carico con urti moderati**) e previsto per una durata di funzionamento giornaliero (h/d) di **16** ore e con **8** avviamenti/ora. Dalla tabella rileviamo **sf = 1.5**

Application example:

Conveyor belt assigned to load class B (**moderate shock load**), to be run **16** hours a day (h/d) with **8** start-ups/hour. The following value is obtained from the table **sf = 1.5**

Carico radiale

R; R₂ [N]

Radial load

L'applicazione sull'albero in uscita del riduttore di pignoni, pulegge, ecc. determina delle forze radiali che debbono necessariamente essere considerate per evitare sollecitazioni eccessive con il rischio di danneggiamenti del riduttore stesso.

Pinions, pulleys, etc applied on the output shaft of the gearboxes create radial forces that must be taken into consideration to avoid excessive stress risking damage to the gearbox itself.

Il calcolo del carico radiale esterno R agente sull'albero del riduttore può essere determinato come segue:

External radial load R that acts on the gearbox shaft can be calculated as follows:

$$R = \frac{2000 \cdot M_2 \cdot kr}{d} \leq R_2$$

dove:

d [mm] diametro primitivo del pignone o della puleggia
kr coefficiente riferito al tipo di trasmissione:
kr = 1.4 ruota per catena
kr = 1.1 ingranaggio
kr = 1.5 - 2.5 puleggia per cinghia a V

where:

d [mm] diameter of the pinion or pulley
kr coefficient in relation to type of transmission:
kr = 1.4 sprocket wheel
kr = 1.1 gear
kr = 1.5 - 2.5 pulley for V belts

È opportuno evidenziare che i valori di R₂ sono riferiti a carichi agenti sulla mezzeria dell'albero lento (considerando l'albero sporgente) per cui il confronto dovrà essere effettuato nelle medesime condizioni.

Keep in mind that values R₂ refer to loads that act on the center-line of the output shaft (considering the shaft protrudes). As a result, the value should be compared under the same conditions.

Carico assiale

A; A₂ [N]

Axial load

A volte, unitamente al carico radiale, può essere presente anche una forza A che agisce assialmente sull'albero uscita; in questo caso considerare che il carico assiale ammissibile A₂ sull'albero è da considerare:

At times, along with the radial load, force A may be present that acts axially on the output shaft. In this case, keep in mind allowable axial load A₂ that can be applied on the shaft is:

$$A_2 = R_2 \cdot 0.2$$

Nel caso in cui il valore del carico assiale A agente sull'albero risultasse superiore ad A₂ contattate il ns. Servizio Tecnico.

If axial load A that acts on the shaft is greater than A₂, contact the Technical Service.

Scelta dei motoriduttori

Selecting the gearmotors

Per la scelta di un motoriduttore è necessario seguire la seguente procedura.

To select the required gearmotor perform the procedure below:

1. Per l'applicazione desiderata ricavare il fattore di servizio sf dalle tabelle a pag. A5 in base alla classe di carico, alle ore di funzionamento giornaliere e al numero di avviamenti orari.
2. Se si conosce la potenza motore P₁ [kW] richiesta, passare al punto 3); se è nota la coppia in uscita M₂ richiesta è necessario calcolare la potenza motore P₁ con la formula:

1. Determine the service factor sf for the desired application by referring to the charts given on page A5. This is to be done by considering the class of load, the operational hours/day and the number of start-ups/ hour.
2. If the required motor power output P₁ [kW] is known, go to item 3); if the required output torque M₂ is known, determine motor output P₁ by using the following formula:

$$P_1 = \frac{M_2 \cdot n_2}{9550 \cdot Rd}$$

dove Rd è il rendimento dinamico e n₂ il numero di giri richiesti in uscita al motoriduttore.

where Rd stands for the dynamic efficiency and n₂ indicates the required output rpm of the gearmotor.

3. Nelle tabelle dei dati tecnici ricercare la motorizzazione in cui sia P_1 maggiore o uguale a P e con riferimento ad una velocità n_2/n_{2max} prossima a quella desiderata, scegliere la motorizzazione in cui il fattore di servizio sf indicato risulta uguale o superiore a quello ricavato al punto 1).

3. Use the specification chart to search for the power unit where P_1 is greater than or equal to P with a speed n_2/n_{2max} that approximates the desired one. Choose a power unit where the indicated service factor sf is equal to or greater than that calculated at point 1).

ECM

P_1 [W]	n_2 [min ⁻¹]	M_2 [Nm]	sf	i		Versione motore Motor version
70						
(3000 min ⁻¹)	600	1.0	10.1	5	ECM050/026	120/240
	400	1.5	7.6	7.5		
	300	1.9	5.8	10		
	200	2.8	4.0	15		
	150	3.6	3.1	20		
	100	4.9	2.5	30		
	75	6.1	1.8	40		
	60	7.1	1.4	50		
	50	8.0	1.1	60		

Esempio / Example:

Applicazione / Application:

Carrello automatico / Automatic carriage

P_1 : 70 W
sf : 3.1
 n_2 : 150 min⁻¹

Motorizzazione scelta / Power unit selected:

ECM050/026, i = 20, P_1 = 70 W, sf = 3.1

ECP

P_1 [W]	n_2 [min ⁻¹]	M_2 [Nm]	sf	i		Versione Version
500						
(3000 min ⁻¹)	218	16.2	1.5	13.73	ECP350/622	120/240
	189	18.7	1.3	15.88		
	163	21.6	1.2	18.36		
	156	22.6	1.1	19.20		
	135	26.1	1.0	22.20		
	120	29.4	0.8	25.01		
	112	31.6	0.8	26.85		
	104	34.1	0.7	28.93		
	86	35.7	0.7	34.97		
	66	35.7	0.7	45.56		

Esempio / Example:

Applicazione / Application:

Carrello automatico / Automatic carriage

P_1 : 500 W
sf : 1.5
 n_2 : 218 min⁻¹

Motorizzazione scelta / Power unit selected:

ECP350/622, i = 13.73, P_1 = 500 W, sf = 1.5

Installazione e verifiche

In fase di installazione del motoriduttore è opportuno verificare che:

- i dati riportati in targhetta corrispondano al prodotto che è stato ordinato;
- le superfici di accoppiamento e gli alberi siano accuratamente puliti e privi di ammaccature;
- le superfici su cui verrà installato il riduttore siano perfettamente piane e sufficientemente rigide;
- l'albero macchina e quello del riduttore siano correttamente allineati;
- siano stati installati sistemi di limitazione della coppia se si prevedono urti o blocchi della macchina durante il funzionamento;
- siano state predisposte le necessarie protezioni antinfortunistiche agli organi rotanti;
- siano state create delle opportune coperture a protezione dagli agenti atmosferici se l'installazione è effettuata all'aperto ed è soggetta alle intemperie;
- l'ambiente di lavoro non sia corrosivo (a meno che tale specifica non sia stata dichiarata in fase di ordine al fine di predisporre il riduttore per questo utilizzo);
- gli eventuali pignoni o pulegge montati sull'albero uscita o entrata del riduttore, siano calettati correttamente in modo tale da non generare carichi radiali e/o assiali superiori a quelli ammissibili;
- su tutti gli accoppiamenti sia stato applicato un adeguato protettivo antiossidante per prevenire eventuali ossidazioni da contatto;
- tutte le viti di fissaggio siano state serrate correttamente.

Installation and inspection

While installing the gearmotor always make sure that:

- *the specifications stamped on the rating plate match those indicated for the unit actually ordered;*
- *the mating surfaces and the shafts are thoroughly clean and free of dents;*
- *the surfaces where the gearbox are to be mounted on are flat and strong enough;*
- *the machine drive shaft and the gearbox shaft are perfectly aligned;*
- *the required torque limiters have been installed if the machine is likely to produce shocks or blockages during operation;*
- *the rotary parts have been provided with the required safety guards;*
- *adequate weatherproof covering has been provided if the machine is to be installed outdoor;*
- *the working environment is not exposed to corrosive agents (unless this has been indicated while placing the order so that the gearbox assembly can be adequately set up);*
- *the pinions or pulleys on the gearbox input/output shafts are properly fitted in order not to produce radial and/or axial loads that exceed the maximum allowable limits;*
- *all the couplings have been treated with adequate rust preventative in order to avoid oxidation provoked by contact;*
- *all the mounting screws have been securely tightened.*

Applicazioni critiche

In tutti questi casi consultare il Servizio Tecnico

- utilizzo come organo di sollevamento;
- utilizzo in posizioni non previste a catalogo;
- utilizzo in ambiente con pressione diversa da quella atmosferica;
- utilizzo in ambiente con temperature $<0^{\circ}\text{C}$ o $>+40^{\circ}\text{C}$;
- utilizzo in ambienti esterni

Critical applications

In these cases please contact the Technical Service

- *used as a hoist;*
- *used in mounting positions not shown in the catalogue;*
- *used in environment pressure other than atmospheric pressure;*
- *used in places with temperature $<0^{\circ}\text{C}$ or $>+40^{\circ}\text{C}$;*
- *when used outdoors*



Motoriduttori a vite senza fine Wormgearmotors

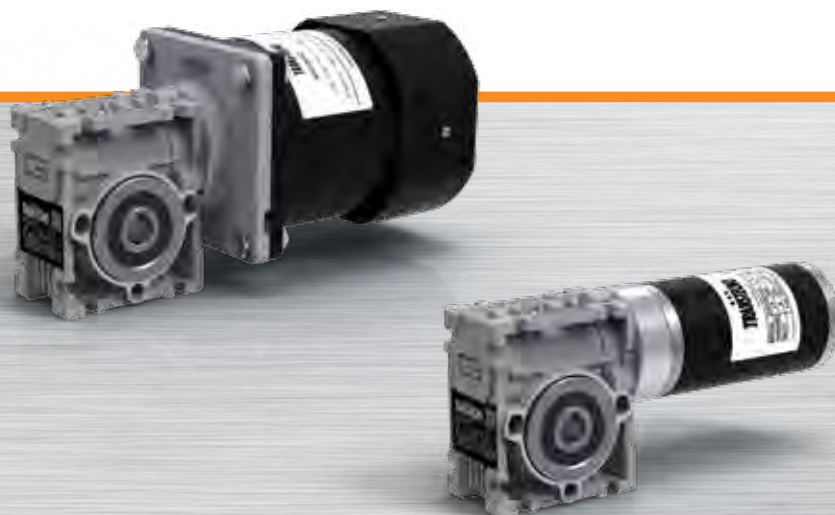

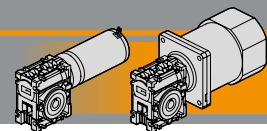

Indice	Index	Pag. Page
Caratteristiche tecniche	<i>Technical features</i>	B2
Designazione	<i>Classification</i>	B2
Simbologia	<i>Symbols</i>	B2
Lubrificazione	<i>Lubrication</i>	B3
Carichi radiali	<i>Radial loads</i>	B3
Dati di dentatura	<i>Toothing data</i>	B4
Rendimento	<i>Efficiency</i>	B4
Dati tecnici	<i>Technical data</i>	B5
Dimensioni ECM	<i>ECM Dimensions</i>	B6
Dimensioni ACM	<i>ACM Dimensions</i>	B8
Accessori	<i>Accessories</i>	B11

Questa sezione annulla e sostituisce ogni precedente edizione o revisione. Qualora questa sezione non Vi sia giunta in distribuzione controllata, l'aggiornamento dei dati ivi contenuto non è assicurato. **In tal caso la versione più aggiornata è disponibile sul nostro sito internet www.transtecno.com**

*This section replaces any previous edition and revision. If you obtained this catalogue other than through controlled distribution channels, the most up to date content is not guaranteed. **In this case the latest version is available on our web site www.transtecno.com***

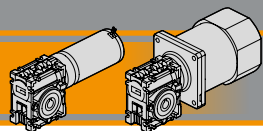

Caratteristiche tecniche

Technical features

Le caratteristiche principali dei motoriduttori a vite senza fine della gamma Robin sono:

The main features of Robin wormgearmotors range are:

- Alimentazione in bassa tensione (12/24 Vcc) per la serie ECM; corrente alternata monofase (230 Vca - 50Hz) o corrente alternata trifase (400 Vca - 50Hz) per la serie ACM
- Potenze motore disponibili da 40 a 70 W
- Carcasse dei riduttori in pressofusione di alluminio
- Lubrificazione permanente con olio sintetico
- Elevata affidabilità in ingombri molto ridotti
- Supply voltage 12/24Vdc for ECM range, single phase 230Vac-50Hz or three phase 400Vac-50Hz for ACM range
- Motor power available from 40W to 70W
- Die-cast aluminum housing for wormgearboxes
- Permanent synthetic oil long-life lubrication
- Reliable and compact

Designazione

Classification

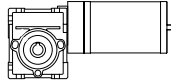
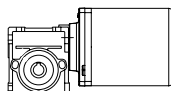
MOTORIDUTTORE / GEARMOTOR								
ECM	050/026	U	10	SZDX	BRSX	90	240	BR
Tipo Type	Grandezza Size	Versione Riduttore Gearbox Version	Rapporto Ratio	Albero di uscita Output shaft	Braccio di reazione Torque arm	Angolo Angle	Versione Motore Motor Version	Versione Motore Motor Version
ECM 	035/026 035/030 050/026 050/030	U FD FS	Vedere tabella <i>See tables</i>	SZDX SZSX DZ	BRDX BRSX	0° 90° 180° 270°	120	BR
ACM 	040/026 040/030 060/026 060/030						230/1 400/3 <i>230/3 a richiesta on request</i>	BRL

Versione Riduttore
Gearbox Version

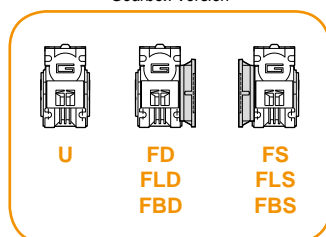

Albero di uscita
Output shaft

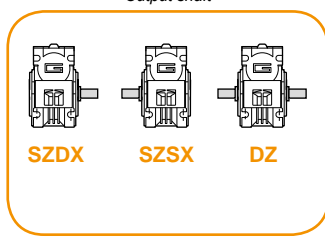

Braccio di reazione
Torque arm

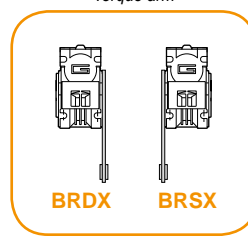

Angolo
Angle

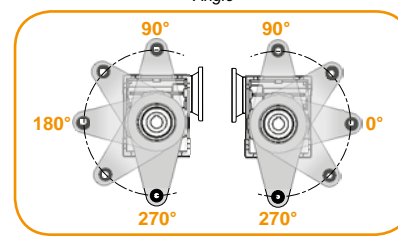

Simbologia

Symbols

n_1 [min ⁻¹]	Velocità in ingresso / <i>Input speed</i>	R_d %	Rendimento dinamico / <i>Dynamic efficiency</i>
n_2 [min ⁻¹]	Velocità in uscita / <i>Output speed</i>	A_2 [N]	Carico assiale ammissibile in uscita / <i>Permitted output axial load</i>
i	Rapporto di riduzione / <i>Ratio</i>	R_s %	Rendimento statico / <i>Static efficiency</i>
P_1 [kW]	Potenza in entrata / <i>Input power</i>	R_2 [N]	Carico radiale ammissibile in uscita / <i>Permitted output radial load</i>
M_2 [Nm]	Coppia in uscita in funzione di P_1 / <i>Output torque referred to P_1</i>	Z	Numero di principi della vite / <i>Worm starts</i>
sf	Fattore di servizio / <i>Service factor</i>	β	Angolo d'elica / <i>Helix angle</i>

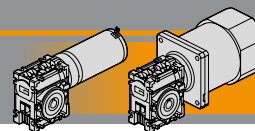

Lubrificazione

Lubrication

I riduttori a vite senza fine sono lubrificati a vita con olio sintetico viscosità 320 (-35°C +50°C), possono essere installati in qualunque posizione di montaggio e non necessitano di manutenzione.

Permanent synthetic oil long-life lubrication viscosity grade 320 (-35°C +50°C) allows the wormgearboxes to be installed in all mounting positions and to be maintenance free.

Carichi radiali

Radial loads

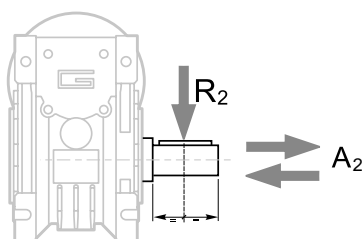

$$A_2 = R_2 \times 0.2$$

n ₂ [min ⁻¹]	R ₂ [N]	
	CM026	CM030
187	400	674
140	490	743
93	580	851
70	610	936
56	610	1008
47	610	1069
35	610	1179
28	610	1270
23	610	1356
18	610	1471
14	610	1600

Quando il carico radiale risultante non è applicato sulla mezza-ria dell'albero occorre calcolare quello effettivo con la seguente formula:

When the resulting radial load is not applied on the centre line of the shaft it is necessary to calculate the effective load with the following formula:

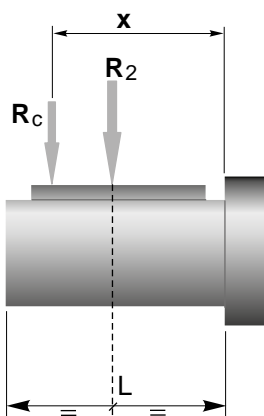

$$R_c = \frac{R_2 \cdot a}{(b+x)} \leq R_{2MAX}$$

$$R \leq R_c$$

a, b = valori riportati nella tabella
a, b = values given in the table

	CM	
	026	030
a	56	65
b	43	50
R _{2MAX}	610	1600

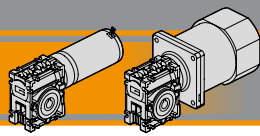

Dati di dentatura

Toothing data

	Dati della coppia vite-corona Worm wheel data	Rapporto / Ratio											
		5	7.5	10	15	20	25	30	40	50	60	80	100
CM026	Z	6	4	3	2	2		1	1	1	1		
	β	34° 35'	24° 41'	19° 1'	12° 57'	10° 30'		6° 33'	5° 17'	4° 26'	3° 49'		
CM030	Z	6	4	3	2	2	2	1	1	1	1	1	1
	β	27° 4'	24° 28'	18° 50'	12° 49'	10° 23'	8° 43'	6° 29'	5° 14'	4° 23'	3° 46'	2° 57'	2° 25'

Rendimento

Efficiency

	n_1 [min ⁻¹]	Rendimento Efficiency	Rapporto / Ratio											
			5	7.5	10	15	20	25	30	40	50	60	80	100
CM026	2800	Rd	89	87	85	83	80		73	68	64	60		
	1400		87	84	83	78	74		66	61	57	53		
	900		84	83	80	75	71		61	57	52	48		
		Rs	72	71	68	61	56		46	41	36	34		
CM030	2800	Rd	89	88	86	84	81	78	74	70	65	62	57	52
	1400		86	85	84	79	75	72	67	62	58	55	48	43
	900		84	83	81	75	71	68	62	58	53	49	43	39
		Rs	72	67	63	55	50	43	39	35	31	27	23	21





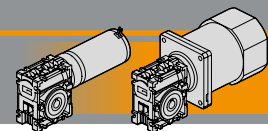



Rendimento teorico del riduttore dopo il rodaggio
Theoretical efficiency of the gearbox after the first running period



Dati tecnici ECM

DC







Technical data ECM

P_1 [W]	n_2 [min ⁻¹]	M_2 [Nm]	sf	i		Versione motore Motor version	P_1 [W]	n_2 [min ⁻¹]	M_2 [Nm]	sf	i		Versione motore Motor version							
55							70													
(3000 min ⁻¹)	600	0.8	12.8	5		ECM035/026	120/240	(3000 min ⁻¹)	600	1.0	10.1	5		ECM050/026	120/240					
	400	1.1	9.6	7.5							400	1.5				7.6	7.5			
	300	1.5	7.4	10							300	1.9				5.8	10			
	200	2.2	5.0	15							200	2.8				4.0	15			
	150	2.8	3.9	20							150	3.6				3.1	20			
	100	3.8	3.1	30							100	4.9				2.5	30			
	75	4.8	2.3	40							75	6.1				1.8	40			
	60	5.6	1.8	50							60	7.1				1.4	50			
	50	6.3	1.4	60							50	8.0				1.1	60			
	600	0.8	16.7	5					ECM035/030	120/240		600				1.0	13.1	5		ECM050/030
	400	1.2	13.0	7.5							400	1.5	10.2	7.5						
	300	1.5	10.6	10							300	1.9	8.3	10						
	200	2.2	7.3	15							200	2.8	5.7	15						
	150	2.8	4.9	20							150	3.6	3.9	20						
	120	3.4	4.4	25							120	4.3	3.5	25						
	100	3.9	4.6	30							100	4.9	3.6	30						
	75	4.9	3.3	40							75	6.2	2.6	40						
	60	5.7	2.6	50							60	7.2	2.1	50						
	50	6.5	2.1	60							50	8.3	1.7	60						
	38	8.0	1.5	80				38	10.2	1.2	80									
	30	9.1	1.2	100				30	11.6	0.9	100									

Dati tecnici ACM

AC

Technical data ACM

P_1 [W]	n_2 [min ⁻¹]	M_2 [Nm]	sf	i		Versione motore Motor version	P_1 [W]	n_2 [min ⁻¹]	M_2 [Nm]	sf	i		Versione motore Motor version							
40							60													
(1300 min ⁻¹)	260	1.3	10.2	5		ACM040/026	230/1 - 400/3	(1300 min ⁻¹)	260	1.9	6.8	5		ACM060/026	230/1 - 400/3					
	173	1.9	7.6	7.5							173	2.8				5.0	7.5			
	130	2.4	5.7	10							130	3.7				3.8	10			
	87	3.4	4.1	15							87	5.2				2.7	15			
	65	4.3	3.2	20							65	6.5				2.1	20			
	43	5.8	2.6	30							43	8.7				1.7	30			
	33	7.2	2.0	40							33	10.8				1.3	40			
	26	8.4	1.6	50							26	12.6				1.0	50			
	22	9.3	1.3	60							22	14.0				0.9	60			
	260	1.3	14.2	5					ACM040/030	230/1 - 400/3		260				1.9	6.9	5		ACM060/030
	173	1.9	10.7	7.5							173	2.8	5.3	7.5						
	130	2.5	8.5	10							130	3.7	4.3	10						
	87	3.5	6.0	15							87	5.2	3.1	15						
	65	4.4	4.3	20							65	6.6	2.1	20						
	52	5.3	3.8	25							52	7.9	1.9	25						
	43	5.9	3.7	30							43	8.9	2.0	30						
	33	7.3	2.7	40							33	10.9	1.5	40						
	26	8.5	2.2	50							26	12.8	1.2	50						
	22	9.7	1.8	60							22	14.5	1.0	60						
	16	11.3	1.3	80				16	16.9	0.7	80									
	13	12.6	1.1	100				13	16.0	0.7	100									



Dati tecnici calcolati secondo i valori di rendimento teorico dei riduttori dopo il rodaggio (vedi tabella)
Technical data calculated by using the theoretical efficiency of the gearboxes after the first running period (see table)

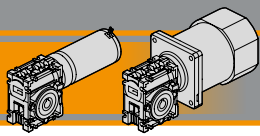

Dimensioni

DC

Dimensions

ECM035/026 U

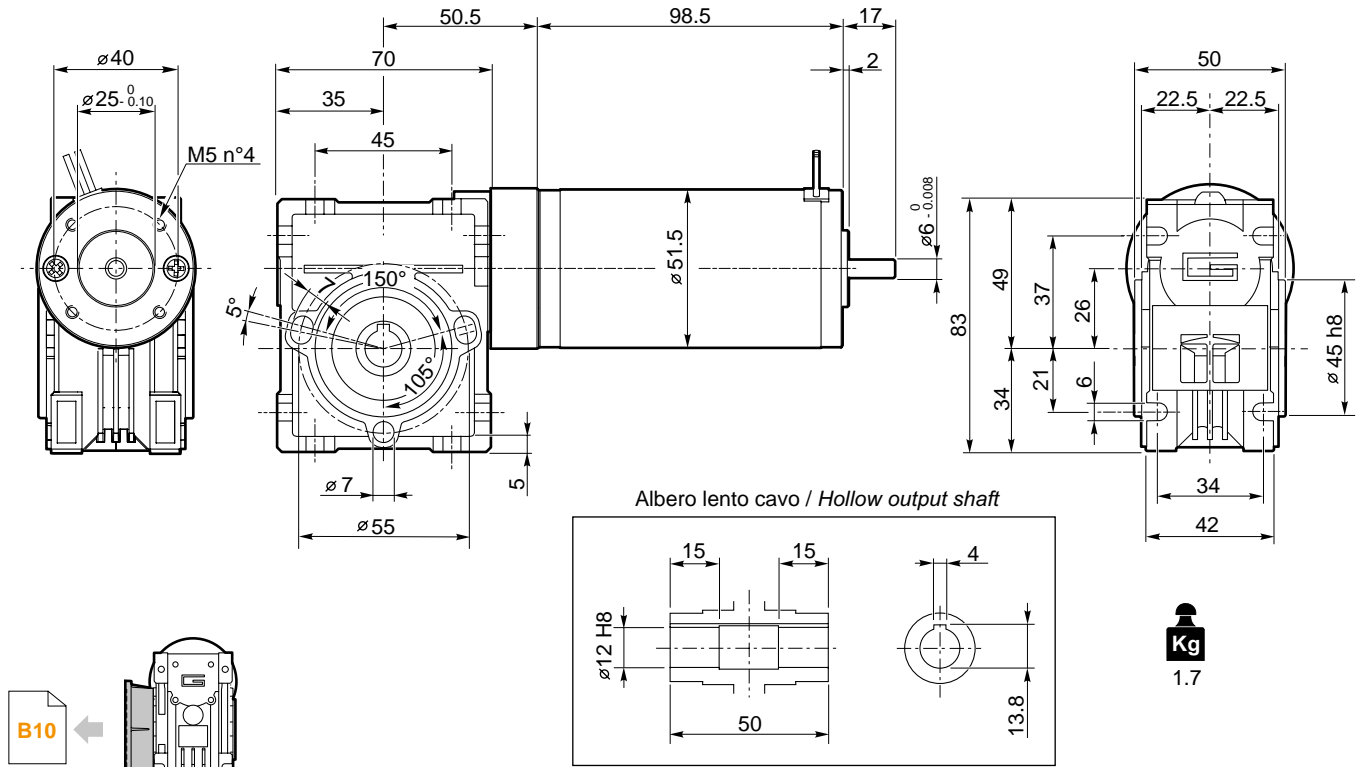

ECM035/026 F

ECM050/026 U

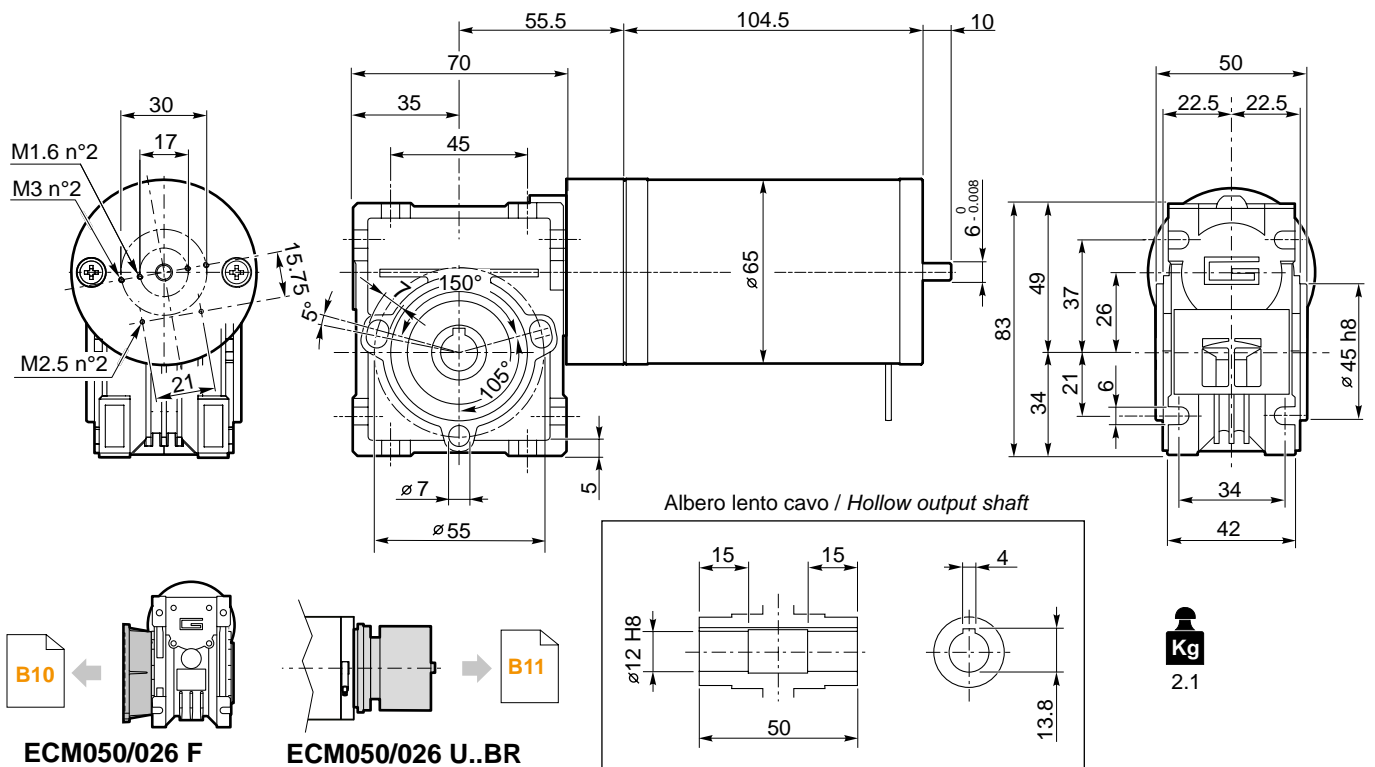

ECM050/026 F

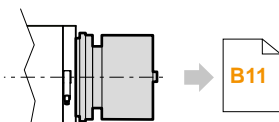

ECM050/026 U..BR
ECM050/026 U..BRL

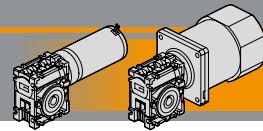

Dimensioni

DC

Dimensions

ECM035/030 U

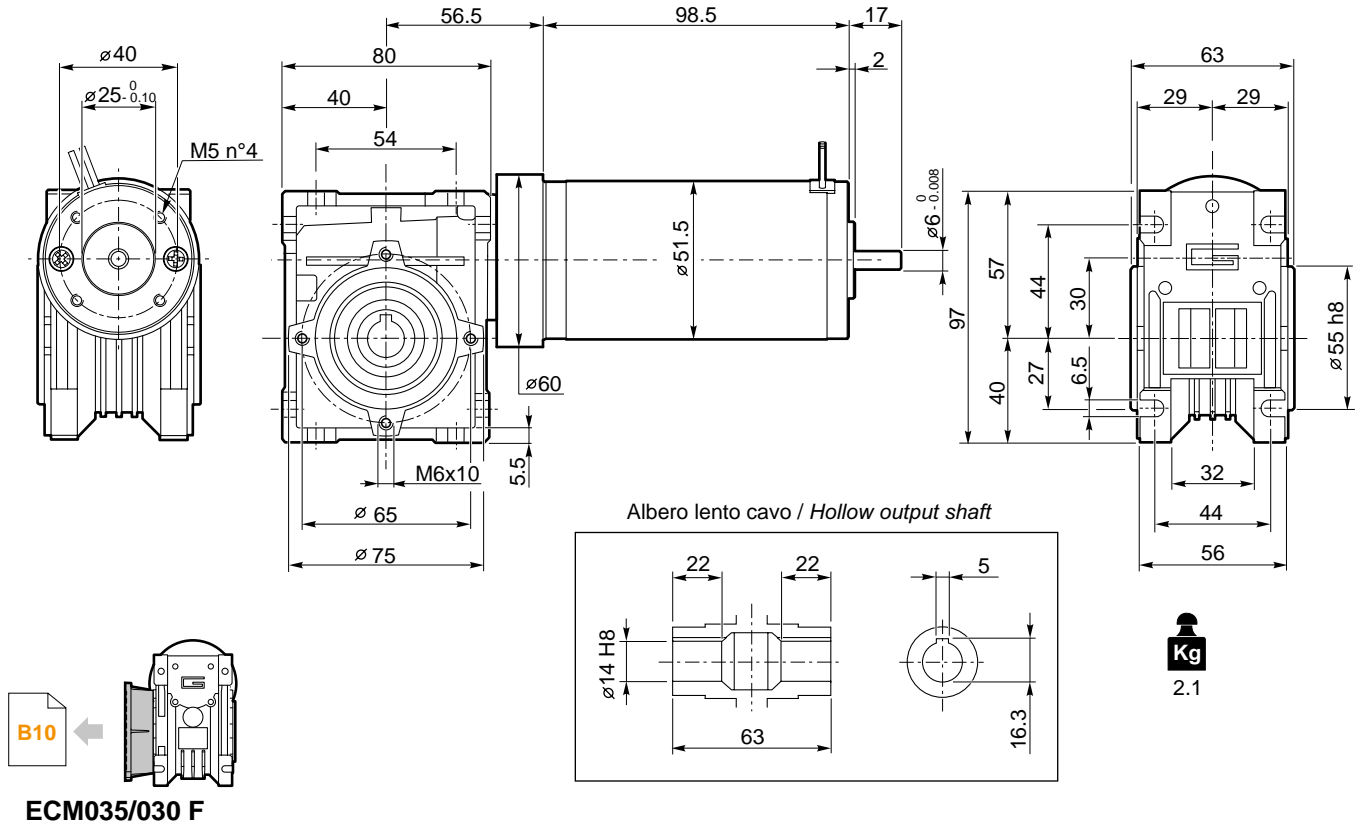

ECM050/030 U

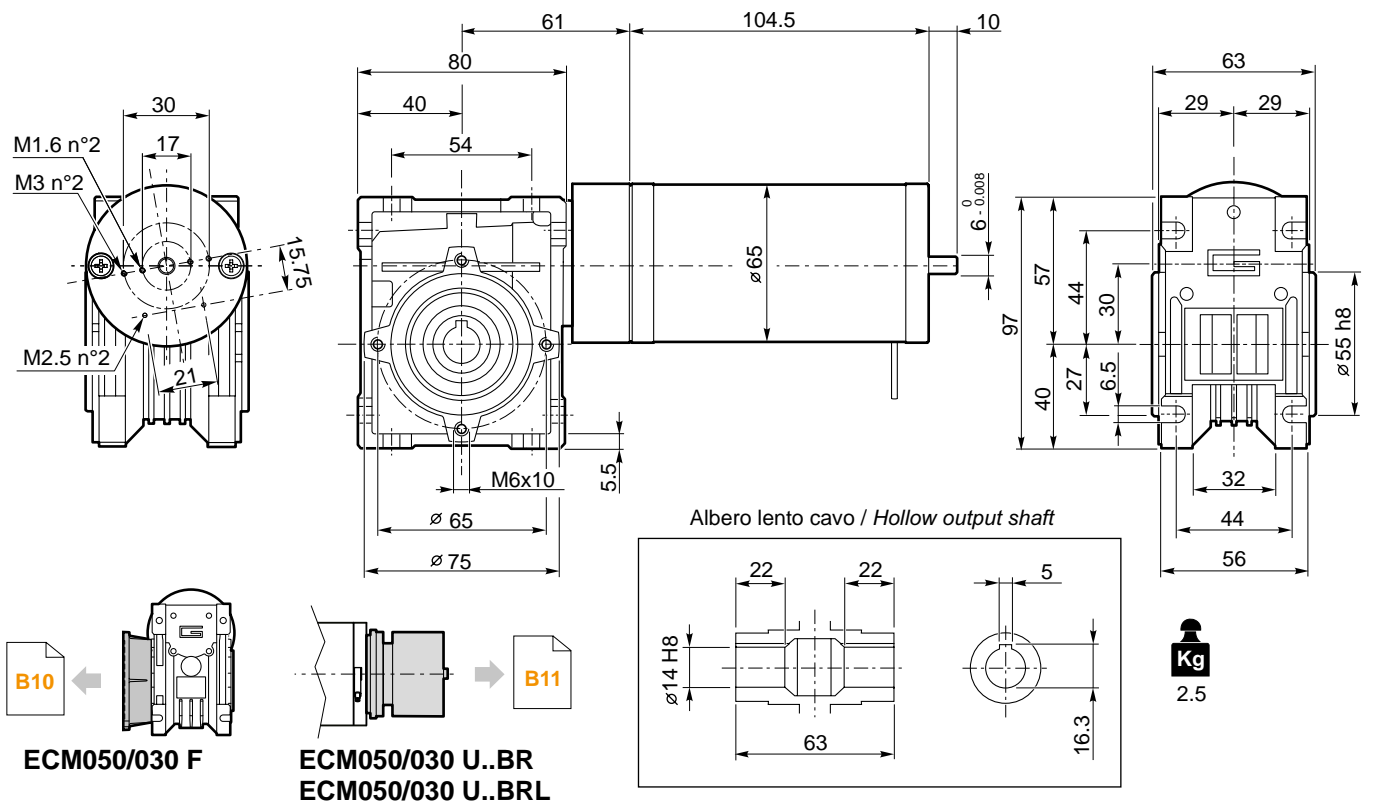

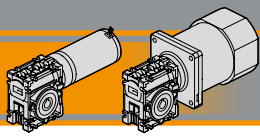

Dimensioni

AC

Dimensions

ACM040/026 U

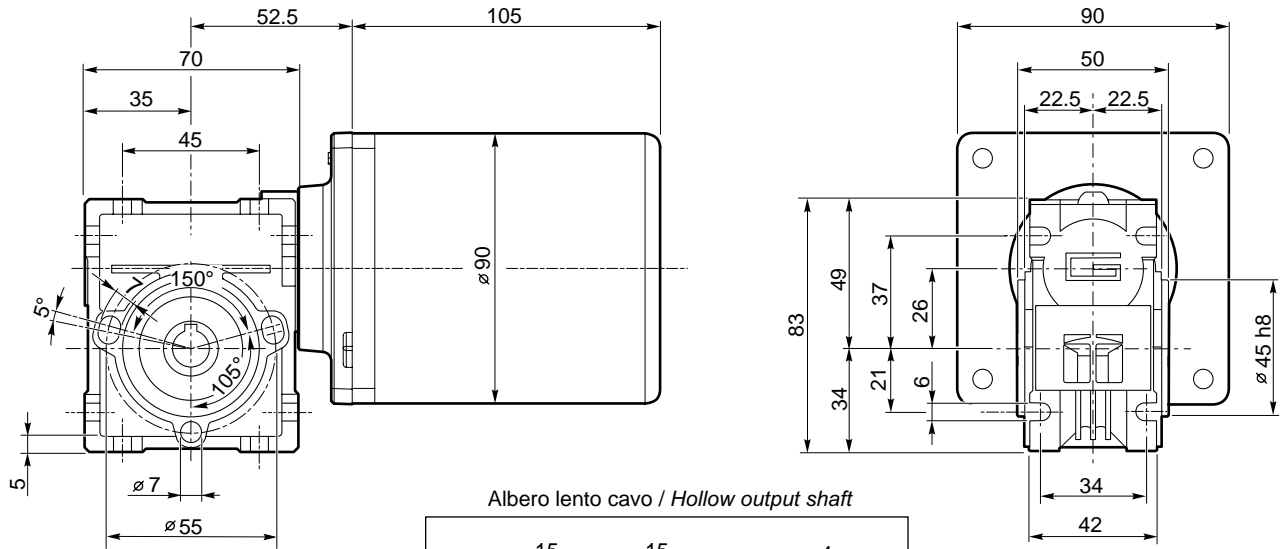

Albero lento cavo / Hollow output shaft

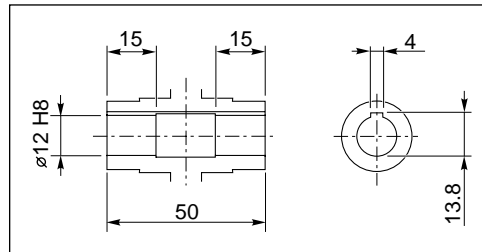

Kg
3.4

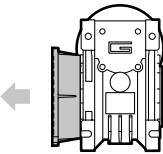

ACM040/026 F

ACM060/026 U

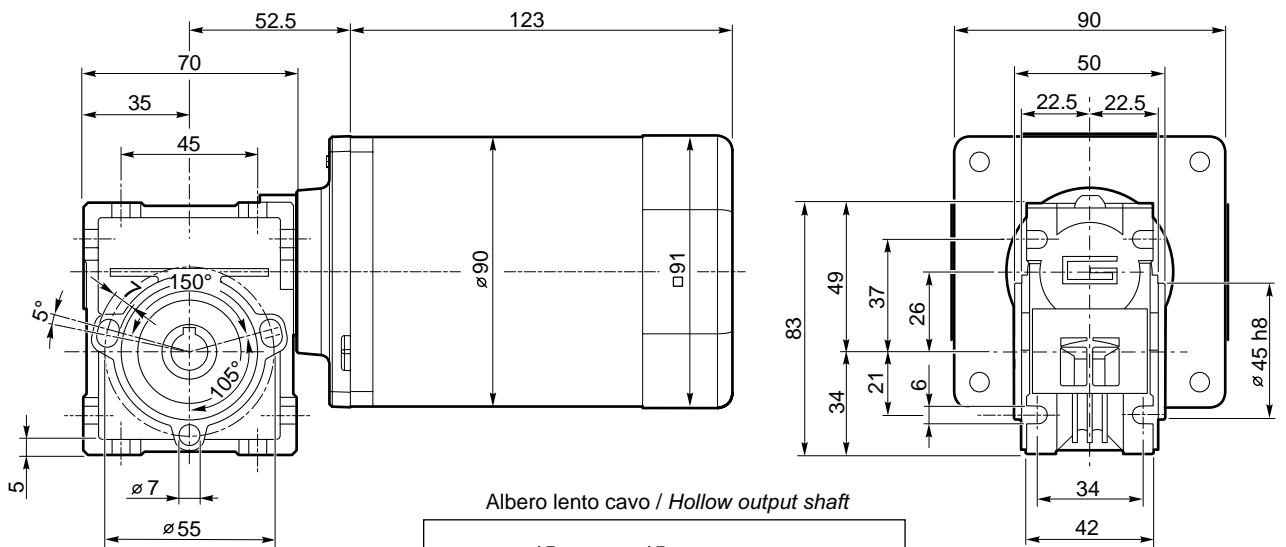

Albero lento cavo / Hollow output shaft

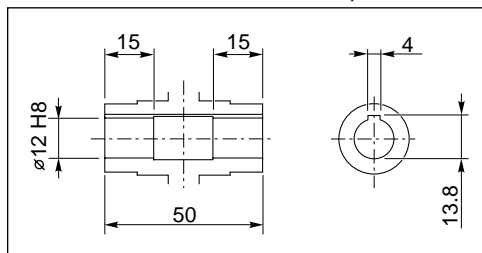

Kg
3.6

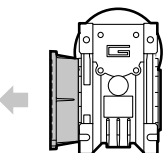

ACM060/026 F

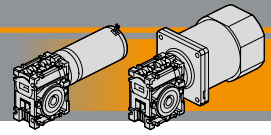

Dimensioni

AC

Dimensions

ACM040/030 U

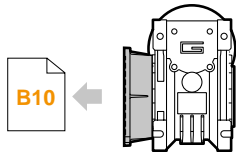
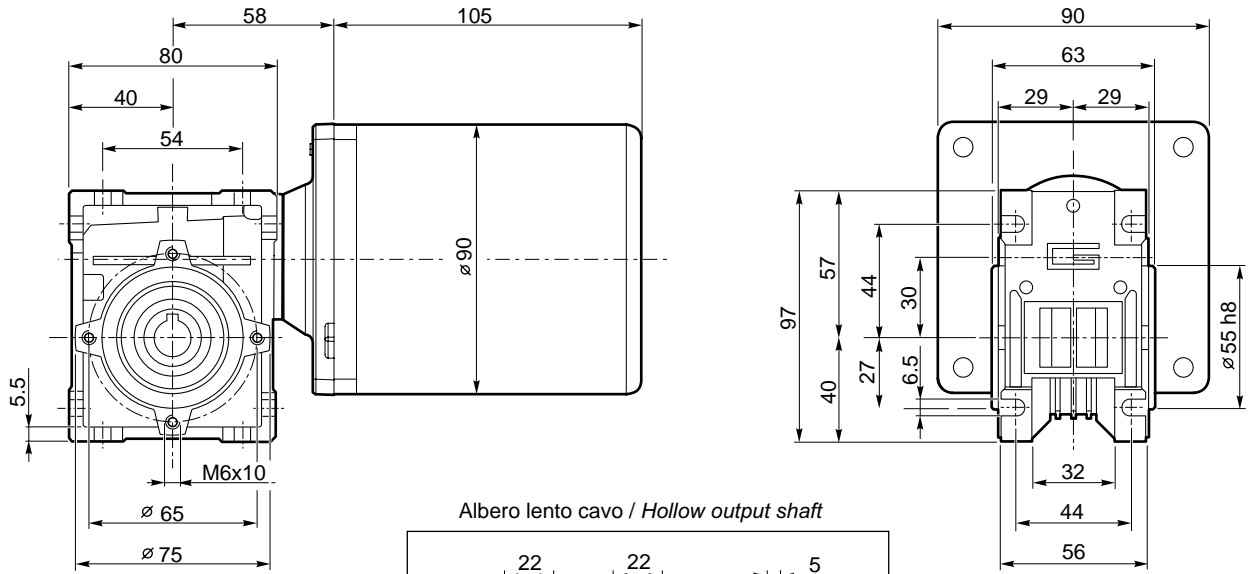

ACM040/030 F

Kg
3.8

ACM060/030 U

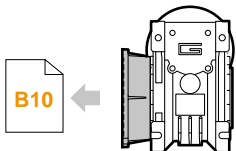
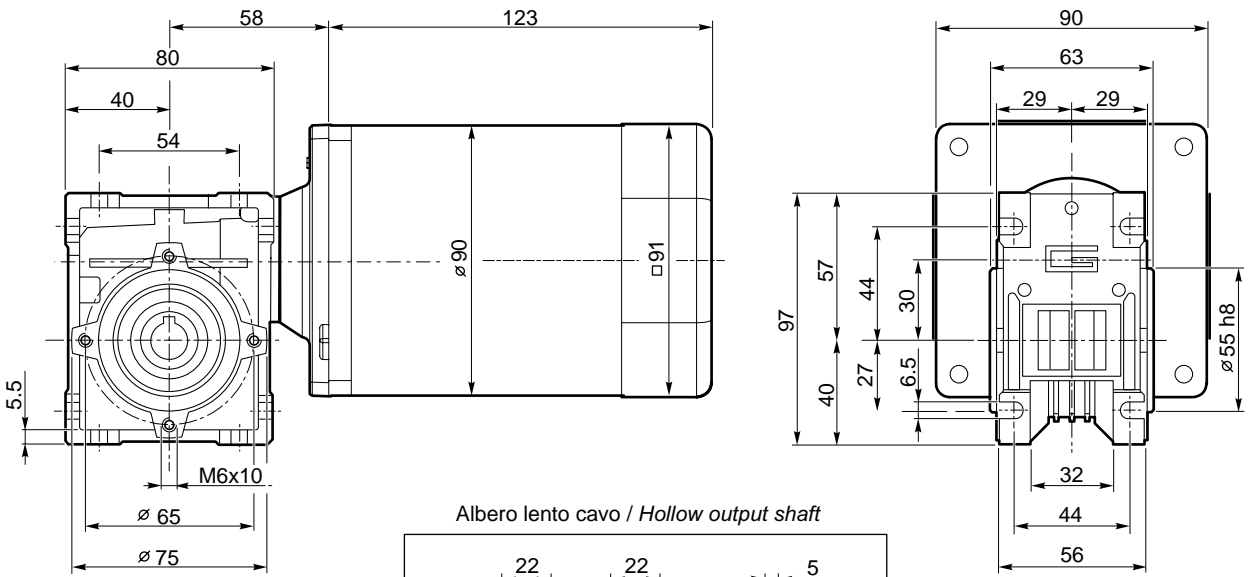

ACM060/030 F

Kg
4.0

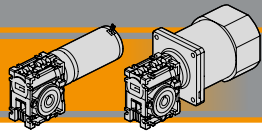

Dimensioni

Dimensions

ECM.../026 F... Flange uscita / Output flanges
ACM.../026 F...

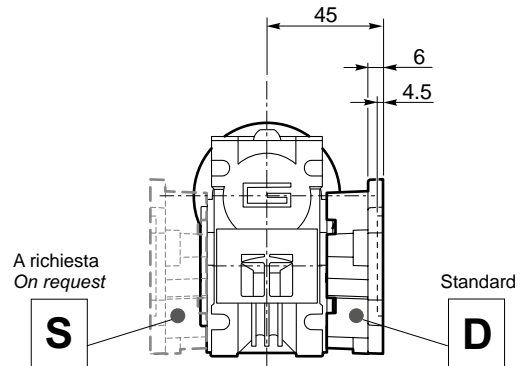
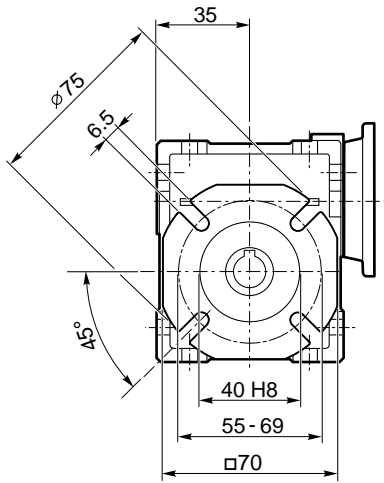

ECM.../030 F... Flange uscita / Output flanges
ACM.../030 F...

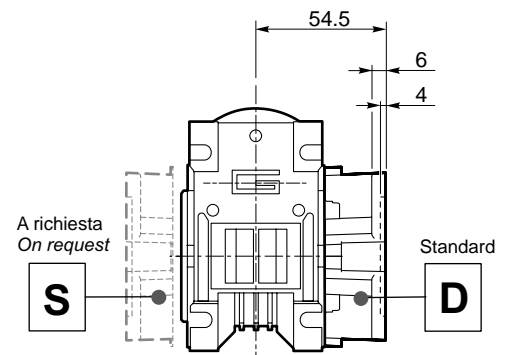
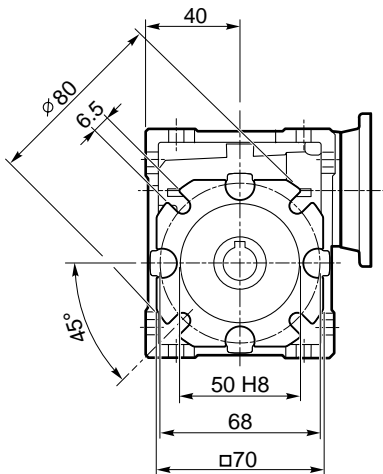

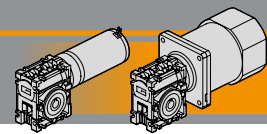

Accessori

Accessories

Albero lento semplice e doppio

Single and double Output shaft

026

SZ

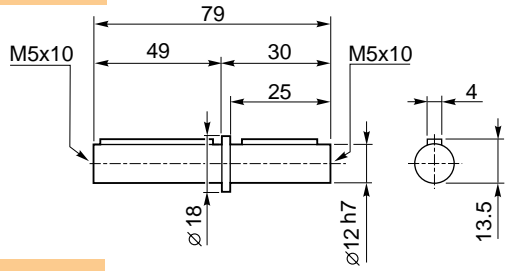

030

SZ

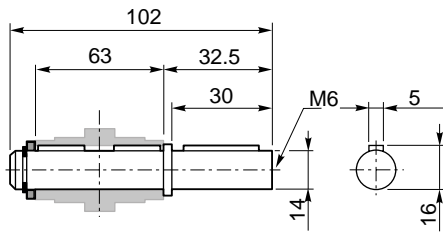

030

DZ

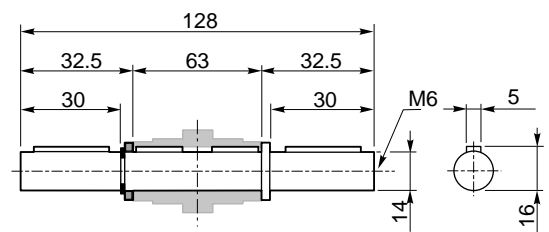

Braccio di reazione

Torque arm

030

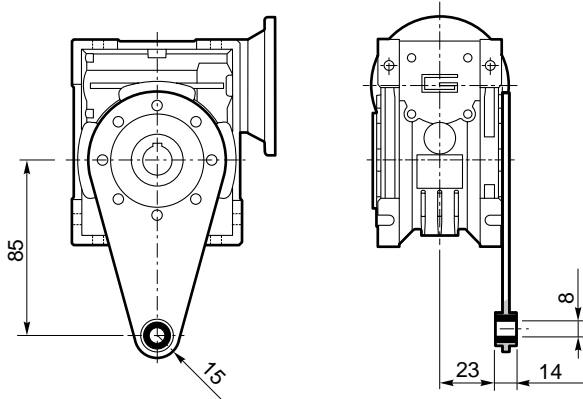

ECM ... U BR Freno / Brake

ECM ... U BRL Freno con leva di sblocco / Brake with hand release

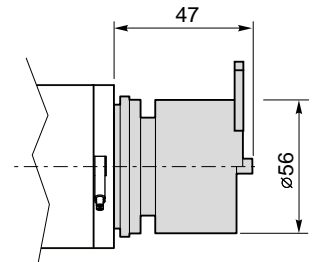
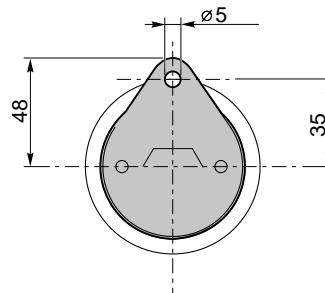
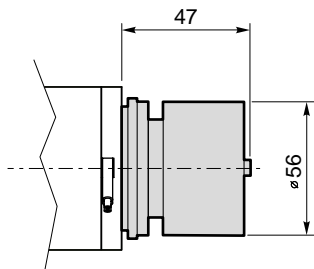



Riduttori epicicloidali Planetary gear units



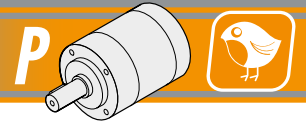

Indice	Index	Pag. Page
Caratteristiche tecniche	<i>Technical features</i>	C2
Designazione	<i>Classification</i>	C2
Versioni	<i>Versions</i>	C2
Simbologia	<i>Symbols</i>	C2
Lubrificazione	<i>Lubrication</i>	C3
Carichi radiali e assiali	<i>Radial and axial loads</i>	C3
Dati tecnici	<i>Technical data</i>	C4
Dimensioni	<i>Dimensions</i>	C5

Questa sezione annulla e sostituisce ogni precedente edizione o revisione. Qualora questa sezione non Vi sia giunta in distribuzione controllata, l'aggiornamento dei dati ivi contenuto non è assicurato. **In tal caso la versione più aggiornata è disponibile sul nostro sito internet www.transtecno.com**

*This section replaces any previous edition and revision. If you obtained this catalogue other than through controlled distribution channels, the most up to date content is not guaranteed. **In this case the latest version is available on our web site www.transtecno.com***

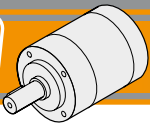
**P****RIDUTTORI EPICICLOIDALI**
PLANETARY GEAR UNITS**Caratteristiche tecniche****Technical features**

I riduttori epicicloidali della serie P hanno le seguenti caratteristiche principali:

P planetary gearboxes have the following features:

- Ingresso ed uscita coassiali
- Senso di rotazione concorde ingresso/uscita
- Alte coppie in ingombri ridotti
- Adatti per servizio continuo ed intermittente

- *Coaxial arrangement of the input and output*
- *Same rotation input/output*
- *Advantageous torque with minimum space requirements*
- *Suitable for continuous, reversing and intermittent operation*

Designazione**Classification**

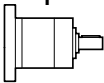
RIDUTTORE / GEARBOX					
P	52	2	C	34.97	AS60
Tipo Type	Grandezza Size	Stadi riduttore Gearbox stages	Versione riduttore Gearbox Version	Rapporto Ratio	Flangia ingresso Input flange
	42 52 62 72 81 105 120	1 2 3	U C80 C90 C105 C120 C140 C160	Vedere tabella See tables	Vedere tabella See tables

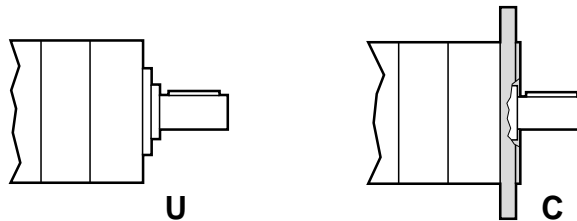
Versioni**Versions****Simbologia****Symbols**

N_s	Stadi / Stages	M_{n_2} [Nm]	Coppia nominale in uscita / Nominal output torque
n_1 [min ⁻¹]	Velocità in ingresso / Input speed	Rd %	Rendimento dinamico / Dynamic efficiency
n_2 [min ⁻¹]	Velocità in uscita / Output speed	A_2 [N]	Carico assiale ammissibile in uscita / Permitted output axial load
i	Rapporto di riduzione / Ratio	R_2 [N]	Carico radiale ammissibile in uscita / Permitted output radial load

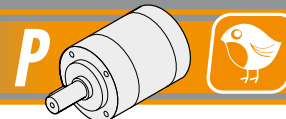
Lubrificazione
Lubrication

Tutti i riduttori P sono forniti completi di lubrificante, pertanto possono essere installati in qualunque posizione di montaggio e non necessitano di manutenzione.

Permanent grease long-life lubrication makes it possible to use P in all mounting positions.

Temperatura ambiente di funzionamento consentita / <i>Operating environmental temperature range</i>	-50 / +40 °C
---	--------------

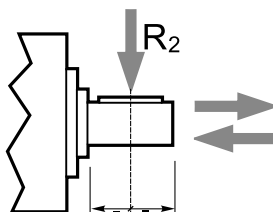
Carichi radiali e assiali
Radial and axial loads

$$n_1 = 3000 \text{ min}^{-1}$$

Grandezza Size	Albero uscita / <i>Output shaft</i>						Albero entrata / <i>Input shaft</i>	
	1 stadio / <i>stage</i>		2 stadi / <i>stages</i>		3 stadi / <i>stages</i>		1 - 2 - 3 stadi / <i>stages</i>	
	R_2 [N]	A_2 [N]	R_2 [N]	A_2 [N]	R_2 [N]	A_2 [N]	R_2 [N]	A_2 [N]
P42	160	50	230	80	300	110	70	40
P52	200	60	320	100	450	150	110	50
P62	240	70	360	100	520	150	120	60
P72	320	70	480	100	760	160	160	80
P81	400	80	600	120	1000	200	200	100
P105	600	120	900	180	1500	300	240	125
P120	600	120	900	180	1500	300	300	150

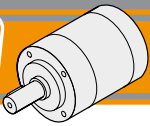
**P****RIDUTTORI EPICICLOIDALI**
PLANETARY GEAR UNITS**Dati tecnici****Technical data**

Ns	i	Mn ₂ [Nm]														
		P42		P52		P62		P72		P81		P105		P120		
		3000 rpm	1400 rpm	3000 rpm	1400 rpm	3000 rpm	1400 rpm	3000 rpm	1400 rpm	3000 rpm	1400 rpm	3000 rpm	1400 rpm	3000 rpm	1400 rpm	
1	3.70													50	64	
	4.28	3	3.9	4	5.1	8	10	14	18	20	25	35	45	—	—	
	5.18													—	—	
	6.75													50	64	
2	13.73													150	192	
	15.88													—	—	
	18.36													—	—	
	19.20													—	—	
	22.20	7.5	9.6	12	15	25	32	42	54	60	77	105	134	—	—	
	25.01													150	192	
	26.85													—	—	
	28.93														—	—
	34.97														—	—
	45.56														150	192
3	50.89													300	384	
	58.85													—	—	
	68.06													—	—	
	71.16													—	—	
	78.71													—	—	
	92.70													300	384	
	95.17													—	—	
	99.50													—	—	
	107.20													—	—	
	115.07	15	19	25	32	50	64	84	107	120	154	195	250	—	—	
	123.97													—	—	
	129.62													—	—	
	139.13													—	—	
	149.90													—	—	
	168.84													300	384	
181.24													—	—		
195.26													—	—		
236.09													—	—		
307.54														300	384	

Rapporti preferenziali / Preferred ratios

Disponibili 4 stadi con rapporti fino a 2076 / Available 4 stages with ratio up to 2076

Dimensioni

Dimensions

P42 U

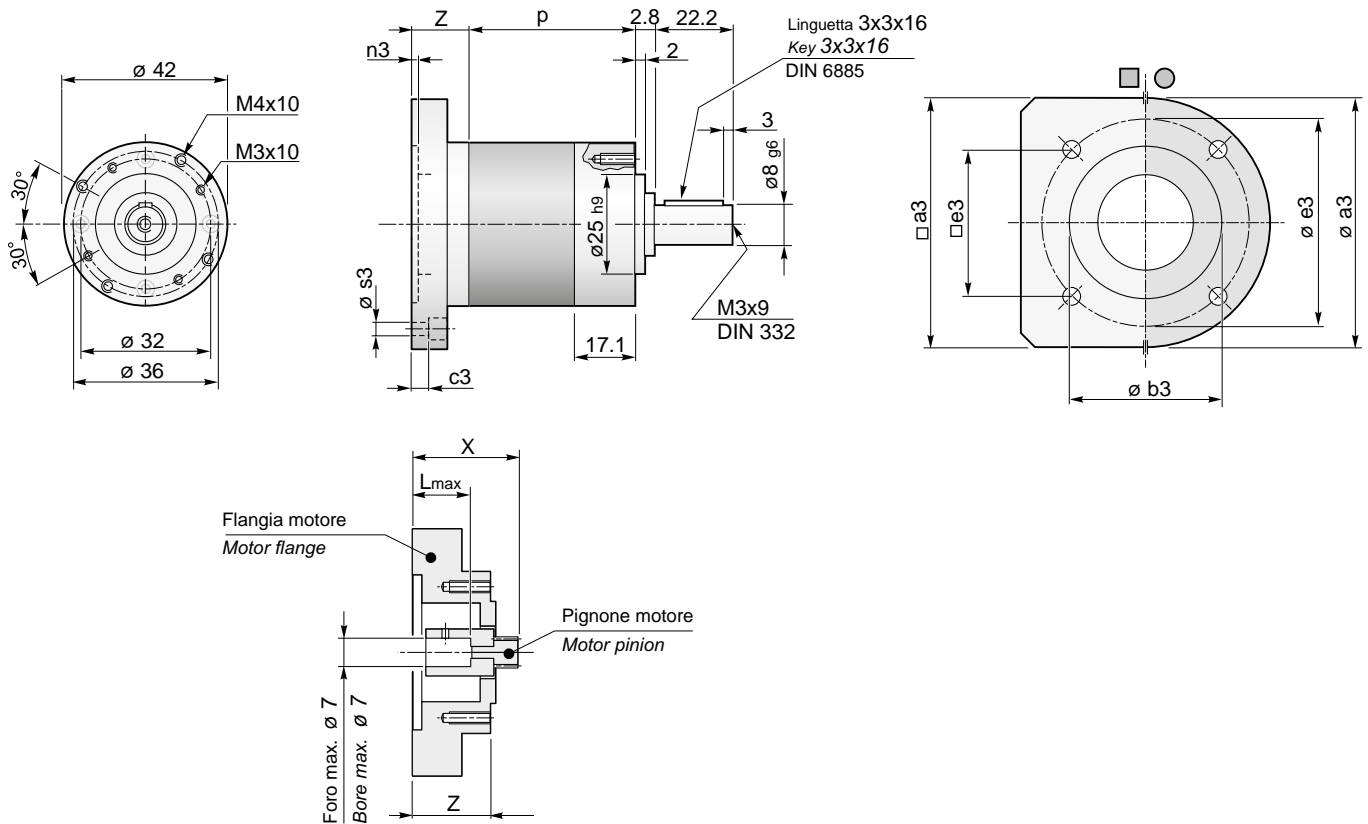

	Lunghezza riduttore Gearbox length		Peso Weight [kg]
	P		
P42...	1	39	0.4
	2	52	0.5
	3	65	0.6

	Flange entrata / Input flanges									
	Flangia Flange	a3	b3	c3	e3	n3	s3	Z	L max	X
P42	AS05	□ 42	22	17	□ 31	3	4 - Ø 3.5	32	25	42.7
	AS11	□ 56	38.1	/	□ 47.14	3	4 - M4	27	21	37.5
	AS32	Ø 42	22	13	Ø 32	3	4 - Ø 3.5	21	15	31.5
	AS33	Ø 42	16	16	Ø 25.5	3	4 - Ø 3.5	21	15	31.5
	AS47	Ø 64	28	5	Ø 50	3	3 - Ø 4.5	26.5	25	37
	AS58	□ 52	36	/	□ 41	2	4 - M4	27	21	37.5
	AS63	Ø 44	16	24	Ø 22	2	6 - Ø 3.3	31	25	39
	AS70	Ø 80	50	8.2	Ø 65	3	4 - Ø 5.5	26	20	36.5
	AS117	□ 56	22	3	Ø 40	3	4 - Ø 5.5	19	13	29.7
				/	□ 47		4 - M4			
	AS130	Ø 52	25	15	Ø 40	3	4 - Ø 5.5	21	15	31.5
	AS134	Ø 77	50	8.2	Ø 65	3	4 - Ø 5.5	21	15	31.5
				/	Ø 65		4 - M5			
AS213	□ 60	36	/	□ 50	2.5	4 - M4	28.9	23	39.4	

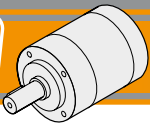

P

**RIDUTTORI EPICICLOIDALI
PLANETARY GEAR UNITS**

Dimensioni

Dimensions

P52 U

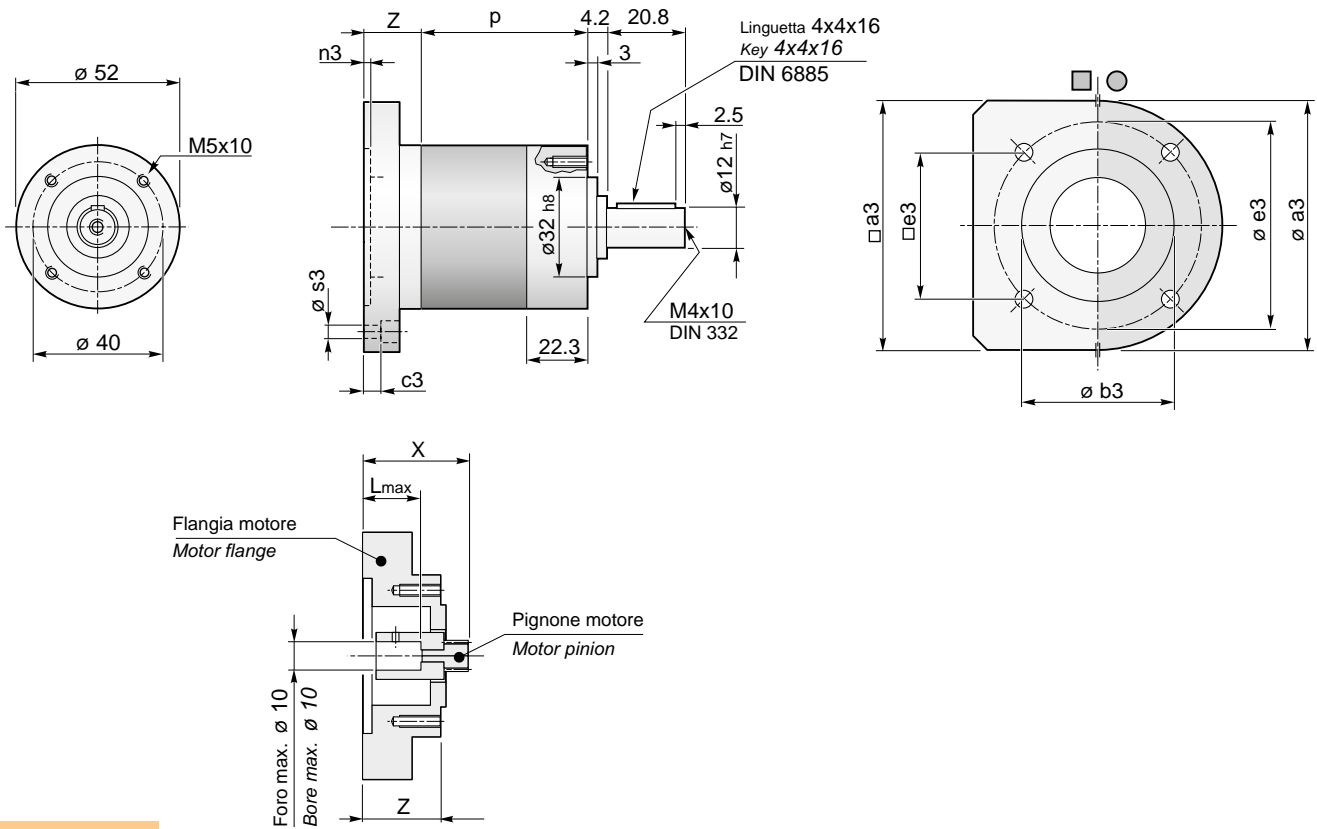

P52 C..

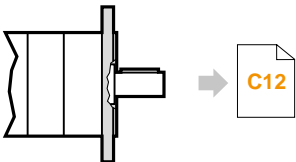

	Lunghezza riduttore Gearbox length		Peso Weight [kg]
	P		
P52...	1	46	0.7
	2	60	0.9
	3	74	1.1

P52	Flange entrata / Input flanges										
	Flangia Flange	IEC	a3	b3	c3	e3	n3	s3	Z	L max	X
	AS09	\	□ 60	36	/	□ 50	2	4 - M4	27	20.6	37.5
	AS23	\	Ø 60	26	17.5	Ø 39	3	4 - Ø 5.5	26.5	20	37
	AS36	\	Ø 60	28	15	Ø 42	3	4 - Ø 5.5	21	15	31.5
	AS38	\	Ø 65	32	18	Ø 46	3	4 - Ø 4.5	29	22.5	39.5
	AS50	\	Ø 79	45	14.5	Ø 65.5	3.5	4 - Ø 5.5	32	24	42.5
	AS51	\	Ø 68	28	21.5	Ø 50	3	3 - Ø 4.5	31.5	24	42
	AS60	56B14	Ø 80	50	10.2	Ø 65	3	4 - Ø 5.5	28	20	38.5
	AS68	\	Ø 52	22	13	Ø 30	3	4 - Ø 4.5	28	20	38.5
	AS86	\	Ø 52	30	/	Ø 46	3	4 - M4	33.5	25	44
	AS109	\	Ø 80	55	10	Ø 65	3	4 - Ø 6.5	24	16	34.5
	AS115	\	Ø 52	25	17.5	Ø 40	3	4 - Ø 5.5	26.5	20	37
	AS140	\	Ø 80	50	10.2	Ø 65	3	4 - Ø 5.5	28	20	38.5

Dimensioni

Dimensions

P62 U

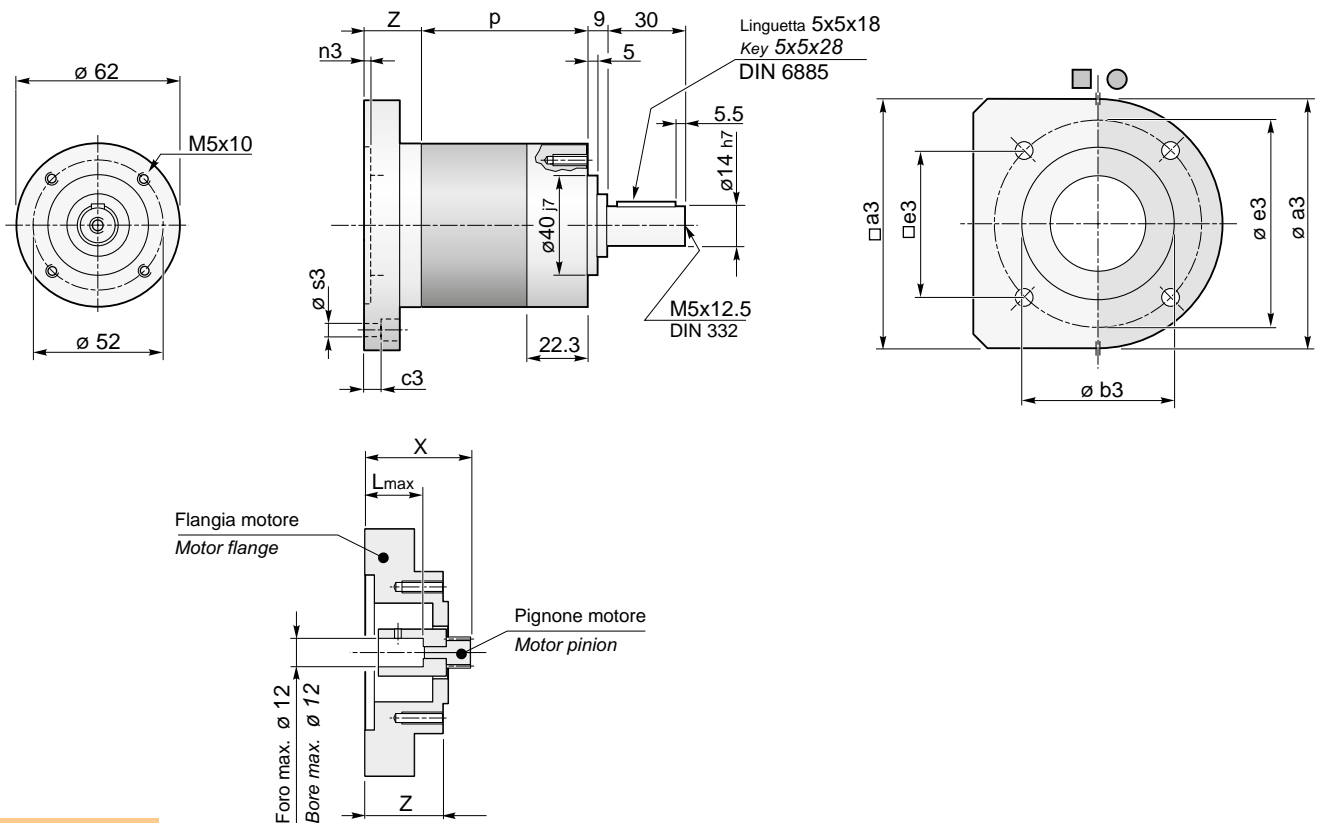

P62 C..

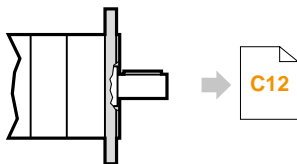

		Lunghezza riduttore Gearbox length	Peso Weight [kg]
		P	
P62...	1	46	0.8
	2	62	1.2
	3	78	1.6

P62	Flange entrata / Input flanges										
	Flangia Flange	IEC	a3	b3	c3	e3	n3	s3	Z	L max	X
	AS08	\	□ 60	50	/	□ 49.5	4	4 - M4	37	30	49.8
	AS12	\	□ 84.5	73.02	/	□ 69.6	2	4 - M5	40	30	52.8
	AS15	\	□ 58	38.1	/	□ 47.14	2	4 - M4	30	20.6	42.8
	AS61	63B14	∅ 90	60	7	∅ 75	3	4 - ∅ 5.5	30	23	42.8
	AS244	56B14	∅ 80	50	5	∅ 65	3.5	4 - ∅ 5.5	28	20	40.8

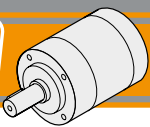

P

**RIDUTTORI EPICICLOIDALI
PLANETARY GEAR UNITS**

Dimensioni

Dimensions

P72 U

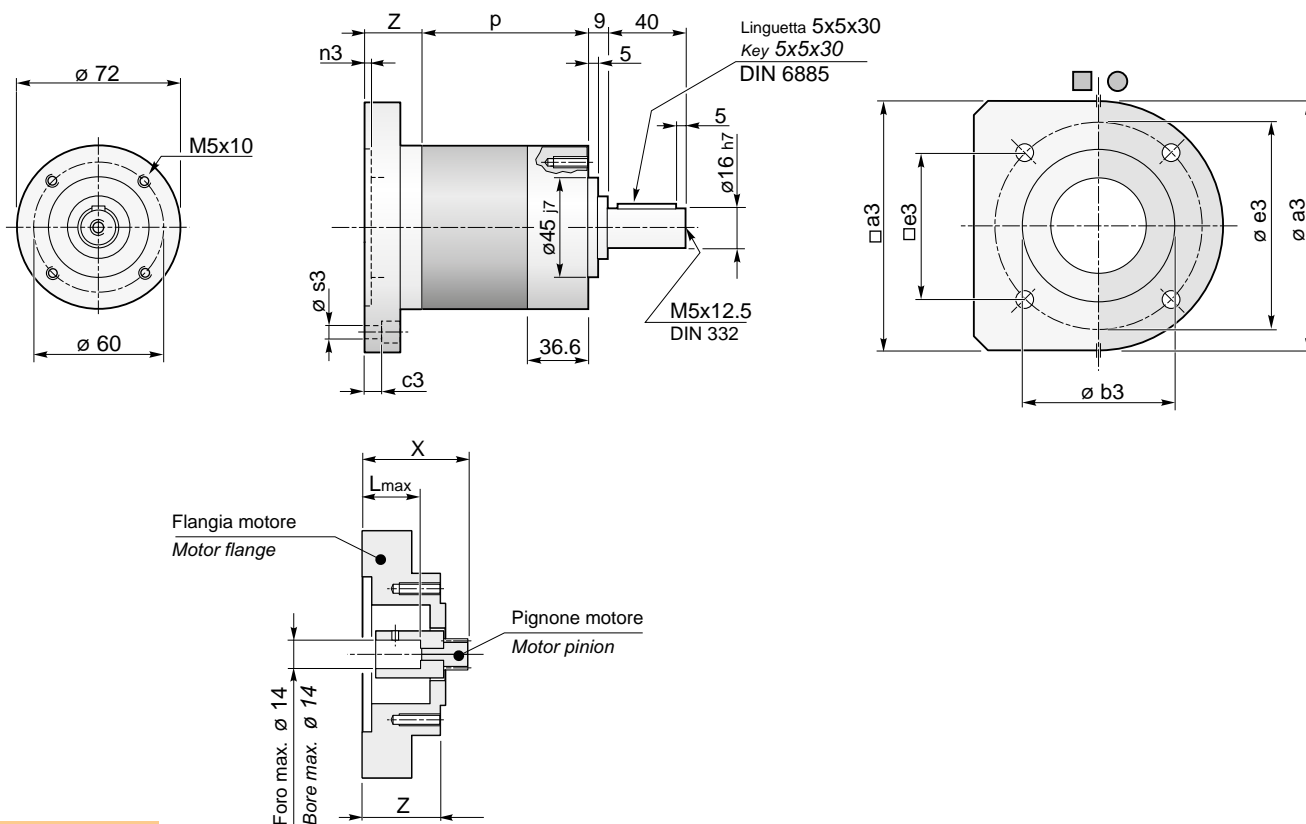

P72 C..

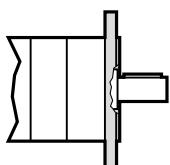

		Lunghezza riduttore Gearbox length	Peso Weight [kg]
		P	
P72...	1	56.9	1.4
	2	76.5	1.9
	3	96.1	2.4

P72	Flange entrata / Input flanges										
	Flangia Flange	IEC	a3	b3	c3	e3	n3	s3	Z	L max	X
	AS245	56B14	Ø 80	50	5	Ø 65	4.5	4 - Ø 5.5	28.5	20	38.9
	AS246	63B14	Ø 90	60	5	Ø 75	3.5	4 - Ø 5.5	31.5	23	41.9
	AS247	71B14	Ø 105	70	6	Ø 85	4	4 - Ø 6.5	38.5	30	48.9

Dimensioni

Dimensions

P81 U

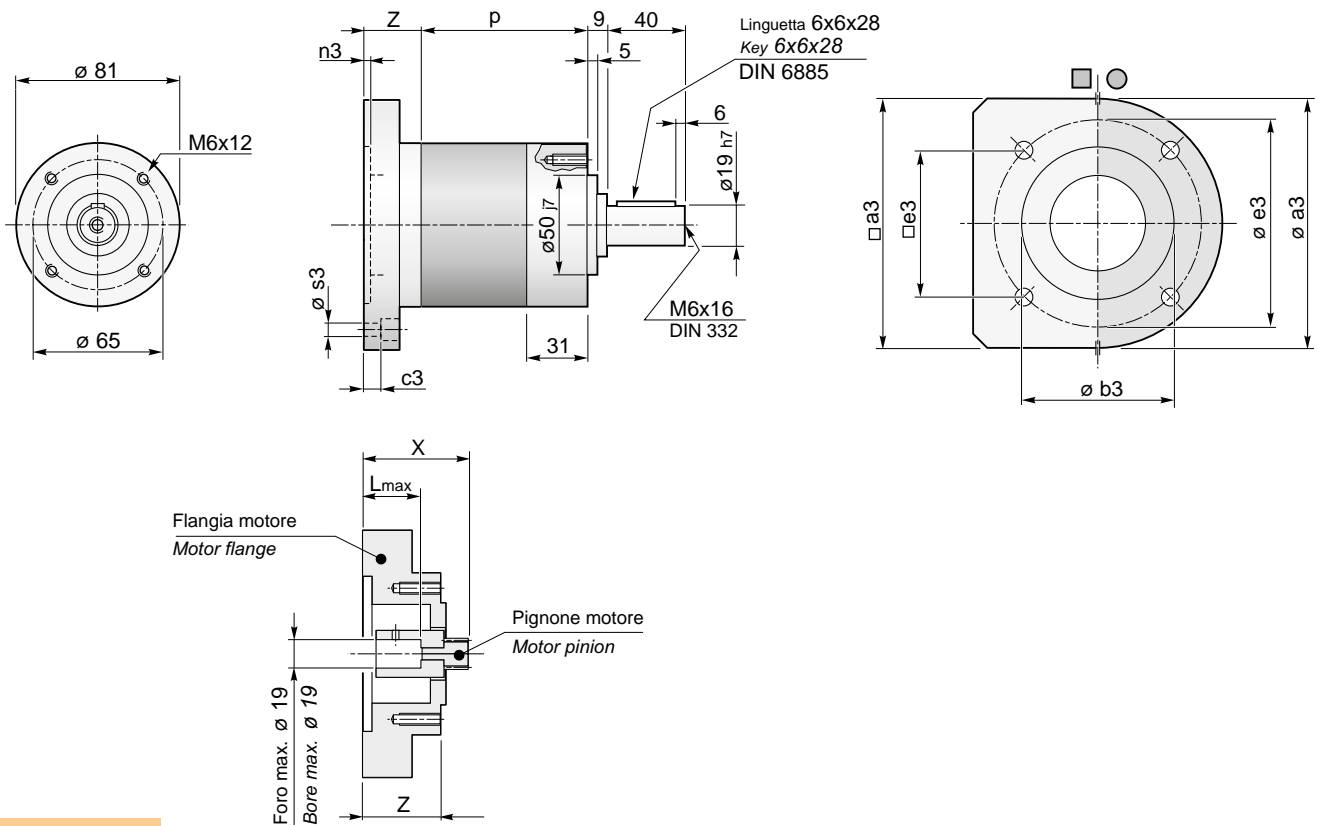

P81 C..

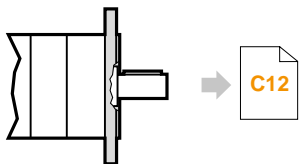

		Lunghezza riduttore Gearbox length	Peso Weight [kg]
		P	
P81...	1	59	1.8
	2	81	2.5
	3	103	3.2

P81	Flange entrata / Input flanges										
	Flangia Flange	IEC	a3	b3	c3	e3	n3	s3	Z	L max	X
	AS04	\	□ 100	95	25	∅ 115	3.5	4 - ∅ 9	43	30	59.3
	AS12B	\	□ 85	73.02	—	□ 69.6	2	4 - M5	43	30	59.3
	AS18	\	∅ 114	80	26	∅ 100	4	4 - ∅ 6.5	53	40	69.3
	AS30	\	∅ 80	50	35.5	∅ 70	3.5	4 - ∅ 5.5	42.5	28	58.8
	AS40	\	□ 80	70	26.5	∅ 90	4	4 - ∅ 6.5	52.5	40	68.8
	AS73	\	□ 110	55.524	49.8	□ 88.9	2	4 - ∅ 8.5	67.8	55.63	84.1
	AS92	\	□ 85	35	—	□ 69.6	10.5	4 - M5	53	40.2	69.3
	AS248	56B14	∅ 80	50	5	∅ 65	3.5	4 - ∅ 5.5	35	20	48.3
	AS249	63B14	∅ 90	60	5	∅ 75	3.5	4 - ∅ 5.5	35	23	51.3
	AS254	71B14	∅ 105	70	6	∅ 85	4	4 - ∅ 6.5	42	30	58.3
	AS280	80B14	∅ 120	80	10	∅ 100	4	4 - ∅ 6.5	52	40	68.3

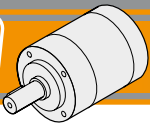

P

RIDUTTORI EPICICLOIDALI
PLANETARY GEAR UNITS

Dimensioni

Dimensions

P105 U

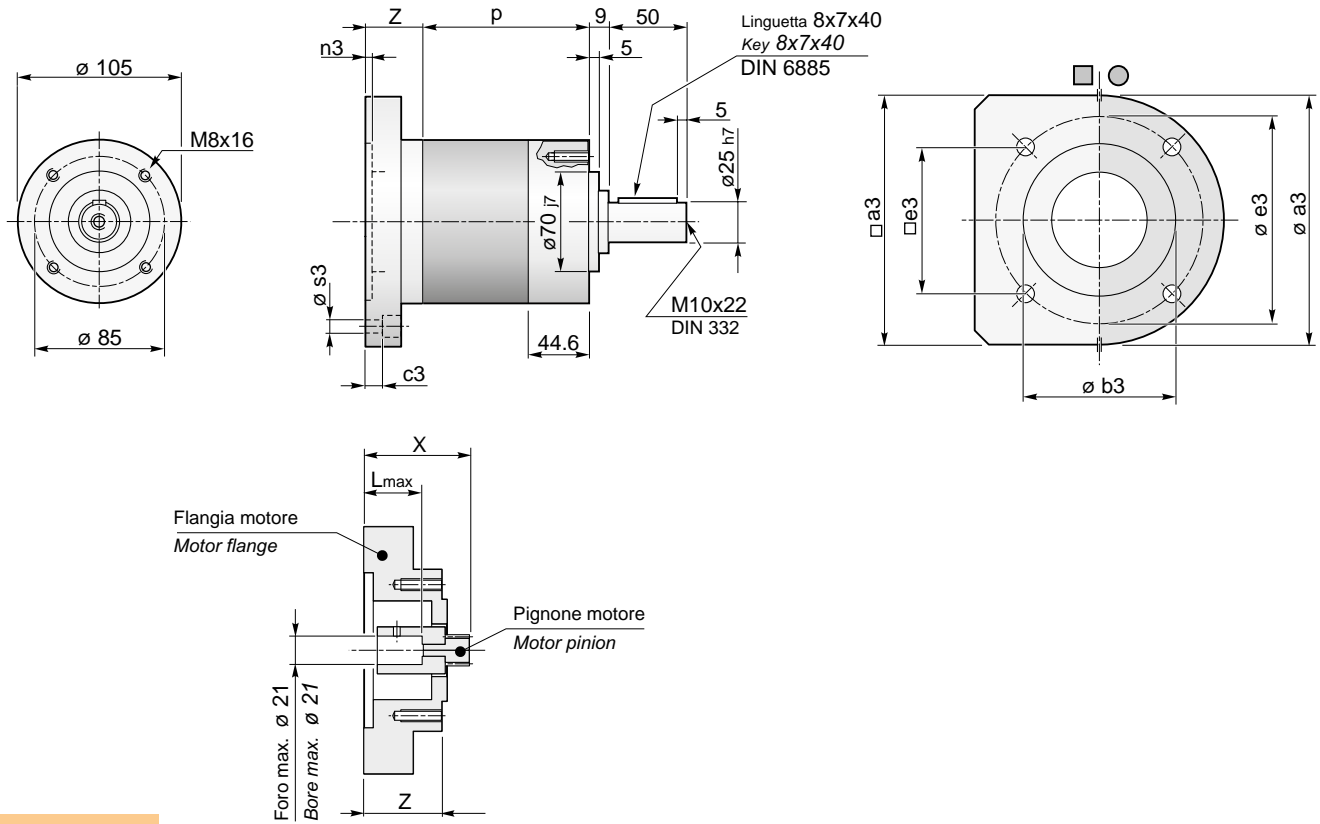

P105 C..

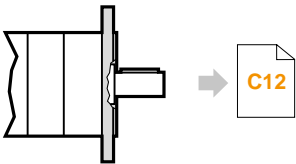

		Lunghezza riduttore Gearbox length	Peso Weight [kg]
		P	
P105...	1	76.4	4.4
	2	107.5	6.0
	3	138.5	7.6

P105	Flange entrata / Input flanges										
	Flangia Flange	IEC	a3	b3	c3	e3	n3	s3	Z	L max	X
	AS250	56B14	Ø 105	50	5	Ø 65	3.5	4 - Ø 5.5	40	20	52.3
	AS251	63B14	Ø 105	60	5	Ø 75	3.5	4 - Ø 5.5	40	23	55.3
	AS252	71B14	Ø 105	70	6	Ø 85	4	4 - Ø 6.5	47	30	62.3
AS281	80B14	Ø 120	80	8	Ø 100	4	4 - Ø 6.5	57.5	40	72.3	

Dimensioni

Dimensions

P120 U

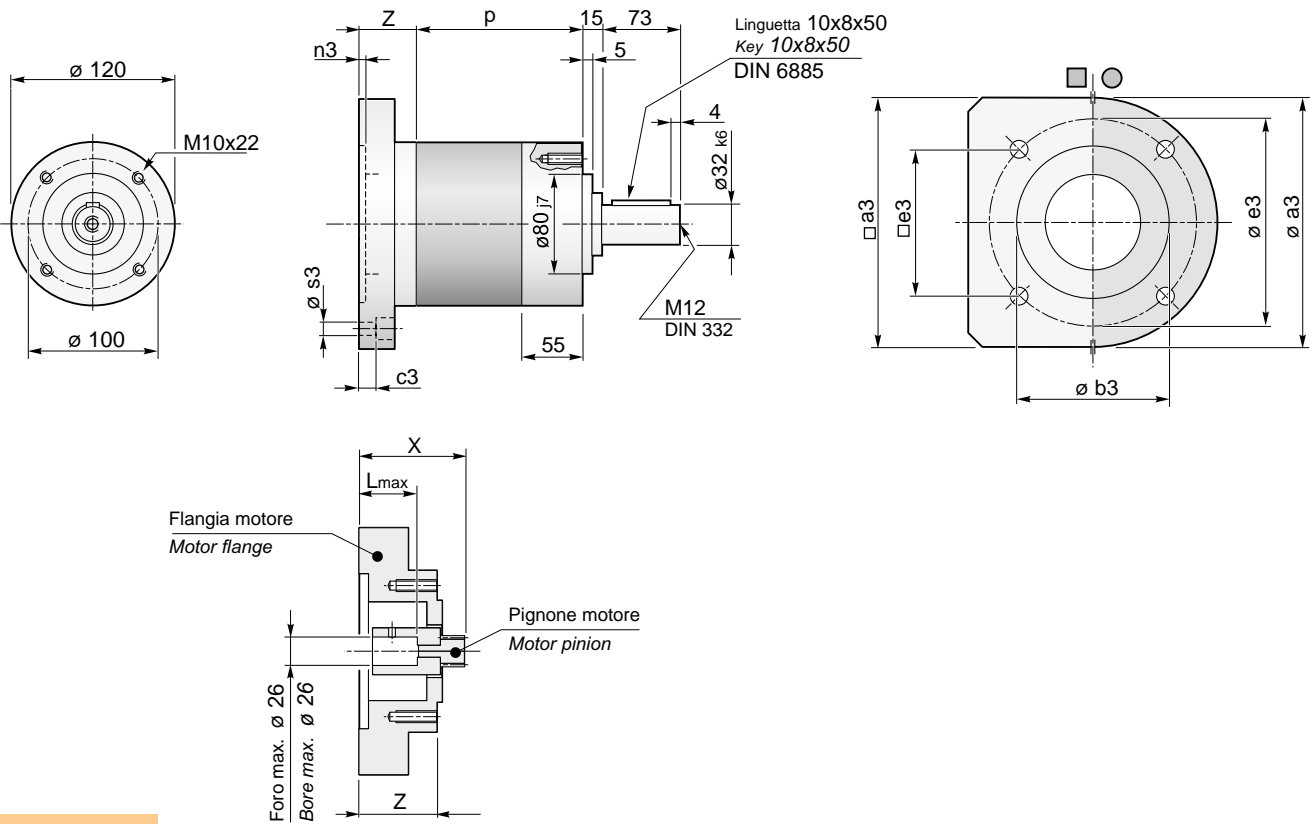

P120 C..

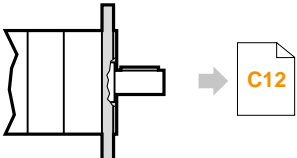

		Lunghezza riduttore Gearbox length	Peso Weight [kg]
		P	
P120...	1	89.7	5.6
	2	123.9	8.0
	3	158.1	10.4

P120	Flange entrata / Input flanges										
	Flangia Flange	IEC	a3	b3	c3	e3	n3	s3	Z	L max	X
	AS255	56B14	Ø 120	50	5	Ø 65	3.5	4 - Ø 5.5	44.7	20	60.2
	AS256	63B14	Ø 120	60	5	Ø 75	3.5	4 - Ø 5.5	44.7	23	63.2
	AS257	71B14	Ø 120	70	6	Ø 85	4	4 - Ø 6.5	46.8	30	70.2
	AS282	80B14	Ø 120	80	8	Ø 100	4	4 - Ø 6.5	56.8	40	80.2
	AS283	90B14	Ø 140	95	10	Ø 115	4.5	4 - Ø 8.5	66.8	50	90.2

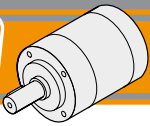
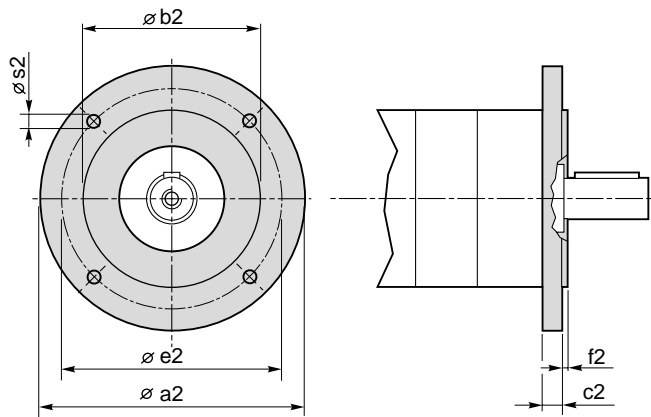
**P****RIDUTTORI EPICICLOIDALI**
PLANETARY GEAR UNITS**Dimensioni****Dimensions****P.. C..****Flange uscita / Output flanges**

P	Flange uscita / Output flanges						Flangia Flange
	a2	b2	c2	e2	f2	s2	
52	80	50 j7	9	65	2.5	M5	C80
	90	60 j7	9	75	2.5	5.5	C90
	105	70 j7	9	85	2.5	6.5	C105
	120	80 j7	9	100	3.0	6.5	C120
62	80	50 j7	9	65	2.5	M5	C80
	90	60 j7	9	75	2.5	5.5	C90
	105	70 j7	9	85	2.5	6.5	C105
	120	80 j7	9	100	3.0	6.5	C120
72	80	50 j7	9	65	2.5	M5	C80
	90	60 j7	9	75	2.5	M5	C90
	105	70 j7	9	85	2.5	6.5	C105
	120	80 j7	9	100	3.0	6.5	C120
81	90	60 j7	9	75	2.5	M5	C90
	105	70 j7	9	85	2.5	M6	C105
	120	80 j7	9	100	3.0	6.5	C120
105	120	80 j7	12	100	3	M6	C120
	140	95 j7	12	115	3.5	M8	C140
	160	110 j7	12	130	3.5	M8	C160
120	140	95 j7	15	115	3	M8	C140
	160	110 j7	15	130	3.5	M8	C160

TRANSTECNO[®]
the modular gearmotor

ACP



Small but Strong

ACP

Motoriduttori CA epicicloidali AC planetary gearmotors





Indice	Index	Pag. Page
Caratteristiche tecniche	<i>Technical features</i>	D2
Designazione	<i>Classification</i>	D2
Versioni	<i>Versions</i>	D2
Simbologia	<i>Symbols</i>	D2
Lubrificazione	<i>Lubrication</i>	D3
Carichi radiali	<i>Radial loads</i>	D3
Rapporti	<i>Ratios</i>	D4
Dati tecnici	<i>Technical data</i>	D5
Motori applicabili	<i>IEC Motor adapters</i>	D12
Dimensioni	<i>Dimensions</i>	D13

Questa sezione annulla e sostituisce ogni precedente edizione o revisione. Qualora questa sezione non Vi sia giunta in distribuzione controllata, l'aggiornamento dei dati ivi contenuto non è assicurato. **In tal caso la versione più aggiornata è disponibile sul nostro sito internet www.transtecno.com**

This section replaces any previous edition and revision. If you obtained this catalogue other than through controlled distribution channels, the most up to date content is not guaranteed. In this case the latest version is available on our web site www.transtecno.com

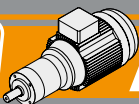

Caratteristiche tecniche

Technical features

Le caratteristiche principali dei motoriduttori epicicloidali della serie ACP sono:

The main features of ACP planetary gearmotors range are:

- Alimentazione in corrente alternata trifase;
 - Ingresso ed uscita coassiali;
 - Design compatto;
 - Lubrificazione permanente a grasso;
 - Possono essere installati in qualunque posizione di montaggio
- Threephase power supply;
 - Coaxial arrangement of the input and output;
 - Compact design;
 - Permanent grease long life lubrication;
 - Can be installed in all mounting positions.

Designazione

Classification

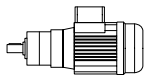
MOTORIDUTTORE / GEARMOTOR								
ACP	712/81					2	C	34.97
Tipo Type	Grandezza Size					Stadi riduttore Gearbox stages	Versione riduttore Gearbox Version	Rapporto Ratio
	56.../52	63.../62	71.../72	80.../81	90.../120	1	U	Vedere tabella See tables
	56.../62	63.../72	71.../81	80.../105		2	C80	
	56.../72	63.../81	71.../105	80.../120		3	C90	
	56.../81	63.../105	71.../120				C105	
	56.../105	63.../120					C120	
	56.../120						C140	
							C160	

Versioni

Versions

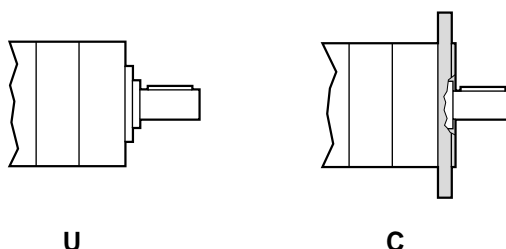

Simbologia

Symbols

n_1	[min ⁻¹]	Velocità in ingresso / <i>Input speed</i>	sf	Fattore di servizio / <i>Service factor</i>
n_2	[min ⁻¹]	Velocità in uscita / <i>Output speed</i>	Rd	% Rendimento dinamico / <i>Dynamic efficiency</i>
i		Rapporto di riduzione / <i>Ratio</i>	A_2	[N] Carico assiale ammissibile in uscita / <i>Permitted output axial load</i>
P_1	[kW]	Potenza in entrata / <i>Input power</i>	R_2	[N] Carico radiale ammissibile in uscita / <i>Permitted output radial load</i>
M_2	[Nm]	Coppia in uscita in funzione di P_1 / <i>Output torque referred to P_1</i>		

Lubrificazione

Lubrication

I motoriduttori epicicloidali sono lubrificati in modo permanente, non richiedono quindi ulteriore manutenzione. Questo gli consente di essere installati praticamente ovunque. La temperatura ambiente di funzionamento consentita va da -50°C a + 40 °C; per applicazioni particolari, possono essere adottate misure per raggiungere livelli di temperatura maggiori.

Planetary gearmotors are life-time lubricated with grease, therefore they are maintenance free. They can be installed in any location. The environmental temperature range is from -50 °C up to +40°C; for special applications, measures can be taken for higher temperature range.

Carichi radiali

Radial loads

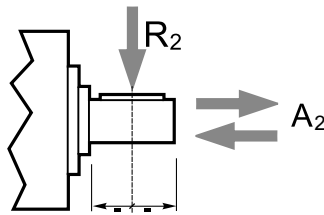

Numero di stadi N° of stages	Carichi Radiali R ₂ [N] / Radial Load R ₂ [N]					
	P52	P62	P72	P81	P105	P120
1	200	240	320	400	600	600
2	320	360	480	600	900	900
3	450	520	760	1000	1500	1500

Numero di stadi N° of stages	Carichi Assiali A ₂ [N] / Axial Load A ₂ [N]					
	P52	P62	P72	P81	P105	P120
1	60	70	70	80	120	120
2	100	100	100	120	180	180
3	150	150	160	200	300	300

ACP

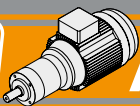
**ACP****MOTORIDUTTORI CA EPICICLOIDALI**
AC PLANETARY GEARMOTORS**Rapporti****Ratios**

Numero di stadi N° of stages	Per tutte le grandezze di riduttori della serie P For all gearbox sizes of P range
	Rapporti / Ratios
1	3.70
	4.28*
	5.18*
	6.75
2	13.73
	15.88*
	18.36*
	19.20*
	22.20*
	25.01
	26.85*
	28.93*
	34.97*
	45.56
3	50.89
	58.85*
	68.06*
	71.16*
	78.71*
	92.70
	95.17*
	99.50*
	107.20*
	115.07*
	123.97*
	129.62*
	139.13*
	149.90*
	168.84
	181.24*
195.26*	
236.09*	
307.54	

Rapporti preferenziali
Preferred ratios

	Rapporti preferenziali / Preferred ratios
--	---

* Rapporto non disponibile su grandezza P120 / Ratio not available on size P120

Disponibile a 4 stadi con rapporti fino a 2076 / Available 4 stages with ratio up to 2076

Dati tecnici

Technical data

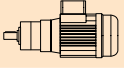
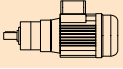
P ₁ [W]	n ₂ [min ⁻¹]	M ₂ [Nm]	sf	i		P ₁ [W]	n ₂ [min ⁻¹]	M ₂ [Nm]	sf	i		
0.06						0.09						
(1400 min ⁻¹)	378	1.2	4.2	3.70	5614/521	(1400 min ⁻¹)	378	1.8	2.8	3.70	5624/521	
	327	1.4	3.6	4.28			327	2.1	2.4	4.28		
	270	1.7	3.0	5.18			270	2.5	2.0	5.18		
	207	2.2	2.3	6.75			207	3.3	1.5	6.75		
	102	4.2	3.6	13.73	5614/522	102	6.3	2.4	13.73	5624/522		
	88.2	4.9	3.1	15.88			88.2	7.3	2.1		15.88	
	76.3	5.6	2.7	18.36			76.3	8.4	1.8		18.36	
	72.9	5.9	2.6	19.20			72.9	8.8	1.7		19.20	
	63.1	6.8	2.2	22.20			63.1	10	1.5		22.20	
	56.0	7.7	2.0	25.01			56.0	11	1.3		25.01	
	52.1	8.3	1.8	26.85			52.1	12	1.2		26.85	
	48.4	8.9	1.7	28.93			48.4	13	1.1		28.93	
	40.0	11	1.4	34.97			40.0	16	0.9		34.97	
	30.7	14	1.1	45.56			30.7	21	0.7		45.56	
	27.5	15	2.2	50.89	5614/523	27.5	22	1.5	50.89	5624/523		
	23.8	17	1.9	58.85			23.8	25	1.3		58.85	
	20.6	20	1.6	68.06			20.6	29	1.1		68.06	
	19.7	20	1.5	71.16			19.7	30	1.0		71.16	
	17.8	23	1.4	78.71			17.8	34	0.9		78.71	
	15.1	27	1.2	92.70			15.1	40	0.8		92.70	
	14.7	27	1.2	95.17			14.7	41	0.8		95.17	
	14.1	29	1.1	99.50			14.1	42	0.7		99.50	
	13.1	31	1.0	107.20			13.1	46	0.7		107.20	
	12.2	33	1.0	115.07			12.2	49	1.3		115.07	
	11.3	36	0.9	123.97		11.3	53	1.2	123.97			
	10.8	37	0.9	129.62		10.8	55	1.1	129.62			
	10.1	40	0.8	139.13		10.1	59	1.1	139.13			
	9.3	43	0.7	149.90		9.3	64	1.0	149.90			
	8.3	48	0.7	168.84		8.3	72	0.9	168.84			
	48.4	8.9	3.6	28.93	5614/622	48.4	13	2.4	28.93	5624/622		
	40.0	11	2.9	34.97			40.0	16	2.0		34.97	
	30.7	14	2.3	45.56			30.7	21	1.5		45.56	
	27.5	15	4.3	50.89			27.5	22	2.9		50.89	
	23.8	17	3.7	58.85	5614/623	23.8	25	2.5	58.85	5624/623		
	20.6	20	3.2	68.06			20.6	29	2.2		68.06	
	19.7	20	3.1	71.16			19.7	30	2.1		71.16	
	17.8	23	2.8	78.71			17.8	34	1.9		78.71	
	15.1	27	2.4	92.70			15.1	40	1.6		92.70	
	14.7	27	2.3	95.17			14.7	41	1.6		95.17	
	14.1	29	2.2	99.50			14.1	42	1.5		99.50	
	13.1	31	2.1	107.20			13.1	46	1.4		107.20	
	12.2	33	1.9	115.07			12.2	49	1.3		115.07	
	11.3	36	1.8	123.97			11.3	53	1.2		123.97	
	10.8	37	1.7	129.62		10.8	55	1.1	129.62			
	10.1	40	1.6	139.13		10.1	59	1.1	139.13			
	9.3	43	1.5	149.90		9.3	64	1.0	149.90			
	8.3	48	1.3	168.84		8.3	72	0.9	168.84			
	7.7	52	1.2	181.24		7.7	77	0.8	181.24			
	7.2	56	1.1	195.26		7.2	83	0.8	195.26			
	5.9	68	0.9	236.09		5.9	68	0.9	236.09			
	4.6	88	0.7	307.54		4.6	88	0.7	307.54			
	8.3	48	2.2	168.84	5614/723	15.1	40	2.7	92.70	5624/723		
	7.7	52	2.0	181.24			14.7	41	2.6		95.17	
	7.2	56	1.9	195.26			14.1	42	2.5		99.50	
	5.9	68	1.6	236.09			13.1	46	2.3		107.20	
	4.6	88	1.2	307.54			12.2	49	2.2		115.07	
	4.6	88	1.2	307.54			11.3	53	2.0		123.97	
	4.6	88	1.2	307.54		10.8	55	1.9	129.62			

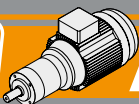
**ACP****MOTORIDUTTORI CA EPICICLOIDALI**
AC PLANETARY GEARMOTORS**Dati tecnici****Technical data**

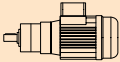
P ₁ [W]	n ₂ [min ⁻¹]	M ₂ [Nm]	sf	i	
0.09					
(1400 min ⁻¹)	10.1	59	1.8	139.13	5624/723
	9.3	64	1.7	149.90	
	8.3	72	1.5	168.84	
	7.7	77	1.4	181.24	
	7.2	83	1.3	195.26	
	5.9	101	1.1	236.09	
	4.6	131	0.8	307.54	
	8.3	72	2.1	168.84	5624/813
	7.7	77	2.0	181.24	
	7.2	83	1.8	195.26	
	5.9	101	1.5	236.09	
	4.6	131	1.2	307.54	

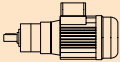
P ₁ [W]	n ₂ [min ⁻¹]	M ₂ [Nm]	sf	i	
0.12					
(1400 min ⁻¹)	378	2.4	4.2	3.70	6314/621
	327	2.8	3.7	4.28	
	270	3.4	3.0	5.18	
	207	4.4	2.3	6.75	
	102	8.3	3.8	13.73	6314/622
	88.2	9.6	3.3	15.88	
	76.3	11	2.8	18.36	
	72.9	12	2.7	19.20	
	63.1	13	2.3	22.20	
	56.0	15	2.1	25.01	
	52.1	16	1.9	26.85	
	48.4	18	1.8	28.93	
	40.0	21	1.5	34.97	
	30.7	28	1.1	45.56	
	27.5	29	2.2	50.89	6314/623
	23.8	33	1.9	58.85	
	20.6	39	1.6	68.06	
	19.7	40	1.6	71.16	
	17.8	45	1.4	78.71	
	15.1	53	1.2	92.70	
	14.7	54	1.2	95.17	
	14.1	56	1.1	99.50	
	13.1	61	1.0	107.20	
	12.2	65	1.0	115.07	
	11.3	70	0.9	123.97	6314/723
	10.8	73	0.9	129.62	
	10.1	79	0.8	139.13	
	9.3	85	0.7	149.90	
	8.3	96	0.7	168.84	
	27.5	29	3.7	50.89	
	23.8	33	3.2	58.85	
	20.6	39	2.8	68.06	
	19.7	40	2.6	71.16	
	17.8	45	2.4	78.71	
	15.1	53	2.0	92.70	
	14.7	54	2.0	95.17	
	14.1	56	1.9	99.50	
	13.1	61	1.7	107.20	
	12.2	65	1.6	115.07	
	11.3	70	1.5	123.97	
	10.8	73	1.4	129.62	

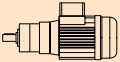
P ₁ [W]	n ₂ [min ⁻¹]	M ₂ [Nm]	sf	i	
0.12					
(1400 min ⁻¹)	10.1	79	1.3	139.13	6314/723
	9.3	85	1.3	149.90	
	8.3	96	1.1	168.84	
	7.7	103	1.0	181.24	
	7.2	111	1.0	195.26	
	5.9	134	0.8	236.09	
	4.6	152*	0.7	307.54	
	15.1	53	2.9	92.70	6314/813
	14.7	54	2.8	95.17	
	14.1	56	2.7	99.50	
	13.1	61	2.5	107.20	
	12.2	65	2.3	115.07	
	11.3	70	2.2	123.97	
	10.8	73	2.1	129.62	
	10.1	79	1.9	139.13	
	9.3	85	1.8	149.90	
	8.3	96	1.6	168.84	
	7.7	103	1.5	181.24	6314/1053
	7.2	111	1.4	195.26	
	5.9	134	1.1	236.09	
	4.6	174	0.9	307.54	
	8.3	96	2.6	168.84	
	7.7	103	2.4	181.24	
	7.2	111	2.2	195.26	
	5.9	134	1.8	236.09	
	4.6	174	1.4	307.54	

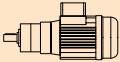
P ₁ [W]	n ₂ [min ⁻¹]	M ₂ [Nm]	sf	i	
0.18					
(1400 min ⁻¹)	378	3.7	2.7	3.70	6324/621
	327	4.3	2.3	4.28	
	270	5.2	1.9	5.18	
	207	6.8	1.5	6.75	
	102	13	2.4	13.73	6324/622
	88.2	15	2.1	15.88	
	76.3	17	1.8	18.36	
	72.9	18	1.7	19.20	
	63.1	21	1.5	22.20	
	56.0	24	1.3	25.01	
	52.1	25	1.2	26.85	
	48.4	27	1.2	28.93	
	40.0	33	1.0	34.97	
	30.7	43	0.7	45.56	
	27.5	45	1.4	50.89	6324/623
	23.8	52	1.2	58.85	
	20.6	60	1.1	68.06	
	19.7	63	1.0	71.16	
	17.8	69	0.9	78.71	
	15.1	82	0.8	92.70	
	14.7	84	0.8	95.17	
	14.1	88	0.7	99.50	
	13.1	95	0.7	107.20	

* Coppia limitata / Limited torque

Dati tecnici

Technical data

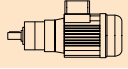
P ₁ [W]	n ₂ [min ⁻¹]	M ₂ [Nm]	sf	i	
0.18					
(1400 min ⁻¹)	72.9	18	2.9	19.20	6324/722
	63.1	21	2.5	22.20	
	56.0	24	2.2	25.01	
	52.1	25	2.1	26.85	
	48.4	27	1.9	28.93	
	40.0	33	1.6	34.97	6324/723
	30.7	43	1.2	45.56	
	27.5	45	2.4	50.89	
	23.8	52	2.0	58.85	
	20.6	60	1.8	68.06	
	19.7	63	1.7	71.16	
	17.8	69	1.5	78.71	
	15.1	82	1.3	92.70	
	14.7	84	1.3	95.17	
	14.1	88	1.2	99.50	
	13.1	95	1.1	107.20	6324/813
	12.2	101	1.0	115.07	
	11.3	109	1.0	123.97	
	10.8	114	0.9	129.62	
	10.1	123	0.9	139.13	
	9.3	132	0.8	149.90	
	8.3	149	0.7	168.84	
	20.6	60	2.5	68.06	
	19.7	63	2.4	71.16	
	17.8	69	2.2	78.71	
	15.1	82	1.9	92.70	6324/1053
	14.7	84	1.8	95.17	
	14.1	88	1.7	99.50	
	13.1	95	1.6	107.20	
	12.2	101	1.5	115.07	
	11.3	109	1.4	123.97	
	10.8	114	1.3	129.62	
	10.1	123	1.2	139.13	
	9.3	132	1.1	149.90	
	8.3	149	1.0	168.84	
	7.7	160	1.0	181.24	6324/1203
	7.2	172	0.9	195.26	
	5.9	208	0.7	236.09	
	4.6	217*	0.7	307.54	
	15.1	82	3.0	92.70	
	14.7	84	2.9	95.17	
	14.1	88	2.8	99.50	
	13.1	95	2.6	107.20	
	12.2	101	2.4	115.07	
	11.3	109	2.3	123.97	
	10.8	114	2.2	129.62	
	10.1	123	2.0	139.13	
	9.3	132	1.9	149.90	
	8.3	149	1.7	168.84	
	7.7	160	1.5	181.24	
	7.2	172	1.4	195.26	
	5.9	208	1.2	236.09	
	4.6	271	0.9	307.54	
	8.3	149	2.6	168.84	
	4.6	271	1.4	307.54	

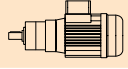
P ₁ [W]	n ₂ [min ⁻¹]	M ₂ [Nm]	sf	i	
0.25					
(1400 min ⁻¹)	378	5.0	2.0	3.70	6334/621
	327	5.8	1.7	4.28	
	270	7.0	1.4	5.18	
	207	9.2	1.1	6.75	
	102	18	1.8	13.73	6334/622
	88.2	20	1.6	15.88	
	76.3	23	1.4	18.36	
	72.9	24	1.3	19.20	
	63.1	28	1.1	22.20	
	56.0	32	1.0	25.01	
	52.1	34	0.9	26.85	6334/623
	48.4	37	0.9	28.93	
	40.0	45	0.7	34.97	
	27.5	61	1.0	50.89	
	23.8	70	0.9	58.85	
	20.6	81	0.8	68.06	
	19.7	85	0.7	71.16	6334/721
	17.8	90*	0.7	78.71	
	15.1	90*	0.7	92.70	
	378	5.0	3.5	3.70	
	327	5.8	3.0	4.28	6334/722
	270	7.0	2.5	5.18	
	207	9.2	1.9	6.75	
	102	18	3.0	13.73	
	88.2	20	2.6	15.88	6334/723
	76.3	23	2.3	18.36	
	72.9	24	2.2	19.20	
	63.1	28	1.9	22.20	
	56.0	32	1.7	25.01	
	52.1	34	1.6	26.85	
	48.4	37	1.4	28.93	
	40.0	45	1.2	34.97	
	30.7	58	0.9	45.56	
	27.5	61	1.8	50.89	
	23.8	70	1.5	58.85	
	20.6	81	1.3	68.06	
	19.7	85	1.3	71.16	
	17.8	94	1.1	78.71	
	15.1	110	1.0	92.70	
	14.7	113	0.9	95.17	
	14.1	118	0.9	99.50	
	13.1	128	0.8	107.20	
	12.2	137	0.8	115.07	
	11.3	148	0.7	123.97	
	10.8	154	0.7	129.62	
	56.0	32	2.4	25.01	6334/812
	52.1	34	2.2	26.85	
	48.4	37	2.1	28.93	
	40.0	45	1.7	34.97	
	30.7	58	1.3	45.56	

* Coppia limitata / Limited torque

ACP

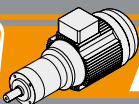
**ACP****MOTORIDUTTORI CA EPICICLOIDALI**
AC PLANETARY GEARMOTORS**Dati tecnici****Technical data**

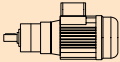
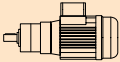
P_1 [W]	n_2 [min ⁻¹]	M_2 [Nm]	sf	i		P_1 [W]	n_2 [min ⁻¹]	M_2 [Nm]	sf	i	
0.25						0.25					
(1400 min ⁻¹)	27.5	61	2.5	50.89	6334/813	(1400 min ⁻¹)	27.5	61	1.8	50.89	7114/723
	23.8	70	2.2	58.85			23.8	70	1.5	58.85	
	20.6	81	1.9	68.06			20.6	81	1.3	68.06	
	19.7	85	1.8	71.16			19.7	85	1.3	71.16	
	17.8	94	1.6	78.71			17.8	94	1.1	78.71	
	15.1	110	1.4	92.70			15.1	110	1.0	92.70	
	14.7	113	1.3	95.17			14.7	113	0.9	95.17	
	14.1	118	1.3	99.50			14.1	118	0.9	99.50	
	13.1	128	1.2	107.20			13.1	128	0.8	107.20	
	12.2	137	1.1	115.07			12.2	137	0.8	115.07	
	11.3	148	1.0	123.97			11.3	148	0.7	123.97	
	10.8	154	1.0	129.62			10.8	154	0.7	129.62	
	10.1	166	0.9	139.13							
	9.3	178	0.9	149.90			56.0	32	2.4	25.01	7114/812
	8.3	201	0.8	168.84			52.1	34	2.2	26.85	
	7.7	216	0.7	181.24			48.4	37	2.1	28.93	
	7.2	232	0.7	195.26			40.0	45	1.7	34.97	
							30.7	58	1.3	45.56	
	20.6	81	3.0	68.06	6334/1053						
	19.7	85	2.9	71.16			27.5	61	2.5	50.89	7114/813
	17.8	94	2.6	78.71			23.8	70	2.2	58.85	
	15.1	110	2.2	92.70			20.6	81	1.9	68.06	
	14.7	113	2.2	95.17			19.7	85	1.8	71.16	
	14.1	118	2.1	99.50			17.8	94	1.6	78.71	
	13.1	128	1.9	107.20			15.1	110	1.4	92.70	
	12.2	137	1.8	115.07			14.7	113	1.3	95.17	
	11.3	148	1.7	123.97			14.1	118	1.3	99.50	
	10.8	154	1.6	129.62			13.1	128	1.2	107.20	
	10.1	166	1.5	139.13			12.2	137	1.1	115.07	
	9.3	178	1.4	149.90			11.3	148	1.0	123.97	
	8.3	201	1.2	168.84			10.8	154	1.0	129.62	
	7.7	216	1.1	181.24			10.1	166	0.9	139.13	
	7.2	232	1.1	195.26			9.3	178	0.9	149.90	
	5.9	281	0.9	236.09			8.3	201	0.8	168.84	
	4.6	366	0.7	307.54			7.7	216	0.7	181.24	
							7.2	232	0.7	195.26	
	15.1	110	3.4	92.70	6334/1203						
	8.3	201	1.9	168.84			20.6	81	3.0	68.06	7114/1053
	4.6	366	1.0	307.54			19.7	85	2.9	71.16	
							17.8	94	2.6	78.71	
	378	5.0	3.5	3.70	7114/721		15.1	110	2.2	92.70	
	327	5.8	3.0	4.28			14.7	113	2.2	95.17	
	270	7.0	2.5	5.18			14.1	118	2.1	99.50	
	207	9.2	1.9	6.75			13.1	128	1.9	107.20	
							12.2	137	1.8	115.07	
	102	18	3.0	13.73	7114/722		11.3	148	1.7	123.97	
	88.2	20	2.6	15.88			10.8	154	1.6	129.62	
	76.3	23	2.3	18.36			10.1	166	1.5	139.13	
	72.9	24	2.2	19.20			9.3	178	1.4	149.90	
	63.1	28	1.9	22.20			8.3	201	1.2	168.84	
	56.0	32	1.7	25.01			7.7	216	1.1	181.24	
	52.1	34	1.6	26.85			7.2	232	1.1	195.26	
	48.4	37	1.4	28.93			5.9	281	0.9	236.09	
	40.0	45	1.2	34.97			4.6	366	0.7	307.54	
	30.7	58	0.9	45.56							

Dati tecnici

Technical data

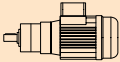
P ₁ [W]	n ₂ [min ⁻¹]	M ₂ [Nm]	sf	i	
0.25					
(1400 min ⁻¹)	15.1	110	3.4	92.70	7114/1203
	8.3	201	1.9	168.84	
	4.6	366	1.0	307.54	
0.37					
(1400 min ⁻¹)	378	7.5	2.4	3.70	7124/721
	327	8.6	2.1	4.28	
	270	10	1.7	5.18	
	207	14	1.3	6.75	
	102	26	2.0	13.73	7124/722
	88.2	30	1.8	15.88	
	76.3	35	1.5	18.36	
	72.9	36	1.5	19.20	
	63.1	42	1.3	22.20	
	56.0	47	1.1	25.01	
	52.1	51	1.0	26.85	
	48.4	55	1.0	28.93	
	40.0	66	0.8	34.97	
	30.7	86	0.6	45.56	
	27.5	90	1.2	50.89	7124/723
	23.8	104	1.0	58.85	
	20.6	120	0.9	68.06	
	19.7	126	0.8	71.16	
	17.8	139	0.8	78.71	
	15.1	164	0.7	92.70	
	102	26	2.9	13.73	7124/812
	88.2	30	2.5	15.88	
	76.3	35	2.2	18.36	
	72.9	36	2.1	19.20	
	63.1	42	1.8	22.20	
	56.0	47	1.6	25.01	
	52.1	51	1.5	26.85	
	48.4	55	1.4	28.93	
	40.0	66	1.1	34.97	
	30.7	86	0.9	45.56	
	27.5	90	1.7	50.89	7124/813
	23.8	104	1.5	58.85	
	20.6	120	1.3	68.06	
	19.7	126	1.2	71.16	
	17.8	139	1.1	78.71	
	15.1	164	0.9	92.70	
	14.7	168	0.9	95.17	
	14.1	176	0.9	99.50	
	13.1	189	0.8	107.20	
	12.2	203	0.7	115.07	
	11.3	219	0.7	123.97	
	10.8	229	0.7	129.62	

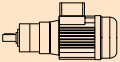
P ₁ [W]	n ₂ [min ⁻¹]	M ₂ [Nm]	sf	i		
0.37						
(1400 min ⁻¹)	56.0	47	2.8	25.01	7124/1052	
	52.1	51	2.6	26.85		
	48.4	55	2.4	28.93		
	40.0	66	2.0	34.97		
	30.7	86	1.5	45.56		
	27.5	90	2.7	50.89	7124/1053	
	23.8	104	2.4	58.85		
	20.6	120	2.1	68.06		
	19.7	126	2.0	71.16		
	17.8	139	1.8	78.71		
	15.1	164	1.5	92.70		
	14.7	168	1.5	95.17		
	14.1	176	1.4	99.50		
	13.1	189	1.3	107.20		
	12.2	203	1.2	115.07		
	11.3	219	1.1	123.97		
	10.8	229	1.1	129.62		
	10.1	245	1.0	139.13		
	9.3	264	0.9	149.90		
	8.3	298	0.8	168.84		
	7.7	320	0.8	181.24		
	7.2	344	0.7	195.26		
	15.1	164	2.3	92.70	7124/1203	
	8.3	298	1.3	168.84		
	4.6	543	0.7	307.54		
0.55						
(1400 min ⁻¹)	378	11	1.6	3.70	7134/721	
	327	13	1.4	4.28		
	270	16	1.1	5.18		
	207	20	0.9	6.75		
	102	39	1.4	13.73	7134/722	
	88.2	45	1.2	15.88		
	76.3	52	1.0	18.36		
	72.9	54	1.0	19.20		
	63.1	62	0.9	22.20		
	56.0	70	0.8	25.01		
	52.1	76	0.7	26.85		
	48.4	81	0.7	28.93		
	378	11	2.3	3.70		7134/811
	327	13	2.0	4.28		
	270	16	1.6	5.18		
	207	20	1.3	6.75		

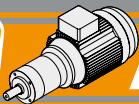
**ACP****MOTORIDUTTORI CA EPICICLOIDALI**
AC PLANETARY GEARMOTORS**Dati tecnici****Technical data**

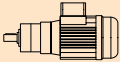
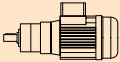
P_1 [W]	n_2 [min ⁻¹]	M_2 [Nm]	sf	i		P_1 [W]	n_2 [min ⁻¹]	M_2 [Nm]	sf	i	
0.55						0.55					
(1400 min ⁻¹)	102	39	2.0	13.73	7134/812	(1400 min ⁻¹)	102	39	2.0	13.73	8014/812
	88.2	45	1.7	15.88			88.2	45	1.7	15.88	
	76.3	52	1.5	18.36			76.3	52	1.5	18.36	
	72.9	54	1.4	19.20			72.9	54	1.4	19.20	
	63.1	62	1.2	22.20			63.1	62	1.2	22.20	
	56.0	70	1.1	25.01			56.0	70	1.1	25.01	
	52.1	76	1.0	26.85			52.1	76	1.0	26.85	
	48.4	81	0.9	28.93			48.4	81	0.9	28.93	
	40.0	98	0.8	34.97			40.0	98	0.8	34.97	
	30.7	128	0.6	45.56			30.7	108*	0.7	45.56	
	27.5	134	1.1	50.89	7134/813		27.5	134	1.1	50.89	8014/813
	23.8	154	1.0	58.85			23.8	154	1.0	58.85	
	20.6	179	0.9	68.06			20.6	179	0.9	68.06	
	19.7	187	0.8	71.16			19.7	187	0.8	71.16	
	17.8	207	0.7	78.71			17.8	207	0.7	78.71	
	15.1	217*	0.7	92.70			15.1	217*	0.7	92.70	
	72.9	54	2.5	19.20	7134/1052		72.9	54	2.5	19.20	8014/1052
	63.1	62	2.1	22.20			63.1	62	2.1	22.20	
	56.0	70	1.9	25.01			56.0	70	1.9	25.01	
	52.1	76	1.8	26.85			52.1	76	1.8	26.85	
	48.4	81	1.6	28.93			48.4	81	1.6	28.93	
	40.0	98	1.4	34.97			40.0	98	1.4	34.97	
	30.7	128	1.0	45.56			30.7	128	1.0	45.56	
	27.5	134	1.8	50.89	7134/1053		27.5	134	1.8	50.89	8014/1053
	23.8	154	1.6	58.85			23.8	154	1.6	58.85	
	20.6	179	1.4	68.06			20.6	179	1.4	68.06	
	19.7	187	1.3	71.16			19.7	187	1.3	71.16	
	17.8	207	1.2	78.71			17.8	207	1.2	78.71	
	15.1	243	1.0	92.70			15.1	243	1.0	92.70	
	14.7	250	1.0	95.17			14.7	250	1.0	95.17	
	14.1	261	0.9	99.50			14.1	261	0.9	99.50	
	13.1	281	0.9	107.20			13.1	281	0.9	107.20	
	12.2	302	0.8	115.07			12.2	302	0.8	115.07	
	11.3	325	0.8	123.97			11.3	325	0.8	123.97	
	10.8	340	0.7	129.62			10.8	340	0.7	129.62	
	10.1	365	0.7	139.13			10.1	353*	0.7	139.13	
	9.3	353*	0.7	149.90			9.3	353*	0.7	149.90	
	8.3	353*	0.7	168.84			8.3	353*	0.7	168.84	
	30.7	120	1.6	45.56	7134/1202		30.7	120	1.6	45.56	8014/1202
	27.5	134	2.8	50.89	7134/1203		27.5	134	2.8	50.89	8014/1203
	15.1	243	1.6	92.70			15.1	243	1.6	92.70	
	8.3	443	0.9	168.84			8.3	443	0.9	168.84	
	378	11	2.3	3.70	8014/811						
	327	13	2.0	4.28							
	270	16	1.6	5.18							
	207	20	1.3	6.75							

* Coppia limitata / Limited torque

Dati tecnici

Technical data

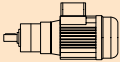
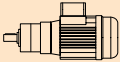
P_1 [W]	n_2 [min ⁻¹]	M_2 [Nm]	sf	i		P_1 [W]	n_2 [min ⁻¹]	M_2 [Nm]	sf	i	
0.75						1.1					
(1400 min ⁻¹)	378	15	1.7	3.70	8024/811	(1400 min ⁻¹)	378	22	1.1	3.70	8034/811
	327	18	1.4	4.28			327	26	1.0	4.28	
	270	21	1.2	5.18			270	31	0.8	5.18	
	207	28	0.9	6.75			207	36*	0.7	6.75	
	102	53	1.4	13.73	8024/812		102	77	1.0	13.73	8034/812
	88.2	61	1.2	15.88			88.2	89	0.9	15.88	
	76.3	71	1.1	18.36			76.3	103	0.7	18.36	
	72.9	74	1.0	19.20			72.9	108	0.7	19.20	
	63.1	85	0.9	22.20							
	56.0	96	0.8	25.01			378	22	2.0	3.70	8034/1051
	52.1	103	0.7	26.85			327	26	1.7	4.28	
	48.4	111	0.7	28.93			270	31	1.4	5.18	
							207	41	1.1	6.75	
	27.5	182	0.8	50.89	8024/813		102	77	1.7	13.73	8034/1052
	23.8	211	0.7	58.85			88.2	89	1.5	15.88	
	20.6	217*	0.7	68.06			76.3	103	1.3	18.36	
	378	15	2.9	3.70	8024/1051		72.9	108	1.2	19.20	
	327	18	2.5	4.28			63.1	125	1.1	22.20	
	270	21	2.1	5.18			56.0	141	0.9	25.01	
	207	28	1.6	6.75			52.1	151	0.9	26.85	
	102	53	2.5	13.73	8024/1052		48.4	163	0.8	28.93	
	88.2	61	2.2	15.88			40.0	197	0.7	34.97	
	76.3	71	1.9	18.36			30.7	256	0.5	45.56	
	72.9	74	1.8	19.20							
	63.1	85	1.6	22.20			27.5	267	0.9	50.89	8034/1053
	56.0	96	1.4	25.01			23.8	309	0.8	58.85	
	52.1	103	1.3	26.85			20.6	357	0.7	68.06	
	48.4	111	1.2	28.93							
	40.0	134	1.0	34.97			207	35	1.8	6.75	8034/1201
	30.7	175	0.8	45.56			102	72	2.6	13.73	8034/1202
							56.0	131	1.4	25.01	
	27.5	182	1.4	50.89	8024/1053		30.7	239	0.8	45.56	
	23.8	211	1.2	58.85							
	20.6	244	1.0	68.06			27.5	267	1.4	50.89	8034/1203
	19.7	255	1.0	71.16			15.1	487	0.8	92.70	
	17.8	282	0.9	78.71							
	15.1	332	0.7	92.70			207	35	1.8	6.75	90S4/1201
	207	24	2.6	6.75	8024/1201		102	72	2.6	13.73	90S4/1202
	102	49	3.9	13.73	8024/1202		56.0	131	1.4	25.01	
	56.0	90	2.1	25.01			30.7	239	0.8	45.56	
	30.7	163	1.2	45.56							
							27.5	267	1.4	50.89	90S4/1203
	27.5	182	2.1	50.89	8024/1203		15.1	487	0.8	92.70	
	15.1	332	1.1	92.70							
	8.3	542*	0.7	168.84							

ACP

* Coppia limitata / Limited torque

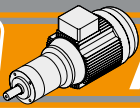

Dati tecnici

Technical data

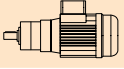
P ₁ [W]	n ₂ [min ⁻¹]	M ₂ [Nm]	sf	i	
1.5					
(1400 min ⁻¹)	378	26	2.4	3.70	90L14/1201
	207	48	1.3	6.75	
	102	98	1.9	13.73	90L14/1202
	56.0	179	1.1	25.01	
	30.7	271*	0.7	45.56	
	27.5	364	1.0	50.89	
	15.1	543*	0.7	92.70	90L14/1203

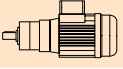
P ₁ [W]	n ₂ [min ⁻¹]	M ₂ [Nm]	sf	i	
2.2					
(1400 min ⁻¹)	378	39	1.6	3.70	90L24/1201
	207	71	0.9	6.75	
	102	144	1.3	13.73	90L24/1202
	56.0	263	0.7	25.01	
	27.5	535	0.7	50.89	

* Coppia limitata / Limited torque

Motori applicabili

IEC Motor adapters

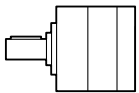
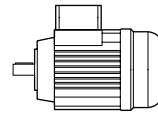

		TS				
		56...	63...	71...	80...	90...
P	52...					
	62...					
	72...					
	81...					
	105...					
	120...					



Dimensioni

Dimensions

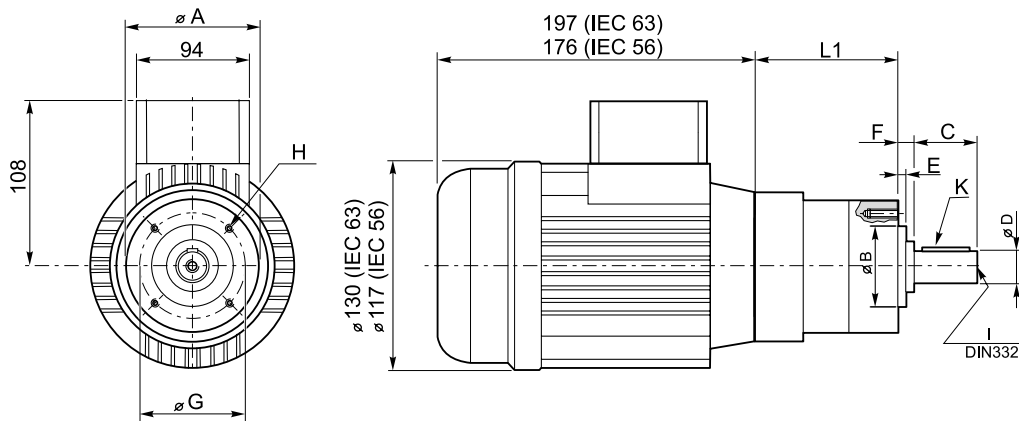

ACP56.../... U

Tipo Type	Numero di stadi N° of stages	Dimensioni / Dimensions										
		L1	A	B	C	D	E	F	G	H	I	K
ACP56../52...	1	74	52	32 h8	20.8	12 h7	3	4.2	40	M5x10	M4x10	4x4x16
	2	88										
	3	102										
ACP56../62...	1	74	62	40 j7	30	14 h7	5	9	52	M5x10	M5x12	5x5x18
	2	90										
	3	106										
ACP56../72...	1	85.4	72	45 j7	40	16 h7	5	9	60	M5x10	M5x12	5x5x30
	2	105										
	3	124.6										
ACP56../81...	1	94	81	50 j7	40	19 h7	5	9	65	M6x12	M6x16	6x6x28
	2	116										
	3	138										
ACP56../105...	1	116.4	105	70 j7	50	25 h7	5	9	85	M8x16	M10x22	8x7x40
	2	147.5										
	3	178.5										
ACP56../120...	1	134.4	120	80 j7	73	32 k6	5	15	100	M10x22	M12	10x8x50
	2	168.6										
	3	202.8										

ACP 63.../... U

Tipo Type	Numero di stadi N° of stages	Dimensioni / Dimensions										
		L1	A	B	C	D	E	F	G	H	I	K
ACP63../62...	1	76	62	40 j7	30	14 h7	5	9	52	M5x10	M5x12	5x5x18
	2	92										
	3	108										
ACP63../72...	1	88.4	72	45 j7	40	16 h7	5	9	60	M5x10	M5x12	5x5x30
	2	108										
	3	127.6										
ACP63../81...	1	94	81	50 j7	40	19 h7	5	9	65	M6x12	M6x16	6x6x28
	2	116										
	3	138										
ACP63../105...	1	116.4	105	70 j7	50	25 h7	5	9	85	M8x16	M10x22	8x7x40
	2	147.5										
	3	178.5										
ACP63../120...	1	134.4	120	80 j7	73	32 k6	5	15	100	M10x22	M12	10x8x50
	2	168.6										
	3	202.8										

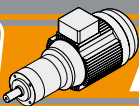

Dimensioni

Dimensions

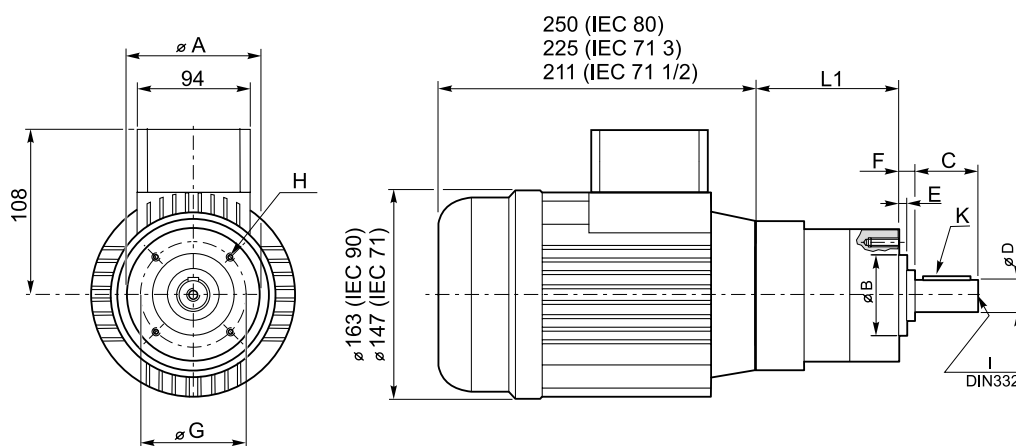

ACP 71.../... U

Tipo Type	Numero di stadi N° of stages	Dimensioni / Dimensions										
		L1	A	B	C	D	E	F	G	H	I	K
ACP71../72...	1	95.4	72	45 j7	40	16 h7	5	9	60	M5x10	M5x12	5x5x30
	2	115										
	3	134.6										
ACP71../81...	1	101	81	50 j7	40	19 h7	5	9	65	M6x12	M6x16	6x6x28
	2	123										
	3	145										
ACP71../105...	1	123.4	105	70 j7	50	25 h7	5	9	85	M8x16	M10x22	8x7x40
	2	154.5										
	3	185.5										
ACP71../120...	1	136.5	120	80 j7	73	32 k6	5	15	100	M10x22	M12	10x8x50
	2	170.7										
	3	204.9										

ACP 80.../... U

Tipo Type	Numero di stadi N° of stages	Dimensioni / Dimensions										
		L1	A	B	C	D	E	F	G	H	I	K
ACP80../81...	1	111	81	50 j7	40	19 h7	5	9	65	M6x12	M6x16	6x6x28
	2	133										
	3	155										
ACP80../105...	1	133.9	105	70 j7	50	25 h7	5	9	85	M8x16	M10x22	8x7x40
	2	165										
	3	196										
ACP80../120...	1	146.5	120	80 j7	73	32 k6	5	15	100	M10x22	M12	10x8x50
	2	180.7										
	3	214.9										



Dimensioni

Dimensions

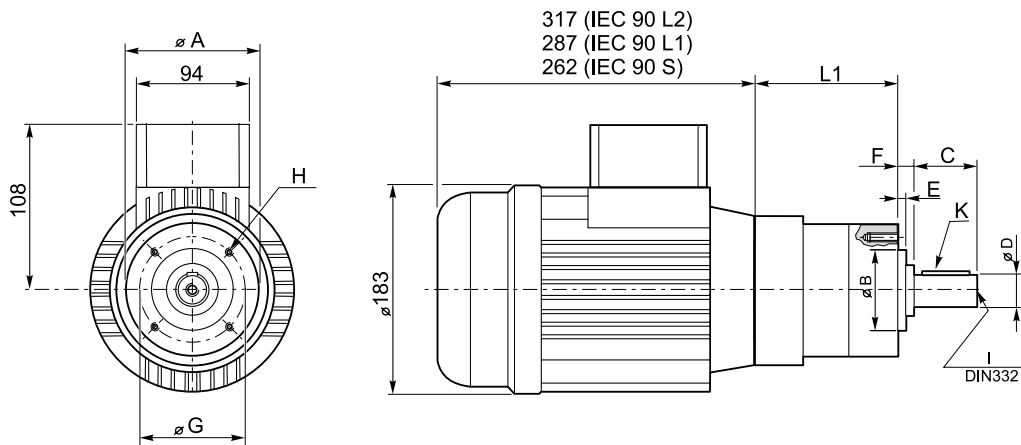

ACP 90.../... U

Tipo Type	Numero di stadi N° of stages	Dimensioni / Dimensions										
		L1	A	B	C	D	E	F	G	H	I	K
ACP90../120...	1	156.5	120	80 j7	73	32 k6	5	15	100	M10x22	M12	10x8x50
	2	190.7										
	3	224.9										

ACP

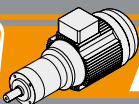

Dimensioni

Dimensions

ACP../... C... Flange uscita / Output flanges

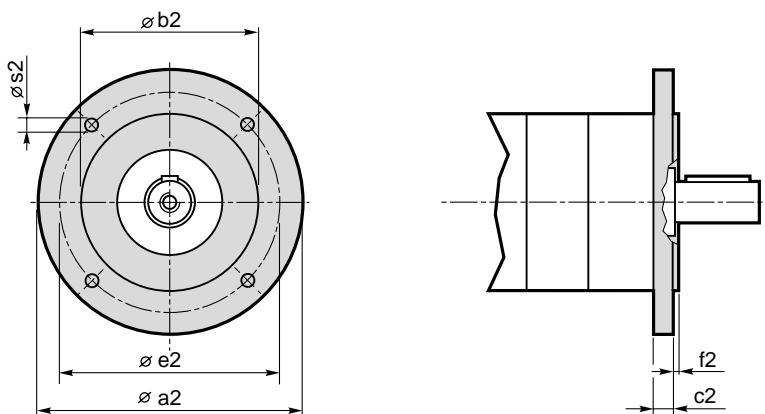

Dimensioni / Dimensions							
P	a2	b2	c2	e2	f2	s2	Flangia uscita Output flange
52	80	50 j7	9	65	2.5	M5	C80
	90	60 j7	9	75	2.5	5.5	C90
	105	70 j7	9	85	2.5	6.5	C105
	120	80 j7	9	100	3.0	6.5	C120
62	80	50 j7	9	65	2.5	M5	C80
	90	60 j7	9	75	2.5	5.5	C90
	105	70 j7	9	85	2.5	6.5	C105
	120	80 j7	9	100	3.0	6.5	C120
72	80	50 j7	9	65	2.5	M5	C80
	90	60 j7	9	75	2.5	M5	C90
	105	70 j7	9	85	2.5	6.5	C105
	120	80 j7	9	100	3.0	6.5	C120
81	90	60 j7	9	75	2.5	M5	C90
	105	70 j7	9	85	2.5	M6	C105
	120	80 j7	9	100	3.0	6.5	C120
105	120	80 j7	12	100	3	M6	C120
	140	95 j7	12	115	3.5	M8	C140
	160	110 j7	12	130	3.5	M8	C160
120	140	95 j7	15	115	3	M8	C140
	160	110 j7	15	130	3.5	M8	C160

TRANSTECNO[®]
the modular gearmotor

WMP



Small but Strong

WMP

Motoriduttori combinati in CA AC double reduction gearmotors



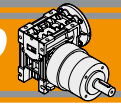

Indice	Index	Pag. Page
Caratteristiche tecniche	<i>Technical features</i>	E2
Designazione	<i>Classification</i>	E2
Versioni	<i>Versions</i>	E2
Simbologia	<i>Symbols</i>	E2
Lubrificazione	<i>Lubrication</i>	E3
Carichi radiali	<i>Radial loads</i>	E3
Rapporti	<i>Ratios</i>	E3
Dati tecnici	<i>Technical data</i>	E4
Dimensioni	<i>Dimensions</i>	E5

Questa sezione annulla e sostituisce ogni precedente edizione o revisione. Qualora questa sezione non Vi sia giunta in distribuzione controllata, l'aggiornamento dei dati ivi contenuto non è assicurato. **In tal caso la versione più aggiornata è disponibile sul nostro sito internet www.transtecno.com**

*This section replaces any previous edition and revision. If you obtained this catalogue other than through controlled distribution channels, the most up to date content is not guaranteed. **In this case the latest version is available on our web site www.transtecno.com***

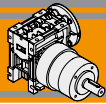

Caratteristiche tecniche

Technical features

L'accoppiamento di un riduttore a vite senza fine con un riduttore epicicloidale consente di ottenere elevati rapporti di riduzione ($i_{max} = 1/18452$) e di disporre di un gruppo autolubrificato compatto, silenzioso e con un'elevata affidabilità.

The coupling of a wormgearbox to a planetary gearbox allows to obtain high reduction ratios ($i_{max} = 1/18452$) and to get a compact, silent, self lubricated with high reliability group.

Designazione

Classification

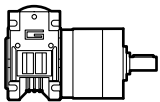
MOTORIDUTTORE / GEARMOTOR					
WMP	026/52	1	CS90	202.5	56B14
Tipo Type	Grandezza Size	Numero stadi epicicloidale N° of planetary stages	Versione Version	Rapporto Ratio	IEC
	026/52 026/62 030/81	1 2 3	US UD CS80...120 CD80...120	Vedere tabella See tables	56B14 63B14 63B5

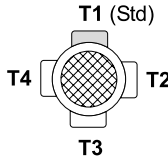
MOTORE CM / CM MOTOR				
0.09kW	4p	3ph	50Hz	T1
Potenza Power	Poli Poles	Fasi Phases	Frequenza Frequency	Pos. morsettiera Terminal box pos.
Vedi tabelle See tables	2p 4p 6p 8p	1ph 3ph	50Hz 60Hz	

Versioni

Versions

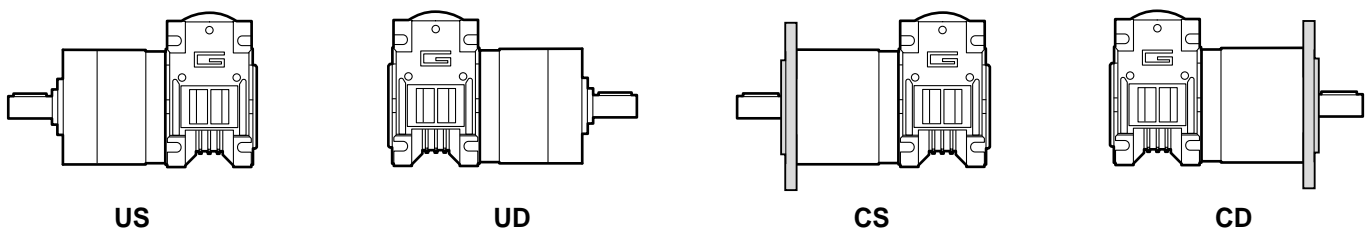

Simbologia

Symbols

n_1	[min ⁻¹]	Velocità in ingresso / <i>Input speed</i>
n_2	[min ⁻¹]	Velocità in uscita / <i>Output speed</i>
i		Rapporto di riduzione / <i>Ratio</i>
P_1	[kW]	Potenza in entrata / <i>Input power</i>
M_n	[Nm]	Coppia nominale in uscita del riduttore / <i>Maximum output torque of the gearbox</i>
M_2	[Nm]	Coppia in uscita in funzione di P_1 / <i>Output torque referred to P_1</i>
sf		Fattore di servizio / <i>Service factor</i>
R_d	%	Rendimento dinamico / <i>Dynamic efficiency</i>
A_2	[N]	Carico assiale ammissibile in uscita / <i>Permitted output axial load</i>
R_2	[N]	Carico radiale ammissibile in uscita / <i>Permitted output radial load</i>

Lubrificazione

Lubrication

I riduttori a vite senza fine della serie CM sono lubrificati a vita con olio sintetico di viscosità 320 e possono essere installati in qualunque posizione di montaggio.

Permanent synthetic oil long-life lubrication allow to use CM wormgearbox range in all mounting position.

I riduttori epicicloidali sono lubrificati in modo permanente, non richiedono quindi ulteriore manutenzione.

Planetary gearboxes are life-time lubricated with grease, therefore they are maintenance free.

Questo gli consente di essere installati praticamente ovunque. La temperatura ambiente di funzionamento consentita va da -50°C a + 40°C; per applicazioni particolari possono essere adottate misure per raggiungere livelli di temperatura maggiori.

They can be installed in any location. The environmental temperature range is from -50°C up to +40°C; for special applications, measures can be taken for higher temperature range.

Carichi radiali

Radial loads

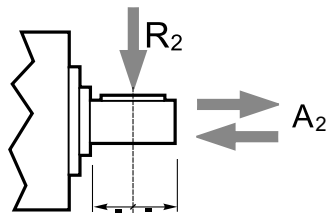

Numero di stadi N° of stages	Carichi Radiali R ₂ [N] Radial Load R ₂ [N]		
	P52	P62	P81
1	200	240	400
2	320	360	600
3	450	520	1000

Numero di stadi N° of stages	Carichi Assiali A ₂ [N] Axial Load A ₂ [N]		
	P52	P62	P81
1	60	70	80
2	100	100	120
3	150	150	200

Rapporti



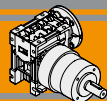

Ratios

Motoriduttore Gearmotor	Numero stadi epicicloidale N° of planetary stages	Rapporto epicicloidale Planetary ratio	Rapporto vite senza fine Wormgearbox ratio	Rapporto finale Total ratio
WMP 026/052 WMP 026/062 WMP 030/081	1	6.75	10	67.5
			15	101.3
			20	135
			30	202.5
			40	270
			50	337.5
	2	28.93	10	289.3
			15	434.0
			20	578.6
			30	867.9
			40	1157
			50	1447
			60	1736
			60	2098
	34.97	60	2098	
	45.56	60	2734	

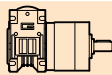

Dati tecnici

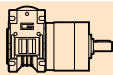
Technical data

P_1 [W]	n_2 [min ⁻¹]	M_2 [Nm]	sf	i			P_1 [W]	n_2 [min ⁻¹]	M_2 [Nm]	sf	i		
0.09							0.12						
56B (1400 min ⁻¹)	20.7	25	1.0	67.5	026/521	B14	63A	20.7	37	2.2	67.5	030/811	63B5/B14
	13.8	25	1.0	101.3			63A (1400 min ⁻¹)	13.8	52	1.5	101.3		
	10.4	25	1.0	135				10.4	66	1.2	135		63B5/B14
	6.9	25	1.0	202.5				6.9	80	1.0	202.5		63B5/B14
	5.2	25	1.0	270				5.2	80	1.0	270		63B5/B14
	4.8	25	1.0	289.3	026/522	B14		4.8	120	1.0	289.3	030/812	63B5/B14
	4.1	25	1.0	337.5	026/521	B14	0.18						
	3.5	25	1.0	405			63B	20.7	56	1.4	67.5	030/811	63B5/B14
	3.2	25	1.0	434	026/522	B14	63B (1400 min ⁻¹)	13.8	79	1.0	101.3		
	2.4	25	1.0	578.6				10.4	80	1.0	135		63B5/B14
	1.6	25	1.0	867.9									
	1.2	25	1.0	1157									
	1.0	25	1.0	1447									
	0.8	25	1.0	1736									
	0.7	25	1.0	2098									
	0.5	25	1.0	2734									
	20.7	27	1.5	67.5	026/621	B14							
	13.8	39	1.0	101.3									
	10.4	40	1.0	135									
	6.9	40	1.0	202.5									
	5.2	40	1.0	270									
	4.8	50	1.0	289.3	026/622	B14							
	4.1	40	1.0	337.5	026/621	B14							
	3.5	40	1.0	405									
	3.2	50	1.0	434	026/622	B14							
	2.4	50	1.0	578.6									
	1.6	50	1.0	867.9									
	1.2	50	1.0	1157									
	1.0	50	1.0	1447									
	0.8	50	1.0	1736									
	0.7	50	1.0	2098									
	0.5	50	1.0	2734									
	20.7	28	2.9	67.5	030/811	B5/B14							
	13.8	39	2.0	101.3									
	10.4	49	1.6	135									
	6.9	66	1.2	202.5									
	5.2	80	1.0	270									
	4.8	111	1.1	289.3	030/812	B5/B14							
	4.1	80	1.0	337.5	030/811	B5/B14							
	3.5	80	1.0	405									
	3.2	120	1.0	434	030/812	B5/B14							
	2.4	120	1.0	578.6									
	1.6	120	1.0	867.9									
	1.2	120	1.0	1157									
	1.0	120	1.0	1447									
	0.8	120	1.0	1736									
	0.7	120	1.0	2098									
	0.5	120	1.0	2734									

Nota: Verificare sempre che la coppia M2 utilizzata non ecceda il valore indicato nelle caselle in grigio

Note: Please check that the output torque M2 does not exceed the value into the grey areas

Dimensioni

Dimensions

WMP026/52...U

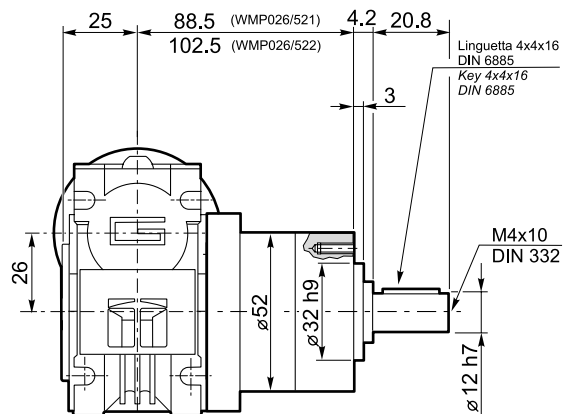
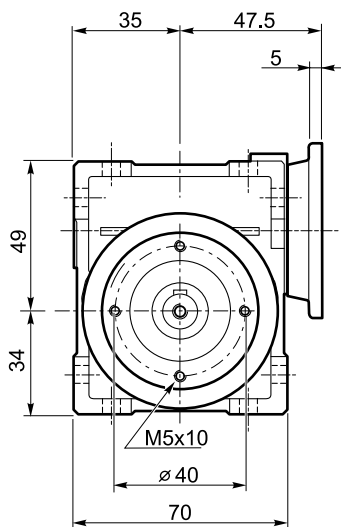

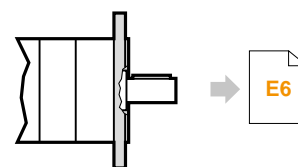

	
WMP026/521	1.6
WMP026/522	1.8

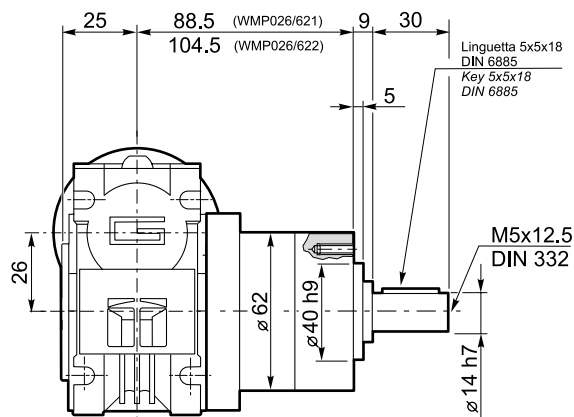
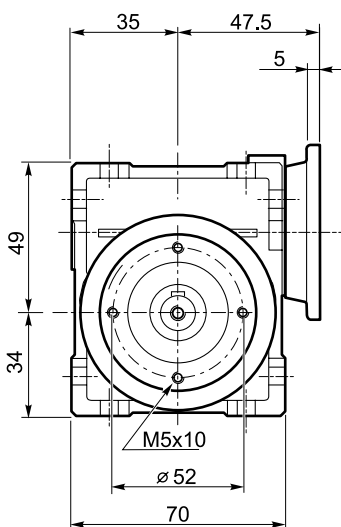

WMP026/52...C

WMP026/62...U



	
WMP026/621	1.7
WMP026/622	2.1

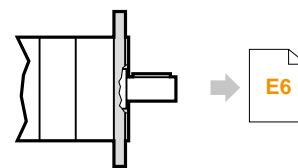

WMP026/62...C

WMP

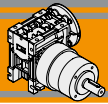

Dimensioni

Dimensions

WMP030/81...U

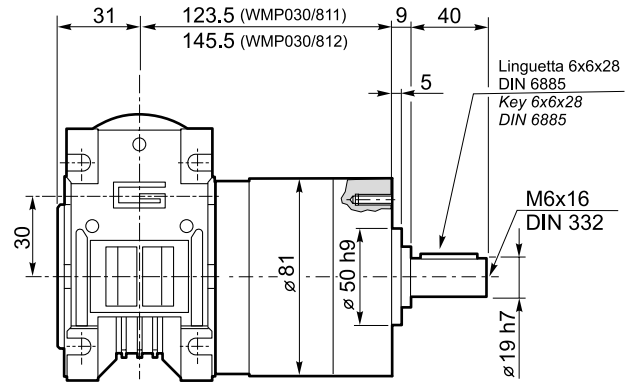
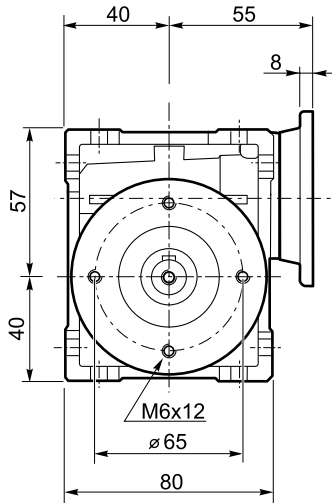

	Kg
WMP030/811	3.1
WMP030/812	3.8

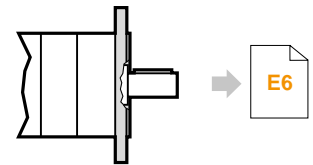

WMP030/81...C

WMP.../.../... C... Flange uscita / Output flanges

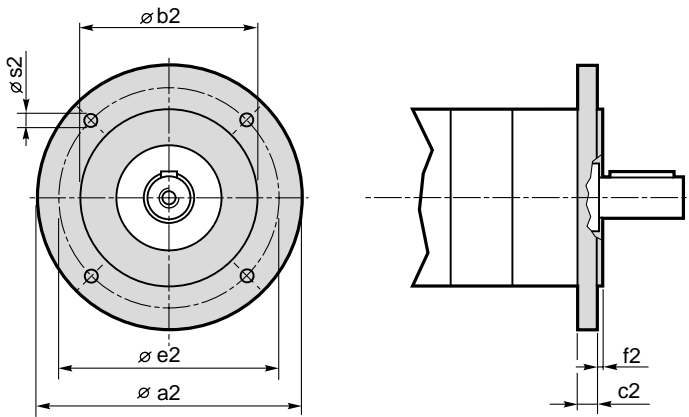

Dimensioni / Dimensions							
P	a2	b2	c2	e2	f2	s2	Flangia uscita / Output flange
52	80	50 j7	9	65	2.5	M5	C80
	90	60 j7	9	75	2.5	5.5	C90
	105	70 j7	9	85	2.5	6.5	C105
	120	80 j7	9	100	3.0	6.5	C120
62	80	50 j7	9	65	2.5	M5	C80
	90	60 j7	9	75	2.5	5.5	C90
	105	70 j7	9	85	2.5	6.5	C105
81	90	60 j7	9	75	2.5	M5	C90
	105	70 j7	9	85	2.5	M6	C105
	120	80 j7	9	100	3.0	6.5	C120

TRANSTECNO[®]
the modular gearmotor

NDP



Small but Strong

NDP

Motoriduttori CC epicicloidali
a magneti permanenti in neodimio
Neodymium permanent magnets
DC planetary gearmotors



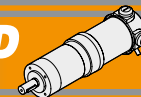

Indice	Index	Pag. Page
Caratteristiche tecniche	<i>Technical features</i>	F2
Designazione	<i>Classification</i>	F2
Versioni	<i>Versions</i>	F2
Simbologia	<i>Symbols</i>	F2
Lubrificazione	<i>Lubrication</i>	F2
Carichi radiali	<i>Radial loads</i>	F3
Rapporti	<i>Ratios</i>	F3
Dati tecnici	<i>Technical data</i>	F4
Dimensioni	<i>Dimensions</i>	F7

Questa sezione annulla e sostituisce ogni precedente edizione o revisione. Qualora questa sezione non Vi sia giunta in distribuzione controllata, l'aggiornamento dei dati ivi contenuto non è assicurato. **In tal caso la versione più aggiornata è disponibile sul nostro sito internet www.transtecno.com**

*This section replaces any previous edition and revision. If you obtained this catalogue other than through controlled distribution channels, the most up to date content is not guaranteed. **In this case the latest version is available on our web site www.transtecno.com***



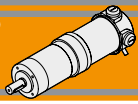

Caratteristiche tecniche

Technical features

Le caratteristiche principali dei motoriduttori CC epicicloidali a magneti permanenti in neodimio serie NDP sono:

The main features of NDP Neodymium permanent magnets DC planetary gearmotors range are:

- Alimentazione in bassa tensione 12/24 Vcc
- Possibilità di montaggio encoder
- Potenze motore disponibili da 160 a 250 W S2
- Magneti in Neodimio
- Entrata ed uscita coassiali
- Design compatto
- Lubrificazione permanente a grasso
- Possono essere installati in qualunque posizione di montaggio.

- Low voltage power supply 12/24 Vdc
- Suitable for encoder assembly
- Motor power ratings available from 160 to 250 W S2
- Neodymium magnets
- Coaxial arrangement of the input and output
- Compact design
- Permanent grease oil long-life lubrication
- Can be intalled in all mounting position.

Designazione

Classification

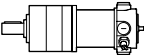
MOTORIDUTTORE / GEARMOTOR								
NDP	120/62		2	C	90	34.97	120	BR
Tipo Type	Grandezza Size		Stadi riduttore Gearbox stages	Versione riduttore Gearbox Version	Flangia uscita Output flange	Rapporto Ratio	Versione Motore Motor Version	Opzioni Options
NDP 	120/52 120/62 120/72 120/81	180/52 180/62 180/72 180/81 180/105 180/120	1 2 3	U C	80 90 105 120	Vedere tabella See tables	120 240	BR BRL

Versioni

Versions

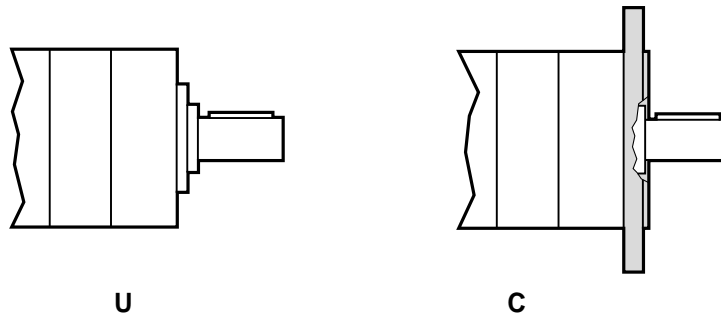

Simbologia

Symbols

n_1 [min ⁻¹]	Velocità in ingresso / <i>Input speed</i>	sf	Fattore di servizio / <i>Service factor</i>
n_2 [min ⁻¹]	Velocità in uscita / <i>Output speed</i>	Rd %	Rendimento dinamico / <i>Dynamic efficiency</i>
i	Rapporto di riduzione / <i>Ratio</i>	A ₂ [N]	Carico assiale ammissibile in uscita / <i>Permitted output axial load</i>
P ₁ [kW]	Potenza in entrata / <i>Input power</i>	R ₂ [N]	Carico radiale ammissibile in uscita / <i>Permitted output radial load</i>
M ₂ [Nm]	Coppia in uscita in funzione di P ₁ / <i>Output torque referred to P₁</i>		

Lubrificazione

Lubrication

I riduttori epicicloidali sono lubrificati in modo permanente, non richiedono quindi ulteriore manutenzione. Questo gli consente di essere installati praticamente ovunque.

Planetary gearboxes are life-time lubricated with grease, therefore they are maintenance free. They can be installed in any location.

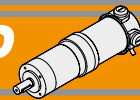

Carichi radiali

Radial loads

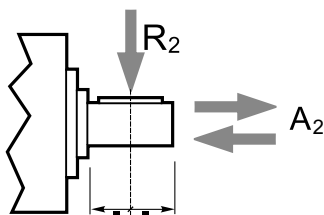

Numero di stadi Stages number	Carichi Radiali R_2 [N] / Radial Load R_2 [N]			
	P52	P62	P72	P81
1	200	240	320	400
2	320	360	480	600
3	450	520	760	1000

Numero di stadi Stages number	Carichi Assiali [A_2] [N] / Axial Load [A_2] [N]			
	P52	P62	P72	P81
1	60	70	70	80
2	100	100	100	120
3	150	150	160	200

Rapporti

Ratios

Numero di stadi Stages number	Per tutte le grandezze di riduttori della serie P For all gearbox sizes of P range
	Rapporti / Ratios
1	3.70
	4.28
	5.18
	6.75
2	13.73
	15.88
	18.36
	19.20
	22.20
	25.01
	26.85
	28.93
	34.97
	45.56
3	50.89
	58.85
	68.06
	71.16
	78.71
	92.70
	95.17
	99.50
	107.20
	115.07
	123.97
	129.62
	139.13
	149.90
	168.84
	181.24
195.26	
236.09	
307.54	

Rapporti preferenziali
Preferred ratios

Disponibile a 4 stadi con rapporti fino a 2076
Available 4 stages with ratio up to 2076

NDP

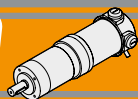

Dati tecnici per servizio S2

Technical data for S2 duty

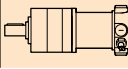
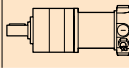
P_1 [W]	n_2 [min ⁻¹]	M_2 [Nm]	sf	i		Versione motore Motor version	P_1 [W]	n_2 [min ⁻¹]	M_2 [Nm]	sf	i		Versione motore Motor version
160							160						
(3000 min ⁻¹)	811	2	2.6	3.70	NDP120/521	120/240	(3000 min ⁻¹)	59	18	2.8	50.89	NDP120/623	120/240
	701	2	2.3	4.28			51	21	2.4	58.85			
	579	2	1.9	5.18			44	24	2.1	68.06			
	444	3	1.5	6.75			42	25	2.0	71.16			
	218	5	2.3	13.73	NDP120/522	120/240	38	28	1.8	78.71			
	189	6	2.0	15.88			32	33	1.5	92.70			
	163	7	1.7	18.36			32	34	1.5	95.17			
	156	7	1.6	19.20			30	36	1.4	99.50			
	135	8	1.4	22.20			28	38	1.3	107.20			
	120	10	1.3	25.01			26	41	1.2	115.07			
	112	10	1.2	26.85			24	44	1.1	123.97			
	104	11	1.1	28.93			23	46	1.1	129.62			
	86	13	0.9	34.97			22	50	1.0	139.13			
	66	17	0.7	45.56			20	54	0.9	149.90			
	59	18	1.4	50.89			NDP120/523	120/240	18	60	0.8	168.84	
	51	21	1.2	58.85					17	65	0.8	181.24	
	44	24	1.0	68.06					15	70	0.7	195.26	
	42	25	1.0	71.16					13	71	0.7	236.09	
	38	28	0.9	78.71	9.8	71			0.7	307.54			
	32	33	0.8	92.70	44	24			3.5	68.06	NDP120/723	120/240	
	32	34	0.7	95.17	42	25			3.3	71.16			
	30	36	0.7	99.50	38	28			3.0	78.71			
	28	36	0.7	107.20	32	33			2.5	92.70			
	26	36	0.7	115.07	32	34			2.5	95.17			
	24	36	0.7	123.97	30	36			2.4	99.50			
	23	36	0.7	129.62	28	38			2.2	107.20			
	22	36	0.7	139.13	26	41			2.0	115.07			
	20	36	0.7	149.90	24	44			1.9	123.97			
	18	36	0.7	168.84	23	46	1.8	129.62					
	17	36	0.7	181.24	22	50	1.7	139.13					
	15	36	0.7	195.26	20	54	1.6	149.90					
	13	36	0.7	236.09	18	60	1.4	168.84					
	9.8	36	0.7	307.54	17	65	1.3	181.24					
	579	2	3.8	5.18	NDP120/621	120/240	15	70	1.2	195.26			
	444	3	2.9	6.75			13	84	1.0	236.09			
	218	5	4.8	13.73	NDP120/622	120/240	9.8	110	0.8	307.54			
	189	6	4.1	15.88			32	33	3.6	92.70	NDP120/813	120/240	
	163	7	3.6	18.36			32	34	3.5	95.17			
	156	7	3.4	19.20			30	36	3.4	99.50			
	135	8	2.9	22.20			28	38	3.1	107.20			
	120	10	2.6	25.01			26	41	2.9	115.07			
	112	10	2.4	26.85			24	44	2.7	123.97			
	104	11	2.3	28.93			23	46	2.6	129.62			
	86	13	1.9	34.97			22	50	2.4	139.13			
	66	17	1.4	45.56			20	54	2.2	149.90			
							18	60	2.0	168.84			
							17	65	1.9	181.24			
							15	70	1.7	195.26			
							13	84	1.4	236.09			
					9.8	110	1.1	307.54					

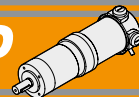

Dati tecnici per servizio S2

Technical data for S2 duty

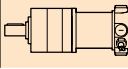
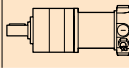
P_1 [W]	n_2 [min ⁻¹]	M_2 [Nm]	sf	i		Versione motore Motor version	P_1 [W]	n_2 [min ⁻¹]	M_2 [Nm]	sf	i		Versione motore Motor version		
250							250								
(3000 min ⁻¹)	811	2	1.7	3.70	NDP180/521	120/240	(3000 min ⁻¹)	59	28	1.8	50.89	NDP180/623	120/240		
	701	3	1.5	4.28				51	33	1.5	58.85				
	579	3	1.2	5.18				44	38	1.3	68.06				
	444	4	0.9	6.75				42	40	1.3	71.16				
								38	44	1.1	78.71				
	218	8	1.5	13.73	NDP180/522	120/240		32	52	1.0	92.70		120/240		
	189	10	1.3	15.88				32	53	0.9	95.17		120/240		
	163	11	1.1	18.36				30	56	0.9	99.50		120/240		
	156	12	1.0	19.20				28	60	0.8	107.20		120/240		
	135	13	0.9	22.20				26	64	0.8	115.07		120/240		
	120	15	0.8	25.01				24	69	0.7	123.97		120/240		
	112	16	0.7	26.85				23	71	0.7	129.62		120/240		
	104	17	0.7	28.93				22	71	0.7	139.13		120/240		
	86	17	0.7	34.97				20	71	0.7	149.90		120/240		
	66	17	0.7	45.56				18	71	0.7	168.84		120/240		
					NDP180/523	120/240		17	71	0.7	181.24		120/240		
	59	28	0.9	50.89				15	71	0.7	195.26		120/240		
	51	33	0.8	58.85				13	71	0.7	236.09		120/240		
	44	36	0.7	68.06				9.8	71	0.7	307.54		120/240		
	42	36	0.7	71.16											
	38	36	0.7	78.71				579	3	4.2	5.18	NDP180/721	120/240		
	32	36	0.7	92.70				444	4	3.2	6.75				
	32	36	0.7	95.17								NDP180/722	120/240		
	30	36	0.7	99.50				156	12	3.6	19.20				
	28	36	0.7	107.20				135	13	3.2	22.20				
	26	36	0.7	115.07		120	15	2.8	25.01						
	24	36	0.7	123.97		112	16	2.6	26.85						
	23	36	0.7	129.62		104	17	2.4	28.93						
	22	36	0.7	139.13		86	21	2.0	34.97						
	20	36	0.7	149.90		66	27	1.5	45.56						
	18	36	0.7	168.84						NDP180/723	120/240				
	17	36	0.7	181.24		59	28	2.9	50.89						
	15	36	0.7	195.26		51	33	2.5	58.85						
	13	36	0.7	236.09		44	38	2.2	68.06						
	9.8	36	0.7	307.54		42	40	2.1	71.16						
						38	44	1.9	78.71						
	811	2	3.4	3.70	NDP180/621	120/240		32	52			1.6	92.70		120/240
	701	3	2.9	4.28				32	53			1.6	95.17		120/240
	579	3	2.4	5.18				30	56			1.5	99.50		120/240
	444	4	1.9	6.75				28	60			1.4	107.20		120/240
	218	8	3.0	13.73	NDP180/622	120/240		26	64	1.3	115.07		120/240		
	189	10	2.6	15.88				24	69	1.2	123.97		120/240		
	163	11	2.3	18.36				23	73	1.2	129.62		120/240		
	156	12	2.2	19.20				22	78	1.1	139.13		120/240		
	135	13	1.9	22.20				20	84	1.0	149.90		120/240		
	120	15	1.7	25.01				18	95	0.9	168.84		120/240		
	112	16	1.6	26.85				17	101	0.8	181.24		120/240		
	104	17	1.4	28.93				15	109	0.8	195.26		120/240		
	86	21	1.2	34.97				13	120	0.7	236.09		120/240		
	66	27	0.9	45.56				9.8	120	0.7	307.54		120/240		
										NDP180/812	120/240				
						86	21	2.9	34.97						
						66	27	2.2	45.56		120/240				

NDP

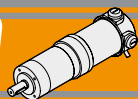

Dati tecnici per servizio S2

Technical data for S2 duty

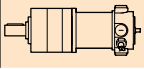
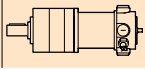
P_1 [W]	n_2 [min ⁻¹]	M_2 [Nm]	sf	i		Versione motore Motor version	P_1 [W]	n_2 [min ⁻¹]	M_2 [Nm]	sf	i		Versione motore Motor version		
250							250								
(3000 min ⁻¹)	44	38	3.1	68.06	NDP180/813	120/240	(3000 min ⁻¹)	32	52	3.8	92.70	NDP180/1053	120/240		
	42	40	3.0	71.16				32	53	3.7	95.17				
	38	44	2.7	78.71				30	56	3.5	99.50				
	32	52	2.3	92.70				28	60	3.2	107.20				
	32	53	2.3	95.17				26	64	3.0	115.07				
	30	56	2.2	99.50				24	69	2.8	123.97				
	28	60	2.0	107.20				23	73	2.7	129.62				
	26	64	1.9	115.07				22	78	2.5	139.13				
	24	69	1.7	123.97				20	84	2.3	149.90				
	23	73	1.7	129.62				18	95	2.1	168.84				
	22	78	1.5	139.13				17	101	1.9	181.24				
	20	84	1.4	149.90				15	109	1.8	195.26				
	18	95	1.3	168.84				13	132	1.5	236.09				
	17	101	1.2	181.24				9.8	172	1.1	307.54				
	15	109	1.1	195.26											
	13	132	0.9	236.09				18	95	3.2	168.84			NDP180/1203	120/240
	9.8	172	0.7	307.54				17	101	3.0	181.24				
						15	109	2.7	195.26						
						13	132	2.3	236.09						
						9.8	172	1.7	307.54						

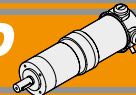

Dimensioni

Dimensions

NDP120/... U

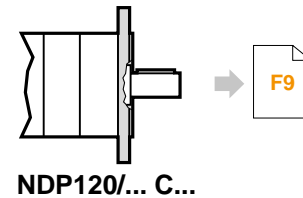
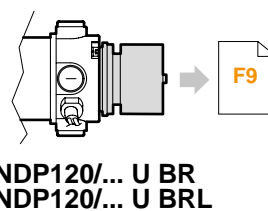
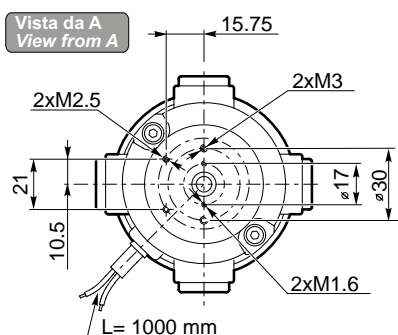
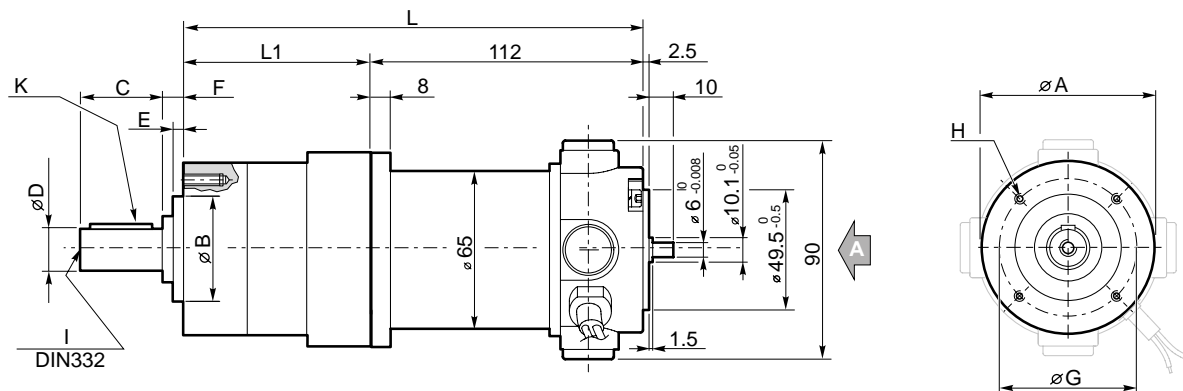

NDP

Tipo Type	Numero di stadi Stages number	Dimensioni / Dimensions											
		L1	L	A	B	C	D	E	F	G	H	I	K
NDP120/52...	1	74	186	52	32 h8	20.8	12 h7	3	4.2	40	M5x10	M4x10	4x4x16
	2	88	200										
	3	102	214										
NDP120/62...	1	74	186	62	40 j7	30	14 h7	5	9	52	M5x10	M5x12	5x5x18
	2	90	202										
	3	106	218										
NDP120/72...	1	82.4	194.4	72	45 j7	40	16 h7	5	9	60	M5x10	M5x12	5x5x30
	2	102	214										
	3	121.6	233.6										
NDP120/81...	1	91	203	81	50 j7	40	19 h7	5	9	65	M6x12	M6x16	6x6x28
	2	113	225										
	3	135	247										

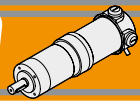

Dimensioni

Dimensions

NDP180/... U

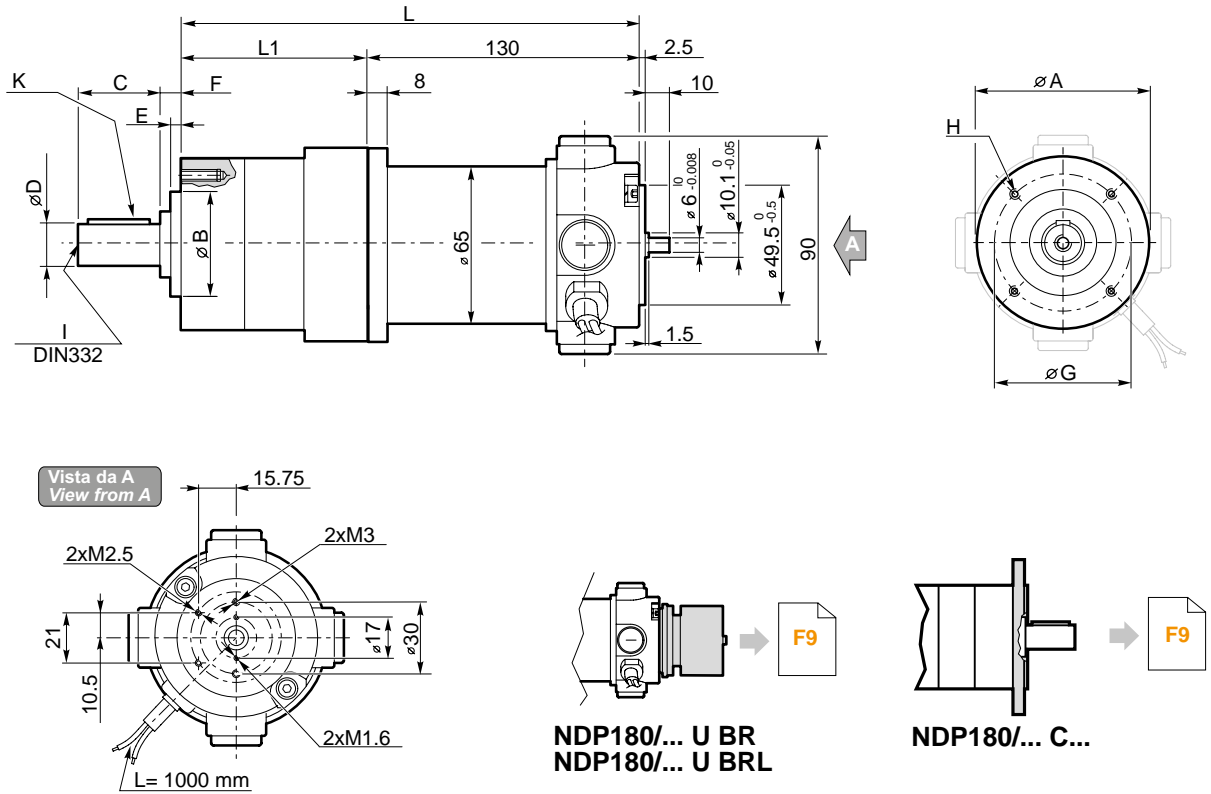

Tipo Type	Numero di stadi Stages number	Dimensioni / Dimensions											
		L1	L	A	B	C	D	E	F	G	H	I	K
NDP180/52	1	74	204	52	32 h8	20.8	12 h7	3	4.2	40	M5x10	M4x10	4x4x16
	2	88	218										
	3	102	232										
NDP180/62	1	74	204	62	40 j7	30	14 h7	5	9	52	M5x10	M5x12	5x5x18
	2	90	220										
	3	106	236										
NDP180/72	1	82.4	212.4	72	45 j7	40	16 h7	5	9	60	M5x10	M5x12	5x5x30
	2	102	232										
	3	121.6	251.6										
NDP180/81	1	91	203	81	50 j7	40	19 h7	5	9	65	M6x12	M6x16	6x6x28
	2	113	225										
	3	135	247										
NDP180105	1	113.4	243.4	105	70 j7	50	25 h7	5	9	85	M8x16	M10x22	8x7x40
	2	144.5	274.5										
	3	175.5	305.5										
NDP180/120	1	131.6	261.6	120	80 j7	73	32 k6	5	15	100	M10x22	M12	10x8x50
	2	165.8	295.8										
	3	200	330										

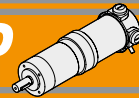

Dimensioni

Dimensions

NDP../... C... Flange uscita / Output flanges

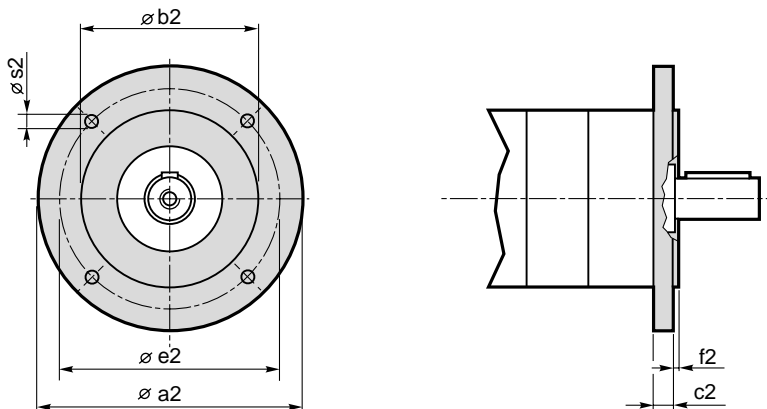

Dimensioni / Dimensions							
P	a2	b2	c2	e2	f2	s2	Flangia uscita Output flange
52	80	50 j7	9	65	2.5	M5	C80
	90	60 j7	9	75	2.5	5.5	C90
	105	70 j7	9	85	2.5	6.5	C105
	120	80 j7	9	100	3.0	6.5	C120
62	80	50 j7	9	65	2.5	M5	C80
	90	60 j7	9	75	2.5	5.5	C90
	105	70 j7	9	85	2.5	6.5	C105
	120	80 j7	9	100	3.0	6.5	C120
72	80	50 j7	9	65	2.5	M5	C80
	90	60 j7	9	75	2.5	M5	C90
	105	70 j7	9	85	2.5	6.5	C105
	120	80 j7	9	100	3.0	6.5	C120
81	90	60 j7	9	75	2.5	M5	C90
	105	70 j7	9	85	2.5	M6	C105
	120	80 j7	9	100	3.0	6.5	C120
P105	120	80 j7	12	100	3	M6	C120
	140	95 j7	12	115	3.5	M8	C140
	160	110 j7	12	130	3.5	M8	C160
P120	140	95 j7	15	115	3	M8	C140
	160	110 j7	15	130	3.5	M8	C160

NDP

NDP../... U BR Freno / Brake

NDP../... U BRL Freno con leva di sblocco/ Brake with hand release

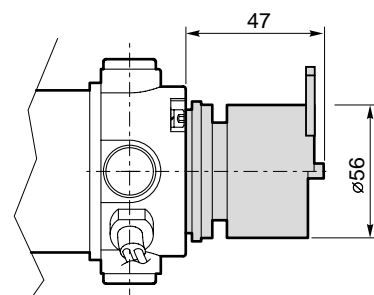
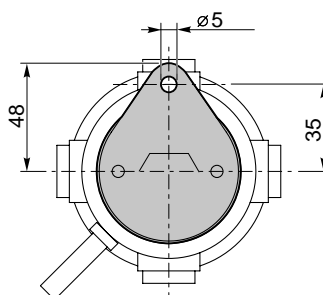
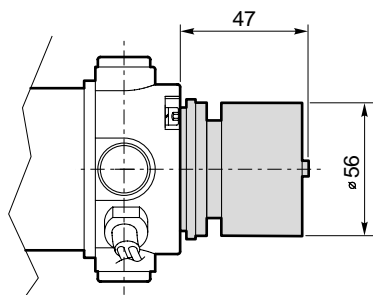

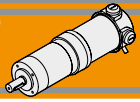

NDP

MOTORIDUTTORI CC EPICICLOIDALI A MAGNETI PERMANENTI IN NEODIMIO
NEODYMIUM PERMANENT MAGNETS DC PLANETARY GEARMOTORS

Note/Notes

TRANSTECNO[®]
the modular gearmotor

NDWMP



NDWMP

Motoriduttori CC combinati
a magneti permanenti in neodimio
Neodymium permanent magnets
DC double reduction gearmotors



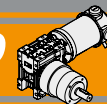

Indice	Index	Pag. Page
Caratteristiche tecniche	<i>Technical features</i>	G2
Designazione	<i>Classification</i>	G2
Versioni	<i>Versions</i>	G2
Simbologia	<i>Symbols</i>	G2
Lubrificazione	<i>Lubrication</i>	G3
Carichi radiali	<i>Radial loads</i>	G3
Rapporti	<i>Ratios</i>	G4
Dati tecnici	<i>Technical data</i>	G5
Dimensioni	<i>Dimensions</i>	G6
Note	<i>Notes</i>	G10

Questa sezione annulla e sostituisce ogni precedente edizione o revisione. Qualora questa sezione non Vi sia giunta in distribuzione controllata, l'aggiornamento dei dati ivi contenuto non è assicurato. **In tal caso la versione più aggiornata è disponibile sul nostro sito internet www.transtecno.com**

*This section replaces any previous edition and revision. If you obtained this catalogue other than through controlled distribution channels, the most up to date content is not guaranteed. **In this case the latest version is available on our web site www.transtecno.com***

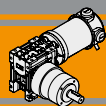

Caratteristiche tecniche

Technical features

L'accoppiamento di un riduttore a vite senza fine con un riduttore epicicloidale consente di ottenere elevati rapporti di riduzione ($i_{max} = 1/18452$) e di disporre di un gruppo autolubrificato compatto, silenzioso e con un'elevata affidabilità.

The coupling of a wormgearbox to a planetary gearbox allows to obtain high reduction ratios ($i_{max} = 1/18452$) and to get a compact, silent, self lubricated with high reliability group.

Designazione

Classification

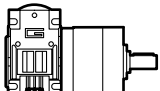
MOTORIDUTTORE / GEARMOTOR									
NDWMP	120/026/52		2	CD	90	405	240	BR	
Tipo Type	Grandezza Size		Numero stadi epicicloidale Planetary stages number	Versione Riduttore Gearbox Version	Flangia Uscita Output flange	Rapporto Ratio	Versione Motore Motor Version	Opzioni Options	
	NDWMP	120/026/52	180/026/62	1	US	Vedere tabella See tables	120	BR BRL	
		120/026/62	180/030/81	2	UD		90		240
		120/030/81		3	CS CD		105 120		

Versioni

Versions

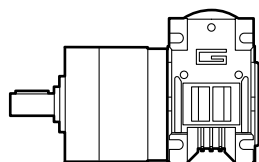

US

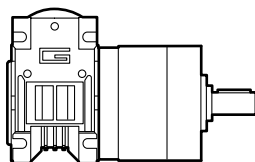

UD

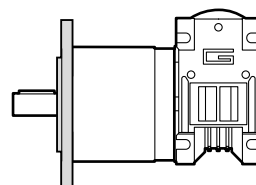

CS

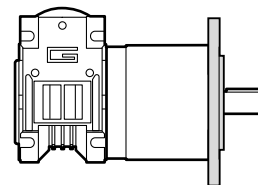

CD

Simbologia

Symbols

n_1	[min ⁻¹]	Velocità in ingresso / <i>Input speed</i>
n_2	[min ⁻¹]	Velocità in uscita / <i>Output speed</i>
i		Rapporto di riduzione / <i>Ratio</i>
P_1	[kW]	Potenza in entrata / <i>Input power</i>
M_n	[Nm]	Coppia nominale in uscita del riduttore / <i>Maximum output torque of the gearbox</i>
M_2	[Nm]	Coppia in uscita in funzione di P_1 / <i>Output torque referred to P_1</i>
sf		Fattore di servizio / <i>Service factor</i>
R_d	%	Rendimento dinamico / <i>Dynamic efficiency</i>
A_2	[N]	Carico assiale ammissibile in uscita / <i>Permitted output axial load</i>
R_2	[N]	Carico radiale ammissibile in uscita / <i>Permitted output radial load</i>

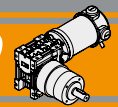

Lubrificazione

Lubrication

I riduttori a vite senza fine della serie CM sono lubrificati a vita con olio sintetico di viscosità 320 e possono essere installati in qualunque posizione di montaggio.

Permanent synthetic oil long-life lubrication allow to use CM wormgearbox range in all mounting position.

I riduttori epicicloidali sono lubrificati in modo permanente, non richiedono quindi ulteriore manutenzione. Questo gli consente di essere installati praticamente ovunque.

Planetary gearboxes are life-time lubricated with grease, therefore they are maintenance free. They can be installed in any location.

Carichi radiali

Radial loads

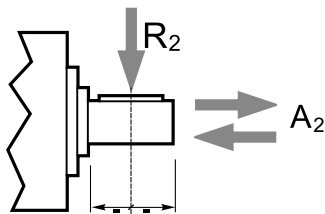

Numero di stadi Stages number	Carichi Radiali R_2 [N] Radial Load R_2 [N]		
	P52	P62	P81
1	200	240	400
2	320	360	600
3	450	520	1000

Numero di stadi Stages number	Carichi Assiali A_2 [N] Axial Load A_2 [N]		
	P52	P62	P81
1	60	70	80
2	100	100	120
3	150	150	200

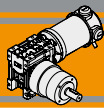

Rapporti

Ratios

Motoriduttore Gearmotor	Numero stadi epicicloidale Planetary stages number	Rapporto epicicloidale Planetary ratio	Rapporto vite senza fine Wormgearbox ratio	Rapporto finale Total ratio
.../026/52 .../026/62 .../030/81	1	6.75	10	67.5
			15	101.3
			20	135
			30	202.5
			40	270
			50	337.5
			60	405
	2	28.93	10	289.3
			15	434.0
			20	578.6
			30	867.9
			40	1157
			50	1447
			60	1736
	34.97	60	2098	
	45.56	60	2734	

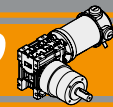

Dati tecnici per servizio S2

Technical data for S2 duty

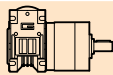
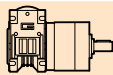
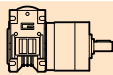
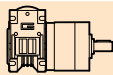
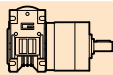
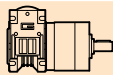
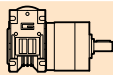
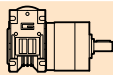
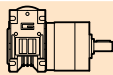
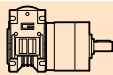
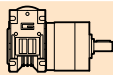
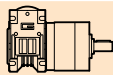
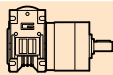
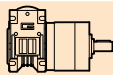
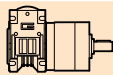
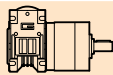
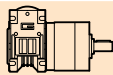
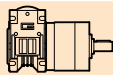
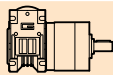
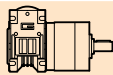
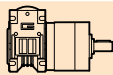
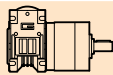
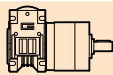
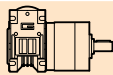
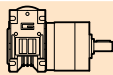
P_1 [W]	n_2 [min ⁻¹]	M_2 [Nm]	sf	i		Versione motore Motor version
160						
(3000 min ⁻¹)	44.4	23	1.1	67.5		120/026/521
	29.6	25	1.0	101.3		
	22.2	25	1.0	135.0		
	14.8	25	1.0	202.5		
	11.1	25	1.0	270.0		
	10.4	25	1.0	289.3		120/026/522
	8.9	25	1.0	337.5		120/026/521
	7.4	25	1.0	405.0		120/026/521
	6.9	25	1.0	434.0		120/026/522
	5.2	25	1.0	578.6		120/026/522
	3.5	25	1.0	867.9		120/026/522
	2.6	25	1.0	1157.0		120/026/522
	2.1	25	1.0	1447.0		120/026/522
	1.7	25	1.0	1736.0		120/026/522
	1.4	25	1.0	2098.0		120/026/522
	1.1	25	1.0	2734.0		120/026/522
	44.4	23	1.7	67.5		120/026/621
	29.6	34	1.2	101.3		
	22.2	40	1.0	135.0		
	14.8	40	1.0	202.5		
	11.1	40	1.0	270.0		
	10.4	50	1.0	289.3		120/026/622
	8.9	40	1.0	337.5		120/026/621
	7.4	40	1.0	405.0		120/026/621
	6.9	50	1.0	434.0		120/026/622
	5.2	50	1.0	578.6		120/026/622
	3.5	50	1.0	867.9		120/026/622
	2.6	50	1.0	1157.0		120/026/622
	2.1	50	1.0	1447.0		120/026/622
	1.7	50	1.0	1736.0		120/026/622
	1.4	50	1.0	2098.0		120/026/622
	1.1	50	1.0	2734.0		120/026/622

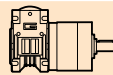
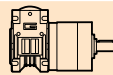
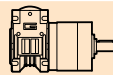
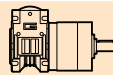
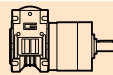
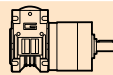
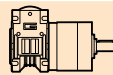
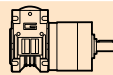
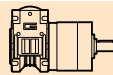
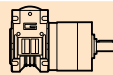
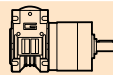
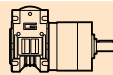
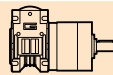
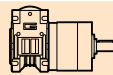
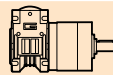
P_1 [W]	n_2 [min ⁻¹]	M_2 [Nm]	sf	i		Versione motore Motor version
160						
(3000 min ⁻¹)	44.4	24	3.4	67.5		120/030/811
	29.6	35	2.3	101.3		
	22.2	45	1.8	135.0		
	14.8	61	1.3	202.5		
	11.1	77	1.0	270.0		
	10.4	95	1.3	289.3		120/030/812
	8.9	80	1.0	337.5		120/030/811
	7.4	80	1.0	405.0		120/030/811
	6.9	120	1.0	434.0		120/030/812
	5.2	120	1.0	578.6		120/030/812
	3.5	120	1.0	867.9		120/030/812
	2.6	120	1.0	1157.0		120/030/812
	2.1	120	1.0	1447.0		120/030/812
	1.7	120	1.0	1736.0		120/030/812
	1.4	120	1.0	2098.0		120/030/812
	1.1	120	1.0	2734.0		120/030/812
250						
(3000 min ⁻¹)	44.4	37	1.1	67.5		180/026/621
	44.4	40	2.0	67.5		
	29.6	54	1.5	101.3		
	22.2	70	1.1	135.0		
	14.8	80	1.0	202.5		
	10.4	120	1.0	289.3		180/030/812

Nota: Verificare sempre che la coppia M_2 utilizzata non ecceda il valore indicato nelle caselle in grigio
Note: Please check that the output torque M_2 does not exceed the value into the grey areas

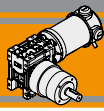

Dimensioni

Dimensions

NDWMP120/026/52...U

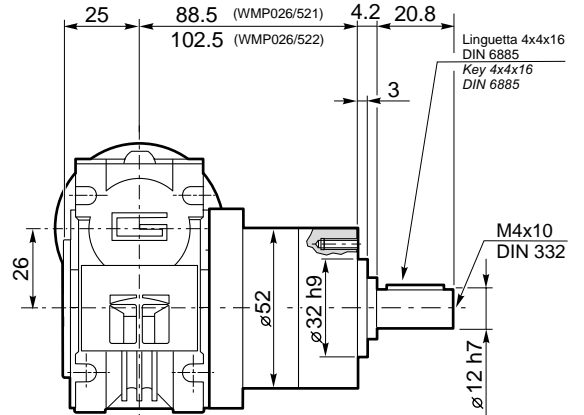
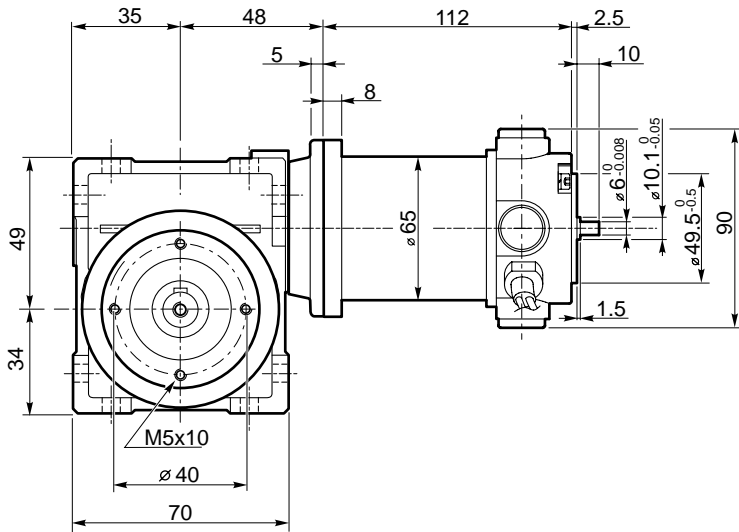

Vista da A
View from A

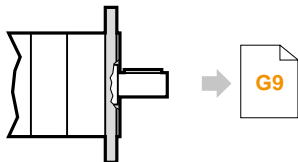
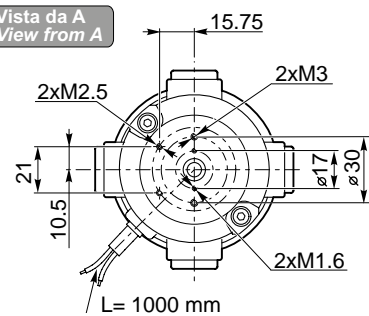

NDWMP120/026/52...C

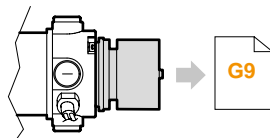

**NDWMP120/026/52...U BR
NDWMP120/026/52...U BRL**

NDWMP120/026/62...U

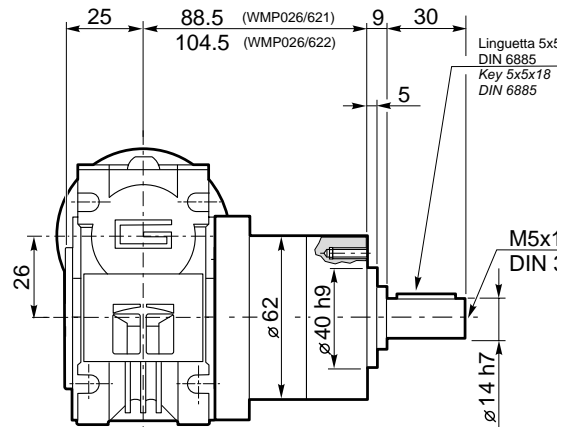
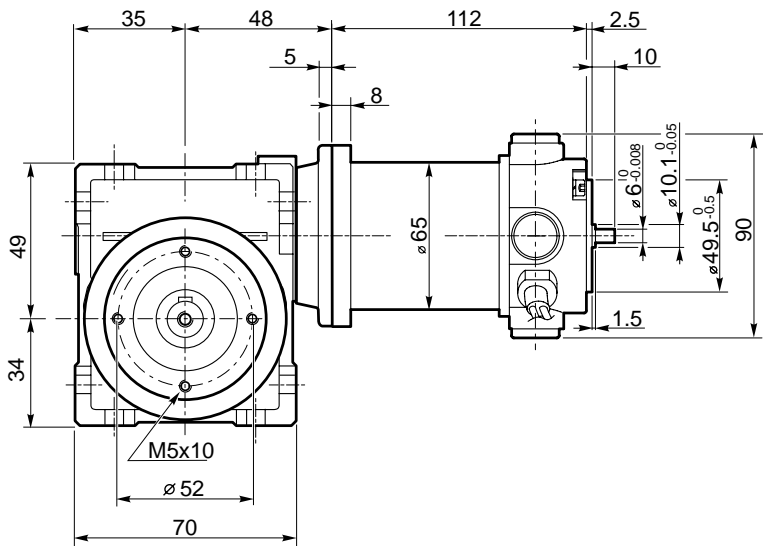

Vista da A
View from A

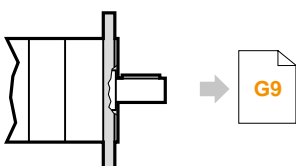
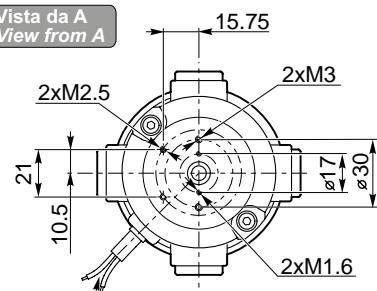

NDWMP120/026/62...C

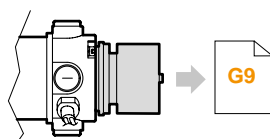

**NDWMP120/026/62...U BR
NDWMP120/026/62...U BRL**

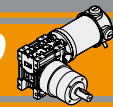

Dimensioni

Dimensions

NDWMP120/030/81...U

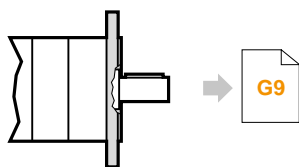
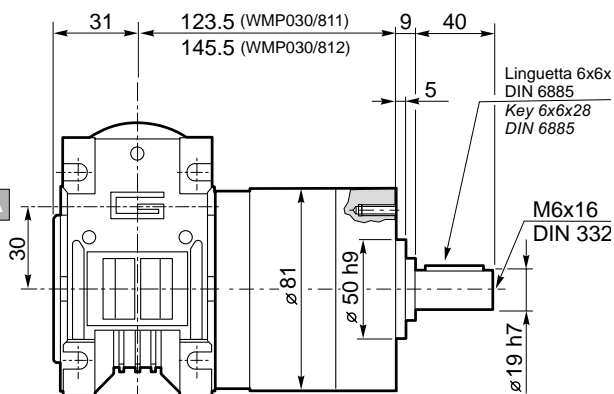
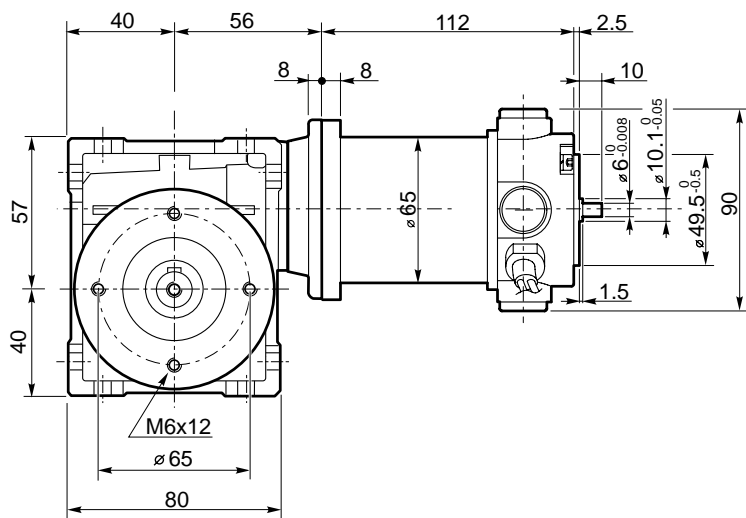

NDWMP120/030/81...C

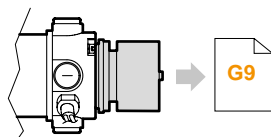

NDWMP120/030/81...U BR
NDWMP120/030/81...U BRL

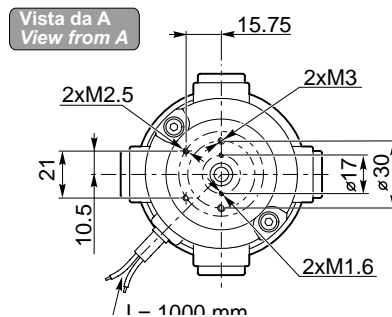

NDWMP

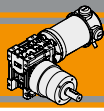

Dimensioni

Dimensions

NDWMP180/026/62...U

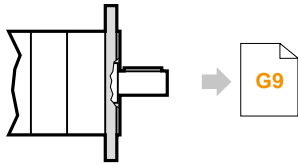
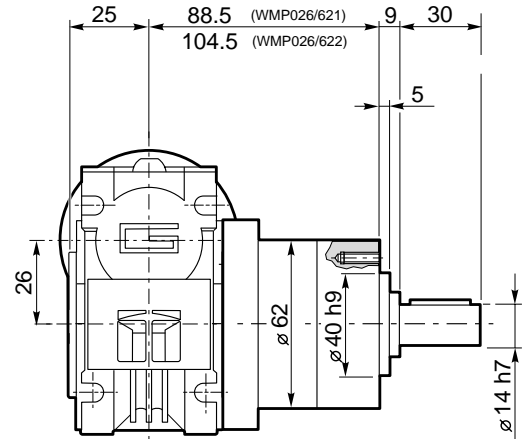
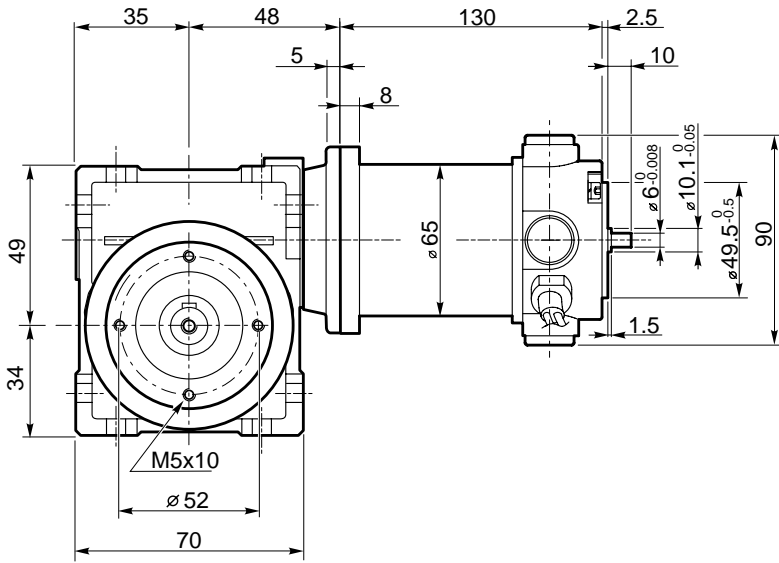

NDWMP180/026/62...C

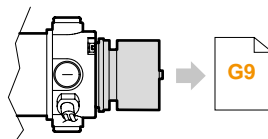

NDWMP180/026/62...U BR
NDWMP180/026/62...U BRL

Vista da A
View from A

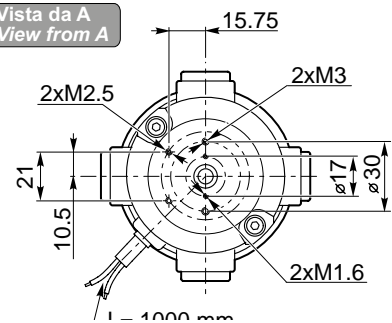

NDWMP180/030/81...U

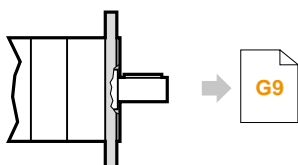
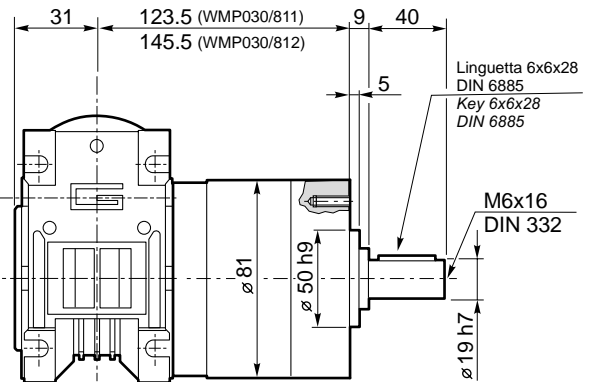
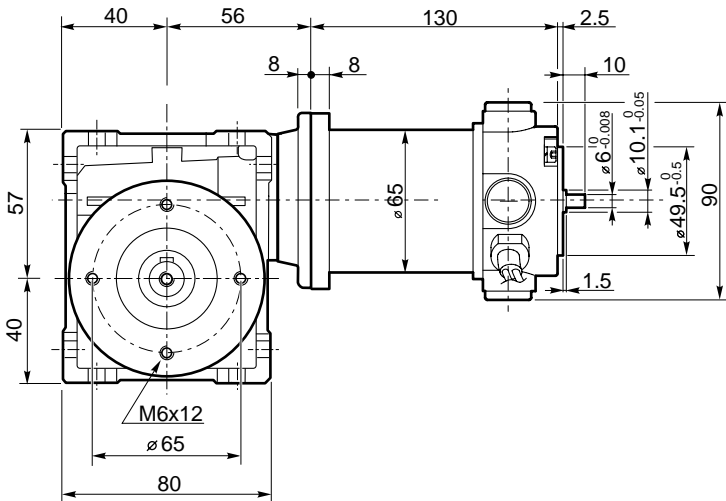

NDWMP180/030/81...C

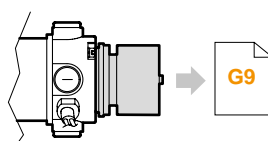

NDWMP180/030/81...U BR
NDWMP180/030/81...U BRL

Vista da A
View from A

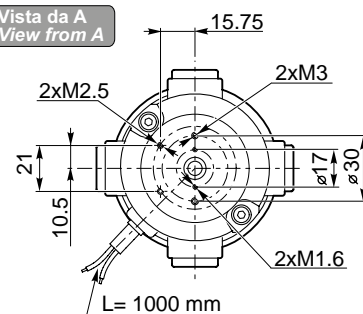

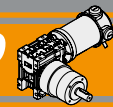

Dimensioni

Dimensions

NDWMP.../.../... C... Flange uscita / Output flanges

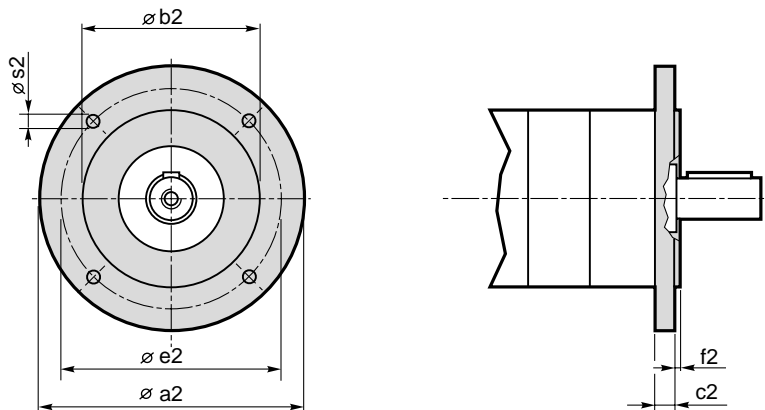

Dimensioni / Dimensions							
P	a2	b2	c2	e2	f2	s2	Flangia uscita Output flange
52	80	50 j7	9	65	2.5	M5	C80
	90	60 j7	9	75	2.5	5.5	C90
	105	70 j7	9	85	2.5	6.5	C105
	120	80 j7	9	100	3.0	6.5	C120
62	80	50 j7	9	65	2.5	M5	C80
	90	60 j7	9	75	2.5	5.5	C90
	105	70 j7	9	85	2.5	6.5	C105
	120	80 j7	9	100	3.0	6.5	C120
81	90	60 j7	9	75	2.5	M5	C90
	105	70 j7	9	85	2.5	M6	C105
	120	80 j7	9	100	3.0	6.5	C120

NDWMP

NDP.../... U BR Freno / Brake

NDP.../... U BRL Freno con leva di sblocco / Brake with hand release

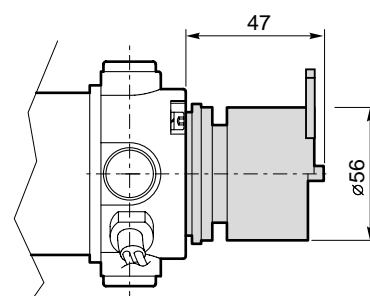
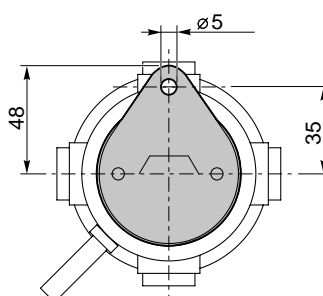
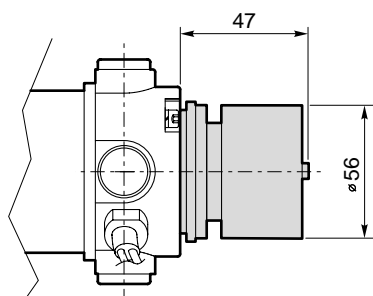

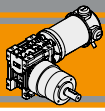

Note/Notes

TRANSTECNO[®]
the modular gearmotor

ECP



Small but Strong

ECP

Motoriduttori CC epicicloidali
a magneti permanenti in ferrite
**Ferrite permanent magnets DC
planetary gearmotors**



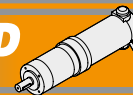

Indice	Index	Pag. Page
Caratteristiche tecniche	<i>Technical features</i>	H2
Designazione	<i>Classification</i>	H2
Versioni	<i>Versions</i>	H2
Simbologia	<i>Symbols</i>	H2
Lubrificazione	<i>Lubrication</i>	H2
Carichi radiali	<i>Radial loads</i>	H3
Rapporti	<i>Ratios</i>	H3
Dati tecnici	<i>Technical data</i>	H4
Motori applicabili	<i>IEC Motor adapters</i>	H11
Dimensioni	<i>Dimensions</i>	H12

Questa sezione annulla e sostituisce ogni precedente edizione o revisione. Qualora questa sezione non Vi sia giunta in distribuzione controllata, l'aggiornamento dei dati ivi contenuto non è assicurato. **In tal caso la versione più aggiornata è disponibile sul nostro sito internet www.transtecno.com**

This section replaces any previous edition and revision. If you obtained this catalogue other than through controlled distribution channels, the most up to date content is not guaranteed. In this case the latest version is available on our web site www.transtecno.com

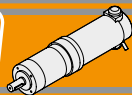
**ECP****MOTORIDUTTORI CC EPICICLOIDALI A MAGNETI PERMANENTI IN FERRITE**
FERRITE PERMANENT MAGNETS DC PLANETARY GEARMOTORS**Caratteristiche tecniche****Technical features**

Le caratteristiche principali dei motoriduttori CC epicicloidali a magneti permanenti in ferrite serie ECP sono:

The main features of ECP Ferrite permanent magnets DC planetary gearmotors range are:

- Alimentazione in bassa tensione 12/24 Vcc
- Possibilità di montaggio encoder
- Potenze motore disponibili da 30 a 800W S2
- Magneti in ferrite
- Entrata ed uscita coassiali
- Design compatto
- Lubrificazione permanente a grasso
- Possono essere installati in qualunque posizione di montaggio.

- Low voltage power supply 12/24 Vdc
- Suitable for encoder assembly
- Motor power ratings available from 30 up to 800W S2
- Ferrite magnets
- Coaxial arrangement of the input and output
- Compact design
- Permanent grease oil long-life lubrication
- Can be intalled in all mounting position.

Designazione**Classification**

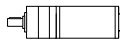
MOTORIDUTTORE / GEARMOTOR										2	C	90	34.97	120	BR
ECP	070/62									Stadi riduttore Gearbox stages	Versione riduttore Gearbox Version	Flangia Uscita Output flange	Rapporto Ratio	Versione Motore Motor Version	Opzioni Options
Tipo Type	Grandezza Size														
	020/42	035/42	050/42	070/52	100/52	180/52	250/62	350/62	600/72	1	U	80	Vedere tabella See tables	120	BR
		035/52	050/52	070/62	100/62	180/62	250/72	350/72	600/81	2	C	90		240	BRL
				070/72	100/72	180/72	250/81	350/81	600/105	3		105			
				070/81	100/81	180/81	250/105	350/105	600/120			120			24E
						180/105	250/120	350/120							
						180/120									

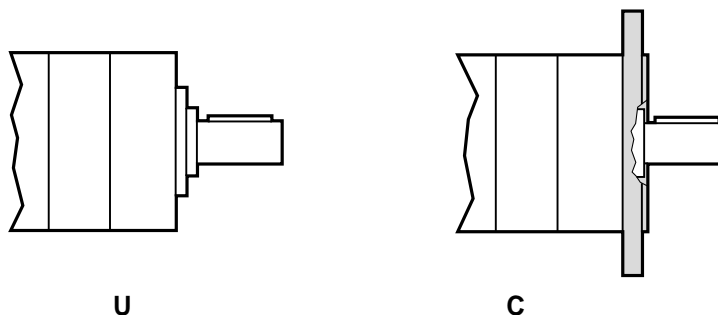
Versioni**Versions****Simbologia****Symbols**

n_1 [min ⁻¹]	Velocità in ingresso / Input speed	sf	Fattore di servizio / Service factor
n_2 [min ⁻¹]	Velocità in uscita / Output speed	Rd %	Rendimento dinamico / Dynamic efficiency
i	Rapporto di riduzione / Ratio	A ₂ [N]	Carico assiale ammissibile in uscita / Permitted output axial load
P ₁ [kW]	Potenza in entrata / Input power	R ₂ [N]	Carico radiale ammissibile in uscita / Permitted output radial load
M ₂ [Nm]	Coppia in uscita in funzione di P ₁ / Output torque referred to P ₁		

Lubrificazione**Lubrication**

I riduttori epicicloidali sono lubrificati in modo permanente, non richiedono quindi ulteriore manutenzione. Questo gli consente di essere installati praticamente ovunque.

Planetary gearboxes are life-time lubricated with grease, therefore they are maintenance free. They can be installed in any location.

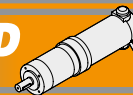

Carichi radiali

Radial loads

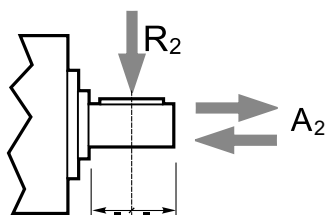

Numero di stadi Stages number	Carichi Radiali R_2 [N] / Radial Load R_2 [N]						
	P42	P52	P62	P72	P81	P105	P120
1	160	200	240	320	400	600	600
2	230	320	360	480	600	900	900
3	300	450	520	760	1000	1500	1500

Numero di stadi Stages number	Carichi Assiali A_2 [N] / Axial Load A_2 [N]						
	P42	P52	P62	P72	P81	P105	P120
1	50	60	70	70	80	120	120
2	80	100	100	100	120	180	180
3	110	150	150	160	200	300	300

Rapporti

Ratios

Numero di stadi Stages number	Per tutte le grandezze di riduttori della serie P For all gearbox sizes of P range
	Rapporti / Ratios
1	3.70
	4.28*
	5.18*
	6.75
2	13.73
	15.88*
	18.36*
	19.20*
	22.20*
	25.01
	26.85*
	28.93*
	34.97*
45.56	
3	50.89
	58.85*
	68.06*
	71.16*
	78.71*
	92.70
	95.17*
	99.50*
	107.20*
	115.07*
	123.97*
	129.62*
	139.13*
	149.90*
	168.84
181.24*	
195.26*	
236.09*	
307.54	



Rapporti preferenziali
Preferred ratios

* Rapporto non disponibile su grandezza P120
Ratio not available on size P120

Disponibile a 4 stadi con rapporti fino a 2076
Available 4 stages with ratio up to 2076





ECP

MOTORIDUTTORI CC EPICICLOIDALI A MAGNETI PERMANENTI IN FERRITE
FERRITE PERMANENT MAGNETS DC PLANETARY GEARMOTORS

Dati tecnici per servizio S2

Technical data for S2 duty

P ₁ [W]	n ₂ [min ⁻¹]	M ₂ [Nm]	sf	i		Versione motore Motor version	P ₁ [W]	n ₂ [min ⁻¹]	M ₂ [Nm]	sf	i		Versione motore Motor version			
30							55									
(2850 min ⁻¹)	770	0.24	12.7	3.70	ECP020/421	120/24E	(2850 min ⁻¹)	31	12	1.3	95.17	ECP035/423	120/240			
	666	0.27	11.0	4.28				30	13	1.2	99.50					
	550	0.33	9.0	5.18				28	14	1.1	107.20					
	422	0.43	6.9	6.75				26	14	1.0	115.07					
	208	0.82	9.1	13.73	ECP020/422	120/24E		24	16	1.0	123.97					
	179	0.95	7.9	15.88				23	16	0.9	129.62					
	155	1.1	6.8	18.36				22	18	0.9	139.13					
	148	1.2	6.5	19.20				20	19	0.8	149.90					
	128	1.3	5.6	22.20				18	21	0.7	168.84					
	114	1.5	5.0	25.01				17	21	0.7	181.24					
	106	1.6	4.7	26.85				15	21	0.7	195.26					
	99	1.7	4.3	28.93				13	21	0.7	236.09					
	81	2.1	3.6	34.97				10	21	0.7	307.54					
	63	2.7	2.7	45.56												
	56	2.8	5.3	50.89			ECP020/423	120/24E		811	0.53	7.5	3.70	ECP035/521	120/240	
	48	3.3	4.6	58.85						701	0.62	6.5	4.28			
	42	3.8	3.9	68.06						579	0.75	5.4	5.18			
	40	4.0	3.8	71.16						444	0.97	4.1	6.75			
	36	4.4	3.4	78.71												
	31	5.2	2.9	92.70						218	1.9	6.5	13.73	ECP035/522	120/240	
	30	5.3	2.8	95.17		189			2.1	5.6	15.88					
	29	5.6	2.7	99.50		163			2.5	4.8	18.36					
	27	6.0	2.5	107.20		156			2.6	4.6	19.20					
	25	6.4	2.3	115.07		135			3.0	4.0	22.20					
	23	6.9	2.2	123.97		120			3.4	3.6	25.01					
	22	7.3	2.1	129.62		112			3.6	3.3	26.85					
	20	7.8	1.9	139.13		104			3.9	3.1	28.93					
	19	8.4	1.8	149.90		86			4.7	2.5	34.97					
	17	9.5	1.6	168.84		66			6.2	2.0	45.56					
	16	10	1.5	181.24												
	15	11	1.4	195.26		59	6.4	3.9	50.89	ECP035/523	120/240					
	12	13	1.1	236.09		51	7.4	3.4	58.85							
	9.3	17	0.9	307.54		44	8.6	2.9	68.06							
						42	9.0	2.8	71.16							
						38	9.9	2.5	78.71							
						32	11.7	2.1	92.70							
						31	12.0	2.1	95.17							
						30	12.5	2.0	99.50							
						28	13.5	1.9	107.20							
						26	14.5	1.7	115.07							
						24	15.6	1.6	123.97							
						23	16.3	1.5	129.62							
						22	17.5	1.4	139.13							
						20	18.9	1.3	149.90							
						18	21.3	1.2	168.84							
						17	22.8	1.1	181.24							
						15	24.6	1.0	195.26							
						13	29.7	0.8	236.09							
						10	35.7	0.7	307.54							
55							70									
(3000 min ⁻¹)	811	0.53	5.6	3.70	ECP035/421	120/240	(3000 min ⁻¹)	811	0.65	4.6	3.70	ECP050/421	12E/24E			
	701	0.62	4.9	4.28				701	0.75	4.0	4.28					
	579	0.75	4.0	5.18				579	0.91	3.3	5.18					
	444	0.97	3.1	6.75				444	1.2	2.5	6.75					
	218	1.9	4.0	13.73	ECP035/422	120/240		218	2.3	3.3	13.73	ECP050/422	12E/24E			
	189	2.1	3.5	15.88				189	2.6	2.9	15.88					
	163	2.5	3.0	18.36				163	3.0	2.5	18.36					
	156	2.6	2.9	19.20				156	3.2	2.4	19.20					
	135	3.0	2.5	22.20				135	3.7	2.0	22.20					
	120	3.4	2.2	25.01				120	4.1	1.8	25.01					
	112	3.6	2.1	26.85				112	4.4	1.7	26.85					
	104	3.9	1.9	28.93				104	4.8	1.6	28.93					
	86	4.7	1.6	34.97				86	5.8	1.3	34.97					
	65.8	6.2	1.2	45.56				66	7.5	1.0	45.56					
	59	6.4	2.3	50.89			ECP035/423	120/240								
	51	7.4	2.0	58.85												
	44	8.6	1.7	68.06												
	42	9.0	1.7	71.16												
	38	9.9	1.5	78.71												
	32	12	1.3	92.70												

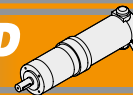

Dati tecnici per servizio S2

Technical data for S2 duty

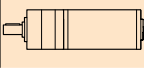
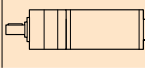
P_1 [W]	n_2 [min ⁻¹]	M_2 [Nm]	sf	i		Versione motore Motor version	P_1 [W]	n_2 [min ⁻¹]	M_2 [Nm]	sf	i		Versione motore Motor version
70							100						
(2850 min ⁻¹)	59	7.8	1.9	50.89	ECP050/423	12E/24E	(3000 min ⁻¹)	59	11	2.3	50.89	ECP070/523	120/240
	51	9.1	1.7	58.85				51	13	2.0	58.85		
	44	10	1.4	68.06				44	15	1.7	68.06		
	42	11	1.4	71.16				42	15	1.6	71.16		
	38	12	1.2	78.71				38	17	1.5	78.71		
	32	14	1.1	92.70				32	20	1.2	92.70		
	31	15	1.0	95.17				31	21	1.2	95.17		
	30	15	1.0	99.50				30	22	1.2	99.50		
	28	17	0.9	107.20				28	23	1.1	107.20		
	26	18	0.8	115.07				26	25	1.0	115.07		
	24	19	0.8	123.97				24	27	0.9	123.97		
	23	20	0.8	129.62				23	28	0.9	129.62		
	22	21	0.7	139.13				22	30	0.8	139.13		
	20	21	0.7	149.90				20	33	0.8	149.90		
	18	21	0.7	168.84				18	36	0.7	168.84		
	17	21	0.7	181.24				17	36	0.7	181.24		
	15	21	0.7	195.26				15	36	0.7	195.26		
	13	21	0.7	236.09				13	36	0.7	236.09		
	9.8	21	0.7	307.54				9.8	36	0.7	307.54		
	163	3.0	4.0	18.36	ECP050/522	12E/24E		120.0	5.8	4.3	25.01	ECP070/622	120/240
	156	3.2	3.8	19.20				112	6.2	4.0	26.85		
	135	3.7	3.3	22.20				104	6.7	3.7	28.93		
	120	4.1	2.9	25.01				86	8.1	3.1	34.97		
	112	4.4	2.7	26.85				66	11	2.4	45.56		
	104	4.8	2.5	28.93				59	11	4.5	50.89	ECP070/623	120/240
	86	5.8	2.1	34.97				51	13	3.9	58.85		
	66	7.5	1.6	45.56				44	15	3.4	68.06		
	59	7.8	3.2	50.89	ECP050/523	12E/24E		42	15	3.2	71.16		
	51	9.1	2.8	58.85				38	17	2.9	78.71		
	44	10	2.4	68.06				32	20	2.5	92.70		
	42	11	2.3	71.16				31	21	2.4	95.17		
	38	12	2.1	78.71				30	22	2.3	99.50		
	32	14	1.8	92.70				28	23	2.1	107.20		
	31	15	1.7	95.17				26	25	2.0	115.07		
	30	15	1.6	99.50				24	27	1.9	123.97		
	28	17	1.5	107.20				23	28	1.8	129.62		
	26	18	1.4	115.07				22	30	1.7	139.13		
	24	19	1.3	123.97				20	33	1.5	149.90		
	23	20	1.3	129.62				18	37	1.4	168.84		
	22	21	1.2	139.13				17	39	1.3	181.24		
	20	23	1.1	149.90				15	42	1.2	195.26		
	18	26	1.0	168.84				13	51	1.0	236.09		
	17	28	0.9	181.24				9.8	67	0.7	307.54		
	15	30	0.8	195.26				32	20	4.2	92.70	ECP070/723	120/240
	13	36	0.7	236.09				31	21	4.1	95.17		
	9.8	36	0.7	307.54				30	22	3.9	99.50		
								28	23	3.6	107.20		
								26	25	3.4	115.07		
								24	27	3.1	123.97		
								23	28	3.0	129.62		
								22	30	2.8	139.13		
								20	33	2.6	149.90		
								18	37	2.3	168.84		
								17	39	2.1	181.24		
								15	42	2.0	195.26		
								13	51	1.6	236.09		
								9.8	67	1.3	307.54		
100							100						
(3000 min ⁻¹)	811	0.92	4.4	3.70	ECP070/521	120/240							
	701	1.1	3.8	4.28									
	579	1.3	3.1	5.18									
	444	1.7	2.4	6.75									
	218	3.2	3.8	13.73	ECP070/522	120/240							
	189	3.7	3.3	15.88									
	163	4.3	2.8	18.36									
	156	4.5	2.7	19.20									
	135	5.2	2.3	22.20									
	120	5.8	2.1	25.01									
	112	6.2	1.9	26.85									
	104	6.7	1.8	28.93									
	86	8.1	1.5	34.97									
	66	11	1.1	45.56									

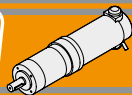
**ECP****MOTORIDUTTORI CC EPICICLOIDALI A MAGNETI PERMANENTI IN FERRITE**
FERRITE PERMANENT MAGNETS DC PLANETARY GEARMOTORS**Dati tecnici per servizio S2****Technical data for S2 duty**

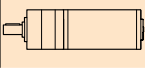
P ₁ [W]	n ₂ [min ⁻¹]	M ₂ [Nm]	sf	i		Versione motore Motor version
100						
(3000 min ⁻¹)	20	33	3.7	149.90	ECP070/813	120/240
	18	37	3.3	168.84		
	17	39	3.1	181.24		
	15	42	2.8	195.26		
	13	51	2.3	236.09		
	9.8	67	1.8	307.54		

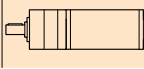
P ₁ [W]	n ₂ [min ⁻¹]	M ₂ [Nm]	sf	i		Versione motore Motor version
140						
(3000 min ⁻¹)	59	15	3.3	50.89	ECP100/623	120/240/24E
	51	18	2.8	58.85		
	44	20	2.4	68.06		
	42	21	2.3	71.16		
	38	24	2.1	78.71		
	32	28	1.8	92.70		
	31	29	1.7	95.17		
	30	30	1.7	99.50		
	28	32	1.5	107.20		
	26	35	1.4	115.07		
	24	37	1.3	123.97		
	23	39	1.3	129.62		
	22	42	1.2	139.13		
	20	45	1.1	149.90		
	18	51	1.0	168.84		
	17	55	0.9	181.24		
	15	59	0.9	195.26		
	13	71	0.7	236.09		
	9.8	71	0.7	307.54		

140								
(3000 min ⁻¹)	811	1.3	3.1	3.70	ECP100/521	120/240/24E		
	701	1.5	2.7	4.28				
	579	1.8	2.2	5.18				
	444	2.3	1.7	6.75				
	218	4.4	2.7	13.73	ECP100/522	120/240/24E		
	189	5.1	2.3	15.88				
	163	5.9	2.0	18.36				
	156	6.2	1.9	19.20				
	135	7.2	1.7	22.20				
	120	8.1	1.5	25.01				
	112	8.7	1.4	26.85				
	104	9.3	1.3	28.93				
	86	11	1.1	34.97				
	66	15	0.8	45.56				
	59	15	1.6	50.89			ECP100/523	120/240/24E
	51	18	1.4	58.85				
	44	20	1.2	68.06				
	42	21	1.2	71.16				
	38	24	1.1	78.71				
	32	28	0.9	92.70				
	31	29	0.9	95.17				
	30	30	0.8	99.50				
	28	32	0.8	107.20				
	26	35	0.7	115.07				
	24	36	0.7	123.97				
	23	36	0.7	129.62				
	22	36	0.7	139.13				
	20	36	0.7	149.90				
	18	36	0.7	168.84				
	17	36	0.7	181.24				
	15	36	0.7	195.26				
	13	36	0.7	236.09				
	9.8	36	0.7	307.54				
	444	2.3	3.4	6.75	ECP100/621	120/240/24E		
	156	6.2	4.0	19.20	ECP100/622	120/240/24E		
	135	7.2	3.5	22.20				
	120	8.1	3.1	25.01				
	112	8.7	2.9	26.85				
	104	9.3	2.7	28.93				
	86	11	2.2	34.97				
	66	15	1.7	45.56				

	86	11	3.7	34.97	ECP100/722	120/240/24E
	66	15	2.9	45.56		
	44	20	4.1	68.06	ECP100/723	120/240/24E
	42	21	3.9	71.16		
	38	24	3.5	78.71		
	32	28	3.0	92.70		
	31	29	2.9	95.17		
	30	30	2.8	99.50		
	28	32	2.6	107.20		
	26	35	2.4	115.07		
	24	37	2.3	123.97		
	23	39	2.2	129.62		
	22	42	2.0	139.13		
	20	45	1.9	149.90		
	18	51	1.7	168.84		
	17	55	1.5	181.24		
	15	59	1.4	195.26		
	13	71	1.2	236.09		
	9.8	93	0.9	307.54		
	32	28	4.3	92.70	ECP100/813	120/240/24E
	31	29	4.2	95.17		
	30	30	4.0	99.50		
	28	32	3.7	107.20		
	26	35	3.5	115.07		
	24	37	3.2	123.97		
	23	39	3.1	129.62		
	22	42	2.9	139.13		
	20	45	2.7	149.90		
	18	51	2.4	168.84		
	17	55	2.2	181.24		
	15	59	2.0	195.26		
	13	71	1.7	236.09		
	9.8	93	1.3	307.54		

250						
(3000 min ⁻¹)	811	2.4	1.7	3.70	ECP180/521	120/240
	701	2.7	1.5	4.28		
	579	3.3	1.2	5.18		
	444	4.3	0.9	6.75		

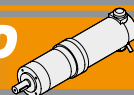

Dati tecnici per servizio S2

Technical data for S2 duty

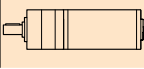
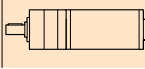
P_1 [W]	n_2 [min ⁻¹]	M_2 [Nm]	sf	i		Versione motore Motor version	P_1 [W]	n_2 [min ⁻¹]	M_2 [Nm]	sf	i		Versione motore Motor version
250							250						
(3000 min ⁻¹)	218	8.2	1.5	13.73	ECP180/522	120/240	(3000 min ⁻¹)	163	11	3.8	18.36	ECP180/722	120/240/24E
	189	9.5	1.3	15.88				156	12	3.6	19.20		
	163	11	1.1	18.36				135	13	3.2	22.20		
	156	12	1.0	19.20				120	15	2.8	25.01		
	135	13	0.9	22.20				112	16	2.6	26.85		
	120	15	0.8	25.01				104	17	2.4	28.93		
	112	16	0.7	26.85				86	21	2.0	34.97		
	104	17	0.7	28.93				66	27	1.5	45.56		
	86	17	0.7	34.97				59	28	2.9	50.89	ECP180/723	120/240/24E
	66	17	0.7	45.56				51	33	2.5	58.85		
	59	28	0.9	50.89				44	38	2.2	68.06		
	51	33	0.8	58.85				42	40	2.1	71.16		
	44	36	0.7	68.06				38	44	1.9	78.71		
	42	36	0.7	71.16				32	52	1.6	92.70		
	38	36	0.7	78.71				31	53	1.6	95.17		
	32	36	0.7	92.70				30	56	1.5	99.50		
	31	36	0.7	95.17				28	60	1.4	107.20		
	30	36	0.7	99.50				26	64	1.3	115.07		
	28	36	0.7	107.20				24	69	1.2	123.97		
	26	36	0.7	115.07	ECP180/523	120/240		23	73	1.2	129.62		
	24	36	0.7	123.97				22	78	1.1	139.13		
	23	36	0.7	129.62				20	84	1.0	149.90		
	22	36	0.7	139.13				18	95	0.9	168.84		
	20	36	0.7	149.90				17	101	0.8	181.24		
	18	36	0.7	168.84				15	109	0.8	195.26		
	17	36	0.7	181.24				13	120	0.7	236.09		
	15	36	0.7	195.26				9.8	120	0.7	307.54		
	13	36	0.7	236.09				120	15	4.0	25.01	ECP180/812	120/240/24E
	9.8	36	0.7	307.54				112	16	3.7	26.85		
	811	2.4	3.4	3.70	ECP180/621	120/240/24E		104	17	3.5	28.93		
	701	2.7	2.9	4.28				86	21	2.9	34.97		
	579	3.3	2.4	5.18				66	27	2.2	45.56		
	444	4.3	1.9	6.75				51	33	3.6	58.85	ECP180/813	120/240/24E
	218	8.2	3.0	13.73	ECP180/622	120/240/24E		44	38	3.1	68.06		
	189	9.5	2.6	15.88				42	40	3.0	71.16		
	163	11	2.3	18.36				38	44	2.7	78.71		
	156	12	2.2	19.20				32	52	2.3	92.70		
	135	13	1.9	22.20				31	53	2.3	95.17		
	120	15	1.7	25.01				30	56	2.2	99.50		
	112	16	1.6	26.85				28	60	2.0	107.20		
	104	17	1.4	28.93				26	64	1.9	115.07		
	86	21	1.2	34.97				24	69	1.7	123.97		
	66	27	0.9	45.56				23	73	1.7	129.62		
	59	28	1.8	50.89	ECP180/623	120/240/24E		22	78	1.5	139.13		
	51	33	1.5	58.85				20	84	1.4	149.90		
	44	38	1.3	68.06				18	95	1.3	168.84		
	42	40	1.3	71.16				17	101	1.2	181.24		
	38	44	1.1	78.71				15	109	1.1	195.26		
	32	52	1.0	92.70				13	132	0.9	236.09		
	31	53	0.9	95.17				9.8	172	0.7	307.54		
	30	56	0.9	99.50									
	28	60	0.8	107.20									
	26	64	0.8	115.07									
	24	69	0.7	123.97									
	23	71	0.7	129.62									
	22	71	0.7	139.13									
	20	71	0.7	149.90									
	18	71	0.7	168.84									
	17	71	0.7	181.24									
	15	71	0.7	195.26									
	13	71	0.7	236.09									
	9.8	71	0.7	307.54									

ECP

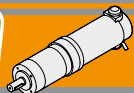

**ECP****MOTORIDUTTORI CC EPICICLOIDALI A MAGNETI PERMANENTI IN FERRITE**
*FERRITE PERMANENT MAGNETS DC PLANETARY GEARMOTORS***Dati tecnici per servizio S2****Technical data for S2 duty**

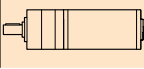
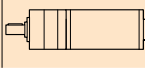
P ₁ [W]	n ₂ [min ⁻¹]	M ₂ [Nm]	sf	i		Versione motore Motor version	P ₁ [W]	n ₂ [min ⁻¹]	M ₂ [Nm]	sf	i		Versione motore Motor version
250							350						
(3000 min ⁻¹)	32	52	3.8	92.70	ECP180/1053	120/240/24E	(3000 min ⁻¹)	218	11.5	3.6	13.73	ECP250/722	120/240
	31	53	3.7	95.17									
	30	56	3.5	99.50									
	28	60	3.2	107.20									
	26	64	3.0	115.07									
	24	69	2.8	123.97									
	23	73	2.7	129.62									
	22	78	2.5	139.13									
	20	84	2.3	149.90									
	18	95	2.1	168.84									
	17	101	1.9	181.24									
	15	109	1.8	195.26									
	13	132	1.5	236.09									
	9.8	172	1.1	307.54									
	18	95	3.2	168.84	ECP180/1203	120/240/24E		59	39.9	2.1	50.89	ECP250/723	120/240
	9.8	172	1.7	307.54				51	46.1	1.8	58.85		
350							350						
(3000 min ⁻¹)	811	3.3	2.4	3.70	ECP250/621	120/240	(3000 min ⁻¹)	218	11.5	3.6	13.73	ECP250/723	120/240
	701	3.8	2.1	4.28									
	579	4.6	1.7	5.18									
	444	6.0	1.3	6.75									
	218	11.5	2.2	13.73	ECP250/622	120/240		28	84.0	1.0	107.20		
	189	13.3	1.9	15.88									
	163	15.4	1.6	18.36									
	156	16.1	1.6	19.20									
	135	18.6	1.3	22.20									
	120	21.0	1.2	25.01									
	112	22.6	1.1	26.85									
	104	24.3	1.0	28.93									
	86	29.4	0.9	34.97									
	66	38.3	0.7	45.56									
	59	39.9	1.3	50.89			ECP250/623	120/240		26	90.2	0.9	115.07
	51	46.1	1.1	58.85									
	44	53.4	0.9	68.06									
	42	55.8	0.9	71.16									
	38	61.7	0.8	78.71									
	32	72.7	0.7	92.70									
	32	74.6	0.7	95.17									
	30	71.0	0.7	99.50									
	28	71.0	0.7	107.20									
	26	71.0	0.7	115.07									
	24	71.0	0.7	123.97									
	23	71.0	0.7	129.62									
	22	71.0	0.7	139.13									
	20	71.0	0.7	149.90									
	18	71.0	0.7	168.84									
	17	71.0	0.7	181.24									
	15	71.0	0.7	195.26									
	13	71.0	0.7	236.09									
	9.8	71.0	0.7	307.54									
	811	3.3	4.2	3.70	ECP250/721	120/240		701	3.8	5.2	4.28	ECP250/811	120/240
	701	3.8	3.7	4.28									
	579	4.6	3.0	5.18									
	444	6.0	2.3	6.75									
	218	11.5	5.2	13.73	ECP250/812	120/240		579	4.6	4.3	5.18		
	189	13.3	4.5	15.88									
	163	15.4	3.9	18.36									
	156	16.1	3.7	19.20									
	135	18.6	3.2	22.20									
	120	21.0	2.9	25.01									
	112	22.6	2.7	26.85									
	104	24.3	2.5	28.93									
	86	29.4	2.0	34.97									
	66	38.3	1.6	45.56									
	59	39.9	3.0	50.89			ECP250/813	120/240		444	6.0	3.3	6.75
	51	46.1	2.6	58.85									
	44	53.4	2.2	68.06									
	42	55.8	2.2	71.16									
	38	61.7	1.9	78.71									
	32	72.7	1.7	92.70									
	32	74.6	1.6	95.17									
	30	78.0	1.5	99.50									
	28	84.0	1.4	107.20									
	26	90.2	1.3	115.07									
	24	97.2	1.2	123.97									
	23	101.6	1.2	129.62									
	22	109.1	1.1	139.13									
	20	117.5	1.0	149.90									
	18	132.4	0.9	168.84									
	17	142.1	0.8	181.24									
	15	153.1	0.8	195.26									
	13	171.0	0.7	236.09									
	9.8	171.0	0.7	307.54									

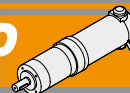

Dati tecnici per servizio S2

Technical data for S2 duty

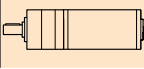
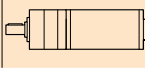
P_1 [W]	n_2 [min ⁻¹]	M_2 [Nm]	sf	i		Versione motore Motor version	P_1 [W]	n_2 [min ⁻¹]	M_2 [Nm]	sf	i		Versione motore Motor version
500							500						
(3000 min ⁻¹)	120	21.0	5.0	25.01	ECP250/1052	120/240	(3000 min ⁻¹)	17	71	0.7	181.24	ECP350/623	120/240
	112	22.6	4.7	26.85				15	71	0.7	195.26		
	104	24.3	4.3	28.93				13	71	0.7	236.09		
	86	29.4	3.6	34.97				9.8	71	0.7	307.54		
	66	38.3	2.7	45.56									
	59	39.9	4.9	50.89	ECP250/1053	120/240		811	4.6	3.0	3.70	ECP350/721	120/240
	51	46.1	4.2	58.85				701	5.4	2.6	4.28		
	44	53.4	3.7	68.06				579	6.5	2.2	5.18		
	42	55.8	3.5	71.16				444	8.5	1.7	6.75		
	38	61.7	3.2	78.71				218	16	2.6	13.73	ECP350/722	120/240
	32	72.7	2.7	92.70				189	19	2.2	15.88		
	32	74.6	2.6	95.17				163	22	1.9	18.36		
	30	78.0	2.5	99.50				156	23	1.9	19.20		
	28	84.0	2.3	107.20				135	26	1.6	22.20		
	26	90.2	2.2	115.07				120	29	1.4	25.01		
	24	97.2	2.0	123.97				112	32	1.3	26.85		
	23	101.6	1.9	129.62				104	34	1.2	28.93		
	22	109.1	1.8	139.13				86	41	1.0	34.97		
	20	117.5	1.7	149.90				66	54	0.8	45.56		
	18	132.4	1.5	168.84				59	56	1.5	50.89	ECP350/723	120/240
	17	142.1	1.4	181.24				51	65	1.3	58.85		
	15	153.1	1.3	195.26				44	75	1.1	68.06		
	13	185.1	1.1	236.09				42	78	1.1	71.16		
	9.8	241.1	0.8	307.54				38	87	1.0	78.71		
	66	38.3	3.9	45.56	ECP250/1202	120/240		32	102	0.8	92.70		
	32	72.7	4.1	92.70	ECP250/1203	120/240		31	105	0.8	95.17		
	18	132.4	2.3	168.84				30	109	0.8	99.50		
	9.8	241.1	1.2	307.54				28	118	0.7	107.20		
								26	120	0.7	115.07		
								24	120	0.7	123.97		
								23	120	0.7	129.62		
								22	120	0.7	139.13		
								20	120	0.7	149.90		
								18	120	0.7	168.84		
								17	120	0.7	181.24		
								15	120	0.7	195.26		
								13	120	0.7	236.09		
								9.8	120	0.7	307.54		
								701	5.4	3.7	4.28	ECP350/811	120/240
								579	6.5	3.1	5.18		
								444	8.5	2.4	6.75		
								218	16	3.7	13.73	ECP350/812	120/240
								189	19	3.2	15.88		
								163	22	2.8	18.36		
								156	23	2.7	19.20		
								135	26	2.3	22.20		
								120	29	2.0	25.01		
								112	32	1.9	26.85		
								104	34	1.8	28.93		
								86	41	1.5	34.97		
								66	54	1.1	45.56		
								59	56	2.1	50.89	ECP350/813	120/240
								51	65	1.9	58.85		
								44	75	1.6	68.06		
								42	78	1.5	71.16		
								38	87	1.4	78.71		
								32	102	1.2	92.70		
								31	105	1.1	95.17		
								30	109	1.1	99.50		
								28	118	1.0	107.20		



ECP

MOTORIDUTTORI CC EPICICLOIDALI A MAGNETI PERMANENTI IN FERRITE
FERRITE PERMANENT MAGNETS DC PLANETARY GEARMOTORS

Dati tecnici per servizio S2

Technical data for S2 duty

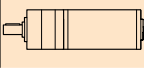
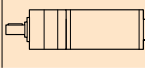
P_1 [W]	n_2 [min ⁻¹]	M_2 [Nm]	sf	i		Versione motore Motor version	P_1 [W]	n_2 [min ⁻¹]	M_2 [Nm]	sf	i		Versione motore Motor version			
500							800									
(3000 min ⁻¹)	26	126	0.9	115.07	ECP350/813	120/240	(3000 min ⁻¹)	59	90	0.9	50.89	ECP600/723	120/240			
	24	136	0.9	123.97			51	105	0.8	58.85						
	23	142	0.8	129.62			44	120	0.7	68.06						
	22	153	0.8	139.13			42	120	0.7	71.16						
	20	165	0.7	149.90			38	120	0.7	78.71						
	18	171	0.7	168.84			32	120	0.7	92.70						
	17	171	0.7	181.24			31	120	0.7	95.17						
	15	171	0.7	195.26			30	120	0.7	99.50						
	13	171	0.7	236.09			28	120	0.7	107.20						
	9.8	171	0.7	307.54			26	120	0.7	115.07						
	120	29	3.6	25.01	ECP350/1052	120/240	24	120	0.7	123.97	23	120	0.7	129.62		
	112	32	3.3	26.85			22	120	0.7	139.13						
	104	34	3.1	28.93			20	120	0.7	149.90						
	86	41	2.5	34.97			18	120	0.7	168.84						
	66	54	2.0	45.56			17	120	0.7	181.24						
	59	56	3.5	50.89	ECP350/1053	120/240	15	120	0.7	195.26	13	120	0.7	236.09		
	51	65	3.0	58.85			9.8	120	0.7	307.54						
	44	75	2.6	68.06			811	7.5	2.7	3.70	ECP600/811	120/240				
	42	78	2.5	71.16			701	8.7	2.3	4.28						
	38	87	2.3	78.71			579	11	1.9	5.18						
	32	102	1.9	92.70			444	14	1.5	6.75	ECP600/812	120/240				
	31	105	1.9	95.17			218	26	2.3	13.73						
	30	109	1.8	99.50			189	30	2.0	15.88						
	28	118	1.7	107.20			163	35	1.7	18.36						
	26	126	1.5	115.07			156	37	1.6	19.20						
	24	136	1.4	123.97	135	42	1.4	22.20								
	23	142	1.4	129.62	120	48	1.3	25.01								
	22	153	1.3	139.13	112	51	1.2	26.85								
	20	165	1.2	149.90	104	55	1.1	28.93								
	18	186	1.1	168.84	86	67	0.9	34.97								
	17	199	1.0	181.24	66	86	0.7	45.56								
	15	215	0.9	195.26	59	90	1.3	50.89	ECP600/813	120/240						
	13	259	0.8	236.09	51	105	1.1	58.85								
	9.8	279	0.7	307.54	44	121	1.0	68.06	42	127	0.9	71.16				
	66	54	2.8	45.56	ECP350/1202	120/240	38	140	0.9	78.71	32	165	0.7	92.70		
	32	102	2.9	92.70			31	169	0.7	95.17						
	18	186	1.6	168.84	ECP350/1203	120/240	30	171	0.7	99.50	28	171	0.7	107.20		
	9.8	338	0.9	307.54			26	171	0.7	115.07						
	811	7.5	1.9	3.70			ECP600/721	120/240	24	171	0.7	123.97	23	171	0.7	129.62
	701	8.7	1.6	4.28					22	171	0.7	139.13				
	579	11	1.3	5.18					20	171	0.7	149.90				
	444	14	1.0	6.75					18	171	0.7	168.84				
	218	26	1.6	13.73					17	171	0.7	181.24				
	189	30	1.4	15.88					15	171	0.7	195.26				
	163	35	1.2	18.36					13	171	0.7	236.09				
	156	37	1.1	19.20					9.8	171	0.7	307.54				
	135	42	1.0	22.20	701	8.7			4.0	4.28	ECP600/1051	120/240				
	120	48	0.9	25.01	579	11			3.3	5.18						
	112	51	0.8	26.85	444	14	2.6	6.75								
	104	55	0.8	28.93												
	86	60	0.7	34.97												
	66	60	0.7	45.56												

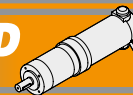

Dati tecnici per servizio S2

Technical data for S2 duty

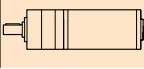
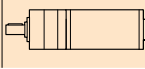
P_1 [W]	n_2 [min ⁻¹]	M_2 [Nm]	sf	i		Versione motore Motor version	P_1 [W]	n_2 [min ⁻¹]	M_2 [Nm]	sf	i		Versione motore Motor version	
800							800							
(3000 min ⁻¹)	218	26	4.0	13.73	ECP600/1052	120/240	(3000 min ⁻¹)	120	48	3.1	25.01	ECP600/1202	120/240	
	189	30	3.5	15.88				66	87	1.7	45.56			
	163	35	3.0	18.36										
	156	37	2.9	19.20				59	90	3.3	50.89	ECP600/1203	120/240	
	135	42	2.5	22.20				32	165	1.8	92.70			
	120	48	2.2	25.01				18	300	1.0	168.84			
	112	51	2.1	26.85				9.8	429	0.7	307.54			
	104	55	1.9	28.93										
	86	67	1.6	34.97										
	66	87	1.2	45.56										
	59	90	2.2	50.89	ECP600/1053	120/240								
	51	105	1.9	58.85										
	44	121	1.6	68.06										
	42	127	1.5	71.16										
	38	140	1.4	78.71										
	32	165	1.2	92.70										
	31	169	1.2	95.17										
	30	177	1.1	99.50										
	28	191	1.0	107.20										
	26	205	1.0	115.07										
	24	220	0.9	123.97										
	23	230	0.8	129.62										
	22	247	0.8	139.13										
	20	267	0.7	149.90										
	18	279	0.7	168.84										
	17	279	0.7	181.24										
	15	279	0.7	195.26										
	13	279	0.7	236.09										
	9.8	279	0.7	307.54										

ECP

Motori applicabili

IEC Motor adapters

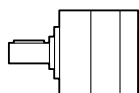
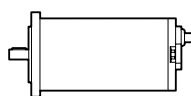

		EC								
		020.120 020.24E	035.120 035.240	050.12E 050.24E	070.120 070.240	100.120 100.240 100.24E	180.120 180.240	180.24E	250.120 250.240	350.120 350.240
P	42									
	52									
	62									
	72									
	81									
	105									
	120									

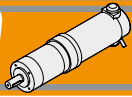

ECP

MOTORIDUTTORI CC EPICICLOIDALI A MAGNETI PERMANENTI IN FERRITE
FERRITE PERMANENT MAGNETS DC PLANETARY GEARMOTORS

Dimensioni

Dimensions

ECP020/42... U

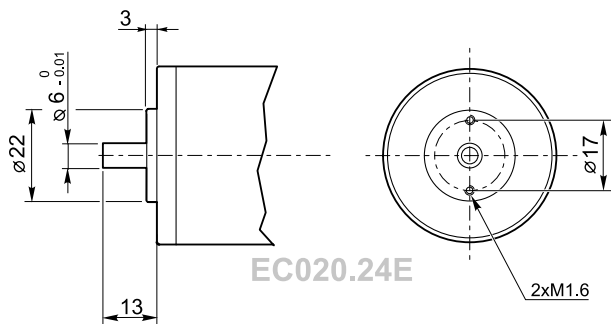
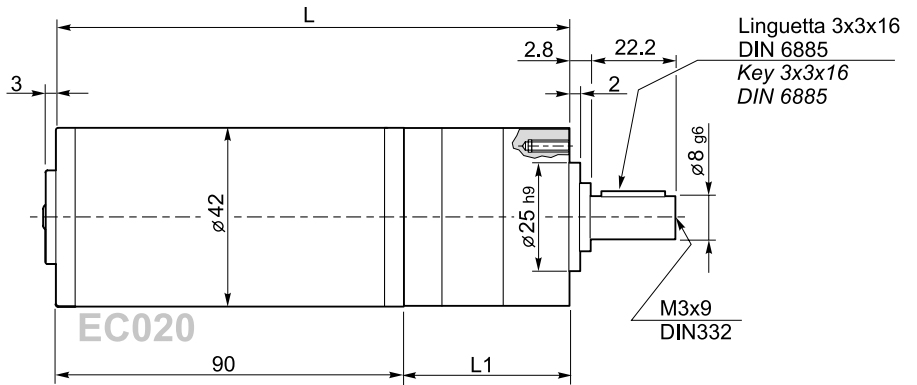
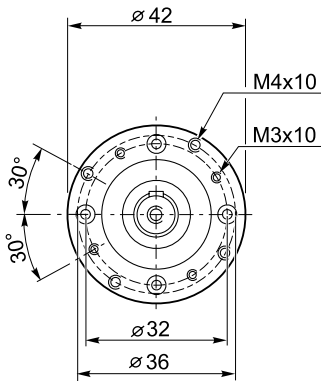

	Numero di stadi / Stages number		
ECP020/42...	1	2	3
L1	60	73	86
L	150	163	176

ECP035/... U

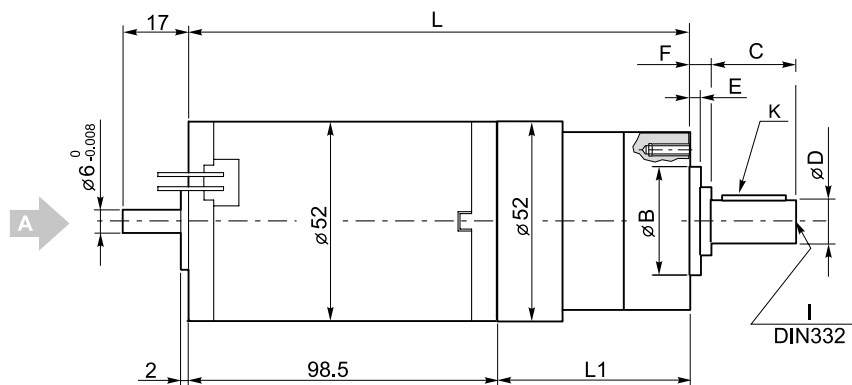
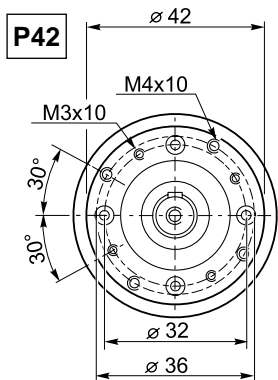

Vista / View
A

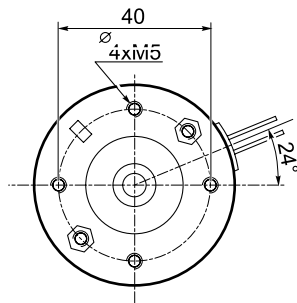
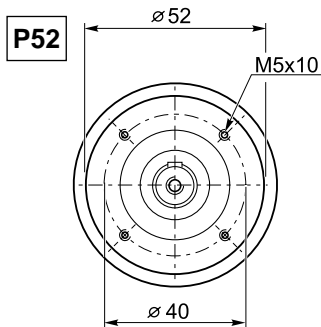

Tipo Type	Numero di stadi Stages number	Dimensioni / Dimensions								
		L1	L	B	C	D	E	F	I	K
ECP035/42...	1	60	158.5	25 h9	22.2	8 g6	2	2.8	M3x9	3x3x16
	2	73	171.5							
	3	86	184.5							
ECP035/52...	1	72.5	175.5	32 h8	20.8	12 h7	3	4.2	M4x10	4x4x16
	2	86.5	189.5							
	3	100.5	203.5							

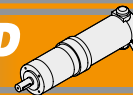

Dimensioni

Dimensions

ECP050/... U

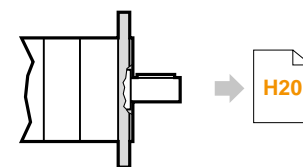
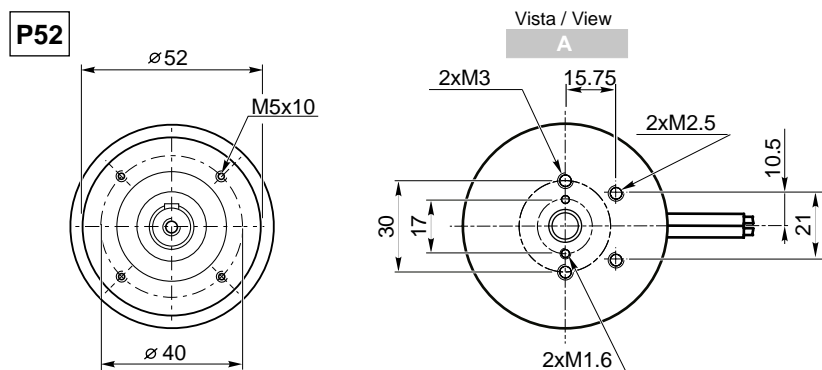
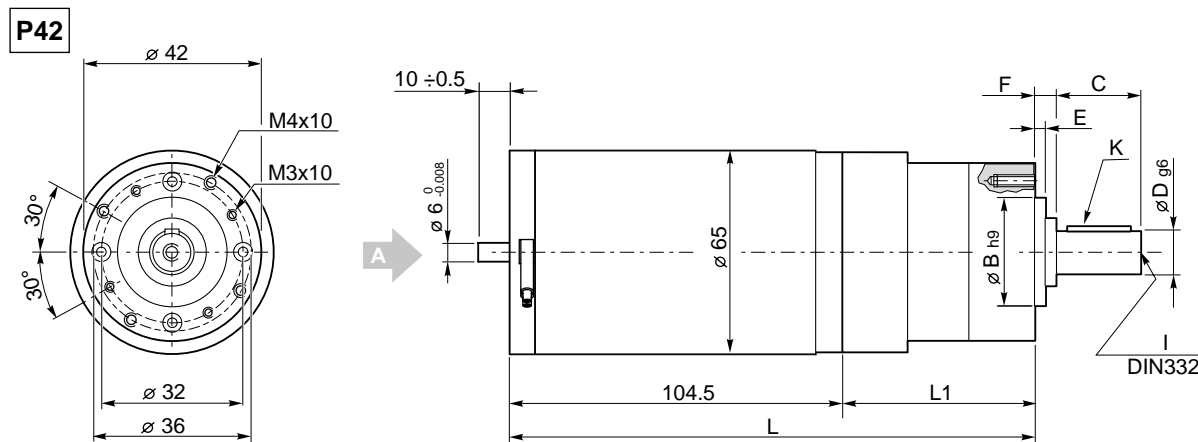

ECP050/... C...

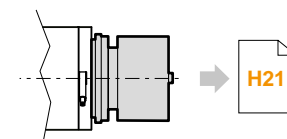

ECP050/... U.. BR
ECP050/... U.. BRL

ECP

Tipo Type	Numero di stadi Stages number	Dimensioni / Dimensions								
		L1	L	B	C	D	E	F	I	K
ECP050/42...	1	60	164.5	25 h9	22.2	8 g6	2	2.8	M3x9	3x3x16
	2	73	177.5							
	3	86	190.5							
ECP050/52...	1	72.5	177	32 h8	20.8	12 h7	3	4.2	M4x10	4x4x16
	2	86.5	191							
	3	100.5	205							

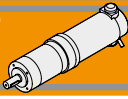

ECP

MOTORIDUTTORI CC EPICICLOIDALI A MAGNETI PERMANENTI IN FERRITE
FERRITE PERMANENT MAGNETS DC PLANETARY GEARMOTORS

Dimensioni

Dimensions

ECP070/... U

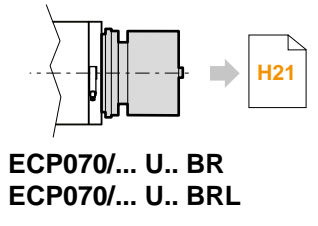
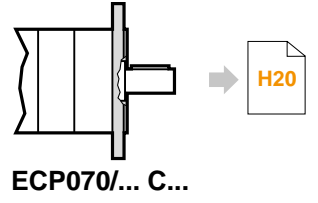
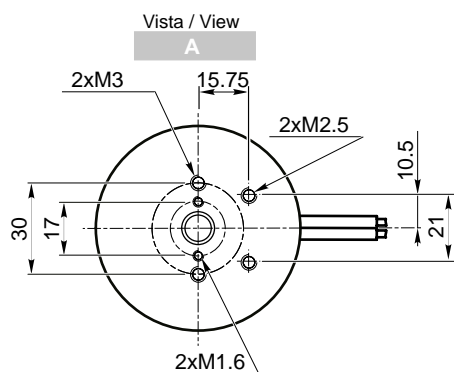
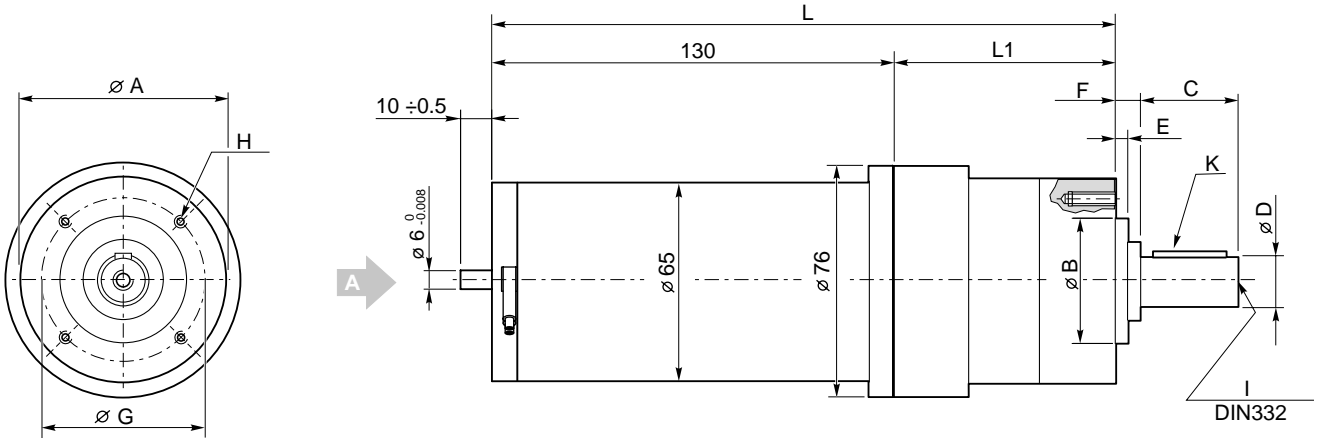

Tipo Type	Numero di stadi Stages number	Dimensioni / Dimensions											
		L1	L	A	B	C	D	E	F	G	H	I	K
ECP070/52...	1	74	204	52	32 h8	20.8	12 h7	3	4.2	40	M5x10	M4x10	4x4x16
	2	88	218										
	3	102	232										
ECP070/62...	1	74	204	62	40 j7	30	14 h7	5	9	52	M5x10	M5x12	5x5x18
	2	90	220										
	3	106	236										
ECP070/72...	1	82.4	212.4	72	45 j7	40	16 h7	5	9	60	M5x10	M5x12	5x5x30
	2	102	232										
	3	121.6	251.6										
ECP070/81...	1	91	221	81	50 j7	40	19 h7	5	9	65	M6x12	M6x16	6x6x28
	2	113	243										
	3	135	265										

Dimensioni

Dimensions

ECP100/... U... 120/140

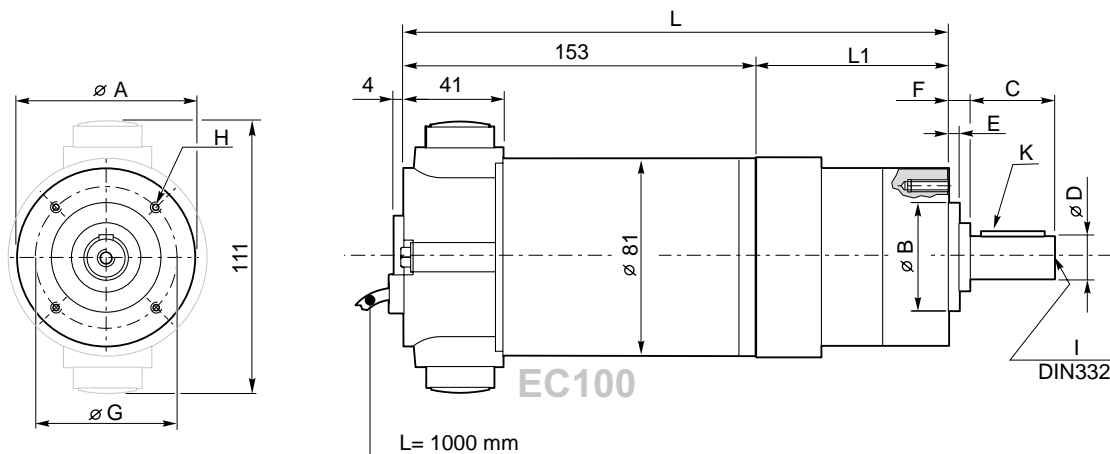

ECP100/... U... 24E

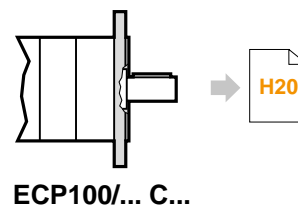
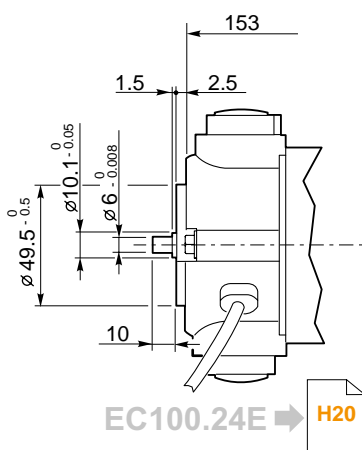

ECP100/... C...

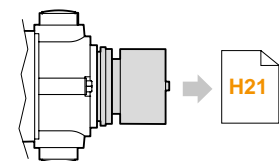

ECP100/... U.. BR
ECP100/... U.. BRL

ECP

Tipo Type	Numero di stadi Stages number	Dimensioni / Dimensions											
		L1	L	A	B	C	D	E	F	G	H	I	K
ECP100/52...	1	74	227	52	32 h8	20.8	12 h7	3	4.2	40	M5x10	M4x10	4x4x16
	2	88	241										
	3	102	255										
ECP100/62...	1	74	227	62	40 j7	30	14 h7	5	9	52	M5x10	M5x12	5x5x18
	2	90	243										
	3	106	259										
ECP100/72...	1	82.4	235.4	72	45 j7	40	16 h7	5	9	60	M5x10	M5x12	5x5x30
	2	102	255										
	3	121.6	274.6										
ECP100/81...	1	91	244	81	50 j7	40	19 h7	5	9	65	M6x12	M6x16	6x6x28
	2	113	266										
	3	135	288										

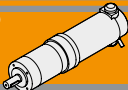

ECP

MOTORIDUTTORI CC EPICICLOIDALI A MAGNETI PERMANENTI IN FERRITE
FERRITE PERMANENT MAGNETS DC PLANETARY GEARMOTORS

Dimensioni

Dimensions

ECP180/... U... 120/240

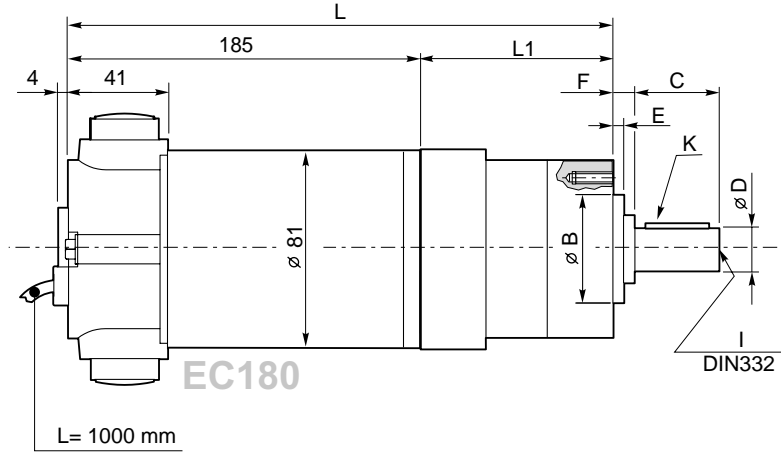
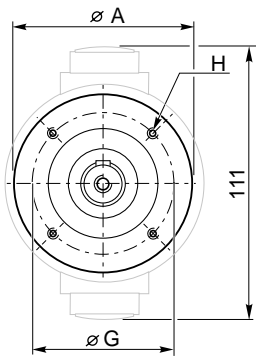

ECP180/... U... 24E

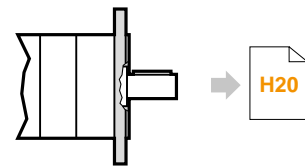
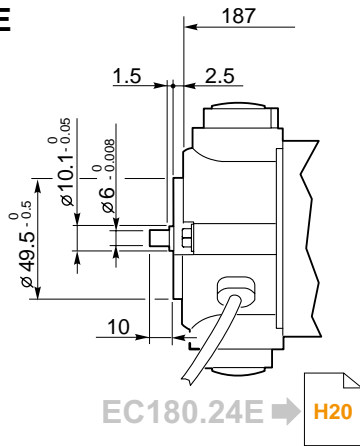

ECP180/... C...

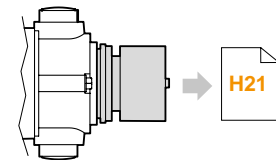

ECP180/... U... BR
ECP180/... U... BRL

Tipo Type	Numero di stadi Stages number	Dimensioni / Dimensions													
		EC180		EC180.24E		EC180 - EC180.24E									
		L1	L	L1	L	A	B	C	D	E	F	G	H	I	K
ECP180/52...	1	74	259			52	32 h8	20.8	12 h7	3	4.2	40	M5x10	M4x10	4x4x16
	2	88	273												
	3	102	287												
ECP180/62...	1	74	259	76	263	62	40 j7	30	14 h7	5	9	52	M5x10	M5x12	5x5x18
	2	90	275	92	279										
	3	106	291	108	295										
ECP180/72...	1	82.4	267.4	88.4	275.4	72	45 j7	40	16 h7	5	9	60	M5x10	M5x12	5x5x30
	2	102	287	108	295										
	3	121.6	306.6	127.6	314.6										
ECP180/81...	1	91	276	94	281	81	50 j7	40	19 h7	5	9	65	M6x12	M6x16	6x6x28
	2	113	298	116	303										
	3	135	320	138	325										
ECP180/105...	1	113.4	298.4	116.4	303.4	105	70 j7	50	25 h7	5	9	85	M8x16	M10x22	8x7x40
	2	144.5	329.5	147.5	334.5										
	3	175.5	360.5	178.5	365.5										
ECP180/120...	1	131.6	316.6	134.5	321.4	120	80 j7	73	32 k6	5	15	100	M10x22	M12	10x8x50
	2	165.8	350.8	168.6	355.6										
	3	200	385	202.8	389.8										

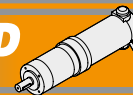

Dimensioni

Dimensions

ECP250/... U

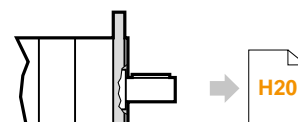
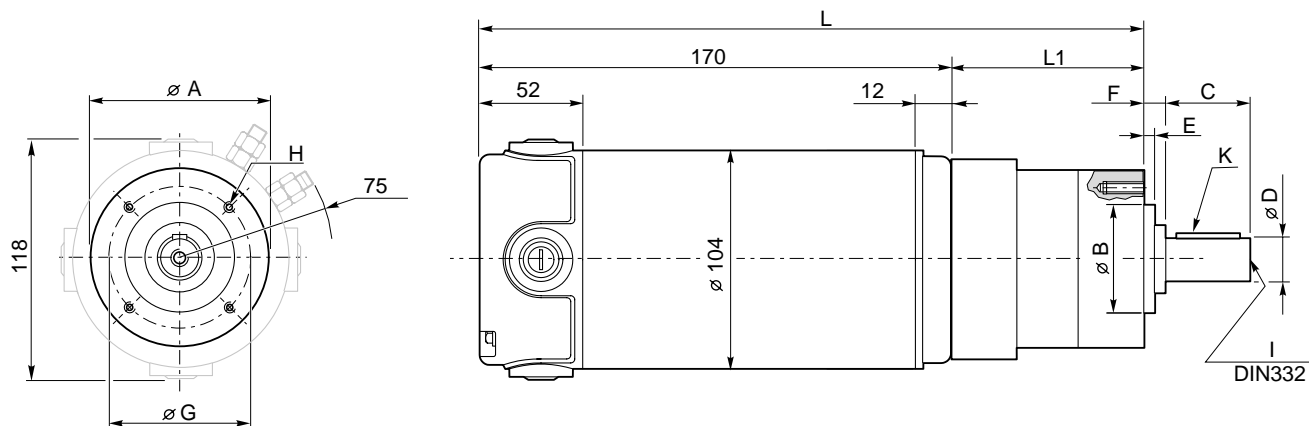

ECP250/... C...

Tipo Type	Numero di stadi Stages number	Dimensioni / Dimensions											
		L1	L	A	B	C	D	E	F	G	H	I	K
ECP250/62...	1	76	246	62	40 j7	30	14 h7	5	9	52	M5x10	M5x12	5x5x18
	2	92	262										
	3	108	278										
ECP250/72...	1	85.4	255.4	72	45 j7	40	16 h7	5	9	60	M5x10	M5x12	5x5x30
	2	105	275										
	3	124.6	294.6										
ECP250/81...	1	94	264	81	50 j7	40	19 h7	5	9	65	M6x12	M6x16	6x6x28
	2	116	286										
	3	138	308										
ECP250/105...	1	113.4	283.4	105	70 j7	50	25 h7	5	9	85	M8x16	M10x22	8x7x40
	2	144.5	314.5										
	3	175.5	345.5										
ECP250/120...	1	131.6	301.6	120	80 j7	73	32 k6	5	15	100	M10x22	M12	10x8x50
	2	165.8	335.8										
	3	200	370										

ECP

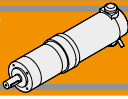

ECP

MOTORIDUTTORI CC EPICICLOIDALI A MAGNETI PERMANENTI IN FERRITE
FERRITE PERMANENT MAGNETS DC PLANETARY GEARMOTORS

Dimensioni

Dimensions

ECP350/... U

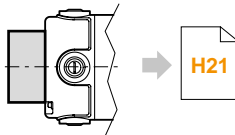
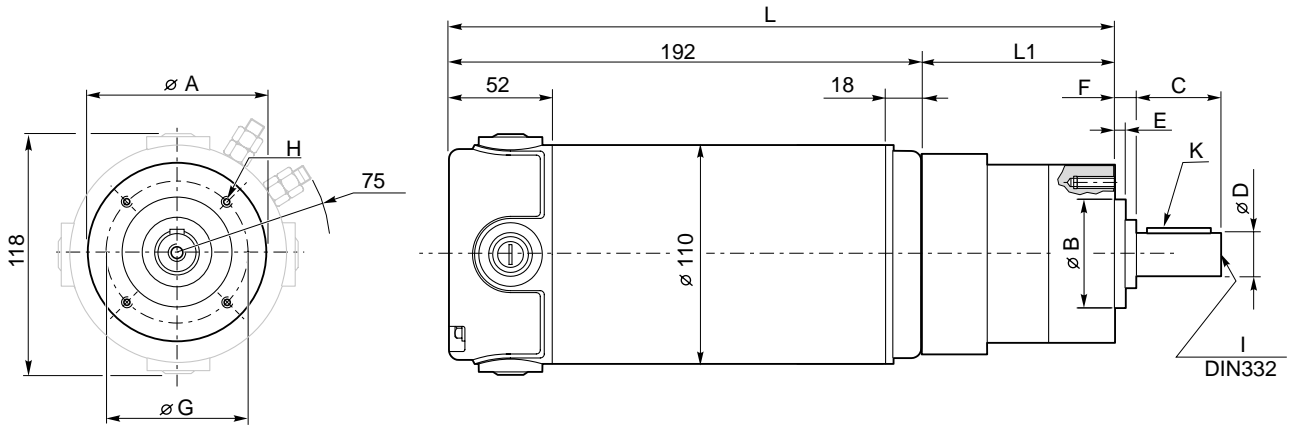

ECP350/... U.. BR
ECP350/... U.. BRL

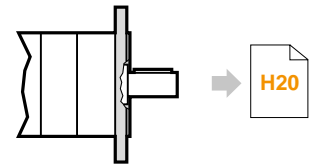

ECP350/... C...

Tipo Type	Numero di stadi Stages number	Dimensioni / Dimensions											
		L1	L	A	B	C	D	E	F	G	H	I	K
ECP350/62...	1	76	268	62	40 j7	30	14 h7	5	9	52	M5x10	M5x12	5x5x18
	2	92	284										
	3	108	300										
ECP350/72...	1	85.4	277.4	72	45 j7	40	16 h7	5	9	60	M5x10	M5x12	5x5x30
	2	105	297										
	3	124.6	316.6										
ECP350/81...	1	94	286	81	50 j7	40	19 h7	5	9	65	M6x12	M6x16	6x6x28
	2	116	308										
	3	138	330										
ECP350/105...	1	113.4	305.4	105	70 j7	50	25 h7	5	9	85	M8x16	M10x22	8x7x40
	2	144.5	336.5										
	3	175.5	367.5										
ECP350/120...	1	131.6	323.6	120	80 j7	73	32 k6	5	15	100	M10x22	M12	10x8x50
	2	165.8	357.8										
	3	200	392										

Dimensioni

Dimensions

ECP600/... U

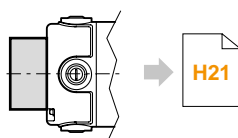
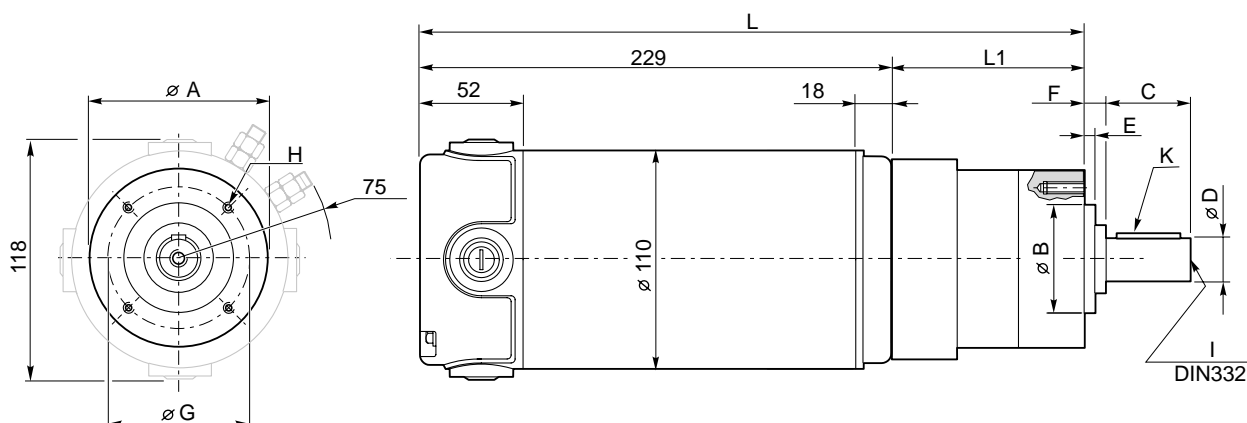

ECP600/... U.. BR
ECP600/... U.. BRL

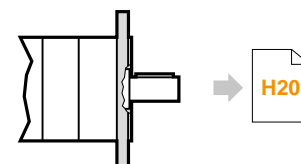

ECP600/... C...

Tipo Type	Numero di stadi Stages number	Dimensioni / Dimensions											
		L1	L	A	B	C	D	E	F	G	H	I	K
ECP600/72...	1	92.4	321.4	72	45 j7	40	16 h7	5	9	60	M5x10	M5x12	5x5x30
	2	112	341										
	3	131.6	360.6										
ECP600/81...	1	101	330	81	50 j7	40	19 h7	5	9	65	M6x12	M6x16	6x6x28
	2	123	352										
	3	145	374										
ECP600/105...	1	120.4	349.4	105	70 j7	50	25 h7	5	9	85	M8x16	M10x22	8x7x40
	2	151.5	380.5										
	3	182.5	411.5										
ECP600/120...	1	133.7	362.7	120	80 j7	73	32 k6	5	15	100	M10x22	M12	10x8x50
	2	167.9	396.9										
	3	202.1	431.1										

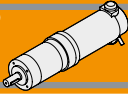

ECP

MOTORIDUTTORI CC EPICICLOIDALI A MAGNETI PERMANENTI IN FERRITE
FERRITE PERMANENT MAGNETS DC PLANETARY GEARMOTORS

Dimensioni

Dimensions

ECP100.24E
ECP180.24E

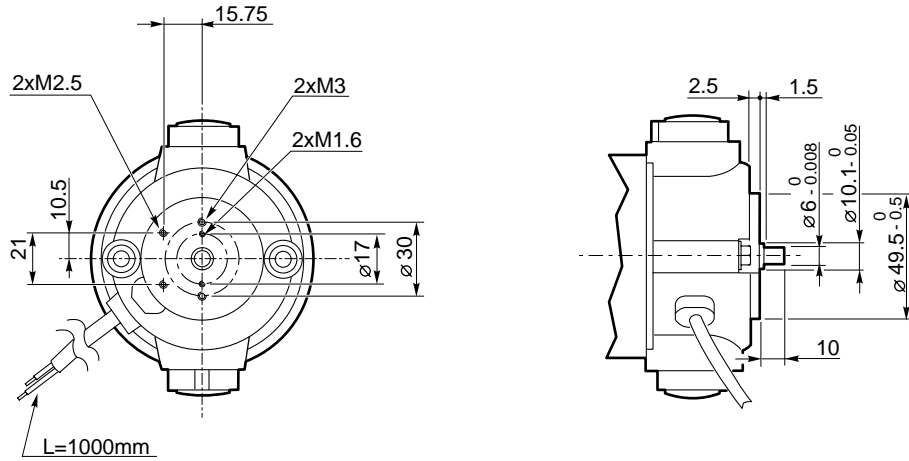

ECP.../... C... Flange uscita / Output flanges

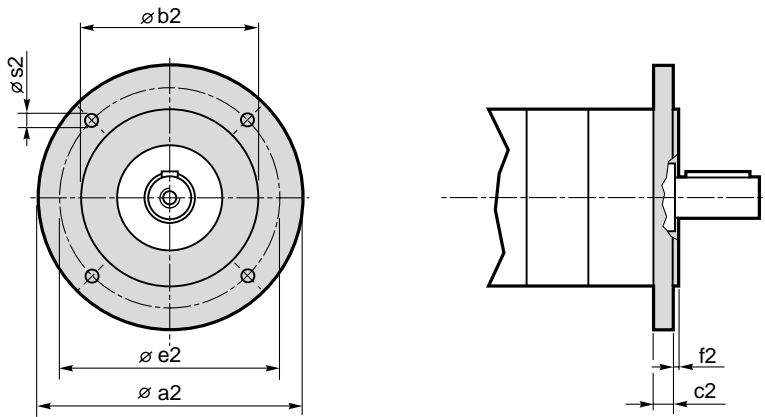

Dimensioni / Dimensions

P	a2	b2	c2	e2	f2	s2	Flangia uscita Output flange
52	80	50 j7	9	65	2.5	M5	C80
	90	60 j7	9	75	2.5	5.5	C90
	105	70 j7	9	85	2.5	6.5	C105
	120	80 j7	9	100	3.0	6.5	C120
62	80	50 j7	9	65	2.5	M5	C80
	90	60 j7	9	75	2.5	5.5	C90
	105	70 j7	9	85	2.5	6.5	C105
	120	80 j7	9	100	3.0	6.5	C120
72	80	50 j7	9	65	2.5	M5	C80
	90	60 j7	9	75	2.5	M5	C90
	105	70 j7	9	85	2.5	6.5	C105
	120	80 j7	9	100	3.0	6.5	C120
81	90	60 j7	9	75	2.5	M5	C90
	105	70 j7	9	85	2.5	M6	C105
	120	80 j7	9	100	3.0	6.5	C120
105	120	80 j7	12	100	3	M6	C120
	140	95 j7	12	115	3.5	M8	C140
	160	110 j7	12	130	3.5	M8	C160
120	140	95 j7	15	115	3	M8	C140
	160	110 j7	15	130	3.5	M8	C160

Dimensioni

Dimensions

Freno / Brake

Freno con leva di sblocco/ Brake with hand release

ECP50/... U BR
ECP70/... U BR

ECP50/... U BRL
ECP70/... U BRL

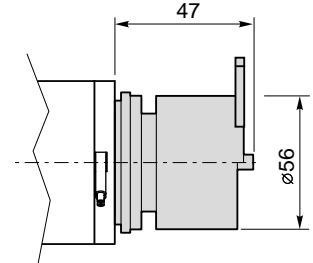
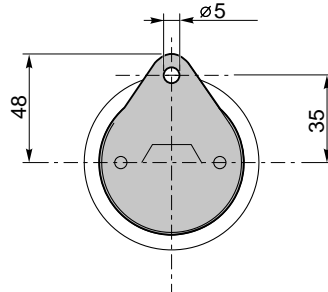
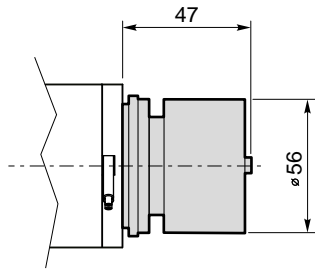

ECP100/... U BR
ECP180/... U BR

ECP100/... U BRL
ECP180/... U BRL

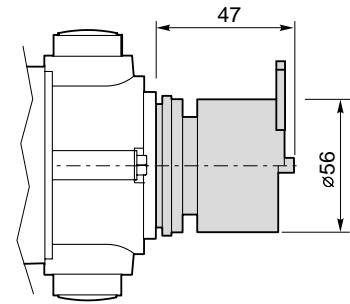
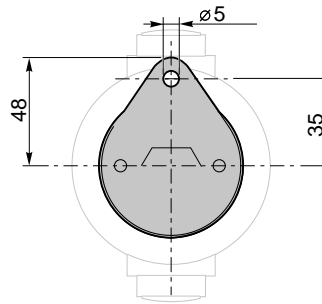
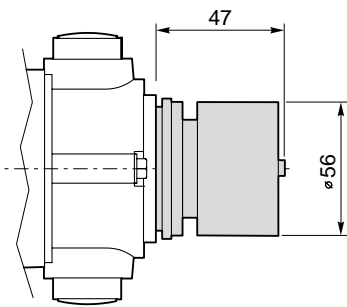

ECP350/... U BR
ECP600/... U BR

ECP350/... U BRL
ECP600/... U BRL

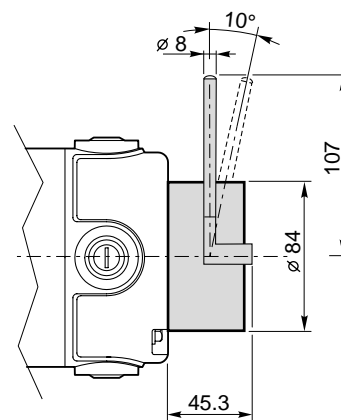
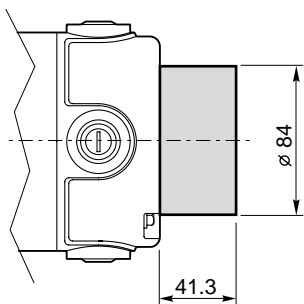

ECP

TRANSTECNO[®]
the modular gearmotor

ECWMP

ECWMP



Motoriduttori CC combinati
a magneti permanenti in ferrite
Ferrite permanent magnets
DC Double reduction gearmotors



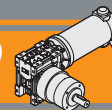

Indice	Index	Pag. Page
Caratteristiche tecniche	<i>Technical features</i>	12
Designazione	<i>Classification</i>	12
Versioni	<i>Versions</i>	12
Simbologia	<i>Symbols</i>	12
Lubrificazione	<i>Lubrication</i>	12
Carichi radiali	<i>Radial loads</i>	13
Rapporti	<i>Ratios</i>	13
Dati tecnici	<i>Technical data</i>	14
Dimensioni	<i>Dimensions</i>	15

Questa sezione annulla e sostituisce ogni precedente edizione o revisione. Qualora questa sezione non Vi sia giunta in distribuzione controllata, l'aggiornamento dei dati ivi contenuto non è assicurato. **In tal caso la versione più aggiornata è disponibile sul nostro sito internet www.transtecno.com**

*This section replaces any previous edition and revision. If you obtained this catalogue other than through controlled distribution channels, the most up to date content is not guaranteed. **In this case the latest version is available on our web site www.transtecno.com***

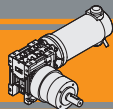

ECWMP

MOTORIDUTTORI CC COMBINATI A MAGNETI PERMANENTI IN FERRITE FERRITE PERMANENT MAGNETS DC DOUBLE REDUCTION GEARMOTORS

Caratteristiche tecniche

Technical features

L'accoppiamento di un riduttore a vite senza fine con un riduttore epicicloidale consente di ottenere elevati rapporti di riduzione ($i_{max} = 1/18452$) e di disporre di un gruppo autolubrificato compatto, silenzioso e con un'elevata affidabilità.

The coupling of a wormgearbox to a planetary gearbox allows to obtain high reduction ratios ($i_{max} = 1/18452$) and to get a compact, silent, self lubricated with high reliability group.

Designazione

Classification

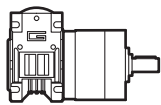
MOTORIDUTTORE / GEARMOTOR										
ECWMP	070/026/52				2	CD	90	405	240	BR
Tipo Type	Grandezza Size				Numero stadi epicicloidale Planetary stages number	Versione Riduttore Gearbox Version	Flangia Uscita Output flange	Rapporto Ratio	Versione Motore Motor Version	Opzioni Options
	070/026/52	100/026/52	180/026/62	250/030/81	350/030/81	1	80	Vedere tabella See tables	120	BR BRL
	070/026/62	100/026/62	180/030/81			2	90		240	
	070/030/81	100/030/81				3	105		24E	
							120			

Versioni

Versions

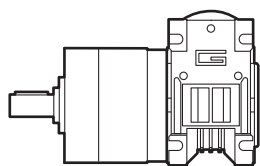

US

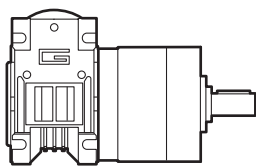

UD

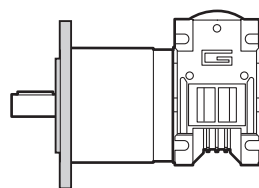

CS

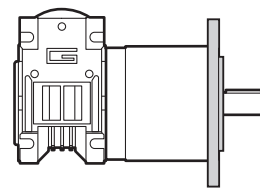

CD

Simbologia

Symbols

- n_1 [min^{-1}] Velocità in ingresso / *Input speed*
- n_2 [min^{-1}] Velocità in uscita / *Output speed*
- i Rapporto di riduzione / *Ratio*
- P_1 [kW] Potenza in entrata / *Input power*
- M_n [Nm] Coppia nominale in uscita del riduttore / *Maximum output torque of the gearbox*
- M_2 [Nm] Coppia in uscita in funzione di P_1 / *Output torque referred to P_1*
- sf Fattore di servizio / *Service factor*
- Rd % Rendimento dinamico / *Dynamic efficiency*
- A_2 [N] Carico assiale ammissibile in uscita / *Permitted output axial load*
- R_2 [N] Carico radiale ammissibile in uscita / *Permitted output radial load*

Lubrificazione

Lubrication

I riduttori a vite senza fine della serie CM sono lubrificati a vita con olio sintetico di viscosità 320 e possono essere installati in qualunque posizione di montaggio.

Permanent synthetic oil long-life lubrication allow to use CM wormgearbox range in all mounting position.

I riduttori epicicloidali sono lubrificati in modo permanente, non richiedono quindi ulteriore manutenzione. Questo gli consente di essere installati praticamente ovunque.

Planetary gearboxes are life-time lubricated with grease, therefore they are maintenance free. They can be installed in any location.

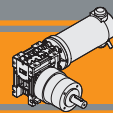

Carichi radiali

Radial loads

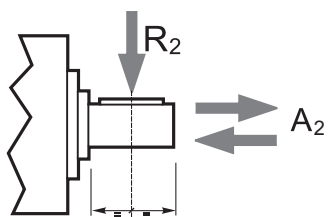

Numero di stadi Stages number	Carichi Radiali R_2 [N] Radial Load R_2 [N]		
	P52	P62	P81
1	200	240	400
2	320	360	600
3	450	520	1000

Numero di stadi Stages number	Carichi Assiali A_2 [N] Axial Load A_2 [N]		
	P52	P62	P81
1	60	70	80
2	100	100	120
3	150	150	200

Rapporti

Ratios

Motoriduttore Gearmotor	Numero stadi epicicloidale Planetary stages number	Rapporto epicicloidale Planetary ratio	Rapporto vite senza fine Wormgearbox ratio	Rapporto finale Total ratio
.../026/052 .../026/062 .../030/081	1	6.75	10	67.5
			15	101.3
			20	135
			30	202.5
			40	270
			50	337.5
	2	28.93	10	289.3
			15	434.0
			20	578.6
			30	867.9
			40	1157
			50	1447
			60	1736
			60	2098
	34.97	60	2098	
	45.56	60	2734	

ECWMP

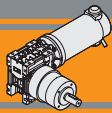

Dati tecnici per servizio S2

Technical data for S2 duty

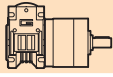
P_1 [W]	n_2 [min ⁻¹]	M_2 [Nm]	sf	i		Versione motore Motor version
100						
(3000 min ⁻¹)	44.4	14	1.8	67.5	070/026/521	120/240
	29.6	21	1.2	101.3		
	22.2	25	1.0	135.0		
	14.8	25	1.0	202.5		
	11.1	25	1.0	270.0		
	10.4	25	1.0	289.3	070/026/522	120/240
	8.9	25	1.0	337.5	070/026/521	120/240
	7.4	25	1.0	405		
	6.9	25	1.0	434	070/026/522	120/240
	5.2	25	1.0	579		
	3.5	25	1.0	868		
	2.6	25	1.0	1157		
	2.1	25	1.0	1447		
	1.7	25	1.0	1736		
	1.4	25	1.0	2098		
1.1	25	1.0	2734			
44.4	14	2.8	67.5	070/026/621	120/240	
29.6	21	1.9	101.3			
22.2	27	1.5	135.0			
14.8	37	1.1	202.5			
11.1	40	1.0	270.0			
10.4	50	1.0	289.3	070/026/622	120/240	
8.9	40	1.0	337.5	070/026/621	120/240	
7.4	40	1.0	405.0			
6.9	50	1.0	434.0	070/026/622	120/240	
5.2	50	1.0	578.6			
3.5	50	1.0	867.9			
2.6	50	1.0	1157			
2.1	50	1.0	1447			
1.7	50	1.0	1736			
1.4	50	1.0	2098			
1.1	50	1.0	2734			
44.4	14	5.6	67.5	070/030/811	120/240	
29.6	21	3.8	101.3			
22.2	27	2.9	135.0			
14.8	37	2.2	202.5			
11.1	47	1.7	270.0			
10.4	58	2.1	289.3	070/030/812	120/240	
8.9	54	1.5	337.5	070/030/811	120/240	
7.4	62	1.3	405.0			
6.9	85	1.4	434.0	070/030/812	120/240	
5.2	109	1.1	578.6			
3.5	120	1.0	867.9			
2.6	120	1.0	1157			
2.1	120	1.0	1447			
1.7	120	1.0	1736			
1.4	120	1.0	2098			
1.1	120	1.0	2734			

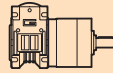
P_1 [W]	n_2 [min ⁻¹]	M_2 [Nm]	sf	i		Versione motore Motor version
140						
(3000 min ⁻¹)	44.4	20	1.3	67.5	100/026/521	120/240/24E
	29.6	25	1.0	101.3		
	22.2	37	1.1	135.0		
	14.8	40	1.0	202.5		
	11.1	65	1.2	270.0		
	44.4	20	2.0	67.5	100/026/621	120/240/24E
	29.6	29	1.4	101.3		
	22.2	38	2.1	135.0		
	14.8	52	1.6	202.5		
	11.1	65	1.2	270.0		
	10.4	80	1.5	289.3	100/030/812	120/240/24E
	8.9	75	1.1	337.5	100/030/811	120/240/24E
	7.4	80	1.0	405.0		
	6.9	120	1.0	434.0	100/030/812	120/240/24E
	5.2	120	1.0	578.6		

250						
(3000 min ⁻¹)	44.4	37	1.1	67.5	180/026/621	120/240
	29.6	40	1.0	101.3		
	22.2	40	1.0	135.0		
	14.8	80	1.0	202.5		
	11.1	80	1.0	270.0		
	44.4	37	2.2	67.5	180/030/811	120/240/24E
	29.6	54	1.5	101.3		
	22.2	70	1.1	135.0		
	14.8	80	1.0	202.5		
	11.1	80	1.0	270.0		
	10.4	120	1.0	289.3	180/030/812	120/240/24E
	8.9	80	1.0	337.5	180/030/811	120/240/24E

350						
(3000 min ⁻¹)	44.4	52	1.5	67.5	250/030/811	120/240
	29.6	76	1.1	101.3		
	22.2	80	1.0	135.0		
	14.8	80	1.0	202.5		
	11.1	80	1.0	270.0		

500						
(3000 min ⁻¹)	44.4	73	1.1	67.5	350/030/811	120/240
	29.6	80	1.0	101.3		
	22.2	80	1.0	135.0		

Nota: Verificare sempre che la coppia M2 utilizzata non ecceda il valore indicato nelle caselle in grigio

Note: Please check that the output torque M2 does not exceed the value into the grey areas

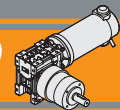

Dimensioni

Dimensions

ECWMP070/026/52...U

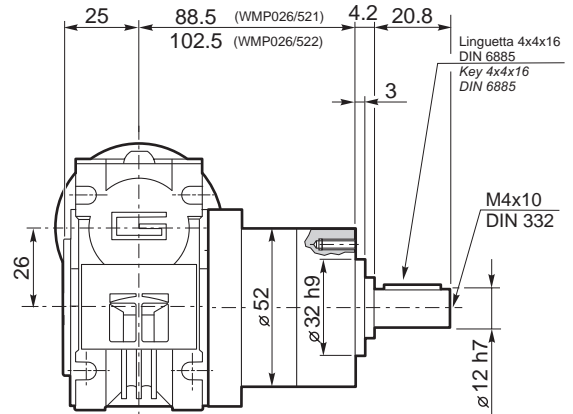
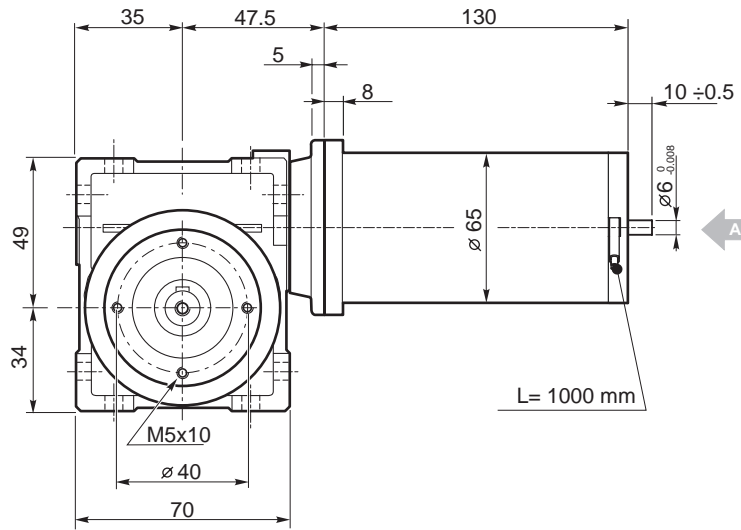

Vista / View
A

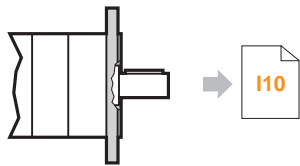
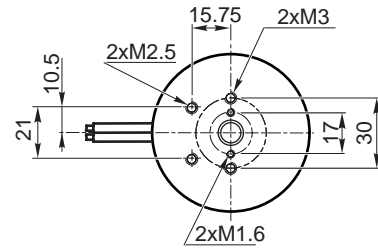

ECWMP070/026/52...C

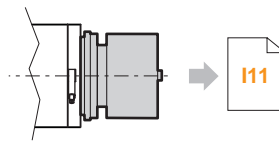

ECP070/026/52...U BR
ECP070/026/52...U BRL

ECWMP070/026/62...U

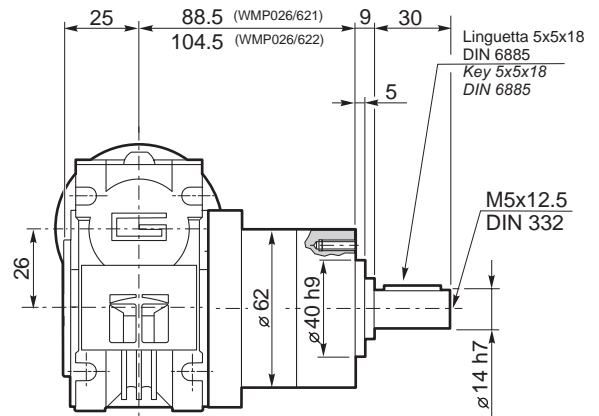
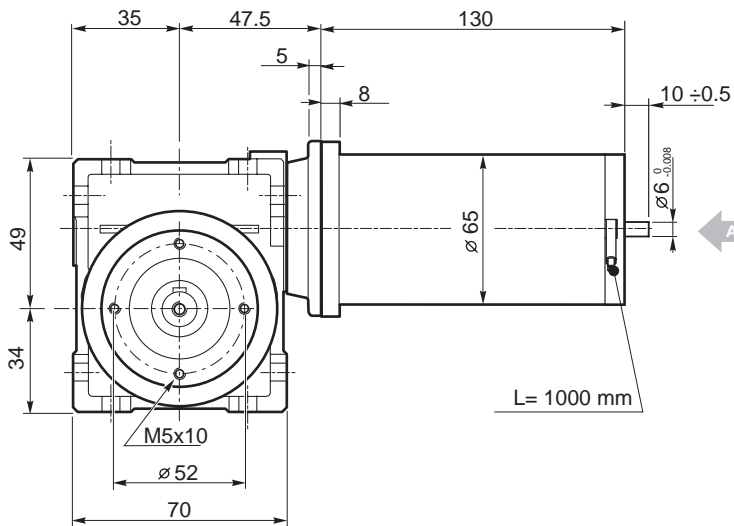

Vista / View
A

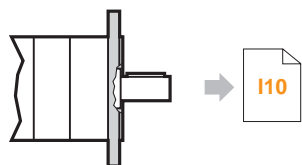
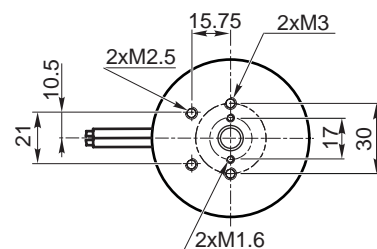

ECWMP070/026/62...C

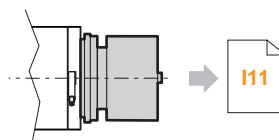

ECP070/026/62...U BR
ECP070/026/62...U BRL

ECWMP

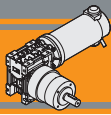

ECWMP

MOTORIDUTTORI CC COMBINATI A MAGNETI PERMANENTI IN FERRITE FERRITE PERMANENT MAGNETS DC DOUBLE REDUCTION GEARMOTORS

Dimensioni

Dimensions

ECWMP070/030/81...U

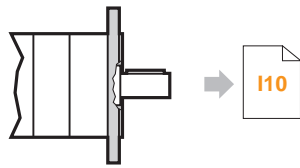
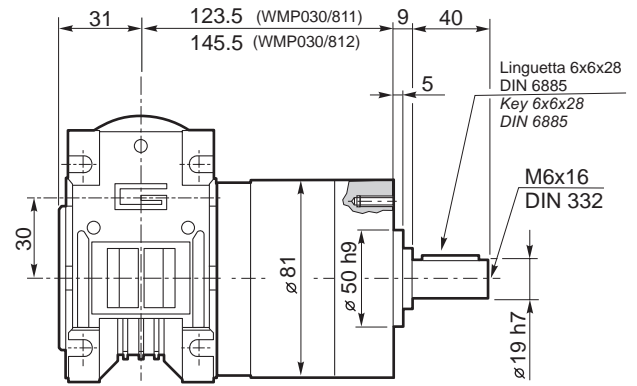
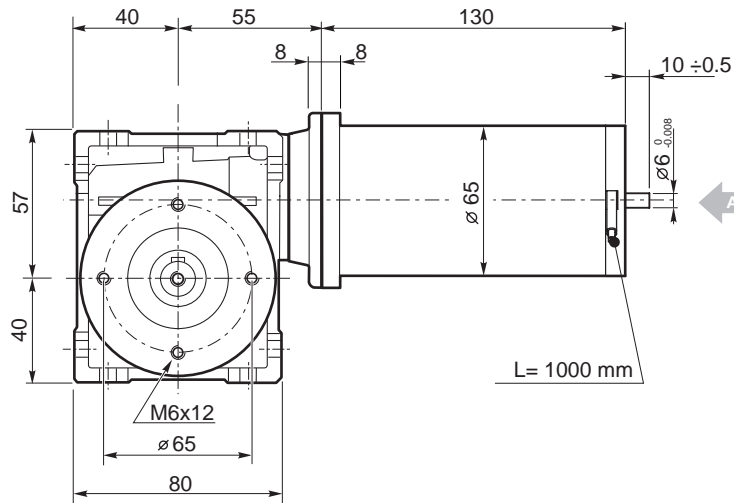

ECWMP070/030/81...C

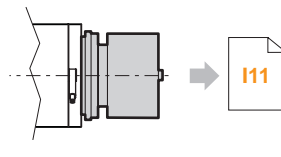

ECP070/030/81...U BR
ECP070/030/81...U BRL

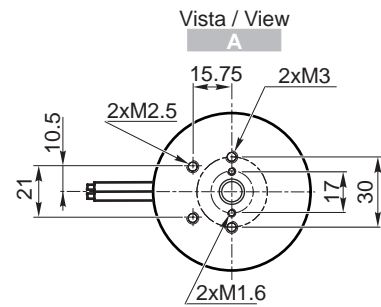

ECWMP100/026/52...U

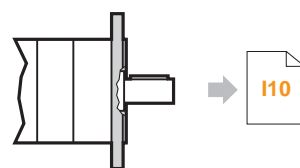
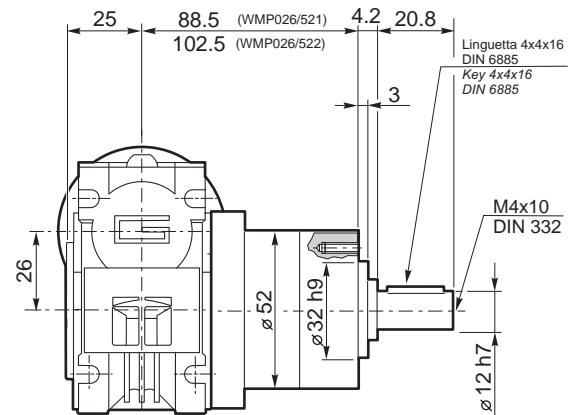
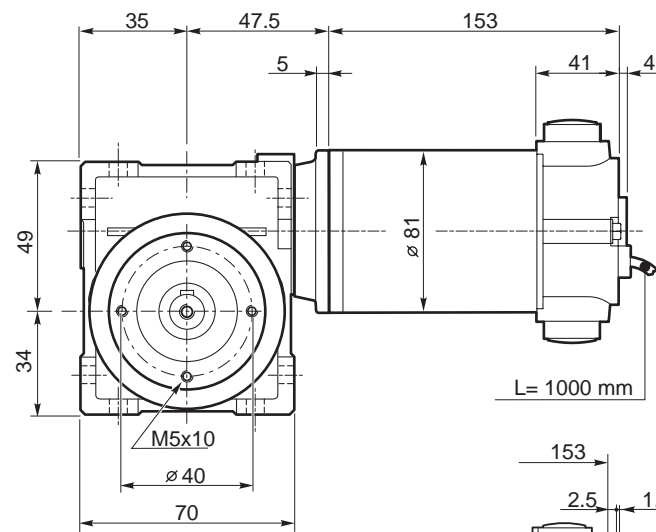

ECWMP100/026/52...C

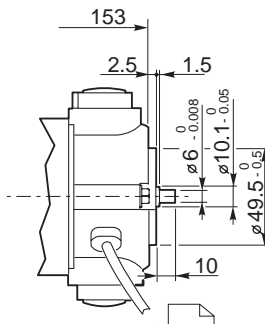

EC100.24E

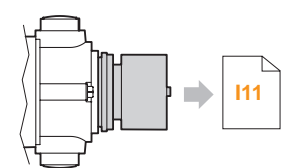

ECP100/026/52...U BR
ECP100/026/52...U BRL

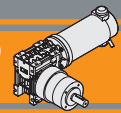

Dimensioni

Dimensions

ECWMP100/026/62...U

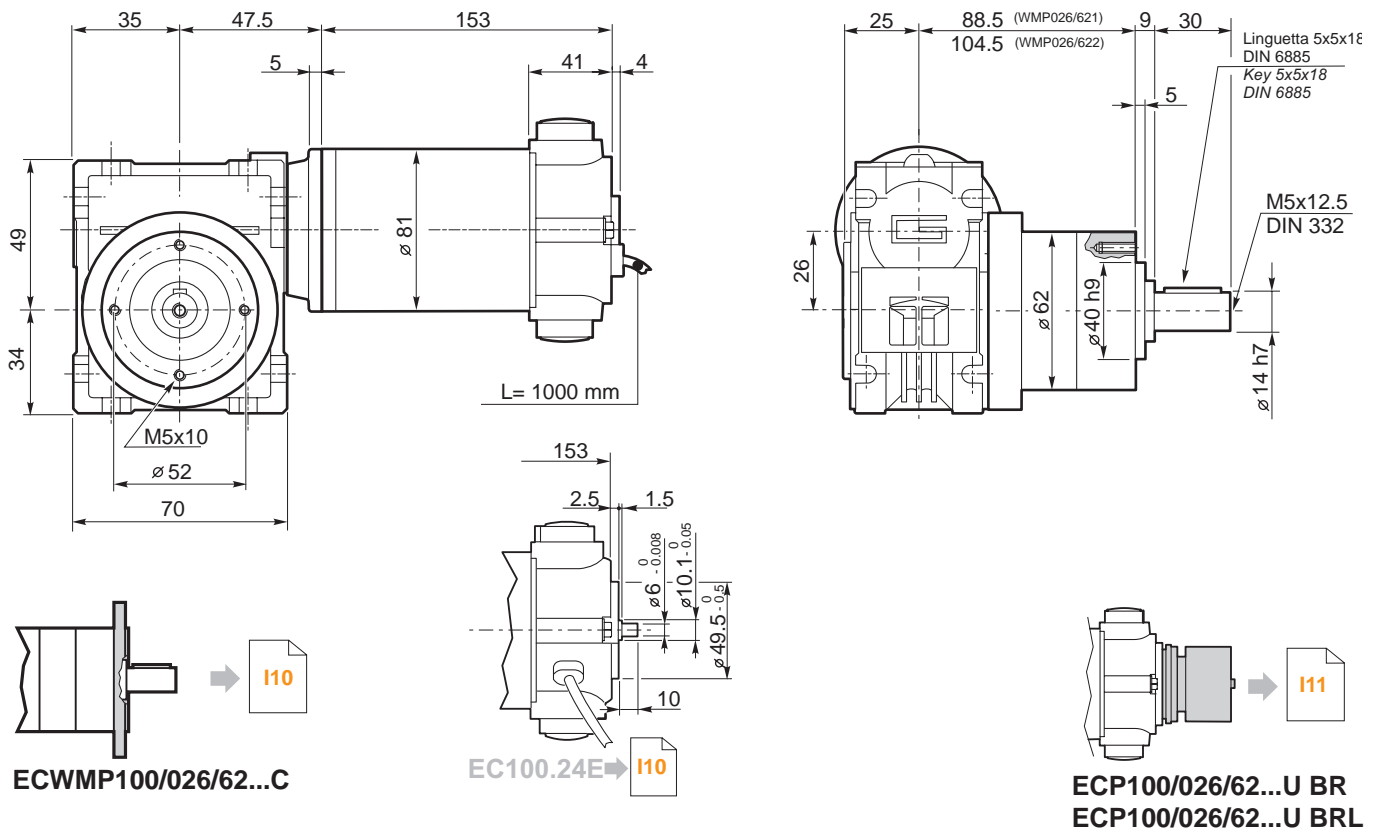

ECWMP100/030/81...U

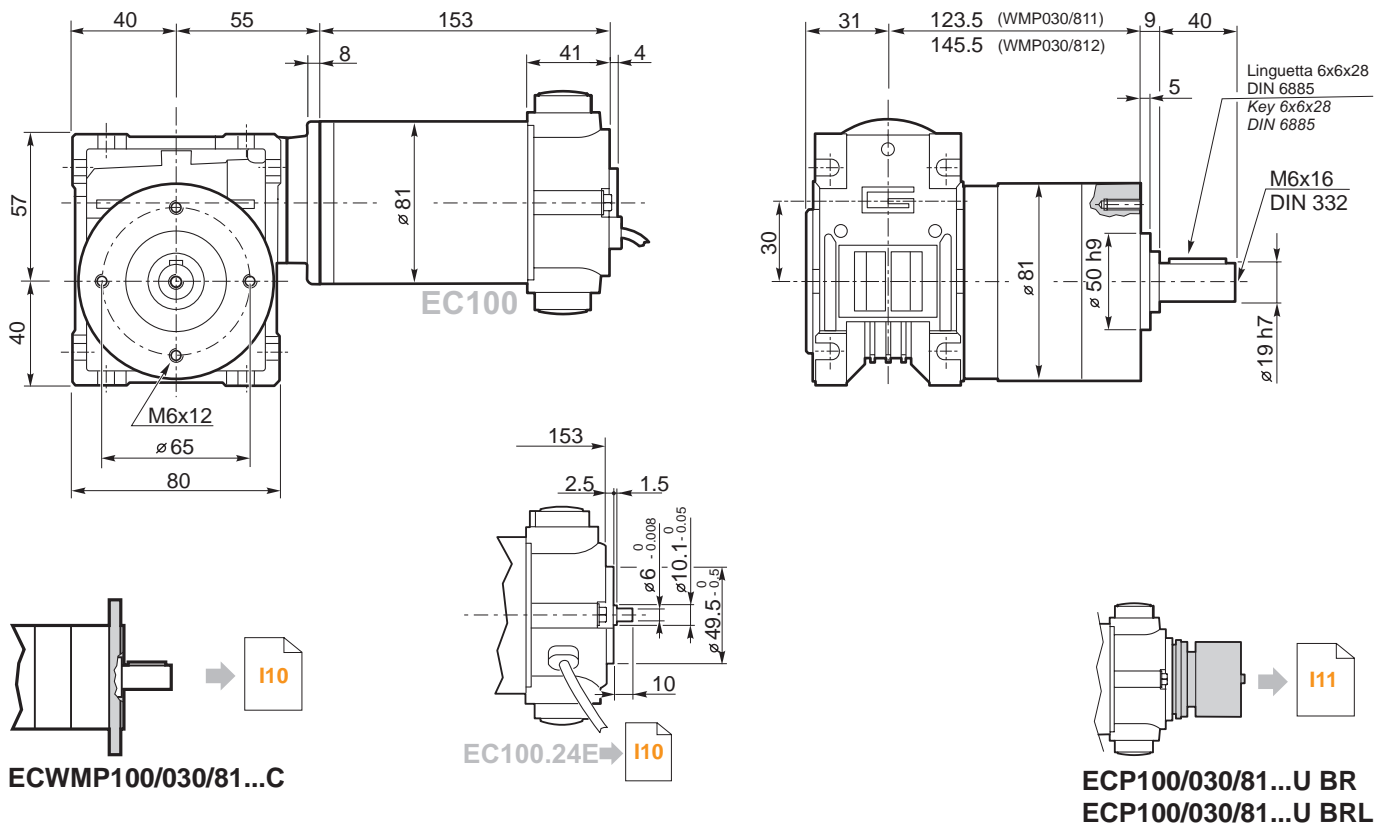

ECWMP

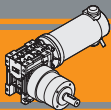

ECWMP

MOTORIDUTTORI CC COMBINATI A MAGNETI PERMANENTI IN FERRITE

FERRITE PERMANENT MAGNETS DC DOUBLE REDUCTION GEARMOTORS

Dimensioni

Dimensions

ECWMP180/026/62...U

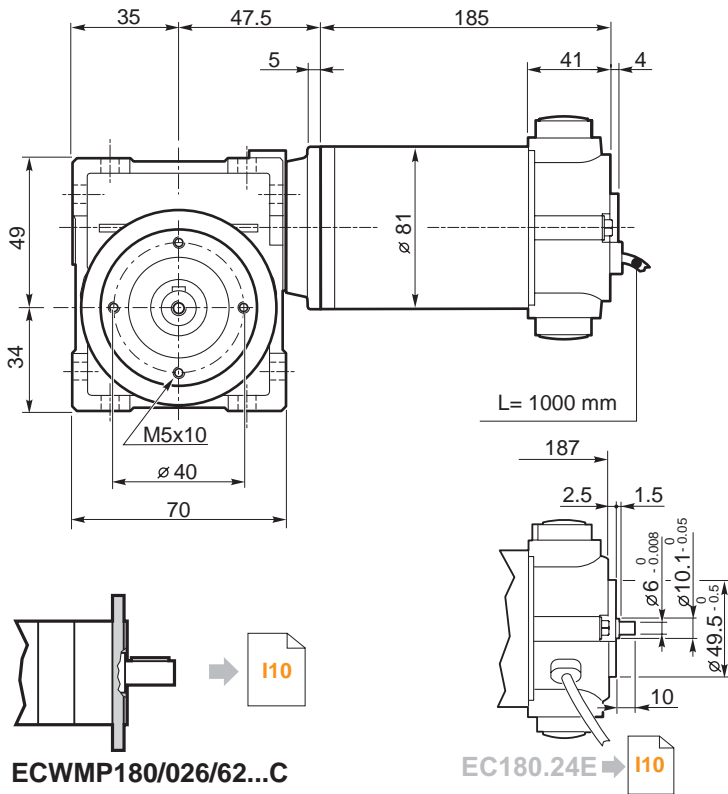

ECWMP180/026/62...C

EC180.24E → I10

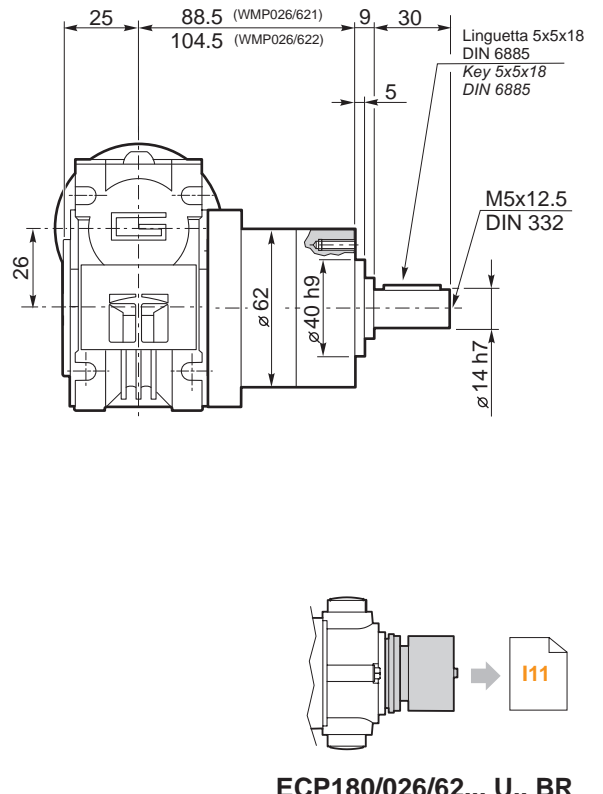

ECP180/026/62... U.. BR
ECP180/026/62... U.. BRL

ECWMP180/030/81...U

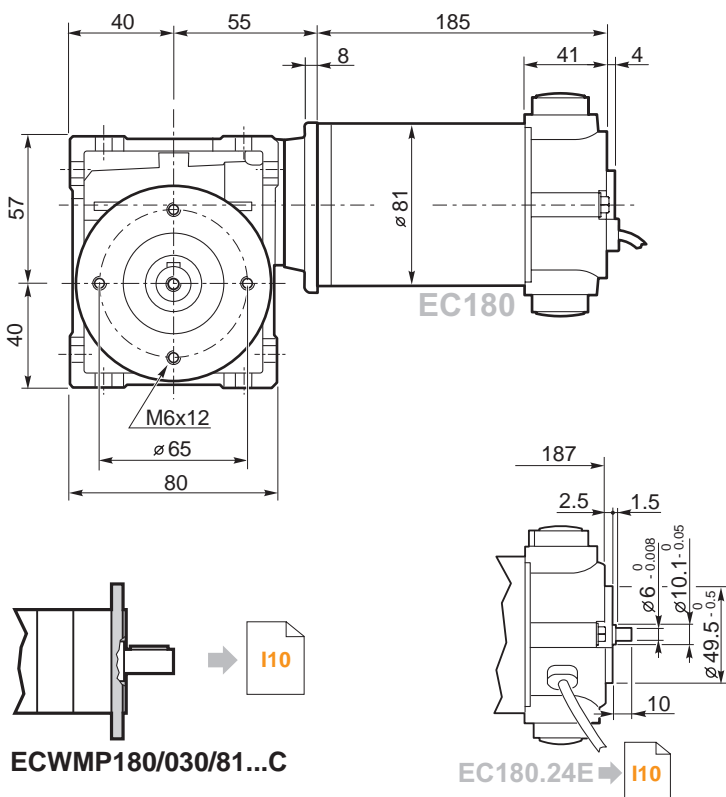

ECWMP180/030/81...C

EC180.24E → I10

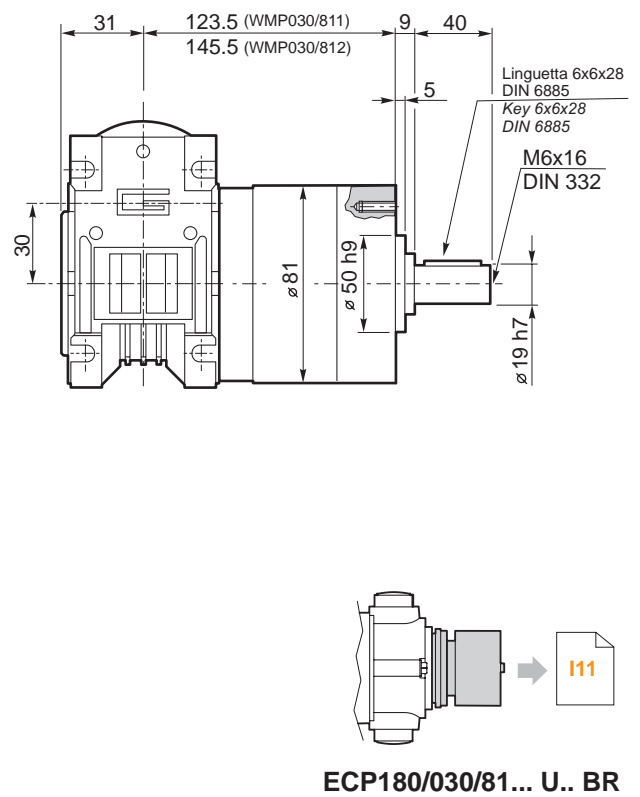

ECP180/030/81... U.. BR
ECP180/030/81... U.. BRL

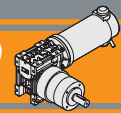

Dimensioni

Dimensions

ECWMP250/030/81...U

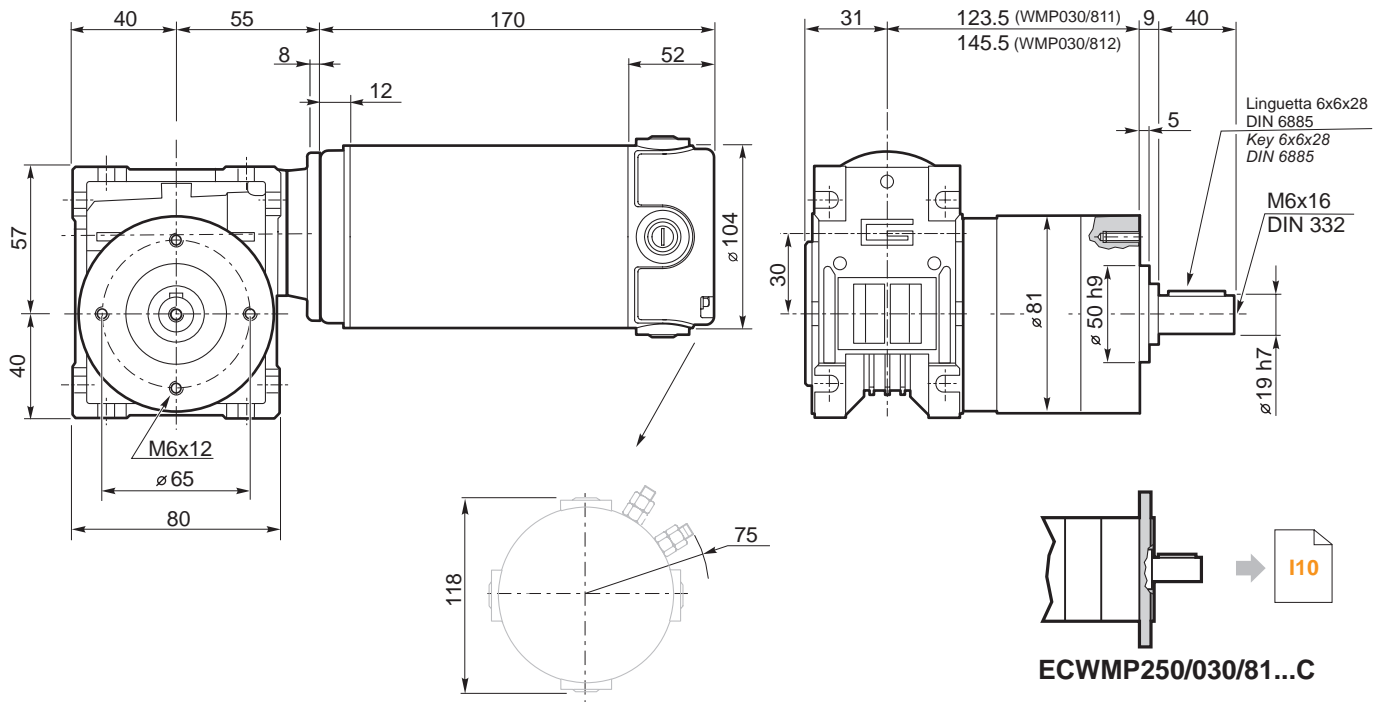

ECWMP350/030/81...U

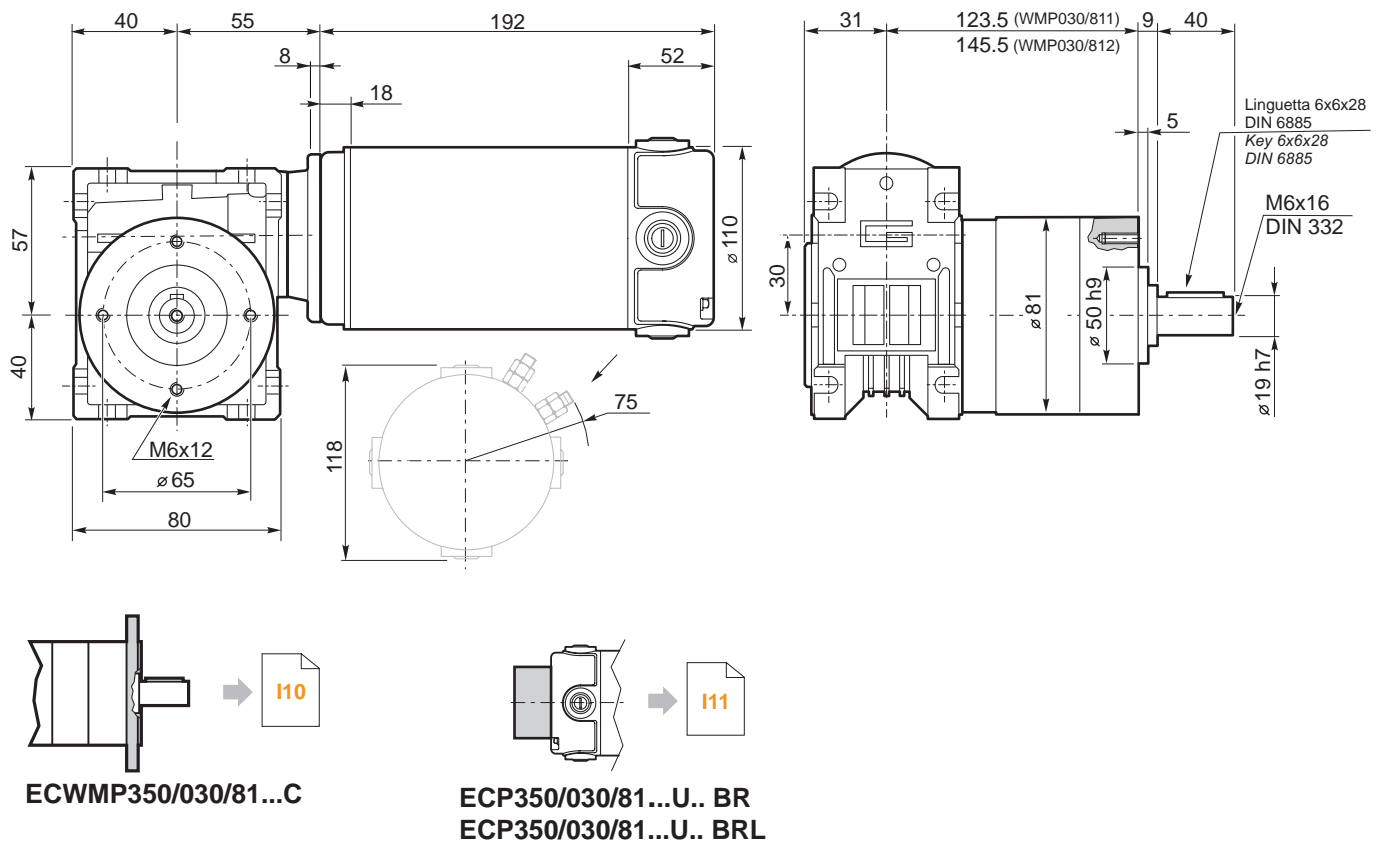

ECWMP

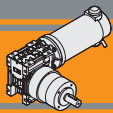

ECWMP

MOTORIDUTTORI CC COMBINATI A MAGNETI PERMANENTI IN FERRITE
FERRITE PERMANENT MAGNETS DC DOUBLE REDUCTION GEARMOTORS

Dimensioni

Dimensions

ECP100.24E
ECP180.24E

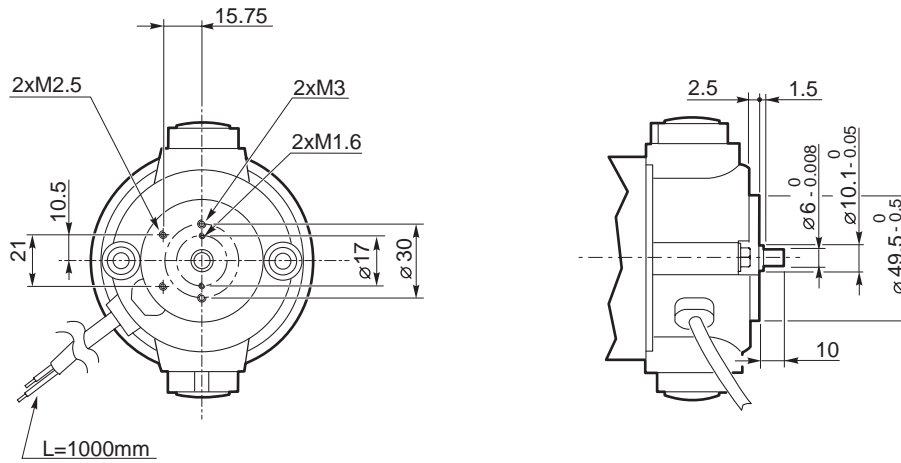

ECWMP.../.../... C... Flange uscita / Output flanges

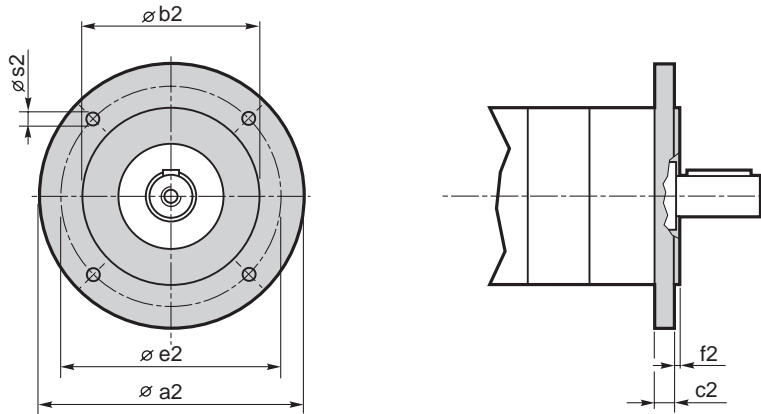

Dimensioni / Dimensions							
P	a2	b2	c2	e2	f2	s2	Flangia uscita Output flange
52	80	50 j7	9	65	2.5	M5	C80
	90	60 j7	9	75	2.5	5.5	C90
	105	70 j7	9	85	2.5	6.5	C105
	120	80 j7	9	100	3.0	6.5	C120
62	80	50 j7	9	65	2.5	M5	C80
	90	60 j7	9	75	2.5	5.5	C90
	105	70 j7	9	85	2.5	6.5	C105
	120	80 j7	9	100	3.0	6.5	C120
81	90	60 j7	9	75	2.5	M5	C90
	105	70 j7	9	85	2.5	M6	C105
	120	80 j7	9	100	3.0	6.5	C120

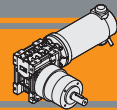

Dimensioni

Dimensions

Freno / Brake

ECWMP50/... U BR
ECWMP70/... U BR

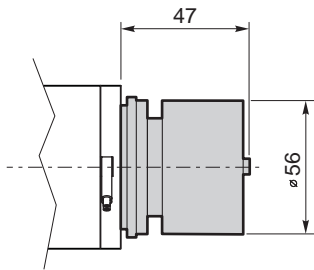

ECWMP100/... U BR
ECWMP180/... U BR

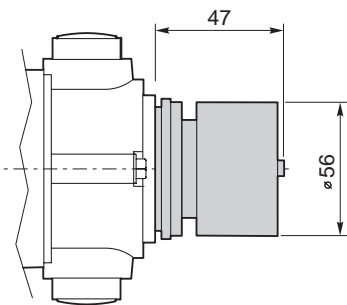

ECWMP350/... U BR
ECWMP600/... U BR

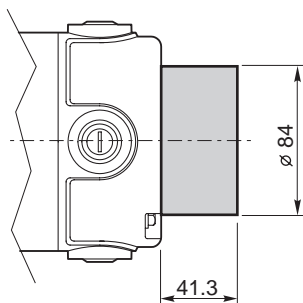

Freno con leva di sblocco / Brake with hand release

ECWMP50/... U BRL
ECWMP70/... U BRL

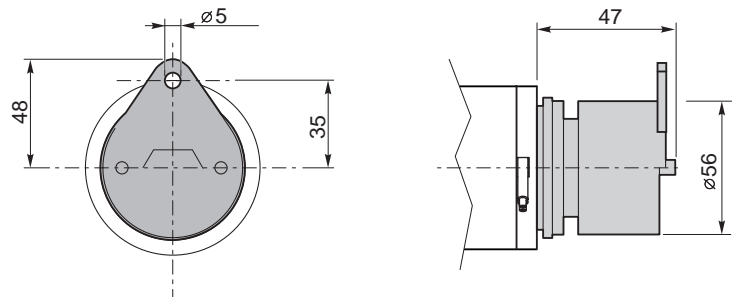

ECWMP100/... U BRL
ECWMP180/... U BRL

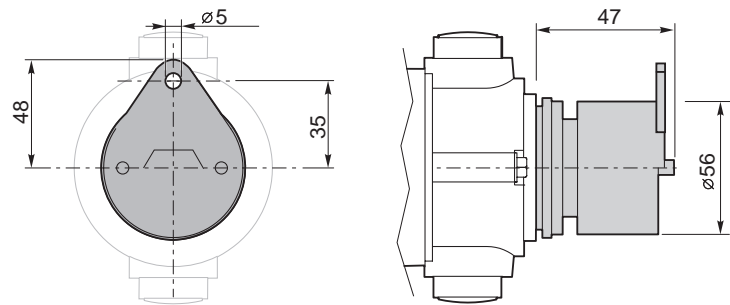

ECWMP350/... U BRL
ECWMP600/... U BRL

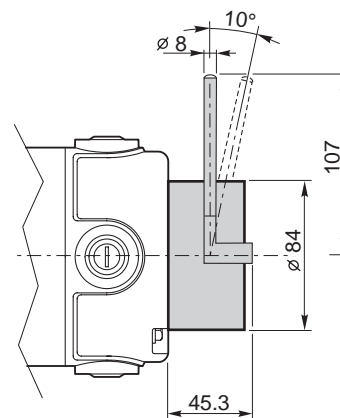

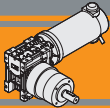

ECWMP

MOTORIDUTTORI CC COMBINATI A MAGNETI PERMANENTI IN FERRITE
FERRITE PERMANENT MAGNETS DC DOUBLE REDUCTION GEARMOTORS

Note/Notes



Azionamenti per motori CC DC motor controls





	Indice	Index	Pag. Page
PLN19-8	Schema dei collegamenti	<i>Main connection diagram</i>	L2
	Caratteristiche tecniche	<i>Technical features</i>	L2
	Dimensioni	<i>Dimensions</i>	L3
	Opzioni	<i>Options</i>	L3
PLN20 PLN40	Schema dei collegamenti	<i>Main connection diagram</i>	L4
	Caratteristiche tecniche	<i>Technical features</i>	L5
	Dotazioni	<i>Equipment</i>	L5
	Manuale	<i>User manual</i>	L5
	Dimensioni	<i>Dimensions</i>	L6
	GUIDA alla selezione dell'azionamento	<i>Drive selection GUIDE</i>	L7
	Note	<i>Note</i>	L8

Questa sezione annulla e sostituisce ogni precedente edizione o revisione. Qualora questa sezione non Vi sia giunta in distribuzione controllata, l'aggiornamento dei dati ivi contenuto non è assicurato. **In tal caso la versione più aggiornata è disponibile sul nostro sito internet www.transtecno.com**

*This section replaces any previous edition and revision. If you obtained this catalogue other than through controlled distribution channels, the most up to date content is not guaranteed. **In this case the latest version is available on our web site www.transtecno.com***



**AZIONAMENTO UNIDIREZIONALE PWM PER LA
REGOLAZIONE DI VELOCITA' DEI MOTORI A
CORRENTE CONTINUA A BASSA TENSIONE**

**LOW VOLTAGE SINGLE DIRECTION
PWM DC MOTORS CONTROL**

SCHEMA DEI COLLEGAMENTI - MAIN CONNECTION DIAGRAM

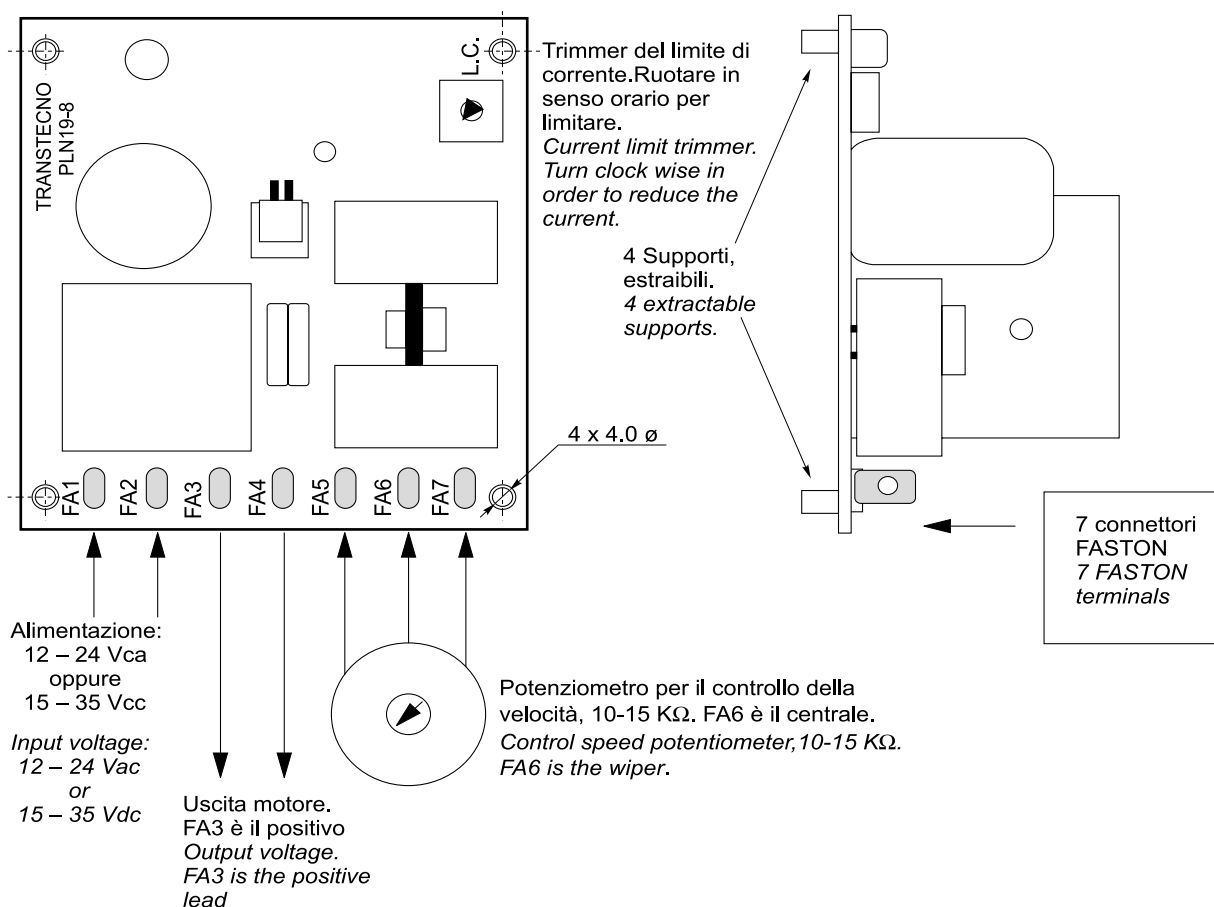

Attenzione: se si scollega il potenziometro con la scheda alimentata, il motore ruota alla velocità nominale.

Warning: if speed pot is disconnected when the board is powered, the motor runs at its maximum speed.

Caratteristiche tecniche

Technical features

- Alimentazione ai terminali FA1 e FA2:
12 - 24 Vca oppure 15 - 35 Vcc.
- Regolazione della velocità mediante potenziometro 10-15 KΩ.
- Trimmer di Limitazione della corrente, per adattare la scheda anche a motori di piccole potenze. Per limitare l'erogazione di corrente, ruotare in senso orario il trimmer.
- Uscita motore ai terminali FA3 e FA4, regolabile da 0 a Vcc MAX che è proporzionale alla tensione di ingresso. Con 35 Vcc di alimentazione, l'uscita MAX è circa 30 Vcc.
- Corrente di uscita (*): Massima corrente ammessa: 8 A in ambiente ventilato, servizio continuo.
- Peso: 0.120 Kg.
- Line voltage at terminals FA1 and FA2:
12 - 24 Vac or 15 - 35 Vdc.
- The speed of the drive is to be controlled by potentiometer, 10-15 KΩ.
- Current Limit trimmer, in order to suit the board for small motors. In order to limit the current, turn clock wise the trimmer.
- Output voltage from terminals FA3 and FA4, from 0 up to Vdc MAX which is proportional to the input voltage. With 35 Vdc input voltage, the max output voltage is about 30 Vdc.
- Output current (*): Maximum output current allowed: 8 A in a ventilated environment, continuous duty.
- Weight: 0.120 Kg.

Dimensioni

Dimensions

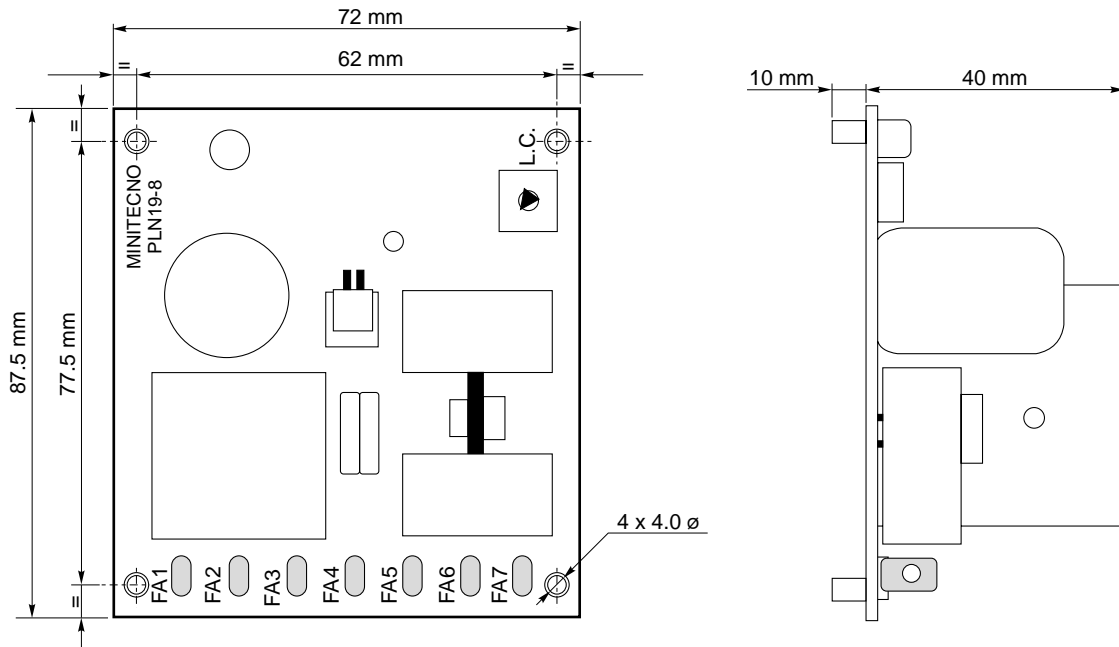

Opzioni

Options

1. Potenzimetro 10 kΩ
2. Supporto per montaggio su guida DIN

1. Speed potentiometer 10 kΩ
2. DIN mounting support

(*) il valore massimo di corrente motore deve essere utilizzato in **ambiente ventilato**. In ambienti non ventilati e per temperatura ambiente di 45 °C, ridurre la corrente motore massima a 4 A; servizio continuo.

(*) *the maximum output current value must be used in a **ventilated environment**. Derate the maximum output current down to 4 A if the environment is not ventilated and the temperature is about 45 °C; continuous duty.*



AZIONAMENTO BIDIREZIONALE PWM PER LA REGOLAZIONE DI VELOCITA' DEI MOTORI A CORRENTE CONTINUA A BASSA TENSIONE

LOW VOLTAGE BIDIRECTIONAL PWM DC MOTORS CONTROL

SCHEMA DEI COLLEGAMENTI - MAIN CONNECTION DIAGRAM

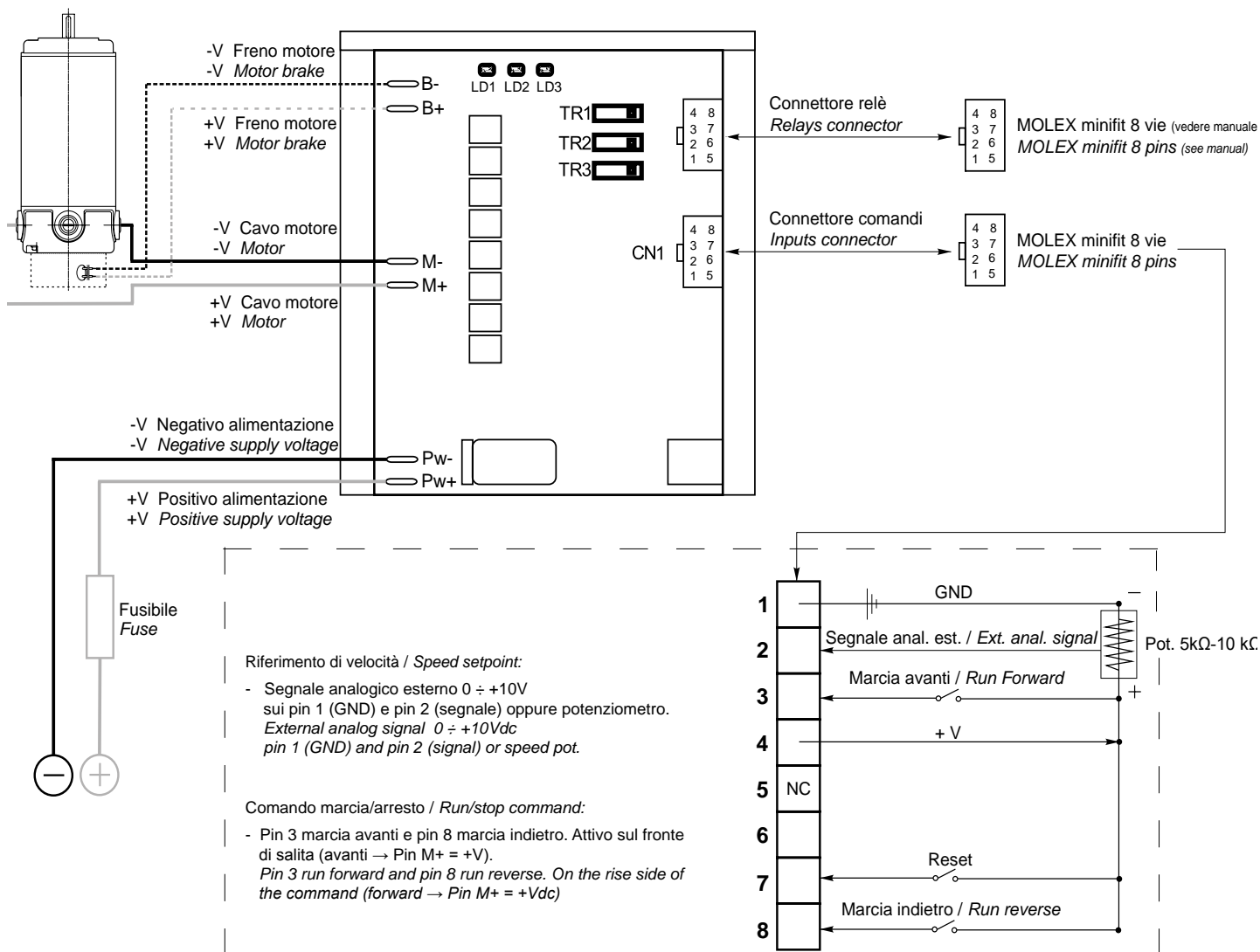
**Fusibile:**

150-200% della corrente motore. Max 3 volte la corrente nominale della scheda, con intervento entro pochi secondi.

Fuse:

150-200 % rated motor current. Max 3 times rated current of the drive (trip time in few seconds).

Trimmer multigiro:

TR1: Accelerazione: selezione da 0.5 a 10 sec.

TR2: Limite di corrente: riduce il limite di corrente nominale da 100% a circa 30% (corrente di picco 3 volte la corrente selezionata).

TR3: Decelerazione: selezione da 0.5 a 10 sec.

Multiturn trimmers:

TR1: Acceleration time: from 0.5 to 10 sec.

TR2: Current limitation: rated current limited from 100% to about 30% (peak current 3 times the selected limited current).

TR3: Deceleration time: from 0.5 to 10 sec.

LED:

LD1: Visualizza lo stato di funzionamento con limite di corrente attivo (il motore assorbe più della corrente selezionata e l'azionamento opera in limitazione).

LD2: Stato dell'azionamento: lampeggio veloce e continuo = funzionamento normale, lampeggio lento e codificato = presenza di un allarme

LD3: Segnalazione presenza alimentazione.

LED:

LD1: ON when the drive runs under current limitation (motor requires more than the rated current and drive supplies only limited current).

LD2: Status: quick continuous flash = drive ok, slow coded flash = fault).

LD3: Power ON



Caratteristiche tecniche

Technical features

- Scheda bidirezionale a transistor a ricircolo di corrente.
 - Selezionabili i seguenti parametri (mediante trimmer):
 - rampa di accelerazione: 0.5 - 10 sec
 - rampa di decelerazione: 0.5 - 10 sec
 - limite corrente 100%-30% circa
 - Temperatura di lavoro: 0°C / +40°C (allarme sotto zero)
 - Diagnostica tramite LED
 - Frequenza di commutazione: 16kHz
 - Dotata di coperchio
 - Velocità regolabile con potenziometro 5-10 kΩ o con segnale 0-10 Vcc
 - Limitazione della corrente regolabile
 - Sensore termico di protezione
- *Transistor bidirectional drive with regenerative current system.*
 - *Following settings can be adjusted (by built in trimmers):*
 - *acceleration ramp: 0.5 - 10 sec*
 - *deceleration ramp: 0.5 - 10 sec*
 - *current limit 100% - about 30%*
 - *Room temperature: 0°C / +40°C (alarm below zero)*
 - *LED for system diagnosis*
 - *Switching frequency: 16kHz*
 - *Covered*
 - *5-10 kΩ Speed pot. or 0-10 Vdc external signal for speed re-
gulation*
 - *Variable current limit*
 - *Thermal sensor for protection*

Modello Model number	Tensione di alimentazione DC input voltage [Vdc]	Tensione di uscita Motor voltage [Vdc]*	Corrente di uscita nominale DC load current [A]	Corrente di picco motore Maximum load current [A]**	Campo di alimentazione Power supply range [Vdc]
PLN20	12 ÷ 24	0 ÷ Vin	20	60 (4 sec)	10 ÷ 30
PLN40	12 ÷ 24	0 ÷ Vin	40	120 (4 sec)	10 ÷ 30

* L'azionamento riduce la tensione nominale di 1-2 Vcc. Il fenomeno è normale e fisiologico. Se serve ottenere 24 ÷ 12 Vcc in uscita sotto ogni condizione di carico, si suggerisce di sovralimentare di un paio di volt.

** Un timer impone il limite con un andamento temporale iperbolico, cioè quanta più corrente eroga e tanto meno è il tempo per il quale ciò è ammesso, prima che appunto la scheda vada in limitazione. Alla corrente di picco (x 3 volte quella nominale) la scheda funziona per pochi secondi.

* *The drive reduces the rated voltage of 1-2 Vdc. This is normal and physiological. If 24 ÷ 12 VDC output is required under all load conditions, it is advisable to supercharge a couple of volts.*

** *A timer imposes a limit with a temporary hyperbolic performance, which means the more current is requested, the less time is permitted with this current before the drive is limited. When the current reaches its peak (3 times the rated value) the drive will work for a few seconds.*

Dotazioni

Equipment

	PLN20 PLN40
Trimmer di selezione ACCEL, DECEL e LIMITE di CORRENTE / <i>Selection Trimmer ACCEL, DECEL, CURRENT LIMIT</i>	■
2 contatti: marcia avanti e marcia indietro / <i>2 contacts : forward and reverse</i>	■
Riferimento di velocità / <i>Speed setpoint reference</i>	■
3 LEDs di segnalazione / <i>3 LEDs signals</i>	■
Segnale di comando di eventuale freno negativo di stazionamento / <i>Command signal for possible negative electromagnetic brake</i>	■
Predisposizione per montaggio a libro e a zoccolo / <i>Arranged for 2 different ways of mounting</i>	■
Memorizzazione e segnalazione degli allarmi / <i>Memory storage and report of allarm</i>	■
2 ingressi digitali ausiliari / <i>2 auxiliary digital inputs</i>	■#
1 relè segnalazione allarmi / <i>Alarm output relays</i>	■

uno impegnato dal reset / *one comitted by reset*



Per approfondimenti si raccomanda di scaricare il manuale d'uso dal nostro sito www.transtecno.com alla pagina dei prodotti.

Please, download the user manual for more information from our web site www.transtecno.com from the product page.



AZIONAMENTO BIDIREZIONALE PWM PER LA
REGOLAZIONE DI VELOCITA' DEI MOTORI A
CORRENTE CONTINUA A BASSA TENSIONE

LOW VOLTAGE BIDIRECTIONAL
PWM DC MOTORS CONTROL

Dimensioni

Dimensions

PLN20

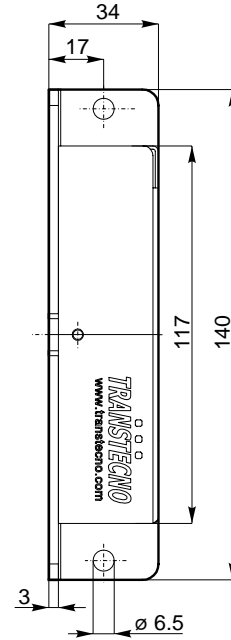
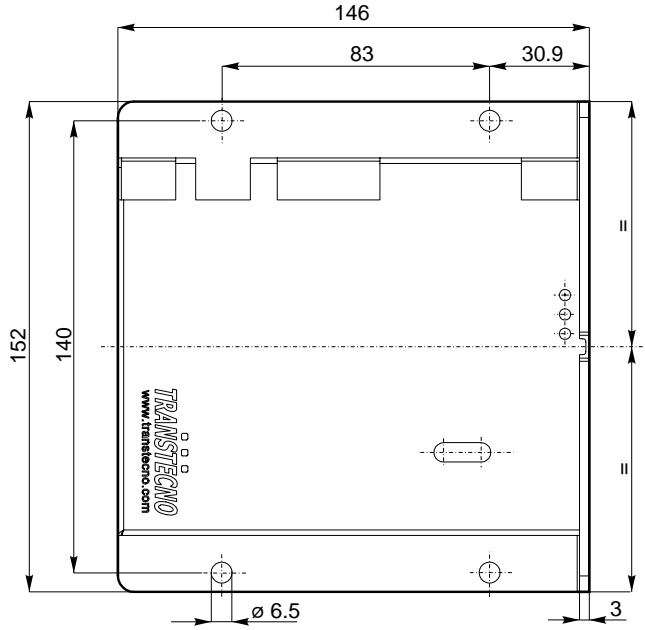

PLN40

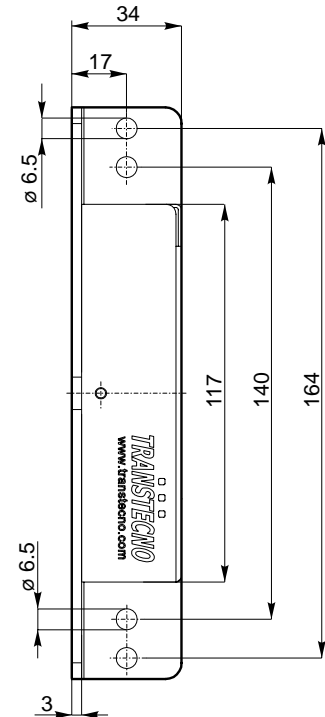
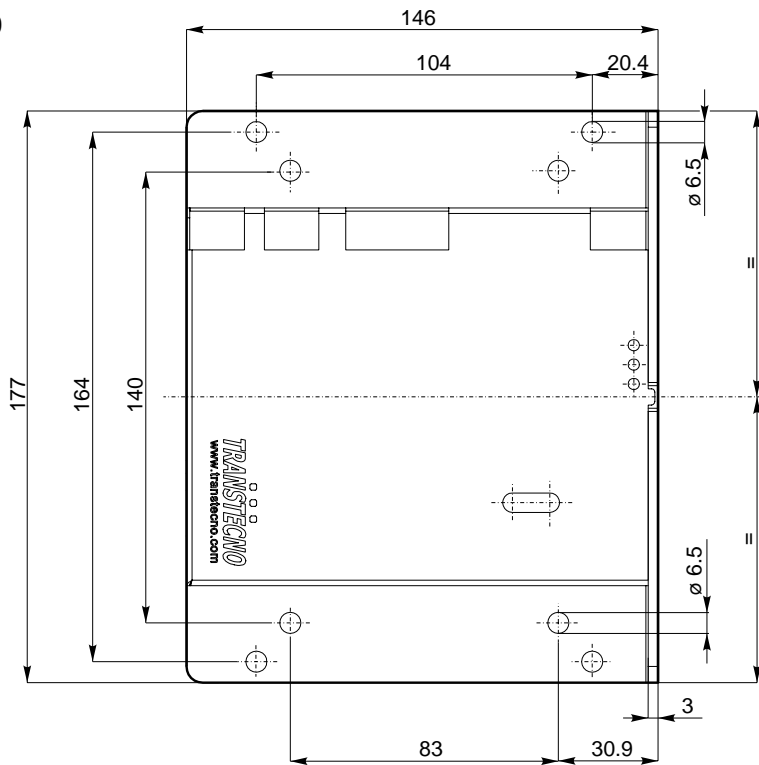



GUIDA alla selezione dell'azionamento

Drive selection GUIDE

Corrente di uso del motore	≤	Corrente nominale dell'azionamento
-------------------------------	---	---------------------------------------

<i>Real motor current</i>	≤	<i>Rated current of the drive</i>
-------------------------------	---	---------------------------------------

Attenzione: la reale corrente assorbita dal motore può essere diversa da quella indicata in targhetta.

PLN19-8 = max 6 A

PLN20 = max 22 A

PLN40 = max 44 A

Vedere sotto la tabella per esemplificazioni

Warning: the real absorbed current by the motor can be different from the one written on the nameplate.

PLN19-8 = max 6 A

PLN20 = max 22 A

PLN40 = max 44 A

See the table below for quick reference

Codice motore <i>Motor code</i>	Corrente motore <i>Motor current</i> S1	Scheda-Drive (servizio motore-motor duty) S1	Corrente motore <i>Motor current</i> S2	Scheda-Drive (servizio motore-motor duty) S2
EC020.120	3.2	PLN19-8 – PLN20	4	PLN19-8 – PLN20
EC020.240	1.5	PLN19-8 – PLN20	2	PLN19-8 - PLN20
EC035.120	5.2	PLN19-8 – PLN20	8	PLN20
EC035.240	2.6	PLN19-8 - PLN20	4	PLN19-8 - PLN20
EC050.120	6.8	PLN20	9.4	PLN20
EC050.240	3.4	PLN19-8 - PLN20	4.7	PLN19-8 - PLN20
EC070.120	8.4	PLN20	11.8	PLN20
EC070.240	4.2	PLN19-8 - PLN20	5.9	PLN19-8 - PLN20
EC100.120	12	PLN20	16.8	PLN20
EC100.240	6	PLN19-8 - PLN20	8.4	PLN20
EC100.24E	6	PLN19-8 - PLN20	8.4	PLN20
ND100.120	13.9	PLN20	19	PLN20
ND100.240	6.9	PLN20	9.0	PLN20
EC180.120	21.5	PLN20	30	PLN40
EC180.240	10.8	PLN20	15	PLN20
EC180.24E	10.8	PLN20	15	PLN20
ND180.120	20	PLN20	30	PLN40
ND180.240	10	PLN20	14	PLN20
EC250.120	30	PLN40	39	PLN40
EC250.240	15	PLN20	19.5	PLN20
EC350.120	42	PLN40	58.8	----
EC350.120BR				
EC350.240	21	PLN20	29.4	PLN40
EC350.240BR				
EC600.240	35.5	PLN40	47	PLN40
EC600.240BR				

PLN

**MA TRANSTECNO S.A.P.I. DE C.V.**

Av. Mundial # 176, Parque Industrial
JM Apodaca, Nuevo León,
C.P. 66600
MÉXICO
T +52 8113340920
info@transtecno.com.mx
www.transtecno.com.mx

**TRANSTECNO SRL**

Via Caduti di Sabbiuono, 11/D-E
40011 Anzola dell'Emilia (BO)
ITALY
T+39 051 64 25 811
F +39 051 73 49 43
sales@transtecno.com
www.transtecno.com

**HANGZHOU TRANSTECNO POWER TRANSMISSIONS CO LTD**

Changlian Road, Fengdu Industry zone,
Pingyao Town Yuhang Area,
Hangzhou, 311115 - CHINA
T +86 571 86 92 02 60
F +86 571 86 92 18 10
info-china@transtecno.com
www.transtecno.cn

**TRANSTECNO U.S.A. LLC**

5440 S.W. 156th Place Miami,
FL 33185 - USA
Tel: +1 (305) 220-4423
Fax: +1 (305) 220-5945
usaoffice@transtecno.com

**SALES OFFICE BRAZIL**

Rua Dr. Freire Alemão 155 / 402 - CEP. 90450-060
Auxiliadora Porto Alegre RS - BRAZIL
Tel: +55 51 3251 5447
Fax: +55 51 3251 5447
Mobile: +55 51 811 45 962
braziloffice@transtecno.com
www.transtecno.com.br

**TRANSTECNO SRL (Branch)**

Via Ferrari, 27/11 41043 Fraz. Corlo
Formigine (MO) - ITALY
Tel. +39 059 55 75 22
Fax +39 059 55 74 39
sales@transtecno.com

**TRANSTECNO B.V.**

De Stuwdam, 43
3815 KM Amersfoort - NEDERLAND
Tel: +31(0) 33 45 19 505
Fax: +31(0) 33 45 19 506
info@transtecno.nl
www.transtecno.nl

**SALES OFFICE FRANCE**

12 Impasse des Mûriers
38300 Ruy - FRANCE
Tel: +33 (0) 6 85 12 09 87
Fax-Italy: +39 051 733 904
franceoffice@transtecno.com
www.transtecno.fr

**SALES OFFICE GUANGZHOU**

Room 401A, LeTian Building, No.188 TangAn Road,
Tianhe District, Guangzhou City, 510665 - CHINA
Tel: +86 20 387 760 57
Fax: +86 20 387 761 27
guangzhouoffice@transtecno.com

**SALES OFFICE INDIA**

A/10, Anagha, S.N. Road, Mulund (W) Mumbai
400080 - INDIA
Tel: +91 9820614698
Fax-Italy: +39 051 733 904
indiaoffice@transtecno.com

**SALES OFFICE SOUTH KOREA**

D-304 Songdo BRC Smart Valley 30, Songdomirae-ro,
Yeonsu-gu, Incheon, 406-840 - KOREA
Tel: +82 70 8288 2107
Fax: +82 32 815 2107
Mobile: +82 10 5094 2107
koreaoffice@transtecno.com

**SALES OFFICE OCEANIA**

Unit 3, 18-24 Ricketts Road, Mount Waverley 3149
Victoria - AUSTRALIA
Tel: +61 9544 8005
Fax: +61 9543 8005
Mobile: +61 0438 060 997
oceaniaoffice@transtecno.com
www.transtecno.com.au