

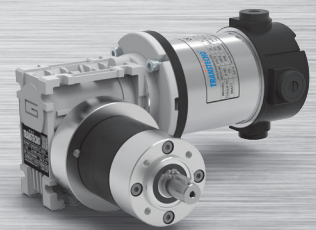

MINI TECNO

small but strong

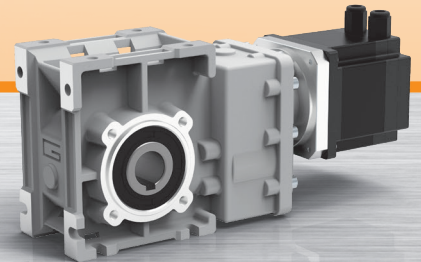
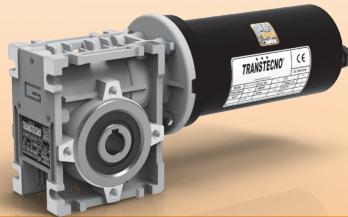
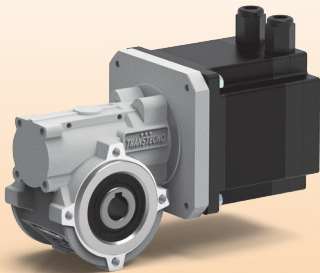
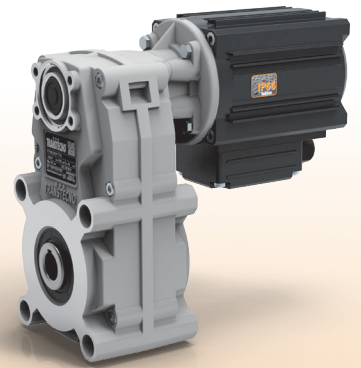
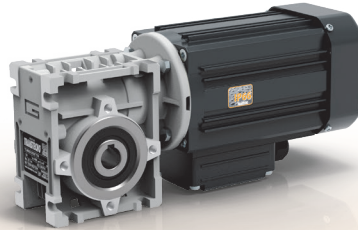
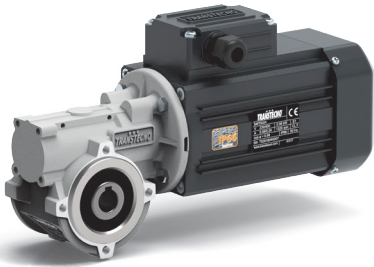

	Indice	Index	Pag. Page
	I Introduzione	Introduction	I1
	II Motoriduttori a vite senza fine CL	Wormgearmotors CL	II1
AC	A Motoriduttori CA	AC Gearmotors	A-A1
DC	B Motoriduttori CC	DC Gearmotors	B-A1
BLDC	A Motoriduttori Brushless CC	Brushless DC Gearmotors	C-A1

Questo catalogo annulla e sostituisce ogni precedente edizione o revisione.
 Ci riserviamo inoltre il diritto di apportare modifiche senza preavviso.
 La versione più aggiornata è disponibile sul sito
www.transtecno.com

*This catalogue supersedes any previous edition and revision.
 We reserve the right to implement modifications without notice.
 The most updated version is available on our website
www.transtecno.com*



Introduzione
Introduction



Indice	Index	Pag. Page
Generalità	<i>General information</i>	12
Velocità entrata	<i>Input speed</i>	12
Rapporto di riduzione	<i>Gear ratio</i>	12
Velocità in uscita	<i>Output speed</i>	12
Coppia richiesta	<i>Requested torque</i>	12
Coppia nominale	<i>Nominal torque</i>	13
Coppia trasmessa	<i>Output torque</i>	13
Rendimento del riduttore a vite senza fine	<i>Worm gearbox efficiency</i>	13
Reversibilità e irreversibilità	<i>Reversibility and irreversibility</i>	14
Potenza in entrata	<i>Input power</i>	14
Fattore di servizio	<i>Service factor</i>	15
Carico radiale	<i>Radial load</i>	16
Carico assiale	<i>Axial load</i>	16
Scelta dei motoriduttori	<i>Selecting the gearmotors</i>	16
Installazione e verifiche	<i>Installation and inspection</i>	18
Applicazioni critiche	<i>Critical applications</i>	18

Questa sezione annulla e sostituisce ogni precedente edizione o revisione. Qualora questa sezione non Vi sia giunta in distribuzione controllata, l'aggiornamento dei dati ivi contenuto non è assicurato. **In tal caso la versione più aggiornata è disponibile sul nostro sito internet www.transtecno.com**

This section replaces any previous edition and revision. If you obtained this catalogue other than through controlled distribution channels, the most up to date content is not guaranteed. In this case the latest version is available on our web site www.transtecno.com

Generalità

Per avere una migliore comprensione degli argomenti e dei dati esposti in questo catalogo proponiamo la simbologia utilizzata corredandola delle informazioni di base per giungere ad una corretta selezione dei motoriduttori e variatori.

Information in this manual is provided with symbols in order to understand the subject matter and data. These symbols are intended to aid the user in selecting the right gearmotors and variators.

General information

Velocità entrata

n_1 [min⁻¹]

Input speed

Rappresenta la velocità riferita al tipo di motorizzazione prescelta ed è applicata in entrata al riduttore.

This is the input speed at the gearbox related to the type of drive unit selected.

Per selezioni a velocità diverse da quelle riportate consultare il ns. Servizio Tecnico.

When different speeds are required, contact our Technical Service.

Rapporto di riduzione

i

Gear ratio

È una grandezza adimensionale ed è in funzione del numero dei denti degli ingranaggi interni al riduttore.

This value is strictly related to the size and number of teeth gears inside the gearbox.

Nei riduttori a vite senza fine si ottiene dividendo il numero di denti della corona per il numero dei filetti (Z) della vite senza fine.

This value is obtained in wormgearboxes by dividing the number of wheel teeth by the number of starts (Z) of the worm.

Dai dati di catalogo si può ottenere con la relazione:

From the data given in the catalogue, the value can be calculated using the following formula:

$$i = \frac{n_1}{n_2}$$

Velocità in uscita

n_2 [min⁻¹]

Output speed

È la velocità risultante sull' asse di uscita del riduttore e viene ricavata dalla relazione precedente:

This is the gearbox output speed calculated using the formula given above:

$$n_2 = \frac{n_1}{i}$$

Coppia richiesta

Mr_2 [Nm]

Requested torque

È la coppia richiesta dall'applicazione ed è indispensabile per la selezione di una motorizzazione.

This is the torque needed for the application and must be known when selecting a drive system. It can either be provided by the user or calculated according to the application data (if provided).

Essa può essere comunicata dall'utente oppure calcolata in base ai dati di applicazione (se forniti).

(if provided).

Coppia nominale

Mn₂ [Nm]

Nominal torque

Rappresenta la coppia in uscita trasmissibile dal riduttore in base alla velocità in entrata n_1 e al rapporto di riduzione i . Essa è calcolata in base ad un servizio con carico continuo uniforme corrispondente ad un fattore di servizio uguale a 1. Questo valore non è riportato nel presente catalogo ma può essere ricavato approssimativamente con la seguente relazione fra M_2 (coppia trasmessa) e sf (fattore di servizio):

This is the output torque that can be transmitted by the gearbox according to input speed n_1 and gear ratio i . It is calculated based on service with a continuous steady load corresponding to a service factor equal to 1. This value is not given in the catalogue but can be calculated approximately with the following formula between M_2 (output torque) and sf (service factor):

$$Mn_2 = M_2 \cdot sf$$

Coppia trasmessa

M₂ [Nm]

Output torque

È la coppia trasmessa in uscita al riduttore. Dipende dalla potenza P_1 del motore installato, dal numero di giri in uscita n_2 e dal rendimento dinamico Rd e può essere calcolata con la relazione:

This is the gearbox's output torque. It is strictly related to power P_1 of the motor installed, output rpm n_2 and dynamic efficiency Rd . It can be calculated with the following formula:

$$M_2 = \frac{9550 \cdot P_1 \cdot Rd}{n_2}$$

oppure:
or:

$$M_2 = \frac{9550 \cdot P_2}{n_2}$$

dove:
where:

$$P_2 = P_1 \cdot Rd$$

Rendimento del riduttore a vite senza fine

Rd; Rs

Worm gearbox efficiency

I calcoli delle prestazioni sono stati effettuati in base al rendimento dinamico Rd dei riduttori (valore ottimale che si raggiunge nel funzionamento a regime dopo rodaggio).

Efficiency is calculated based on dynamic efficiency Rd of the gearboxes (optimal value reached when running at normal speed after the break in period).

Nei riduttori combinati, il rendimento complessivo è dato dal prodotto dei rendimenti dei due riduttori, considerando però che nel secondo riduttore il rendimento dovrà essere valutato in base alla ridotta velocità in entrata ottenuta dividendo n_1 per il rapporto i del primo riduttore.

In combination gearboxes, overall efficiency is obtained from the combined efficiency of the two gearboxes. However, keep in mind that efficiency of the second gearbox should be determined according to the reduced input speed obtained by dividing n_1 by ratio i of the first gearbox.

È opportuno considerare che nei riduttori a vite senza fine si ha anche un valore di rendimento statico Rs , presente in fase di avviamento, che declassa sensibilmente la coppia risultante per cui influenza in modo determinante la scelta di motorizzazioni destinate ad applicazioni intermittenti (es. sollevamenti).

It is important to remember that wormgearboxes also have static efficiency value Rs present at start-up. This value notably reduces the resulting torque. As a result, it must be taken into consideration when selecting drive systems for intermittent operations (e.g. lifting) as it is a determinant factor.

Il valore dei rendimenti dinamico e statico dei riduttori a vite senza fine sono riportati nella tabella a pag. N4.

Dynamic and static efficiency of wormgearboxes are given in the table on page N4.

Nei riduttori ad ingranaggi CMG e CMB il rendimento medio è del 94%.

On helical gearboxes CMG and CMB the average efficiency is 94%.

Nei motovariatori il rendimento assume un valore di 0.85 alla velocità massima e decresce fino a 0.7 alla velocità minima.

Efficiency is 0.85 at the highest speed decreasing to 0.7 at the lowest speed in motovariators.

Reversibilità e irreversibilità

Reversibility and irreversibility

La diretta conseguenza del rendimento (statico e dinamico) è la reversibilità del riduttore a vite senza fine che consiste nella possibilità di fare ruotare l'albero entrata tramite l'applicazione di una torsione più o meno accentuata sull'albero uscita.

L'impossibilità o la difficoltà ad effettuare l'azione sopra descritta, determina il grado di reversibilità (o irreversibilità) di un riduttore.

Questa caratteristica, molto significativa nei riduttori a vite senza fine, è influenzata da molteplici fattori quali angolo d'elica (quindi rapporto di trasmissione), lubrificazione, temperatura, finitura superficiale della vite senza fine, presenza di vibrazioni, ecc.

In applicazioni dove sono presenti delle traslazioni è necessario garantire una elevata reversibilità onde evitare che le inerzie delle masse in movimento possano determinare punte di carico inammissibili sugli organi di trasmissione.

In applicazioni dove è richiesto un non ritorno del carico (es. sollevamenti o nastri trasportatori inclinati) in assenza di un freno motore è necessario scegliere un riduttore caratterizzato da un elevato grado di irreversibilità.

Desideriamo comunque evidenziare che la garanzia assoluta di non ritorno è data esclusivamente dall'installazione di un motore autofrenante o di un altro dispositivo frenante esterno.

La tabella sottostante riporta a titolo puramente indicativo i vari gradi di reversibilità/irreversibilità nei riduttori a vite senza fine in funzione del rendimento dinamico Rd e statico Rs.

Reversibility of the wormgearbox is the direct consequence of efficiency (static and dynamic). This determines whether or not the input shaft can be rotated by applying a certain torque on the output shaft.

Whether or not this can be done and how difficult it actually is to do determine the degree of reversibility (or irreversibility) of a gearbox.

This feature, quite significant in wormgearboxes, is affected by numerous factors including the helix angle (therefore drive ratio), lubrication, temperature, surface finish of the worm, vibrations, etc...

In applications that include translations, high reversibility must be guaranteed to prevent inertia of the moving parts from creating unacceptable load peaks on the drive parts.

In applications that require non-return of the load (e.g. lifting or inclined conveyor belts) a gearbox with high irreversibility must be chosen when a motor-brake unit is not present.

However, we would like to point out that non-return can be totally assured only by installing a self-braking motor or other external braking device.

The table below is provided for reference purposes only. It contains the various degrees of reversibility/irreversibility of wormgearboxes in relation to dynamic Rd and static Rs efficiency.

Rd	Reversibilità e irreversibilità dinamica	Dynamic reversibility and irreversibility
> 0.6	Reversibilità dinamica	Dynamic reversibility
0.5 - 0.6	Reversibilità dinamica incerta	Uncertain dynamic reversibility
0.4 - 0.5	Buona irreversibilità dinamica	Good dynamic irreversibility
<0.4	Irreversibilità dinamica	Dynamic irreversibility
Rs	Reversibilità e irreversibilità statica	Static reversibility and irreversibility
> 0.55	Reversibilità statica	Static reversibility
0.5 - 0.55	Reversibilità statica incerta	Uncertain static reversibility
<0.5	Irreversibilità statica	Static irreversibility

Potenza in entrata

P_1 [kW]

Input power

È la potenza motore applicata in entrata al riduttore e riferita alla velocità n_1 .

Può essere calcolata come segue:

This is the power applied by the motor at the gearbox input in reference to speed n_1 .

It can be calculated with the following formula:

$$P_1 = \frac{M_2 \cdot n_2}{9550 \cdot Rd}$$

Fattore di servizio

sf

Service factor

È una grandezza adimensionale che indica il sovradimensionamento da applicare ad una determinata motorizzazione per garantire la resistenza agli urti e la durata richiesta.

Le tabelle di catalogo offrono una vasta scelta di motorizzazioni con fattori di servizio differenziati che possono soddisfare la maggior parte delle applicazioni più o meno gravose.

Per una corretta interpretazione dei valori del fattore di servizio sf riportati a fianco di ogni selezione proposta, riportiamo nelle tabelle seguenti i valori indicativi attribuiti alle classi di carico A, B, C e alla durata di funzionamento giornaliero h/d e al numero di avviamenti/ora.

Definendo la classe di carico a cui riferire l'applicazione, si ricercherà nella tabella il corrispondente valore di sf da utilizzare nella scelta della motorizzazione più idonea.

This value indicates how a certain drive system is to be over-sized in order to assure the requested service and stand up to shocks.

The tables given in the catalogue offer a wide range of drive systems with different service factors able to satisfy most types of applications. To correctly understand service factor values sf given for each item, approximate values for load classes A, B and C along with the number of hours of daily operation h/d and number of start-ups/hours need to be known.

Once the load class required for the application has been determined, locate corresponding value sf to be used when selecting the most suitable drive system.

A - Uniforme	$fa \leq 0.3$
B - Medio	$fa \leq 3$
C - Forte	$fa \leq 10$

A - Uniform	$fa \leq 0.3$
B - Moderate shocks	$fa \leq 3$
C - Heavy shocks	$fa \leq 10$

$fa = \frac{Je}{Jm}$

- Je (kgm²) momento d'inerzia esterno ridotto all'albero motore.
- Jm (kgm²) momento d'inerzia motore.

Se $fa > 10$ interpellare il ns. Servizio Tecnico.

$fa = \frac{Je}{Jm}$

- Je (kgm²) moment of reduced external inertia at the drive-shaft.
- Jm (kgm²) moment of inertia of motor.

If $fa > 10$ call our Technical Service.

A Classe di carico / Load class
Carico uniforme / Uniform load

sf										
h/d	n. avviamenti/ora / n. start-up/hour									
	2	4	8	16	32	63	125	250	500	
4	0.8	0.8	0.9	0.9	1.0	1.1	1.1	1.2	1.2	
8	1.0	1.0	1.1	1.1	1.3	1.3	1.3	1.3	1.3	
16	1.3	1.3	1.3	1.3	1.5	1.5	1.5	1.5	1.5	
24	1.5	1.5	1.5	1.5	1.8	1.8	1.8	1.8	1.8	

B Classe di carico / Load class
Carico con urti moderati / Moderate shock load

sf										
h/d	n. avviamenti/ora / n. start-up/hour									
	2	4	8	16	32	63	125	250	500	
4	1.0	1.0	1.0	1.0	1.3	1.3	1.3	1.3	1.3	
8	1.3	1.3	1.3	1.3	1.5	1.5	1.5	1.5	1.5	
16	1.5	1.5	1.5	1.5	1.8	1.8	1.8	1.8	1.8	
24	1.8	1.8	1.8	1.8	2.2	2.2	2.2	2.2	2.2	

C Classe di carico / Load class
Carico con urti forti / Heavy shock load

sf										
h/d	n. avviamenti/ora / n. start-up/hour									
	2	4	8	16	32	63	125	250	500	
4	1.3	1.3	1.3	1.3	1.5	1.5	1.5	1.5	1.5	
8	1.5	1.5	1.5	1.5	1.8	1.8	1.8	1.8	1.8	
16	1.8	1.8	1.8	1.8	2.2	2.2	2.2	2.2	2.2	
24	2.2	2.2	2.2	2.2	2.5	2.5	2.5	2.5	2.5	

Esempio applicazione:

Nastro trasportatore attribuibile alla classe di carico B (**carico con urti moderati**) e previsto per una durata di funzionamento giornaliero (h/d) di **16** ore e con **8** avviamenti/ora. Dalla tabella rileviamo **sf = 1.5**

Application example:

Conveyor belt assigned to load class B (**moderate shock load**), to be run **16** hours a day (h/d) with **8** start-ups/hour. The following value is obtained from the table **sf = 1.5**

Carico radiale

R; R₂ [N]

Radial load

L'applicazione sull'albero in uscita del riduttore di pignoni, pulegge, ecc. determina delle forze radiali che debbono necessariamente essere considerate per evitare sollecitazioni eccessive con il rischio di danneggiamenti del riduttore stesso.

Il calcolo del carico radiale esterno R agente sull'albero del riduttore può essere determinato come segue:

Pinions, pulleys, etc applied on the output shaft of the gearboxes create radial forces that must be taken into consideration to avoid excessive stress risking damage to the gearbox itself.

External radial load R that acts on the gearbox shaft can be calculated as follows:

$$R = \frac{2000 \cdot M_2 \cdot kr}{d} \leq R_2$$

dove:

d [mm] diametro primitivo del pignone o della puleggia

kr coefficiente riferito al tipo di trasmissione:

kr = 1.4 ruota per catena

kr = 1.1 ingranaggio

kr = 1.5 - 2.5 puleggia per cinghia a V

where:

d [mm] diameter of the pinion or pulley

kr coefficient in relation to type of transmission:

kr = 1.4 sprocket wheel

kr = 1.1 gear

kr = 1.5 - 2.5 pulley for V belts

È opportuno evidenziare che i valori di R₂ sono riferiti a carichi agenti sulla mezzeria dell'albero lento (considerando l'albero sporgente) per cui il confronto dovrà essere effettuato nelle medesime condizioni.

Keep in mind that values R₂ refer to loads that act on the center-line of the output shaft (considering the shaft protrudes). As a result, the value should be compared under the same conditions.

Carico assiale

A; A₂ [N]

Axial load

A volte, unitamente al carico radiale, può essere presente anche una forza A che agisce assialmente sull'albero uscita; in questo caso considerare che il carico assiale ammissibile A₂ sull'albero è da considerare:

At times, along with the radial load, force A may be present that acts axially on the output shaft. In this case, keep in mind allowable axial load A₂ that can be applied on the shaft is:

$$A_2 = R_2 \cdot 0.2$$

Nel caso in cui il valore del carico assiale A agente sull'albero risultasse superiore ad A₂ contattate il ns. Servizio Tecnico.

If axial load A that acts on the shaft is greater than A₂, contact the Technical Service.

Scelta dei motoriduttori

Selecting the gearmotors

Per la scelta di un motoriduttore è necessario seguire la seguente procedura.

To select the required gearmotor perform the procedure below:

1. Per l'applicazione desiderata ricavare il fattore di servizio sf dalle tabelle a pag. A5 in base alla classe di carico, alle ore di funzionamento giornaliere e al numero di avviamenti orari.

1. Determine the service factor sf for the desired application by referring to the charts given on page A5. This is to be done by considering the class of load, the operational hours/day and the number of start-ups/ hour.

2. Se si conosce la potenza motore P₁ [kW] richiesta, passare al punto 3); se è nota la coppia in uscita M₂ richiesta è necessario calcolare la potenza motore P₁ con la formula:

2. If the required motor power output P₁ [kW] is known, go to item 3); if the required output torque M₂ is known, determine motor output P₁ by using the following formula:

$$P_1 = \frac{M_2 \cdot n_2}{9550 \cdot Rd}$$

dove Rd è il rendimento dinamico e n₂ il numero di giri richiesti in uscita al motoriduttore.

where Rd stands for the dynamic efficiency and n₂ indicates the required output rpm of the gearmotor.

3. Nelle tabelle dei dati tecnici ricercare la motorizzazione in cui sia P_1 maggiore o uguale a P e con riferimento ad una velocità n_2/n_{2max} prossima a quella desiderata, scegliere la motorizzazione in cui il fattore di servizio sf indicato risulta uguale o superiore a quello ricavato al punto 1).

3. Use the specification chart to search for the power unit where P_1 is greater than or equal to P with a speed n_2/n_{2max} that approximates the desired one. Choose a power unit where the indicated service factor sf is equal to or greater than that calculated at point 1).

ECM

P_1 [W]	n_2 [min ⁻¹]	M_2 [Nm]	sf	i		Versione motore Motor version
140						
(3000 min ⁻¹)	600	2.0	5.0	5	ECM100/026	120/240/24E
	400	2.9	3.8	7.5		
	300	3.8	2.9	10		
	200	5.5	2.0	15		
	150	7.1	1.5	20		
	100	10	1.2	30		
	75	12	0.9	40		
	60	14	0.7	50		
	50	13	0.7	60		

Esempio / Example:

Applicazione / Application:

Carrello automatico / Automatic carriage

P_1 : 140 W
 sf : 1.5
 n_2 : 150 min⁻¹

Motorizzazione scelta / Power unit selected:

ECM100/026, $i = 20$, $P_1 = 140$ W, $sf = 1.5$

ECMP

P_1 [W]	n_2 [min ⁻¹]	M_2 [Nm]	sf	i		Versione motore Motor version
250						
(3000 min ⁻¹)	50	35	2.3	60	ECMP180/063/050	120/240/24E
	40	42	1.8	75		
	33	48	2.1	90		
	25	58	1.5	120		
	20	69	1.2	150		
	17	77	1.0	180		
	13	90	0.8	240		

Esempio / Example:

Applicazione / Application:

Carrello automatico / Automatic carriage

M_2 : 58 Nm
 sf : 1.5
 n_2 : 25 min⁻¹

Motorizzazione scelta / Power unit selected:

ECMP180/063/050, $i = 120$, $P_1 = 250$ W, $sf = 1.5$

Installazione e verifiche

In fase di installazione del motoriduttore è opportuno verificare che:

- i dati riportati in targhetta corrispondano al prodotto che è stato ordinato;
- le superfici di accoppiamento e gli alberi siano accuratamente puliti e privi di ammaccature;
- le superfici su cui verrà installato il riduttore siano perfettamente piane e sufficientemente rigide;
- l'albero macchina e quello del riduttore siano correttamente allineati;
- siano stati installati sistemi di limitazione della coppia se si prevedono urti o blocchi della macchina durante il funzionamento;
- siano state predisposte le necessarie protezioni antinfortunistiche agli organi rotanti;
- siano state create delle opportune coperture a protezione dagli agenti atmosferici se l'installazione è effettuata all'aperto ed è soggetta alle intemperie;
- l'ambiente di lavoro non sia corrosivo (a meno che tale specifica non sia stata dichiarata in fase di ordine al fine di predisporre il riduttore per questo utilizzo);
- gli eventuali pignoni o pulegge montati sull'albero uscita o entrata del riduttore, siano calettati correttamente in modo tale da non generare carichi radiali e/o assiali superiori a quelli ammissibili;
- su tutti gli accoppiamenti sia stato applicato un adeguato protettivo antiossidante per prevenire eventuali ossidazioni da contatto;
- tutte le viti di fissaggio siano state serrate correttamente.

Installation and inspection

While installing the gearmotor always make sure that:

- *the specifications stamped on the rating plate match those indicated for the unit actually ordered;*
- *the mating surfaces and the shafts are thoroughly clean and free of dents;*
- *the surfaces where the gearbox are to be mounted on are flat and strong enough;*
- *the machine drive shaft and the gearbox shaft are perfectly aligned;*
- *the required torque limiters have been installed if the machine is likely to produce shocks or blockages during operation;*
- *the rotary parts have been provided with the required safety guards;*
- *adequate weatherproof covering has been provided if the machine is to be installed outdoor;*
- *the working environment is not exposed to corrosive agents (unless this has been indicated while placing the order so that the gearbox assembly can be adequately set up);*
- *the pinions or pulleys on the gearbox input/output shafts are properly fitted in order not to produce radial and/or axial loads that exceed the maximum allowable limits;*
- *all the couplings have been treated with adequate rust preventative in order to avoid oxidation provoked by contact;*
- *all the mounting screws have been securely tightened.*

Applicazioni critiche

In tutti questi casi consultare il Servizio Tecnico

- utilizzo come organo di sollevamento;
- utilizzo in posizioni non previste a catalogo;
- utilizzo in ambiente con pressione diversa da quella atmosferica;
- utilizzo in ambiente con temperature <0°C o >+40°C
- utilizzo in ambienti esterni

Critical applications

In these cases please contact the Technical Service

- *used as a hoist;*
- *used in mounting positions not shown in the catalogue;*
- *used in environment pressure other than atmospheric pressure;*
- *used in places with temperature <0°C or >+40°C*
- *when used outdoors*

MINI 
TECNO
small but strong

CL

Motoriduttori a vite senza fine
Wormgearmotors



MINI 
TECNO brand of
TRANSTECNO[®]



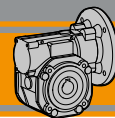

Indice	Index	Pag. Page
Caratteristiche tecniche	<i>Technical features</i>	II2
Designazione	<i>Classification</i>	II2
Sensi di rotazione	<i>Direction of rotation</i>	II3
Simbologia	<i>Symbols</i>	II3
Lubrificazione	<i>Lubrication</i>	II3
Carichi radiali	<i>Radial loads</i>	II4
Dati di dentatura	<i>Toothing data</i>	II4
Rendimento	<i>Efficiency</i>	II4
Dati tecnici	<i>Technical data</i>	II5
Motori applicabili	<i>IEC Motor adapters</i>	II5
Dimensioni	<i>Dimensions</i>	II6
Accessori	<i>Accessories</i>	II12
Opzioni	<i>Options</i>	II12

Questa sezione annulla e sostituisce ogni precedente edizione o revisione. Qualora questa sezione non Vi sia giunta in distribuzione controllata, l'aggiornamento dei dati ivi contenuto non è assicurato. **In tal caso la versione più aggiornata è disponibile sul nostro sito internet www.transtecno.com**

This section replaces any previous edition and revision. If you obtained this catalogue other than through controlled distribution channels, the most up to date content is not guaranteed. In this case the latest version is available on our web site www.transtecno.com

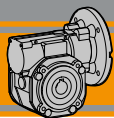

CL

Motoriduttori a vite senza fine Wormgearmotors



Caratteristiche tecniche

Technical features

L'elevata modularità contraddistingue i motoriduttori a vite senza fine della serie CL: i diversi kit entrata ed uscita li rendono estremamente versatili.

The high degree of modularity is a design feature of CL wormgearmotors range thanks to a wide selection of input and output kits. Main features of CL range are:

Le caratteristiche principali della serie CL sono:

- Carcassa in alluminio
- Lubrificazione permanente con olio sintetico
- Die-cast aluminium housing
- Permanent synthetic oil long life lubrication

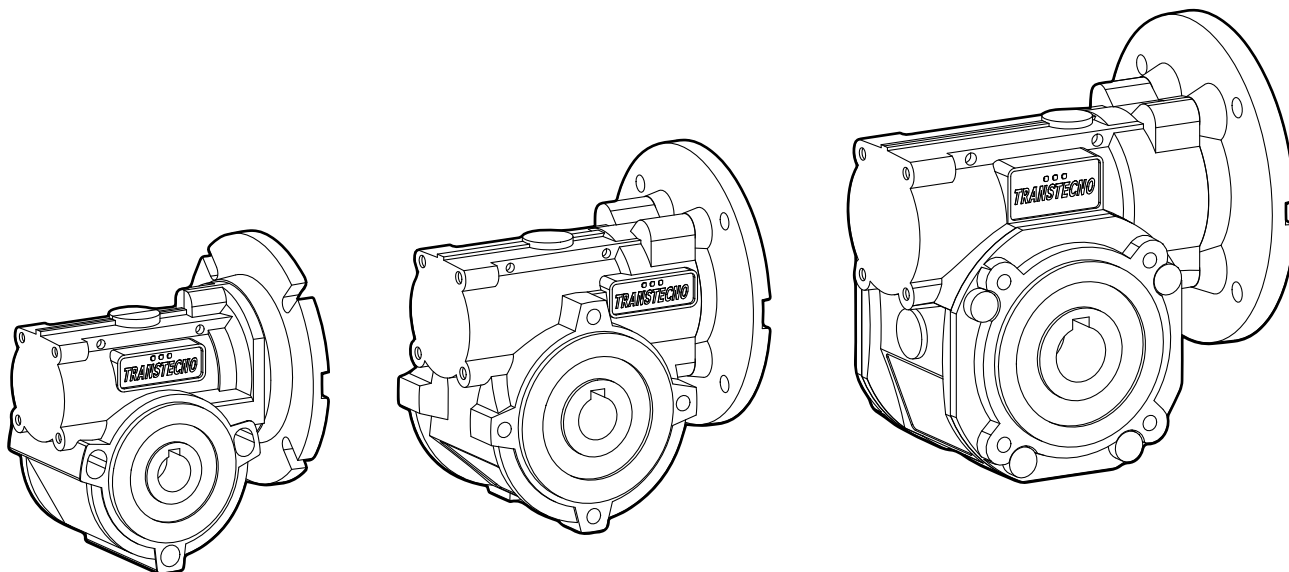

Designazione

Classification

RIDUTTORI A VITE SENZA FINE / WORMGEARBOXES

RIDUTTORE / GEARBOX

CL	030	U	10	63	B14	SZDX	BRSX	90	VS
Tipo Type	Grandezza Size	Versione riduttore Gearbox Version	Rapporto Ratio	IEC 	Forma costruttiva Version	Albero di uscita Output shaft	Braccio di reazione Torque arm	Angolo Angle	Opzioni Options
CL 	026 026 (D11) 026 (D14) 030 040	U F...	Vedere tabella See tables	56.. — 71..	B5 B14	SZDX SZSX DZ	BRDX BRSX 	0° 90° 180° 270°	VS
CLIS 									

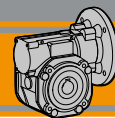

Designazione

Classification

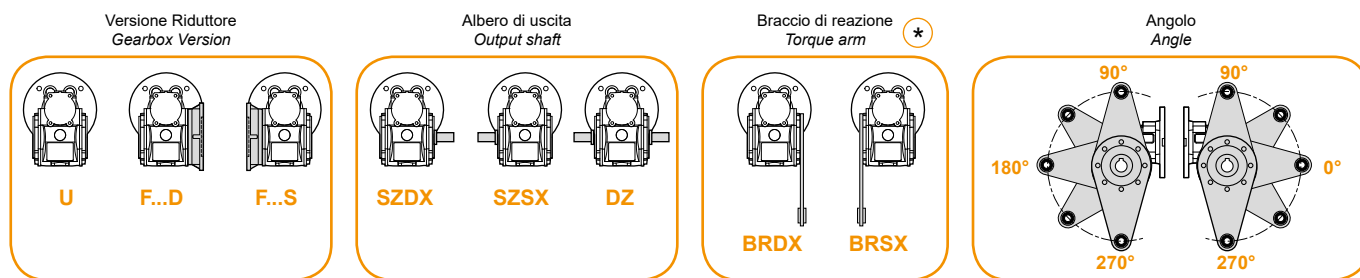

* NOTA: il braccio di reazione viene fornito smontato.
NOTE: the torque arm will be supplied not assembled.

Sensi di rotazione

Direction of rotation

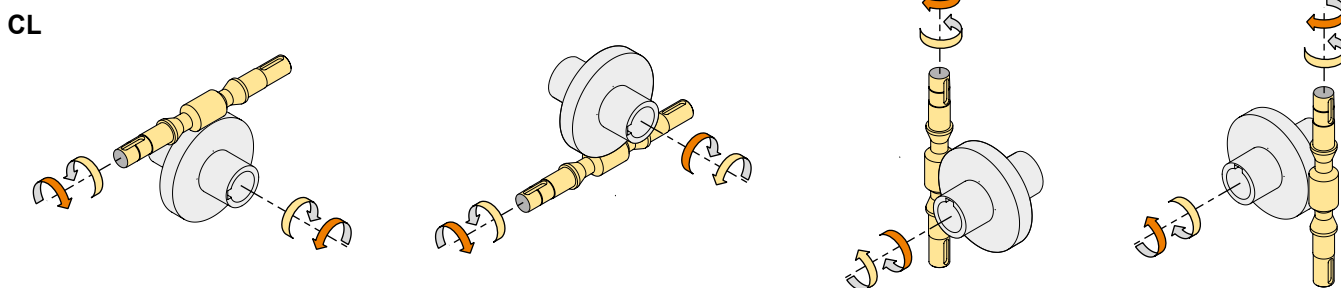

Simbologia

Symbols

n_1 [min ⁻¹]	Velocità in ingresso / Input speed	sf	Fattore di servizio / Service factor
n_2 [min ⁻¹]	Velocità in uscita / Output speed	Rd %	Rendimento dinamico / Dynamic efficiency
i	Rapporto di riduzione / Ratio	Rs %	Rendimento statico / Static efficiency
P_1 [kW]	Potenza in entrata / Nominal input power	R_2 [N]	Carico radiale ammissibile in uscita / Permitted output radial load
M_2 [Nm]	Coppia in uscita in funzione di P_1 / Output torque referred to P_1	A_2 [N]	Carico assiale ammissibile in uscita / Permitted output axial load
P_{n1} [kW]	Potenza nominale in entrata / Nominal input power	Z	Numero di principi della vite / Worm starts
M_{n2} [Nm]	Coppia nominale in uscita in funzione di P_{n1} / Nominal output torque referred to P_{n1}	β	Angolo d'elica / Helix angle

Lubrificazione

Lubrication

Tutti i motoriduttori sono forniti completi di lubrificante sintetico viscosità 320, pertanto possono essere installati in qualunque posizione di montaggio e non necessitano di manutenzione.

Permanent synthetic oil long-life lubrication (viscosity grade 320) makes it possible to use the gearmotors in all mounting positions; for this reason they can be installed in any assembly position and do not require maintenance.

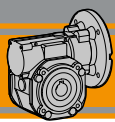

Carichi radiali

Radial loads

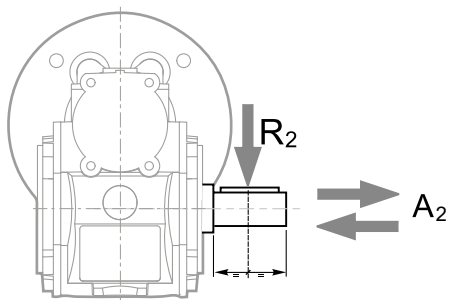

$$A_2 = R_2 \times 0.2$$

n ₂ [min ⁻¹]	R ₂ [N]		
	CL026	CL030	CL040
187	400	674	1264
140	490	743	1392
93	580	851	1596
70	610	936	1754
56	610	1008	1890
47	610	1069	2004
35	610	1179	2210
28	610	1270	2381
23	610	1356	2542
18	610	1471	2759
14	610	1600	3000

Quando il carico radiale risultante non è applicato sulla mezzeria dell'albero occorre calcolare quello effettivo con la seguente formula:

When the resulting radial load is not applied on the centre line of the shaft it is necessary to calculate the effective load with the following formula:

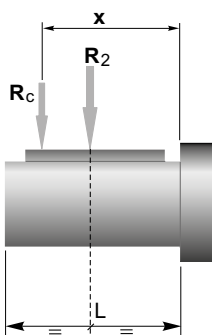

$$R_c = \frac{R_2 \cdot a}{(b+x)} \leq R_{2MAX}$$

$$R \leq R_c$$

a, b = valori riportati nella tabella
a, b = values given in the table

	CL		
	026	030	040
a	56	65	84
b	43	50	64
R _{2MAX}	610	1600	3000

Dati di dentatura

Toothing data

	Dati della coppia vite-corona Worm wheel data	Rapporto / Ratio											
		5	7.5	10	15	20	25	30	40	50	60	80	100
CL026	Z	6	4	3	2	2		1	1	1	1		
	β	34° 35'	24° 41'	19° 1'	12° 57'	10° 30'		6° 33'	5° 17'	4° 26'	3° 49'		
CL030	Z	6	4	3	2	2	2	1	1	1	1	1	1
	β	27° 4'	24° 28'	18° 50'	12° 49'	10° 23'	8° 43'	6° 29'	5° 14'	4° 23'	3° 46'	2° 57'	2° 25'
CL040	Z	6	4	3	2	2	2	1	1	1	1	1	1
	β	34° 19'	24° 28'	18° 50'	12° 49'	10° 23'	8° 43'	6° 29'	5° 14'	4° 23'	3° 46'	2° 57'	2° 25'

Rendimento

Efficiency

	n ₁ [min ⁻¹]	Rendimento Efficiency	Rapporto / Ratio											
			5	7.5	10	15	20	25	30	40	50	60	80	100
CL026	2800	Rd	89	87	85	83	80		73	68	64	60		
	1400		87	84	83	78	74		66	61	57	53		
	900		84	83	80	75	71		61	57	52	48		
CL030		Rs	72	71	68	61	56	46	41	36	34			
	2800	Rd	89	88	86	84	81	78	74	70	65	62	57	52
	1400		86	85	84	79	75	72	67	62	58	55	48	43
	900		84	83	81	75	71	68	62	58	53	49	43	39
CL040		Rs	72	67	63	55	50	43	39	35	31	27	23	21
	2800	Rd	90	89	87	84	83	80	77	73	69	66	60	56
	1400		88	86	84	81	78	74	70	65	60	58	52	46
	900		86	84	82	77	74	70	66	60	57	53	46	41
	Rs	74	71	67	60	55	51	45	40	36	32	28	24	

Rendimento teorico del riduttore dopo il rodaggio
Theoretical efficiency of the gearbox after the first running period

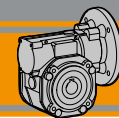

Dati tecnici

n_1 1400 min⁻¹

Technical data

	n_2 [min ⁻¹]	Mn_2 [Nm]	Pn_1 [kW]	i
CLIS026				
	280	13	0.44	5
	187	14	0.33	7,5
	140	14	0.25	10
	93	14	0.18	15
	70	14	0.14	20
	47	15	0.11	30
	35	14	0.08	40
	28	13	0.07	50
	23	12	0.06	60

CLIS030				
	280	18	0.61	5
	187	20	0.46	7.5
	140	21	0.37	10
	93	21	0.26	15
	70	19	0.19	20
	56	20	0.16	25
	47	22	0.16	30
	35	20	0.12	40
	28	19	0.10	50
	23	17	0.08	60
	18	15	0.06	80
	14	14	0.05	100

	n_2 [min ⁻¹]	Mn_2 [Nm]	Pn_1 [kW]	i
CLIS040				
	280	41	1.37	5
	187	44	1.00	7.5
	140	45	0.79	10
	93	45	0.54	15
	70	40	0.38	20
	56	38	0.30	25
	47	48	0.34	30
	35	42	0.24	40
	28	39	0.19	50
	23	36	0.15	60
	18	33	0.12	80
	14	31	0.10	100

Nota:
 Pn_1 è la potenza meccanica.
 La potenza applicabile è ridotta del fattore termico.
 Per maggiori dettagli consultare il nostro Servizio Tecnico.

Note:
 Pn_1 is an input mechanical power which must be reduced by the heating factor in order to get the relevant one. For more details please contact our Technical Service.

Motori applicabili

IEC Motor adapters

	IEC	N	M	P	D	i																		
						5	7.5	10	15	20	25	30	40	50	60	80	100							
CL026	56B14	50	65	80	9																			
CL030	63B5	95	115	140	11																			
	63B14	60	75	90																				
	56B5	80	100	120	9																			
	56B14	50	65	80																				
CL040	71B5	110	130	160	14																			
	71B14	70	85	105																				
	63B5	95	115	140	11	B	B	B	B	B	B	B	B											
	63B14	60	75	90																				
	56B5	80	100	120	9	BS	BS	BS	BS	BS	BS	BS	BS	BS	B	B	B	B						
	56B14	50	65	80																				

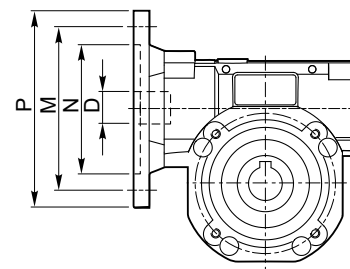

N.B.
 Le aree evidenziate in grigio indicano l'applicabilità della corrispondente grandezza motore.
 N.B. Grey areas indicate motor inputs available on each size of unit.

B/BS = Boccola di riduzione in acciaio

B/BS = Metal shaft sleeve

Nota: flange Nema disponibili a richiesta
 Note: Nema flange available on demand

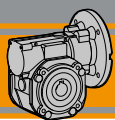

Dimensioni

Dimensions

CL 026 U

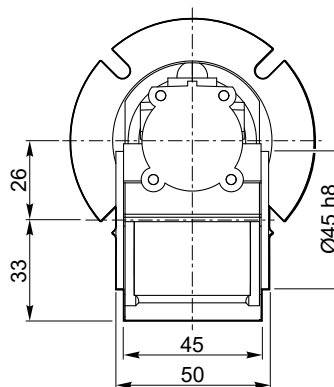
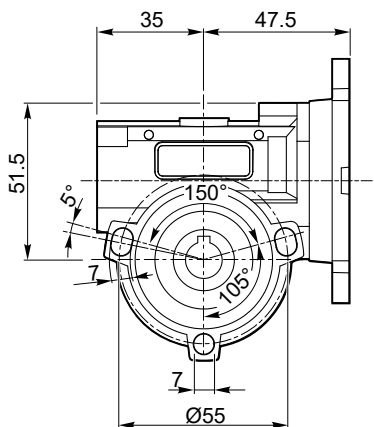

Kg
0.7

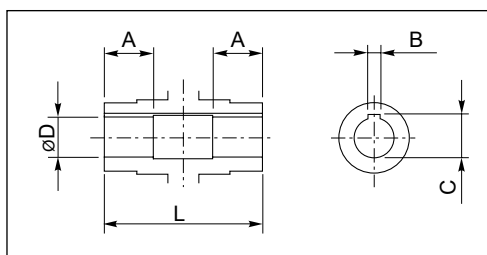

Albero lento cavo / Hollow output shaft

Grandezza Size	Ø D H8	L	A	B	C
CL 026 (D14)	14	50	15	5	16.2
CL 026	12	50	15	4	13.8
CL 026 (D11)	11	50	15	4	12.8

CLIS 026 ..

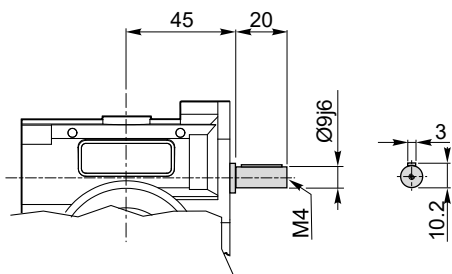

CL 026 F

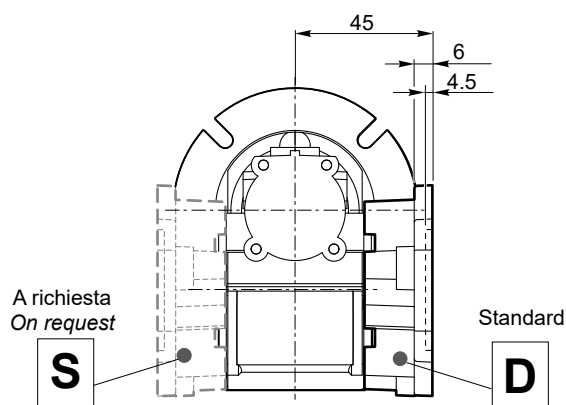
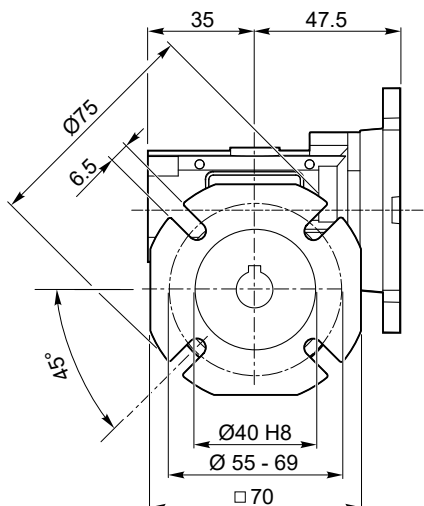

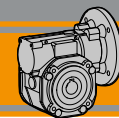

Dimensioni

Dimensions

CL 026 F28

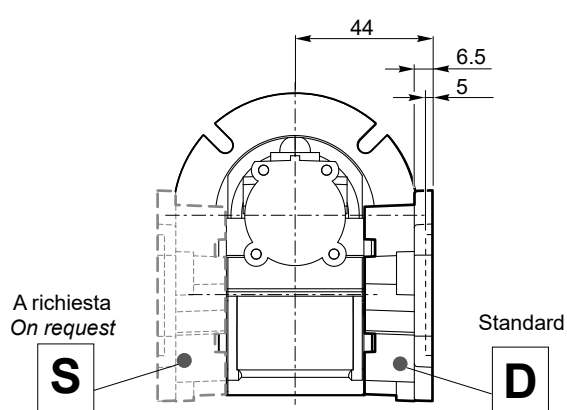
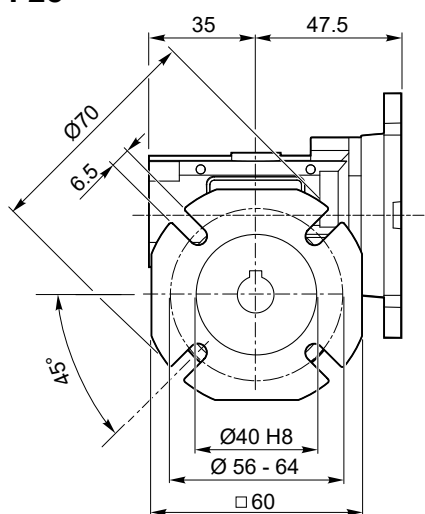

CL 026 F30

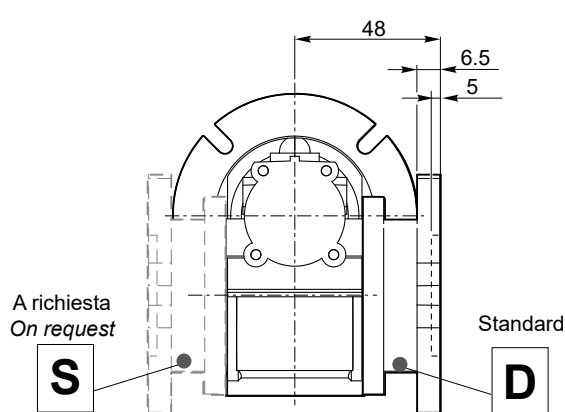
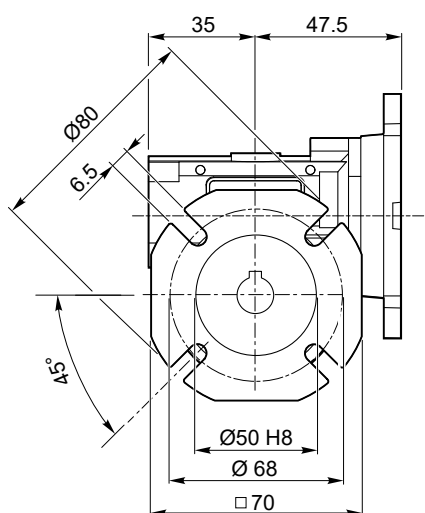

CL 026 F30C

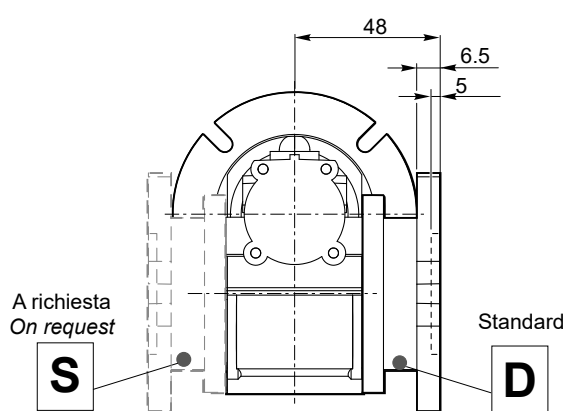
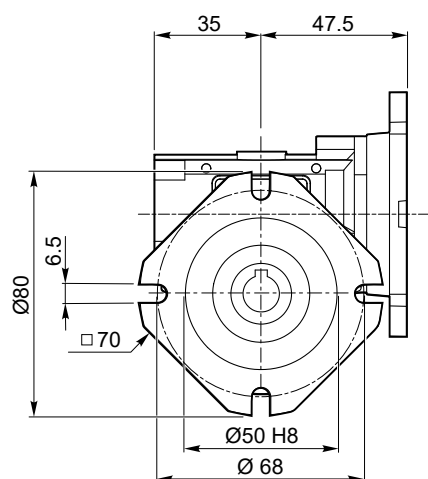

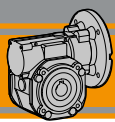

Dimensioni

Dimensions

CL 026 F30S

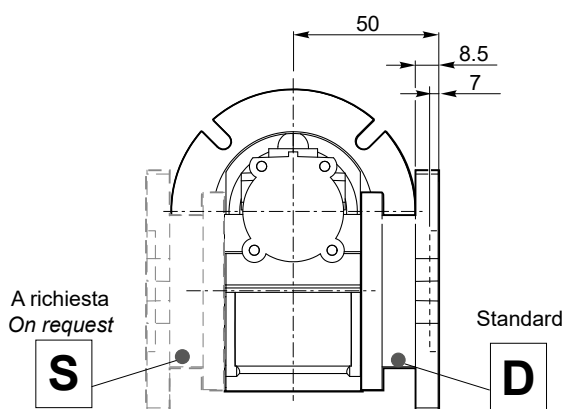
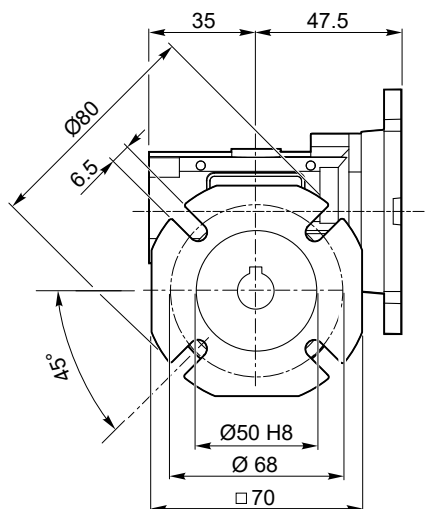

Nota: Esecuzione con flangia uscita F30 e spessore 2mm
Note: Made with flange F30 and spacer with 2mm thickness

CL 026 F30SC

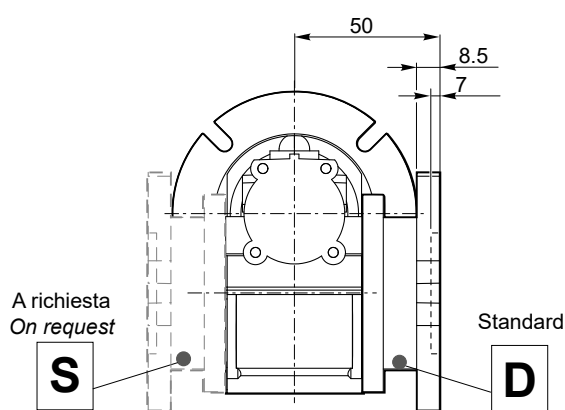
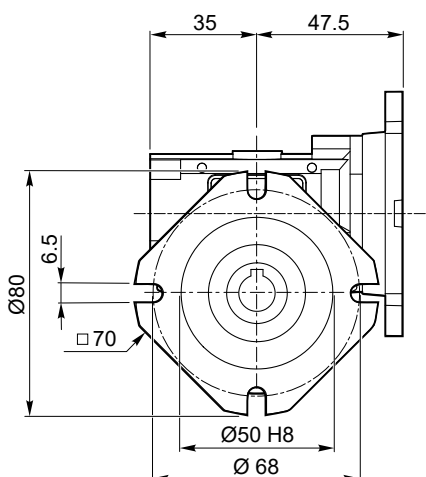

Nota: Esecuzione con flangia uscita F30C e spessore 2mm
Note: MAde with flange F30C and spacer with 2mm thickness

CL 026 F100

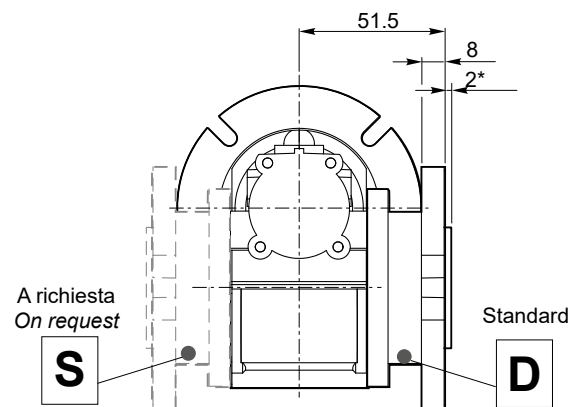
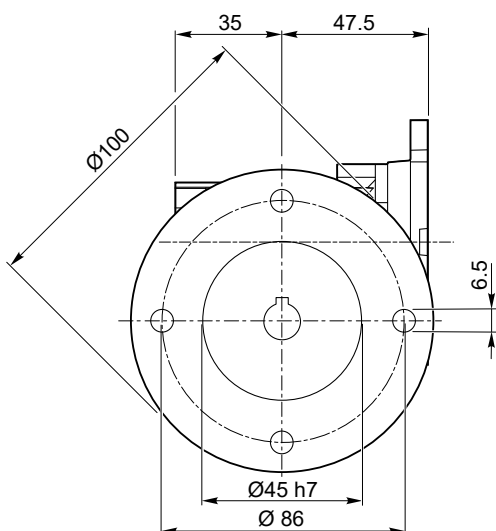

(*): Centraggio maschio
(*): Male centering diameter

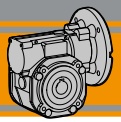

Dimensioni

Dimensions

CL 030 U

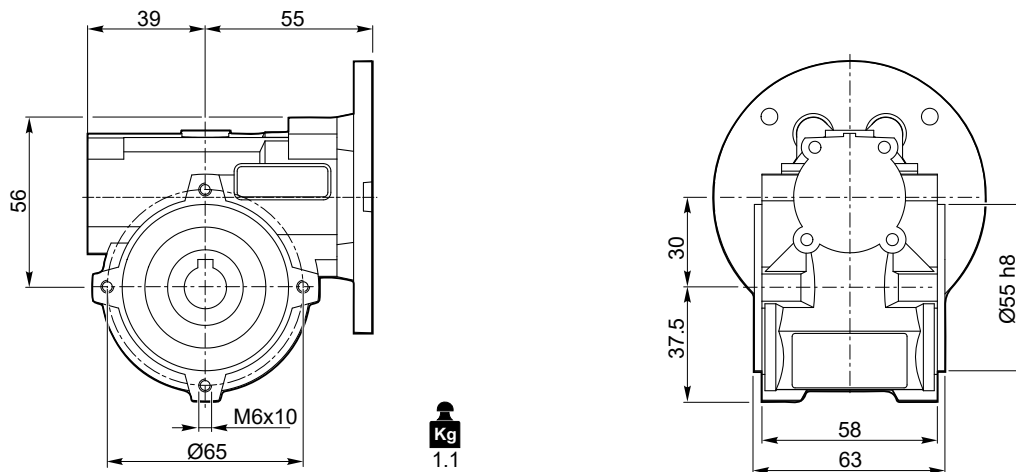

Kg
1.1

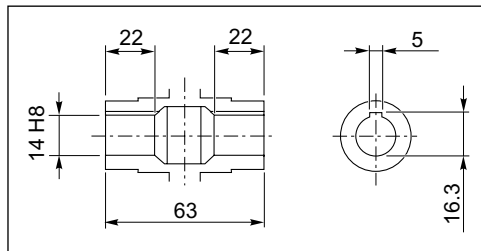

Albero lento cavo / Hollow output shaft

CLIS 030 ..

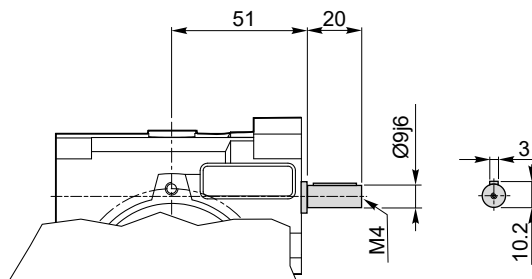

CL 030 F

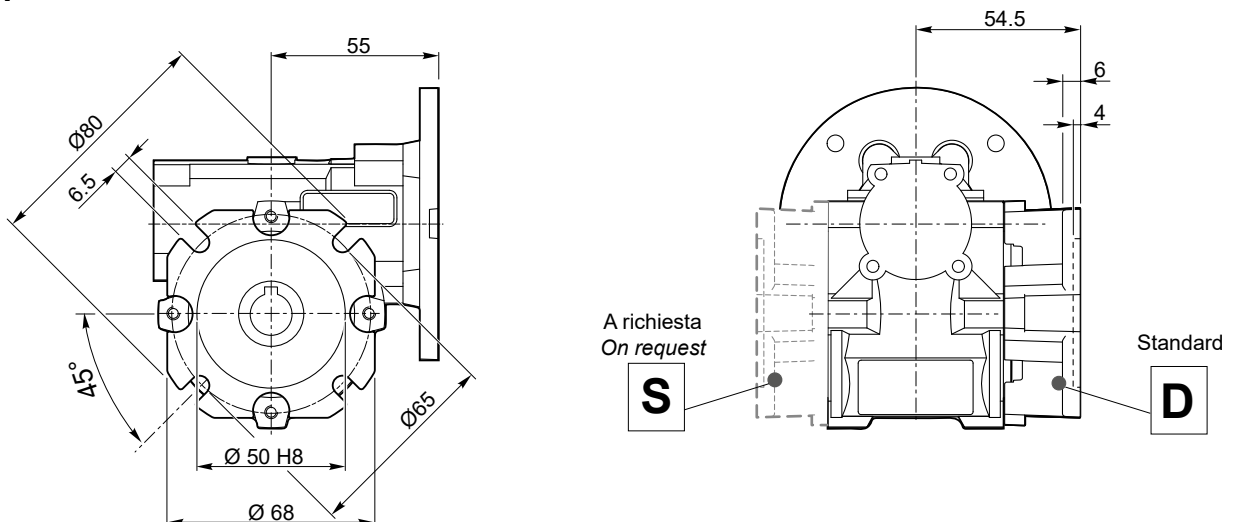

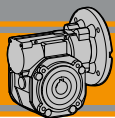
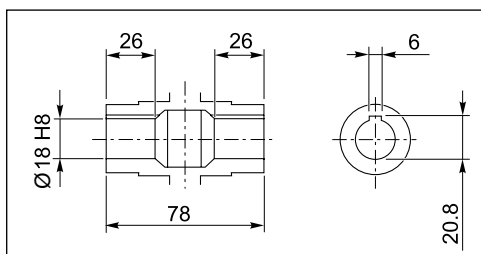
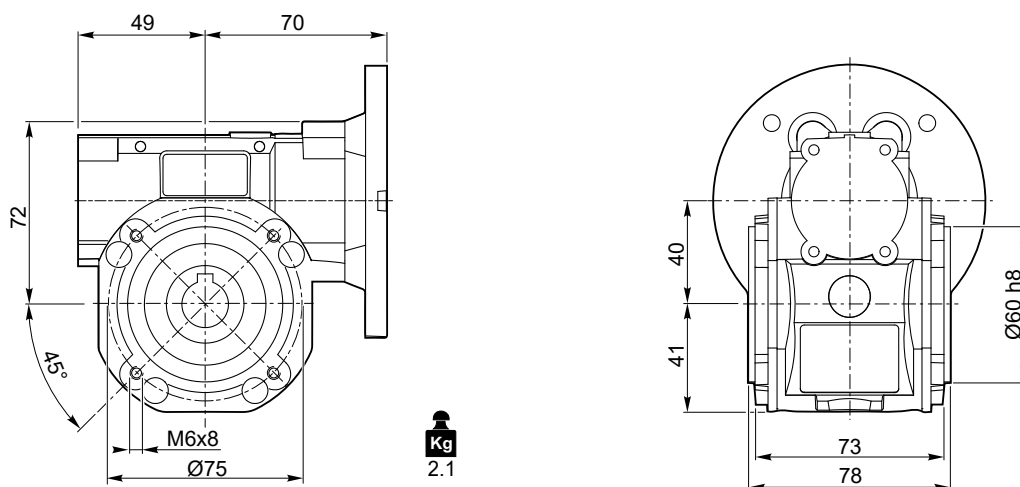
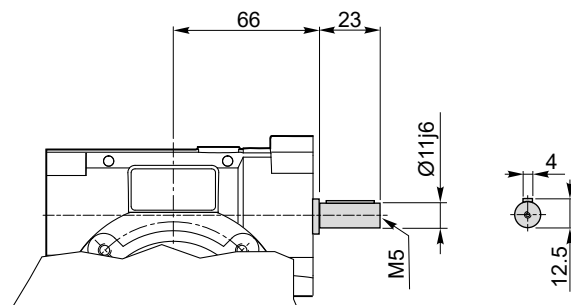
**CL****Motoriduttori a vite senza fine**
Wormgearmotors**MINI**
TECNO**Dimensioni****Dimensions****CL 040 U***Albero lento cavo / Hollow output shaft***CLIS 040 ..**

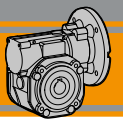

Dimensioni

Dimensions

CL 040 F

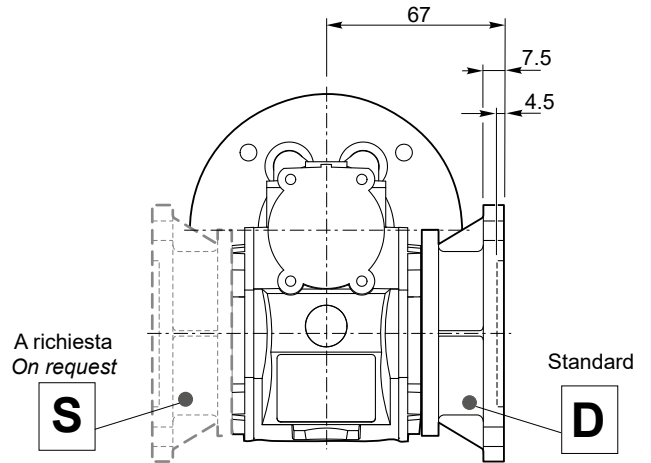
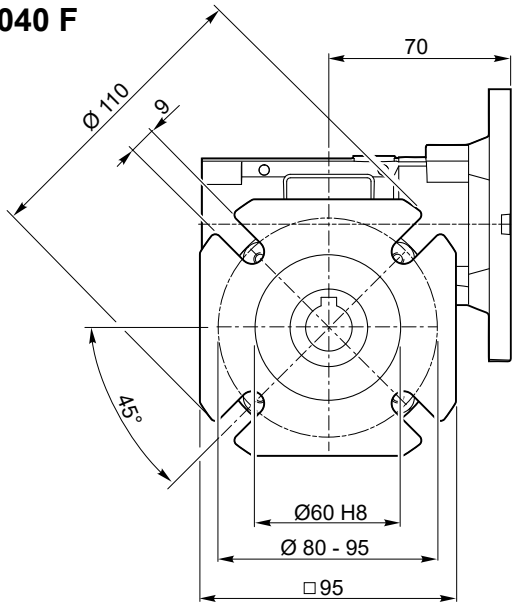

CL 040 FB

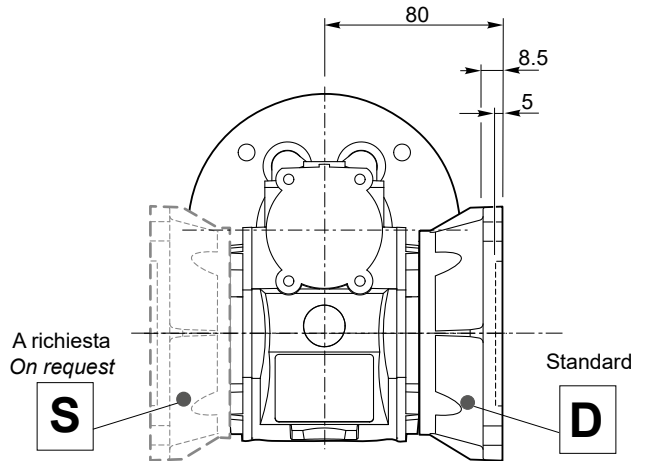
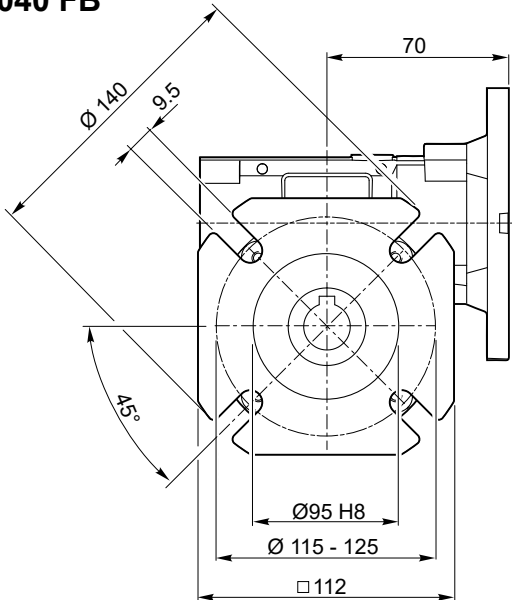

CL 040 FL

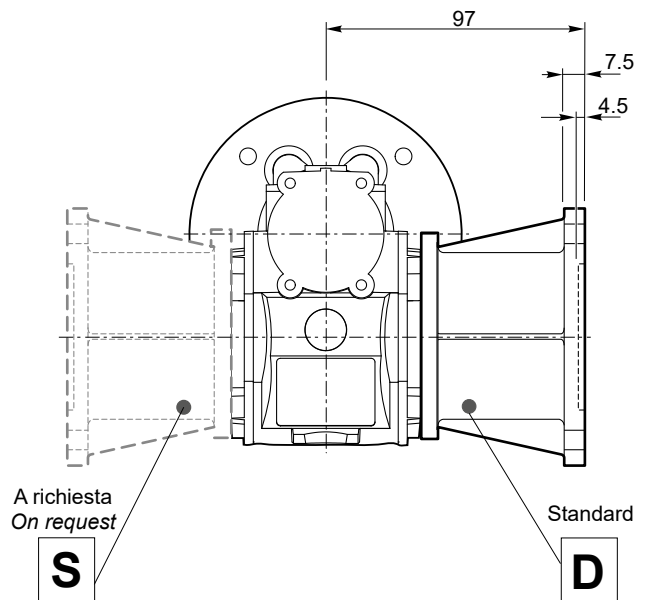
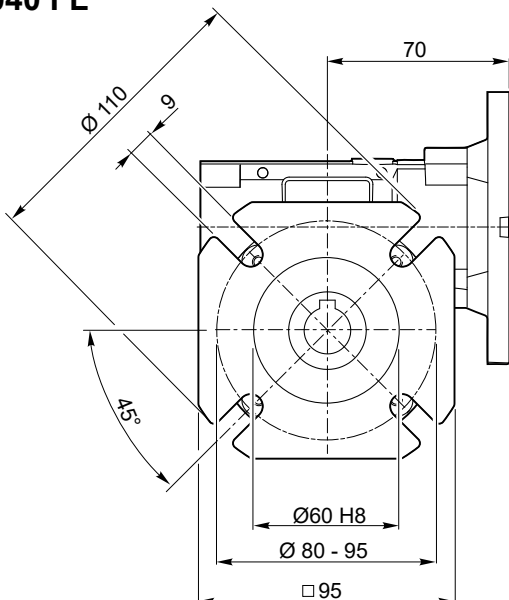

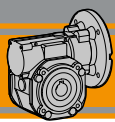

CL

Motoriduttori a vite senza fine
Wormgearmotors



Accessori

Accessories

Albero lento semplice e doppio

Single and double output shaft

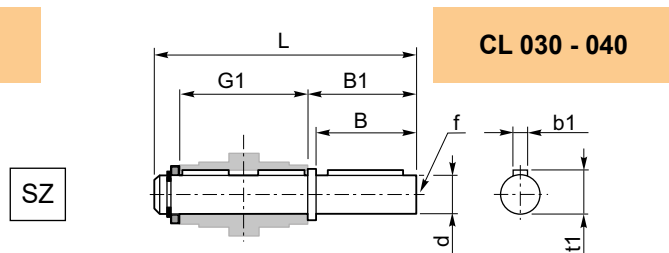
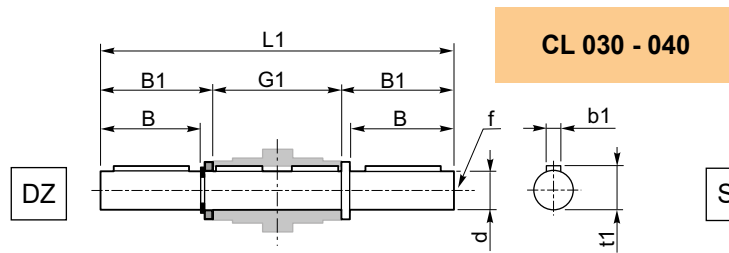

CL	d _{h7}	B	B1	G1	L	L1	f	b1	t1
030	14	30	32.5	63	102	128	M6	5	16
040	18	40	43	78	128	164	M6	6	20.5

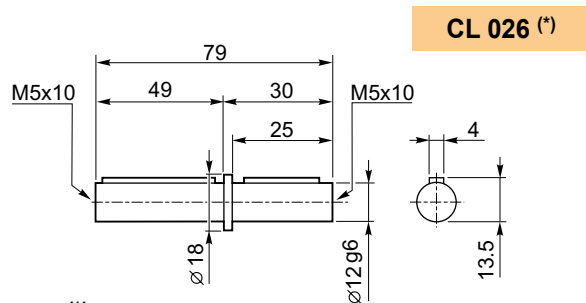

(*)
Nota: disponibile solo per cavo uscita Ø12
Note: available for output hollow shaft Ø12 only

Braccio di reazione

Torque arm

CL	K1	G	KG	KH	R
030	85	14	23	8	15
040	100	14	31	10	18

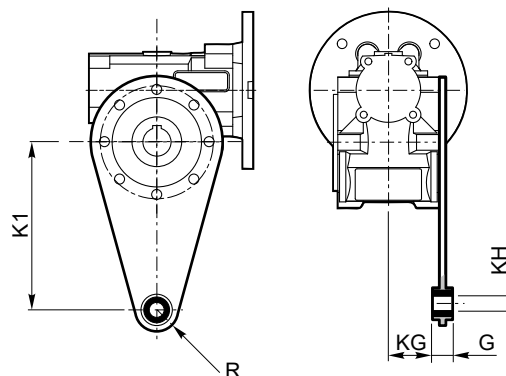

SC - Safety Cover

CL	M
030	47
040	54.5

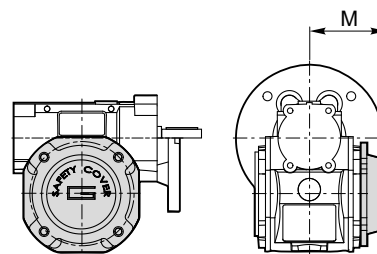

Opzioni

Options

VS - Vite sporgente / Extended input shaft

CL	A	B	D _{1j6}	E	F	G
030	45	20	9	M4	3	10.2
040	53	23	11	M5	4	12.5

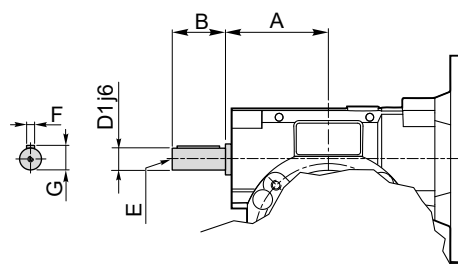

Costruito su richiesta
Built on request

MINI  **TECNO**
small but strong





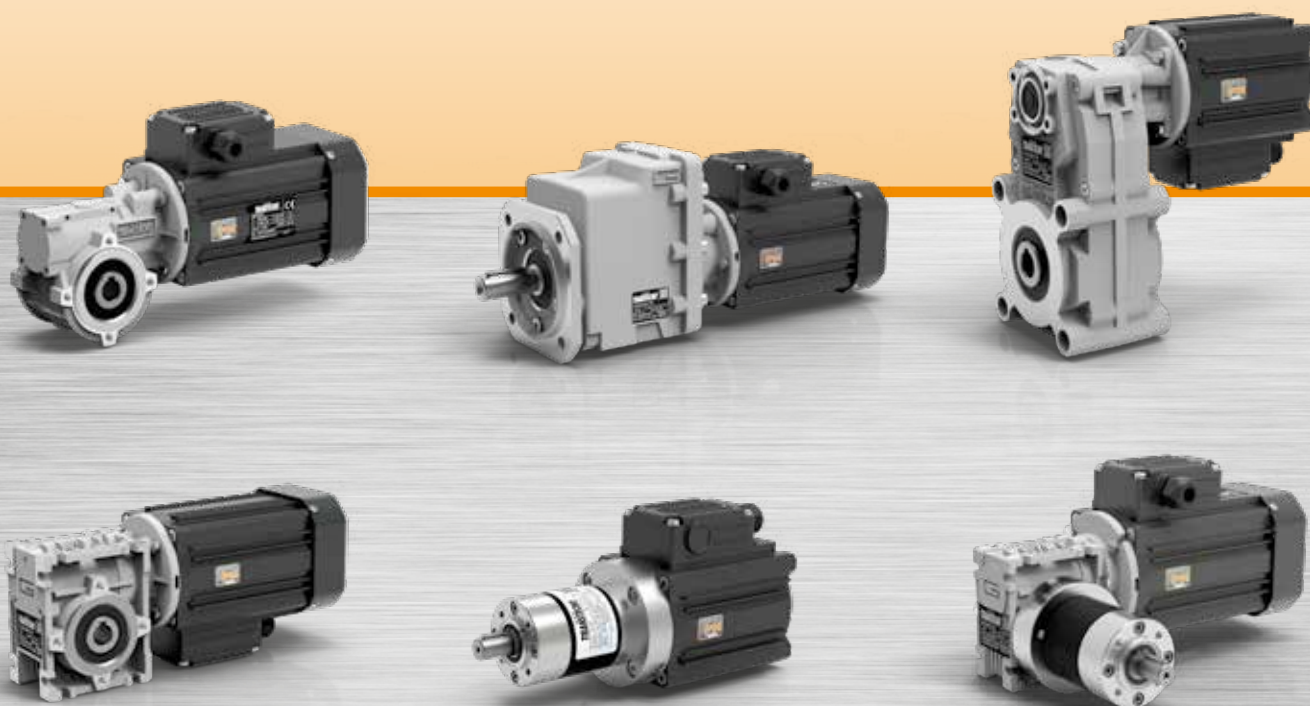







Motoriduttori CA
AC gearmotors

AC



MINI  **TECNO** brand of
TRANSTECNO



	Indice	Index	Pag. Page
	A-A Motori elettrici CA SM	AC Electric motors SM	A-A1
 	A-B Motoriduttori CA ad ingranaggi cilindrici CMG	AC Helical in-line gearmotors CMG	A-B1
 	A-C Motoriduttori CA ad assi ortogonali CMB	AC Helical bevel gearmotors CMB	A-C1
 	A-D Motoriduttori CA pendolari KFT105 - FT	AC Helical parallel gearmotors KFT105 - FT	A-D1
	A-E Motoriduttori CA a vite senza fine CM/CMP	AC Wormgearmotors CM/CMP	A-E1
	A-F Motoriduttori CA combinati a vite senza fine CMM	AC Doble reduction wormgearmotors CMM	A-F1
 	A-G Motoriduttori CA epicicloidali P	AC Planetary gearmotors P	A-G1
	A-H Motoriduttori CA combinati WMP	AC Doble reduction gearmotors WMP	A-H1

Questo catalogo annulla e sostituisce ogni precedente edizione o revisione.
Ci riserviamo inoltre il diritto di apportare modifiche senza preavviso.
La versione più aggiornata è disponibile sul sito
www.transtecno.com

*This catalogue supersedes any previous edition and revision.
We reserve the right to implement modifications without notice.
The most updated version is available on our website
www.transtecno.com*

MINI 
TECNO
small but strong

SM



Motori elettrici asincroni CA
AC asynchronous electric motors



MINI 
TECNO brand of
TRANSTECNO



AC

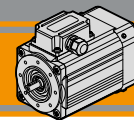

Indice	Index	Pag. Page
Caratteristiche tecniche	<i>Technical features</i>	AA2
Designazione	<i>Classification</i>	AA2
Simbologia e formule	<i>Symbols and formulas</i>	AA3
Dati tecnici	<i>Technical data</i>	AA3
Dimensioni motori trifase	<i>Three phase motors dimensions</i>	AA4
Dimensioni motori monofase	<i>Single phase motors dimensions</i>	AA4
Gradi di protezione IP	<i>IP protection rating</i>	AA8
Normative di riferimento	<i>Reference standards</i>	AA8
Tipo di servizio IEC	<i>IEC duty cycles</i>	AA9
Grafico servizio più comuni	<i>Most common services diagram</i>	AA9
Classe di isolamento termico	<i>Insulation class</i>	AA10
Serie SM - Funzionamento in ambiente 60 Hz	<i>Series SM - 60 Hz line power supply</i>	AA10

Questa sezione annulla e sostituisce ogni precedente edizione o revisione. Qualora questa sezione non Vi sia giunta in distribuzione controllata, l'aggiornamento dei dati ivi contenuto non è assicurato. **In tal caso la versione più aggiornata è disponibile sul nostro sito internet www.transtecno.com**

This section replaces any previous edition and revision. If you obtained this catalogue other than through controlled distribution channels, the most up to date content is not guaranteed. In this case the latest version is available on our web site www.transtecno.com

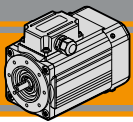

Caratteristiche tecniche

Technical characteristics

I motori delle serie SMT ed SMM hanno le seguenti caratteristiche principali:

SMT and SMM motor range has the following main features:

- Costruzione compatta
- Motorizzazioni in corrente alternata monofase e trifase
- Carcassa estrusa in alluminio anodizzato nero
- Motore elettrico AC con grado di protezione IP66
- Rumorosità e vibrazioni contenute
- Isolamento termico di classe F
- Flangia motore IEC B14
- Temperatura ambiente: -20°C / + 40°C
- Disponibili sia nella versione ventilata TEFC (servizio S1) che non ventilata TENV (servizio S3)
- Protezioni termiche per le taglie 56 e 63
- SMT56 e SMT63 adatti al funzionamento con alimentazione da inverter

- Compact design
- AC single phase and three phase motors available
- Extruded aluminum housing black anodized
- AC electric motor in IP66 protection Standard
- Low noise and vibrations
- Class F insulation Standard
- Motor flange IEC B14
- Ambient temperature: -20°C / +40°C
- Fan cooled TEFC (duty S1) and not ventilated TENV (duty S3) versions available
- Thermal protection for motor sizes 56 and 63
- SMT56 and SMT63 are suitable for running with inverter

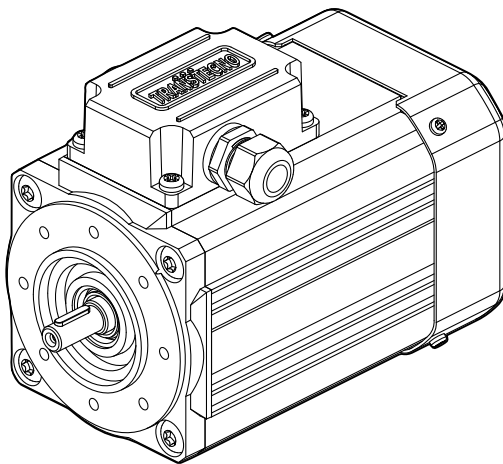

SM .. TEFC

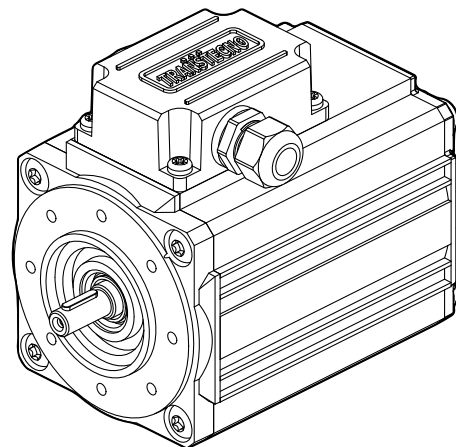

SM .. TENV

Designazione

Classification

SMT	63	2	4	B14	230-400 V	50 Hz	TEFC
Tipo Type	Grandezza Size	Indicativo potenza Power coefficient	Poli Poles	Forma costruttiva Version	Tensione Voltage	Frequenza Frequency	Ventilazione Fan cooling
SMT trifase three phase	vedi tabelle see tables	1-2-3-4-5	4	B14	230-400 V	50Hz 60Hz	TEFC TENV
SMM	63	2	4	B14	230 V	50 Hz	TEFC
Tipo Type	Grandezza Size	Indicativo potenza Power coefficient	Poli Poles	Forma costruttiva Version	Tensione Voltage	Frequenza Frequency	Ventilazione Fan cooling
SMM monofase single phase	vedi tabelle see tables	1-2-3-4	4	B14	230 V	50Hz	TEFC TENV

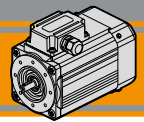
Simbologia e formule
Symbols and formulas

P_n	[kW]	Potenza nominale	Rated power
I_n	[A]	Corrente nominale (a 400V)	Rated current (at 400V)
M_n	[Nm]	Coppia nominale	Rated torque
n_n	[rpm]	Velocità nominale	Rated speed
M_s / M_n		Rapporto coppia spunto / coppia nominale	Ratio start torque / rated torque
M_k / M_n		Rapporto coppia massima / coppia nominale	Ratio max torque / rated torque
I_s / I_n		Rapporto corrente di spunto / corrente nominale	Ratio start current / rated current
$\cos\varphi$		Fattore di potenza al carico nominale	Power factor at rated torque load
η		Rendimento al carico nominale	Efficiency at rated torque load
Potenza Power	[HP]	Potenza [kW] x 1.34 circa	Power [kW] x 1.34 (about)
Potenza resa P_n P_n output power	[kW]	Potenza assorbita x η	Absorbed power x η
Pot. assorbita Absorbed power	[kW]	$\frac{\sqrt{x} \cdot I \cdot PF}{1000}$ (monofase)	$\frac{\sqrt{x} \cdot I \cdot PF}{1000}$ (singlephase)
		$\frac{\sqrt{x} \cdot I \cdot \sqrt{3} \cdot PF}{1000}$ (trifase)	$\frac{\sqrt{x} \cdot I \cdot \sqrt{3} \cdot PF}{1000}$ (threephase)
I_n (230 V)		I_n (400 V) x $\sqrt{3}$	I_n (400 V) x $\sqrt{3}$

Dati tecnici
Technical data
Motori trifase serie SMT / SMT Series three phase motors

 poli / poles **4**

SMT	P_n [kW]	M_n [Nm]	n_n [min ⁻¹]	I_n (400V) [A]	η %	$\cos\varphi$	M_s/M_n	I_s/I_n	M_k/M_n	TEFC Servizio Duty	TENV Servizio Duty	Kg
5014	0.04	0.30	1290	0.25	34.0	0.68	1.65	1.75	1.70	S1 100%	S3 30%	2.3
5024	0.06	0.44	1300	0.35	35.7	0.69	1.55	1.80	1.60			2.7
5034	0.09	0.65	1315	0.54	38.0	0.64	1.8	2.00	1.85			3.5
5044	0.12	0.87	1315	0.64	43.0	0.63	1.80	2.00	1.80			4.2
5624	0.09	0.63	1360	0.43	46.0	0.66	2.20	2.30	2.20			2.8
5634	0.12	0.89	1300	0.45	52.0	0.74	1.90	2.40	1.90			3.2
5644	0.18	1.26	1360	0.69	59.0	0.65	2.50	3.00	2.60			4.4
5654	0.25	1.8	1330	0.93	59.0	0.66	2.50	2.60	2.50			5.1
6324	0.18	1.26	1360	0.69	57.0	0.66	2.50	2.90	2.50			4.3
6334	0.25	1.74	1375	0.94	62.0	0.64	2.80	3.00	2.80			5
6344	0.37	2.6	1360	1.24	65.3	0.66	2.70	3.00	2.70			6.2

Motori monofase serie SMM / SMM Single phase motors

 poli / poles **4**

SMM	P_n [kW]	M_n [Nm]	n_n [min ⁻¹]	I_n (230V) [A]	η %	$\cos\varphi$	M_s/M_n	I_s/I_n	M_k/M_n	Cond/ cap [uF]	TEFC Servizio Duty	TENV Servizio Duty	Kg
5014	0.04	0.27	1390	0.60	33.4	0.88	0.74	1.6	1.55	8	S1 100%	S3 30%	2.7
5024	0.06	0.42	1380	0.89	34.3	0.85	0.76	1.7	1.50	12			3.5
5034	0.09	0.63	1375	1.10	40.0	0.89	0.80	1.7	1.45	16			4.2
5624	0.09	0.64	1340	0.86	46.7	0.98	0.70	1.8	1.30	7			3.1
5634	0.12	0.85	1350	1.08	49.5	0.98	0.65	2.1	1.32	9			3.7
5644	0.18	1.30	1320	1.56	55.4	0.99	0.70	2.1	1.58	13			5
6324	0.18	1.28	1340	1.40	58.8	0.97	0.68	2.3	1.48	14			5.1
6334	0.25	1.8	1340	1.90	58.4	0.98	0.68	2.4	1.40	18			6.3

Nota:

Classe di rendimento Standard IE1

Note:

Standard efficiency IE1

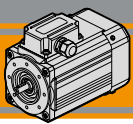

Dimensioni motori trifase

Three phase motors dimensions

SMT50.. - B14 - TEFC

SMT50.. - B14 - TENV S3 ^{servizio} _{duty} 30%

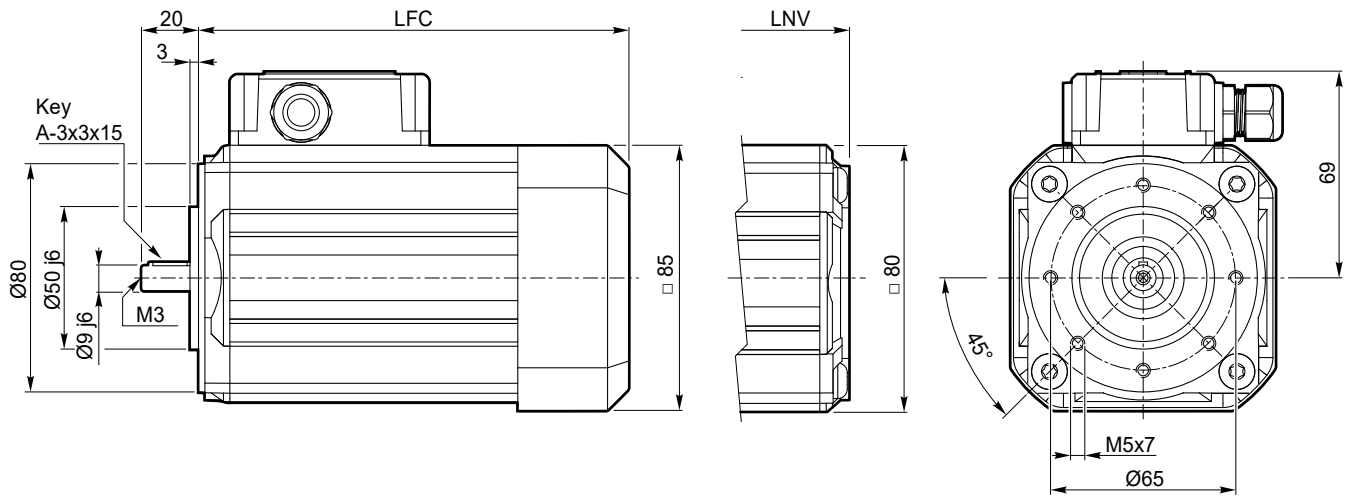

SMT	LFC	LNV
5014	135.5	108.5
5024	150.5	123.5
5034	175.5	148.5
5044	200.5	173.5

SMT56.. - B14 - TEFC

SMT56.. - B14 - TENV S3 ^{servizio} _{duty} 30%

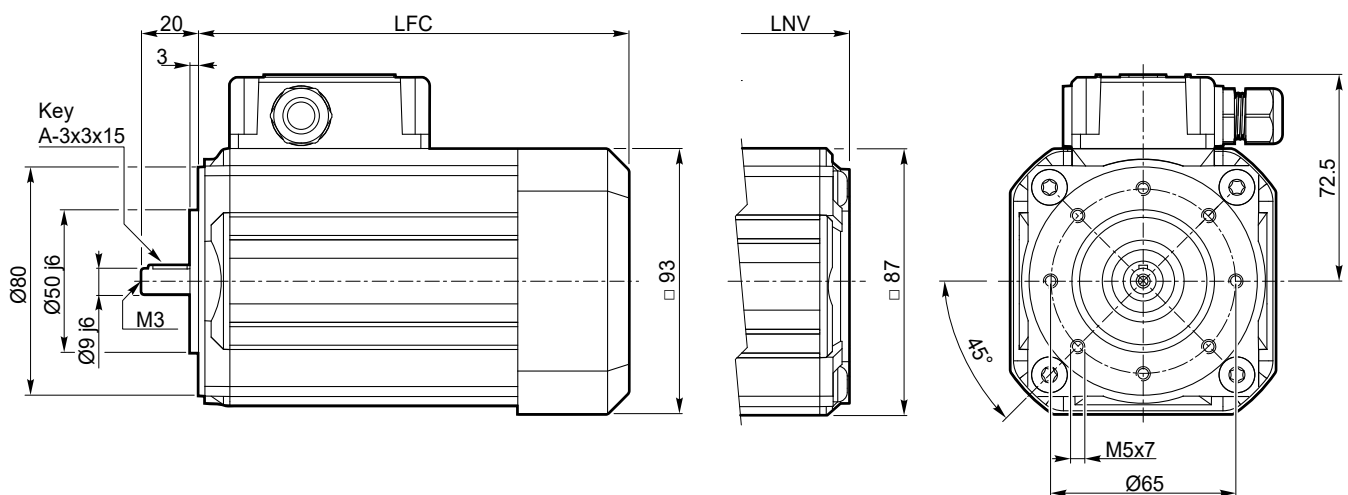

SMT	LFC	LNV
5624	141	117
5634	151	127
5644	186	162
5654	206	182

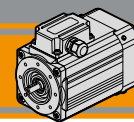

Dimensioni motori trifase

Three phase motors dimensions

SMT63.. - B14 - TEFC

SMT63.. - B14 - TENV S3 ^{servizio} _{duty} 30%

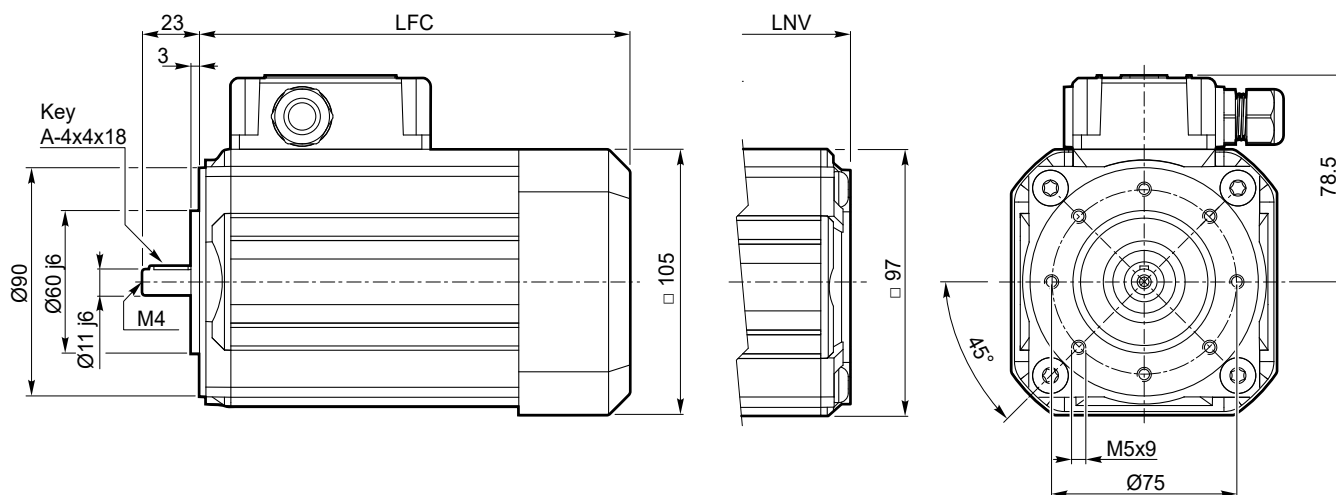

SMT	LFC	LNV
6324	165.5	138.5
6334	180.5	153.5
6344	205.5	178.5

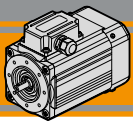

Dimensioni motori monofase

Single phase motors dimensions

SMM50.. - B14 - TEFC

SMM50.. - B14 - TENV S3 servizio *duty* 30%

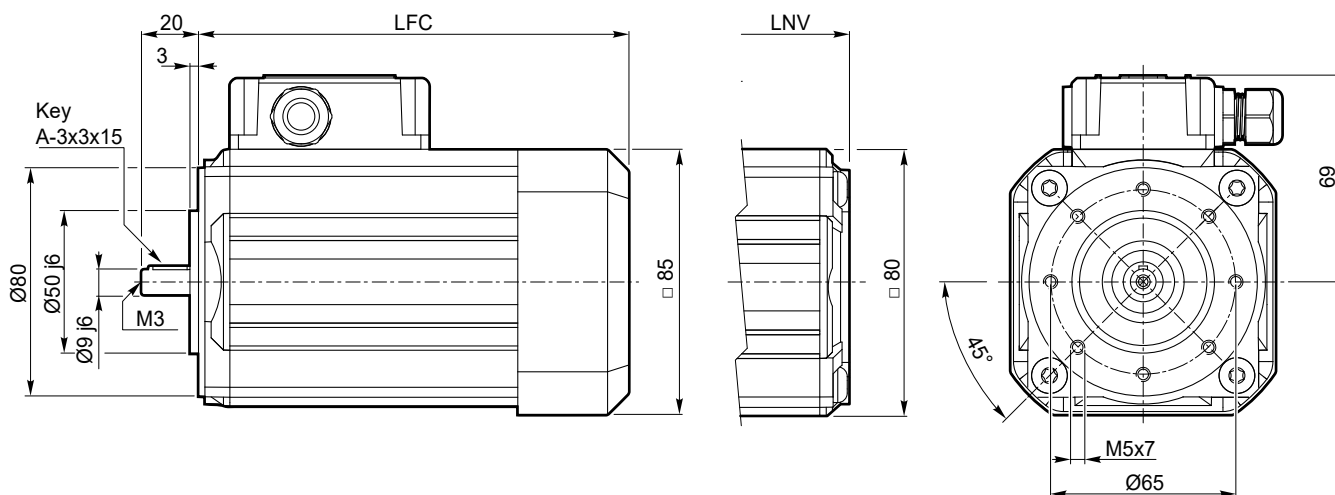

SMM	LFC	LNV
5014	150.5	123.5
5024	175.5	148.5
5034	200.5	173.5

Nota:
il condensatore sarà fornito a corredo

Note:
the capacitor will be supplied separately

SMM56.. - B14 - TEFC

SMM56.. - B14 - TENV S3 servizio *duty* 30%

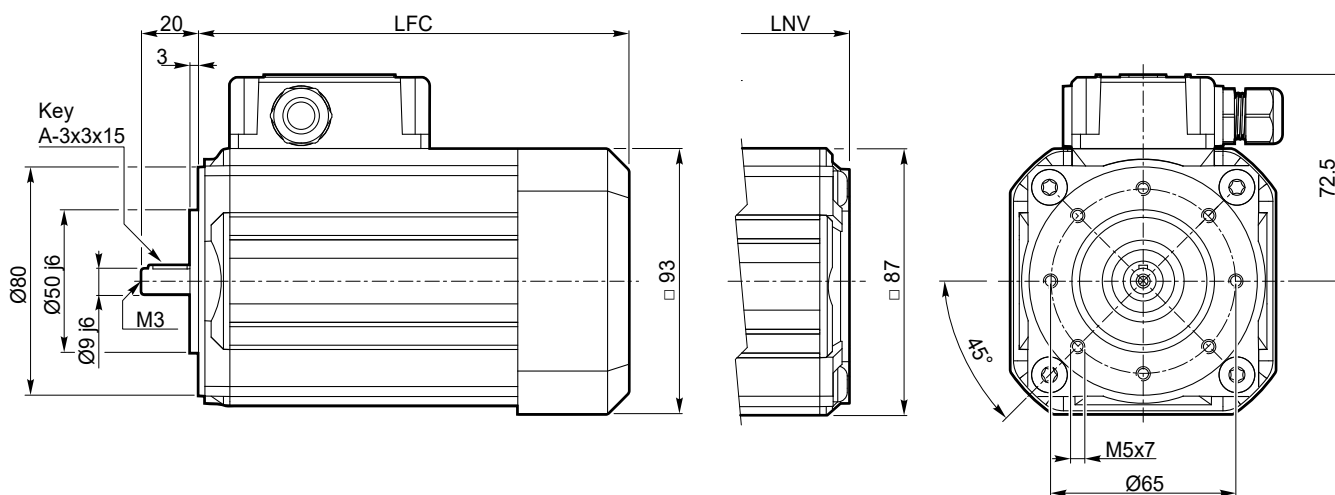

SMM	LFC	LNV
5624	151	127
5634	171	147
5644	206	182

Nota:
il condensatore sarà fornito a corredo

Note:
the capacitor will be supplied separately

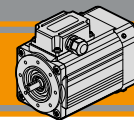

Dimensioni motori monofase

Single phase motors dimensions

SMM63.. - B14 - TEFC

SMM63.. - B14 - TENV S3 ^{servizio} _{duty} 30%

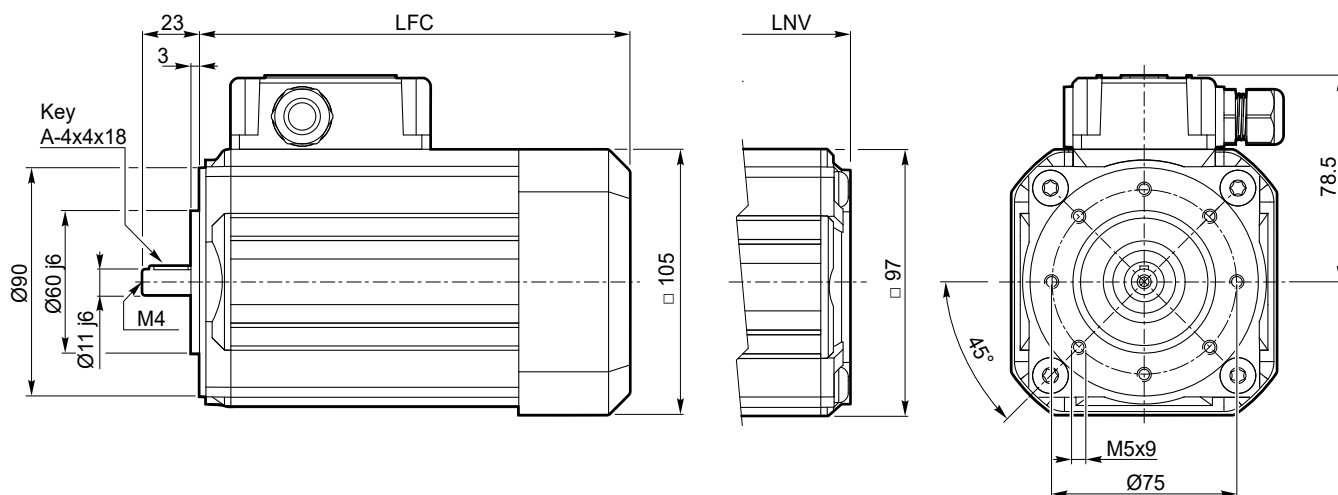

SMM	LFC	LNV
6324	180.5	153.5
6334	205.5	178.5

Nota:
il condensatore sarà fornito a corredo

Note:
the capacitor will be supplied separately

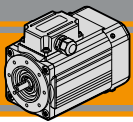

Grado di protezione IP

IP protection rating

Indica il grado di isolamento meccanico del corpo motore.















1ª cifra protezione alla penetrazione di corpi solidi.

2ª cifra protezione contro la penetrazione d'acqua.

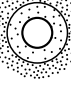
IP protection rating indicates the degree of mechanical insulation of the motor casing.

The 1st figure indicates the level of protection against the intrusion of solid matter.

The 2nd figure indicates to which degree the motor is waterproof.

IP		Definizione / Description	IP		Definizione / Description
0		Non protetto / No protection	0		Non protetto / No protection
1		Protetto da corpi solidi superiori a Ø 50 mm. Protected against solid matter (over Ø 50 mm).	1		Protetto contro la caduta verticale di gocce d'acqua. Protected against drops of water falling vertically.
2		Protetto da corpi solidi superiori a Ø 12 mm. Protected against solid matter (over Ø 12 mm).	2		Protetto contro la caduta verticale di gocce d'acqua con inclinazione max di 15°. Protected against drops of water falling up to 15°.
3		Protetto da corpi solidi superiori a Ø 2.5 mm. Protected against solid matter (over Ø 2.5 mm).	3		Protetto contro la pioggia. Rain proof.
4		Protetto da corpi solidi superiori a Ø 1 mm. Protected against solid matter (over Ø 1 mm).	4		Protetto contro gli spruzzi. Splash proof.
5		Protetto contro la polvere. Dust protected.	5		Protetto contro getti d'acqua. Water jet proof.
6		Totalmente protetto contro la polvere. Fully dust tight.	6		Protetto dalle ondate. Waveproof.
7		N.A.	7		Protetto contro immersione. Immersion up to 1 metre.
8		N.A.	8		Protetto contro immersione/sommersione prolungata. Immersion beyond 1 metre.

Normative di riferimento

Reference standards

	Europe EN	World IEC	Italy CEI
Requisiti generali per macchine elettriche <i>General requirements electrical machines</i>	EN 60034-1:2010	IEC 60034-1:2010	CEI EN 60034-1:2010
Classificazione del grado di protezione <i>Classification degree of protection provided by enclosures</i>	EN 60034-5:2001	IEC 60034-5:2001	CEI EN 60034-5:2001
Sistema di raffreddamento <i>Cooling system</i>	EN 60034-6:1993	IEC 60034-6:1993	CEI EN 60034-6:1993
Modalità di montaggio <i>Mounting arrangements</i>	EN 60034-7:1993	IEC 60034-7:1993	CEI EN 60034-7:1993

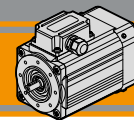
Tipi di servizio IEC
IEC duty cycles

Il servizio di un motore indica il tipo di utilizzo e la gravosità del ciclo di lavoro. Lo stesso motore può funzionare in tutti i servizi, purché si moduli la potenza nominale al fine di consentire il corretto equilibrio termico.

Lo stesso motore è dichiarato per potenze diverse se è diverso il servizio.

The duty cycle of a motor indicates its use and running cycle. The same motor can work under all these conditions by adjusting the rated power in order to maintain the correct temperature balance. The same motor can be declared as having a different power if it has a different duty cycle.

S1	Servizio continuo. Funzionamento a carico costante per una durata sufficiente al raggiungimento dell'equilibrio termico.	Continuous duty. The motor works at a constant load for enough time to reach temperature equilibrium
S2	Servizio di durata limitata. Funzionamento a carico costante per una durata inferiore a quella necessaria al raggiungimento dell'equilibrio termico, seguito da un periodo di riposo tale da riportare il motore alla temperatura ambiente.	Short time duty. The motor works at a constant load, but not long enough to reach temperature equilibrium, and the rest periods are long enough for the motor to reach ambient temperature.
S3	Servizio periodico intermittente. Sequenze di cicli identici di marcia e di riposo a carico costante, senza raggiungimento dell'equilibrio termico. La corrente di spunto ha effetti trascurabili sul surriscaldamento del motore.	Intermittent periodic duty. Sequential, identical run and rest cycles with constant load. Temperature equilibrium is never reached. Starting current has little effect on temperature rise.
S4	Servizio periodico intermittente con avviamento. Sequenza di cicli di funzionamento identici di avviamento, marcia e riposo a carico costante, senza raggiungimento dell'equilibrio termico. La corrente di spunto ha effetti sul riscaldamento del motore.	Intermittent periodic duty with starting. Sequential identical start, run and rest cycles with constant load. Temperature equilibrium is not reached, but starting current affects temperature rise.
S5	Servizio periodico intermittente con frenatura elettrica. Sequenza di cicli di funzionamento identici di avviamento, marcia a carico costante, frenatura elettrica e riposo, senza raggiungimento dell'equilibrio termico.	Intermittent periodic duty with electric braking. Sequential, identical cycles of starting, running at constant load, electric braking and rest. Temperature equilibrium is not reached.
S6	Servizio periodico ininterrotto con carico intermittente. Sequenza di cicli di lavoro identici con carico costante e senza carico. Non ci sono periodi di riposo.	Continuous operation with intermittent load. Sequential, identical cycles of running with constant load and running with no load. No rest periods.
S7	Servizio periodico ininterrotto con frenatura elettrica. Sequenza di cicli di funzionamento identici di avviamento, marcia a carico costante e frenatura elettrica, senza periodi di riposo.	Continuous operation with electric braking. Sequential, identical cycles of starting, running at constant load and electric braking. No rest periods.
S8	Servizio periodico ininterrotto con variazioni di carico e di velocità. Sequenza di cicli identici di avviamento, marcia a carico costante e velocità definita, seguiti da marcia a carico costante e velocità differente dalla precedente. Non ci sono periodi di riposo.	Continuous operation with periodic changes in load and speed. Sequential, identical, duty cycles of start, run at constant load and given speed, then run at other constant loads and speeds. No rest periods.
S9	Servizio con variazioni di carico e velocità non periodiche	Load and speed non periodic variations

AC
Grafico servizi più comuni
Most common services diagram

N = funzionamento / run
 R = riposo / rest

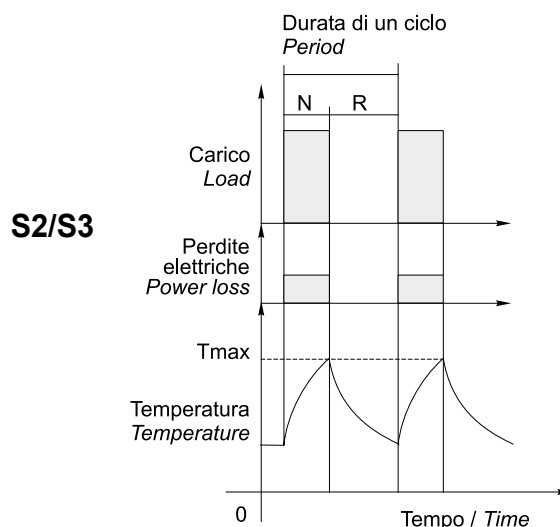
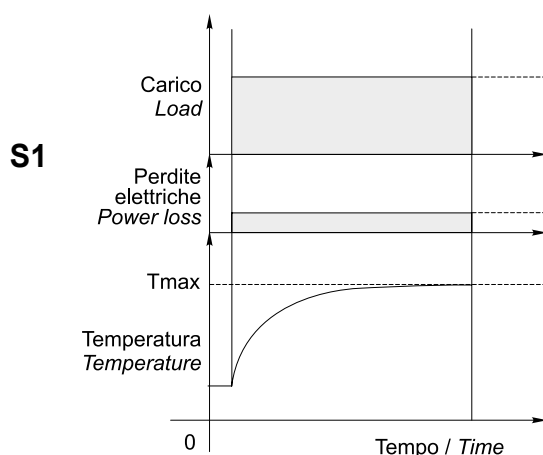

NOTA: Lo stesso motore può essere usato per cicli e servizi diversi, con l'unica limitazione che la temperatura interna non superi mai la Tmax stabilita dalla classe di isolamento termico del motore.

NOTE: The same motor can run under all duty services, limitation is due to internal temperature that must not override Tmax stated by motor thermal class.

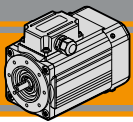

Classe di isolamento termico

Insulation class

La classe termica indica il grado di resistenza alla temperatura interna, nel punto più caldo (avvolgimenti). Maggiore il carico e migliore deve essere il livello di protezione. Attiene alle resine e in generale a tutti i materiali interni di isolamento.

Thermal insulation class indicates the level of thermal protection measured at the hottest point inside the motor (windings). The bigger the load, the more thermal insulation is required. This is related to resin and all the internal insulation materials.

Classe Class	Massima temperatura interna Max. windings temp.
E	120°C
B	130°C
F	155°C
H	180°C

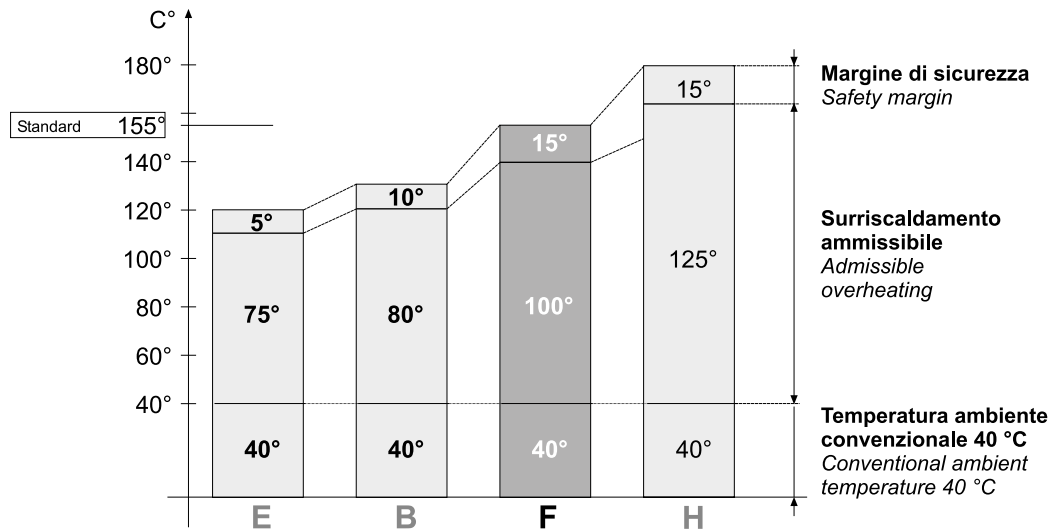

Serie SM - Funzionamento in ambiente 60 Hz

Series SM - 60 Hz line power supply

In via teorica il motore 400 V 50 Hz può essere alimentato a 60 Hz con le seguenti conseguenze:

Theoretically a 400 V 50 Hz motor can run under 60 Hz however with the following consequences:

- La velocità aumenta del 20 % perché dipendente direttamente dalla frequenza.
- La coppia modifica in funzione della tensione (infatti il rapporto tensione/frequenza è proporzionale al flusso magnetico ammesso).
A 400 V la coppia cala di circa il 20% mentre la potenza rimane invariata.
A 480 V la coppia rimane invariata e la potenza aumenta del 20% circa.
Valori intermedi di tensione producono effetti intermedi.

- *20% speed increase as it depends on the frequency.*
- *Varied torque as it depends on the voltage (ratio Volt/Hertz is proportional to the available magnetic flux).*

With 400 Vac, torque decreases about 20% but the power remains the same.

With 480 Vac, torque remains the same and the power increases 20%.

Mean voltage gives mean results.

	50 Hz	60 Hz
400 V	standard	Velocità / speed ≈ + 20% Coppia / torque ≈ -20% Potenza / power ≈ invariata / the same
480 V	Velocità / speed ≈ invariata / the same Coppia / torque - potenza / power ≈ +20% Attenzione, perdite e surriscaldamento Take care of losses and overheating	Velocità / speed ≈ + 20% Coppia / torque ≈ invariata / the same Potenza / power ≈ + 20%

MINI 
TECNO
small but strong

CMG

AC

Motoriduttori CA ad ingranaggi cilindrici
AC Helical in-line gearmotors



MINI 
TECNO brand of
TRANSTECNO®



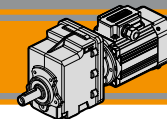

Indice	Index	Pag. Page
Caratteristiche tecniche	<i>Technical features</i>	AB2
Designazione	<i>Classification</i>	AB2
Sensi di rotazione	<i>Direction of rotation</i>	AB3
Lubrificazione	<i>Lubrication</i>	AB3
Simbologia	<i>Symbols</i>	AB3
Carichi radiali	<i>Radial loads</i>	AB3
Motori applicabili	<i>IEC Motor adapters</i>	AB4
Dati tecnici	<i>Technical data</i>	AB4
Dimensioni	<i>Dimensions</i>	AB6

Questa sezione annulla e sostituisce ogni precedente edizione o revisione. Qualora questa sezione non Vi sia giunta in distribuzione controllata, l'aggiornamento dei dati ivi contenuto non è assicurato. **In tal caso la versione più aggiornata è disponibile sul nostro sito internet www.transtecno.com**

This section replaces any previous edition and revision. If you obtained this catalogue other than through controlled distribution channels, the most up to date content is not guaranteed. In this case the latest version is available on our web site www.transtecno.com

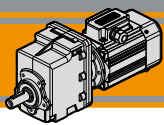

Caratteristiche tecniche

Technical features

Le caratteristiche principali dei motoriduttori CMG sono:

CMG gearmotor range has the following main features:

- Costruzione compatta
- Motorizzazioni in corrente alternata monofase e trifase
- Carcassa motore estrusa in alluminio anodizzato nero
- Carcasse dei riduttori in pressofusione di alluminio
- Motore elettrico AC con grado di protezione IP66
- Lubrificazione permanente con olio sintetico
- Ingranaggi cilindrici a denti elicoidali, induriti e rettificati
- Disponibili sia nella versione ventilata TEFC (servizio S1) che non ventilata TENV (servizio S3)
- Protezioni termiche per le taglie 56 e 63
- SMT56 e SMT63 adatti al funzionamento con alimentazione da inverter

- Compact design
- AC single phase and three phase motors available
- Motor extruded aluminum housing black anodized
- Gearbox die-cast aluminum housing
- AC electric motor in IP66 protection Standard
- Permanent synthetic oil long-life lubrication
- Ground-hardened helical gears
- Fan cooled TEFC (duty S1) and not ventilated TENV (duty S3) versions available
- Thermal protection for motor sizes 56 and 63
- SMT56 and SMT63 are suitable for running with inverter

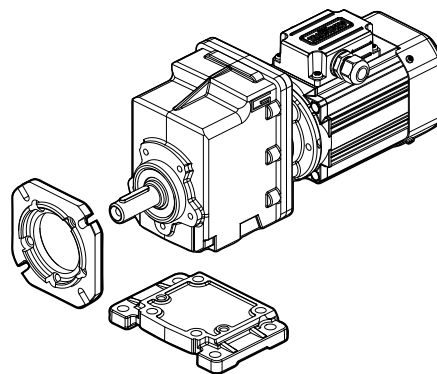

Designazione

Classification

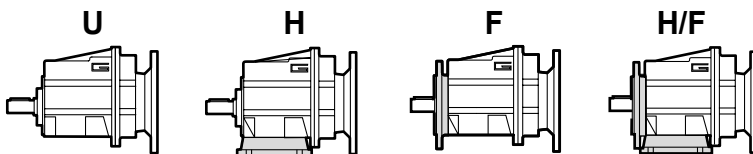

RIDUTTORE / GEARBOX

CMG	00	2	H60	10.16	D20	63	B14
Tipo Type	Grandezza Size	Stadi Stages	Versione Version	Rapporto Ratio	Albero uscita Output shaft	IEC 	Forma costruttiva Version
CMG	00	2 3	U... H... F... H.../F...	vedi tabelle see tables	vedi tabelle see tables	56.. 63..	B14

SMT	63	2	4	B14	230-400 V	50 Hz	TEFC	T1
Tipo Type	Grandezza Size	Indicativo potenza Power coefficient	Poli Poles	Forma costruttiva Version	Tensione Voltage	Frequenza Frequency	Ventilazione Fan cooling	Pos. morsettieria Terminal box pos.
SMT trifase threephase	vedi tabelle see tables	1-2-3-4-5	4	B14	230-400 V	50Hz 60Hz	TEFC TENV	T1 (Std)

SMM	63	2	4	B14	230 V	50 Hz	TEFC	T1
Tipo Type	Grandezza Size	Indicativo potenza Power coefficient	Poli Poles	Forma costruttiva Version	Tensione Voltage	Frequenza Frequency	Ventilazione Fan cooling	Pos. morsettieria Terminal box pos.
SMM monofase singlephase	vedi tabelle see tables	1-2-3-4	4	B14	230 V	50Hz	TEFC TENV	T1 (Std)

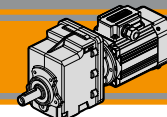

Sensi di rotazione

Direction of rotation

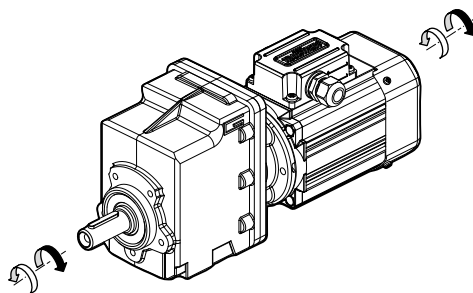

Lubrificazione

Lubrication

Tutti i riduttori sono forniti completi di lubrificante sintetico viscosità 320, pertanto possono essere installati in qualunque posizione di montaggio e non necessitano di manutenzione.

Permanent synthetic oil long-life lubrication (viscosity grade 320) makes it possible to use in all mounting positions; for this reason they can be installed in any assembly position and do not require maintenance.

Simbologia

Symbols

- n_1 [min⁻¹] Velocità in ingresso / Input speed
- n_2 [min⁻¹] Velocità in uscita / Output speed
- i Rapporto di riduzione / Ratio
- P_1 [kW] Potenza in entrata / Input power
- M_2 [Nm] Coppia nominale in uscita in funzione di P_1 / Output torque referred to P_1
- sf Fattore di servizio / Service factor
- R_2 [N] Carico radiale ammissibile in uscita / Permitted output radial load
- A_2 [N] Carico assiale ammissibile in uscita / Permitted output axial load

Carichi radiali

Radial loads

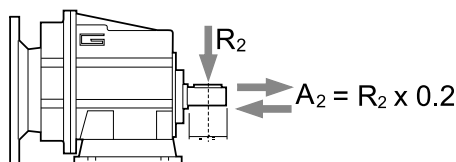

	CMG 002												
n_2 [min ⁻¹]	700	600	500	400	250	180	150	120	100	80	60	40	10
R_2 [N]	416	437	465	501	586	653	748	806	958	1032	1136	1300	1300

Quando il carico radiale risultante non è applicato sulla mezzeria dell'albero occorre calcolare quello effettivo con la seguente formula:

When the resulting radial load is not applied on the centre line of the shaft it is necessary to calculate the effective load with the following formula:

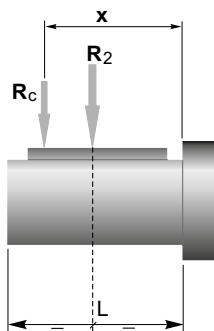

	CMG 002
a	73
b	53
R_{2MAX}	1300

$$R_c = \frac{R_2 \cdot a}{(b+x)} \leq R_{2MAX}$$

$$R \leq R_c$$

$a, b =$ valori riportati nella tabella
 $a, b =$ values given in the table

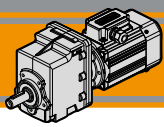

CMG

Motoriduttori CA ad ingranaggi cilindrici
AC Helical in-line gearmotors



Motori applicabili

IEC Motor adapters

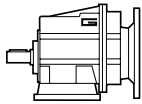
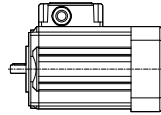

		SMT			SMM		
		5014 5024 5034 5044	5624 5634 5644 5654	6324 6334 6344	5014 5024 5034	5624 5634 5644	6324 6334
CMG	002	5.03 - 55.10					

5.03 - 55.10

Rapporti di riduzione i
Ratio i

Dati tecnici



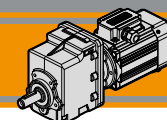

Technical data

P ₁ [kW]	n ₂ [min ⁻¹]	M ₂ [Nm]	sf	i			P ₁ [kW]	n ₂ [min ⁻¹]	M ₂ [Nm]	sf	i		
0.04							0.09						
SMT5014	279	1	30.4	5.03	CMG002	B14	SMT5034	279	3	13.5	5.03	CMG002	B14
SMM5014	230	2	25.0	6.10			SMM5034	230	4	11.1	6.10		
(1400 min ⁻¹)	187	2	20.4	7.49			SMT5624	187	4	9.1	7.49		
	156	2	21.2	8.99			SMM5624	156	5	9.4	8.99		
	138	3	18.8	10.16			(1400 min ⁻¹)	138	6	8.3	10.16		
	116	3	15.8	12.07				116	7	7.0	12.07		
	105	4	20.0	13.40				105	8	8.9	13.40		
	92	4	17.7	15.14				92	9	7.8	15.14		
	77	5	14.7	18.17				77	11	6.5	18.17		
	65	6	12.4	21.58				65	13	5.5	21.58		
	60	6	11.4	23.51				60	14	5.1	23.51		
	56	7	10.6	25.10				56	15	4.7	25.10		
	52	7	9.9	27.08				52	16	4.4	27.08		
	43	9	8.2	32.49				43	19	3.7	32.49		
	33	11	6.4	42.04				33	25	2.8	42.04		
	31	12	6.0	44.89				31	26	2.6	44.89		
	29	13	5.5	48.86		29	29	2.4	48.86				
	25	14	4.8	55.10		25	32	2.2	55.10				
0.06							0.12						
SMT5024	279	2	20.3	5.03	CMG002	B14	SMT5044	279	4	10.1	5.03	CMG002	B14
SMM5024	230	2	16.7	6.10			SMT5634	230	5	8.3	6.10		
(1400 min ⁻¹)	187	3	13.6	7.49			SMM5634	187	6	6.8	7.49		
	156	4	14.2	8.99			(1400 min ⁻¹)	156	7	7.1	8.99		
	138	4	12.5	10.16				138	8	6.3	10.16		
	116	5	10.5	12.07				116	9	5.3	12.07		
	105	5	13.3	13.40				105	11	6.7	13.40		
	92	6	11.8	15.14				92	12	5.9	15.14		
	77	7	9.8	18.17				77	14	4.9	18.17		
	65	8	8.3	21.58				65	17	4.1	21.58		
	60	9	7.6	23.51				60	18	3.8	23.51		
	56	10	7.1	25.10				56	20	3.5	25.10		
	52	11	6.6	27.08				52	21	3.3	27.08		
	43	13	5.5	32.49				43	26	2.7	32.49		
	33	17	4.2	42.04				33	33	2.1	42.04		
	31	18	4.0	44.89				31	35	2.0	44.89		
	29	19	3.6	48.86		29	38	1.8	48.86				
	25	22	3.2	55.10		25	43	1.6	55.10				

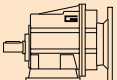

Dati tecnici

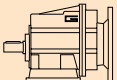
Technical data

P_1 [kW]	n_2 [min ⁻¹]	M_2 [Nm]	sf	i			P_1 [kW]	n_2 [min ⁻¹]	M_2 [Nm]	sf	i		
---------------	-------------------------------	---------------	----	---	---	---	---------------	-------------------------------	---------------	----	---	---	---

0.18

SMT5644	279	6	6.8	5.03	CMG002	B14
SMM5644	230	7	5.6	6.10		B14
SMT6324	187	9	4.5	7.49		B14
SMM6324	156	11	4.7	8.99		B14
(1400 min ⁻¹)	138	12	4.2	10.16		B14
	116	14	3.5	12.07		B14
	105	16	4.4	13.40		B14
	92	18	3.9	15.14		B14
	77	21	3.3	18.17		B14
	65	25	2.8	21.58		B14
	60	28	2.5	23.51		B14
	56	30	2.4	25.10		B14
	52	32	2.2	27.08		B14
	43	38	1.8	32.49		B14
	33	50	1.4	42.04		B14
	31	53	1.3	44.89		B14
	29	58	1.2	48.86	B14	
	25	65	1.1	55.10	B14	

0.37

SMT6344	279	12	3.3	5.03	CMG002	B14
(1400 min ⁻¹)	230	15	2.7	6.10		B14
	187	18	2.2	7.49		B14
	156	22	2.3	8.99		B14
	138	25	2.0	10.16		B14
	116	29	1.7	12.07		B14
	105	32	2.2	13.40		B14
	92	37	1.9	15.14		B14
	77	44	1.6	18.17		B14
	65	52	1.3	21.58		B14
	60	57	1.2	23.51		B14
	56	61	1.2	25.10		B14
	52	66	1.1	27.08		B14
	43	79	0.9	32.49		B14

0.25

SMT5654	279	8	4.9	5.03	CMG002	B14
SMT6334	230	10	4.0	6.10		B14
SMM6334	187	12	3.3	7.49		B14
(1400 min ⁻¹)	156	15	3.4	8.99		B14
	138	17	3.0	10.16		B14
	116	20	2.5	12.07		B14
	105	22	3.2	13.40		B14
	92	25	2.8	15.14		B14
	77	30	2.4	18.17		B14
	65	35	2.0	21.58		B14
	60	38	1.8	23.51		B14
	56	41	1.7	25.10		B14
	52	44	1.6	27.08		B14
	43	53	1.3	32.49		B14
	33	69	1.0	42.04		B14
	31	73	1.0	44.89		B14
	29	80	0.9	48.86	B14	
	25	90	0.8	55.10	B14	

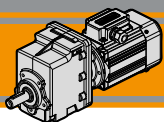

CMG

Motoriduttori CA ad ingranaggi cilindrici
AC Helical in-line gearmotors



Dimensioni

Dimensions

CMG 002 U

CMG 002 U

SMT50...TEFC
SMM50... TEFC

SMT50...TENV
SMM50... TENV

S3 servizio 30%
duty

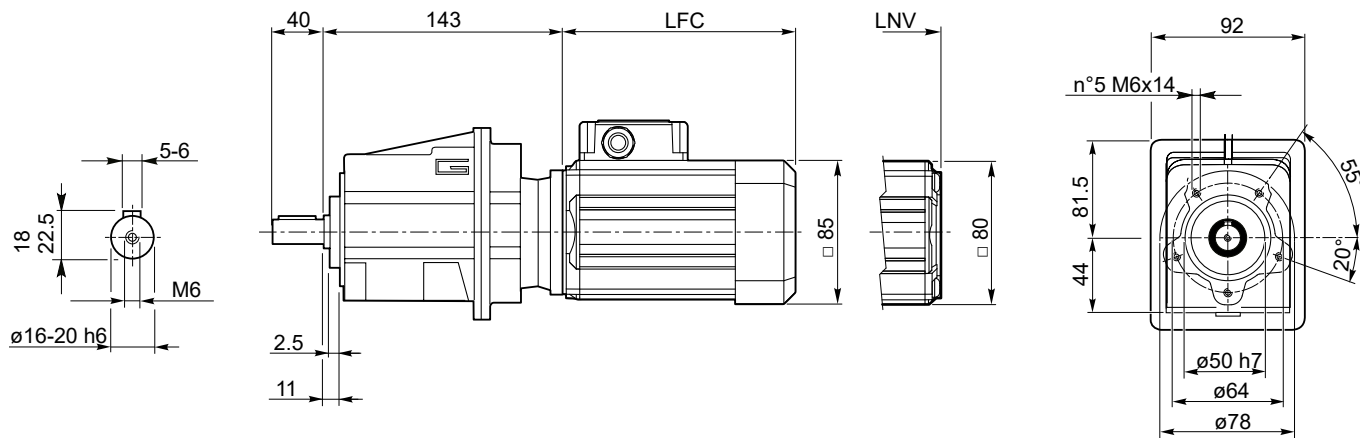

SMT	LFC	LNV	Kg	
5014	135.5	108.5	5.2	
5024	150.5	123.5	5.6	
5034	175.5	148.5	6.4	
5044	200.5	173.5	7.1	

SMM	LFC	LNV	Kg	
5014	150.5	123.5	5.6	
5024	175.5	148.5	6.4	
5034	200.5	173.5	7.1	

Nota: il condensatore sarà fornito a corredo
Note: the capacitor will be supplied separately

CMG...H → AB8

CMG...F → AB8

CMG...H/F → AB9

CMG 002 U

SMT56...TEFC
SMM56... TEFC

SMT56...TENV
SMM56... TENV

S3 servizio 30%
duty

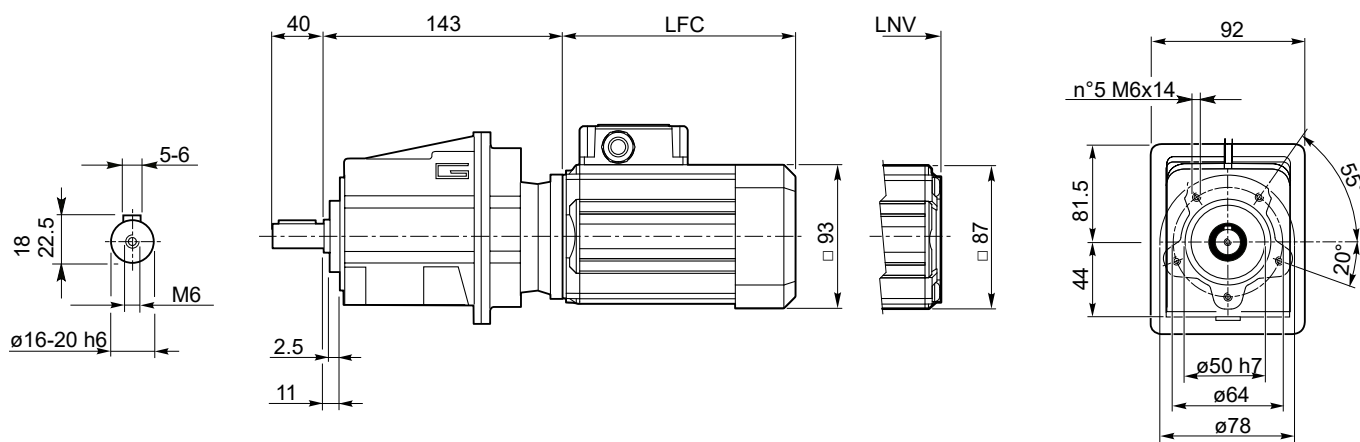

SMT	LFC	LNV	Kg	
5624	141	117	5.7	
5634	151	127	6.1	
5644	186	162	7.3	
5654	206	182	8	

SMM	LFC	LNV	Kg	
5624	151	127	6	
5634	171	147	6.6	
5644	206	182	7.9	

Nota: il condensatore sarà fornito a corredo
Note: the capacitor will be supplied separately

CMG...H → AB8

CMG...F → AB8

CMG...H/F → AB9

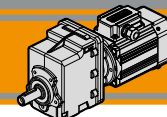

Dimensioni

Dimensions

CMG 002 U

CMG 002 U

SMT63...TEFC
SMM63... TEFC

SMT63...TENV
SMM63... TENV

S3 servizio 30%
duty

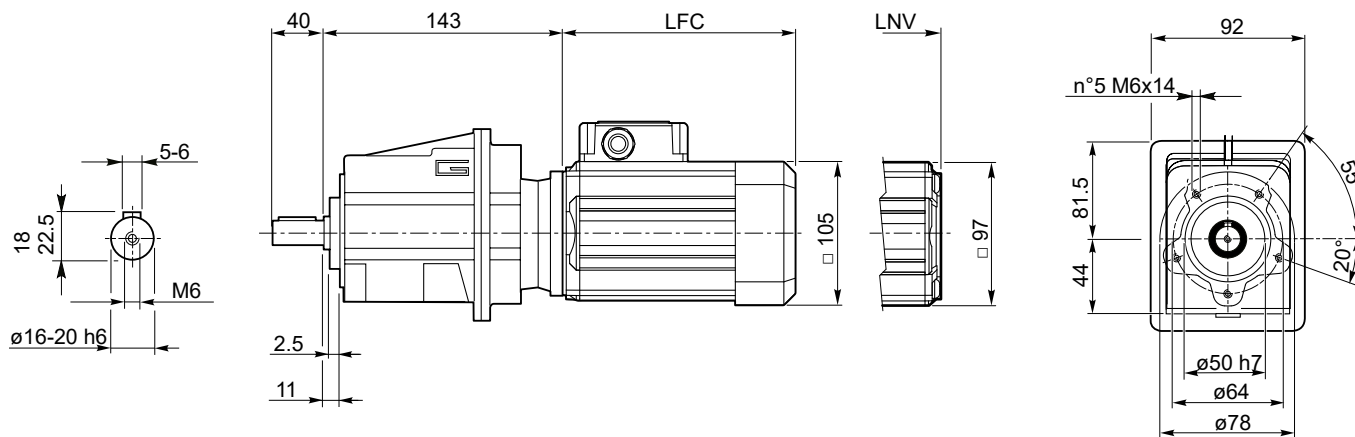

SMT	LFC	LNV	
6324	165.5	138.5	7.2
6334	180.5	153.5	7.9
6344	205.5	178.5	9.1

SMM	LFC	LNV	
6324	180.5	153.5	8
6334	205.5	178.5	9.2

Nota: il condensatore sarà fornito a corredo
Note: the capacitor will be supplied separately

CMG...H →

CMG...F →

CMG...H/F →

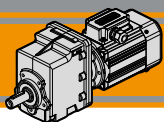

CMG

Motoriduttori CA ad ingranaggi cilindrici
AC Helical in-line gearmotors



Dimensioni

Dimensions

CMG..H

CMG002 H..

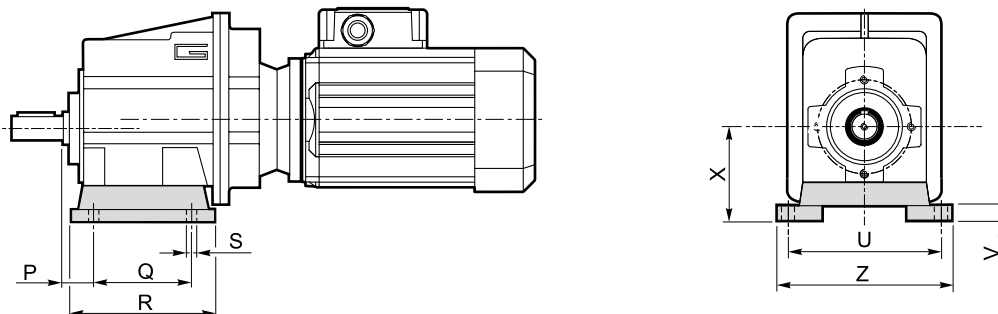

Versione H / H Version										
CMG	P	Q	R	S	U	V	X	Z	Piede / Foot	
									Tipo / Type	Peso / Weight [kg]
002	18	60	80	9	100	10	60	120	H60	0.2
	18	80	104	9	110 - 120	10	75	145	H75	0.3
	18	50 - 87	110	9	110	10	85	135	H85	0.4

Preferenziale / Preferred

CMG..F

CMG002 F..

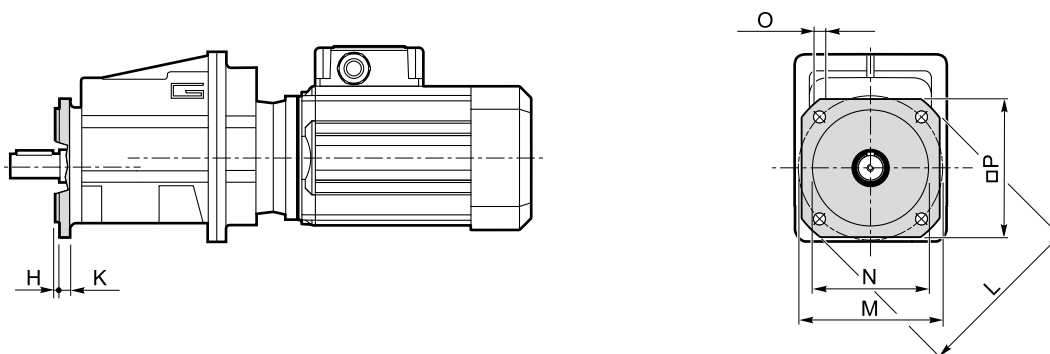

Versione F / F Version										
CMG	H	K	L	M	N f7	O	P	Flangia / Flange		
								Tipo / Type	Peso / Weight [kg]	
002	3.5	7	105	85	70	6.5	90	F105	0.1	
	3.5	8	120	100	80	7	100	F120	0.2	
	3.5	8	140	115	95	9	115	F140	0.2	

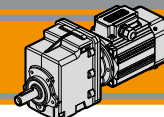

Dimensioni

Dimensions

CMG..H../F..

CMG002 H../F..

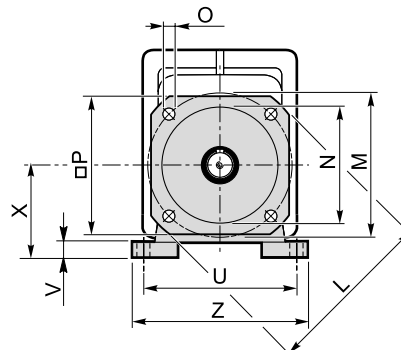
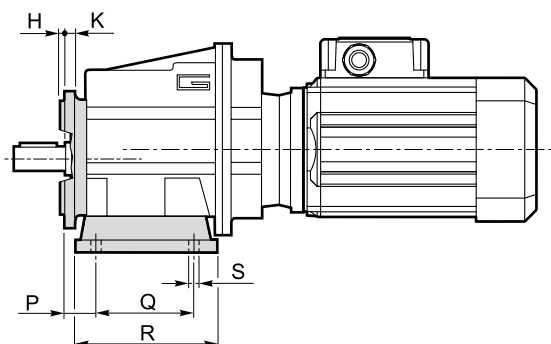

Versione H / H Version										Combinazioni possibili H/F Possible combinations H/F							
CMG	P	Q	R	S	U	V	X	Z	Piede / Foot		F105	F120	F140	F160	F200	F250	F300
									Tipo / Type	Peso / Weight [kg]							
002	18	60	80	9	100	10	60	120	H60	0.2	•	•	•				
	18	80	104	9	110 - 120	10	75	145	H75	0.3	•	•	•				
	18	50 - 87	110	9	110	10	85	135	H85	0.4	•	•	•				

Preferenziale / Preferred

• Combinazioni possibili H/F / Possible combinations H/F

Versione F / F Version									
CMG	H	K	L	M	N f7	O	P	Flangia / Flange	
								Tipo / Type	Peso / Weight [kg]
002	3.5	7	105	85	70	6.5	90	F105	0.1
	3.5	8	120	100	80	7	100	F120	0.2
	3.5	8	140	115	95	9	115	F140	0.2

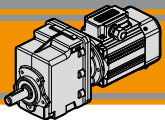

CMG

Motoriduttori CA ad ingranaggi cilindrici
AC Helical in-line gearmotors

MINI
TECNO

Note/Notes

Motoriduttori CA ad assi ortogonali
AC Helical bevel gearmotors

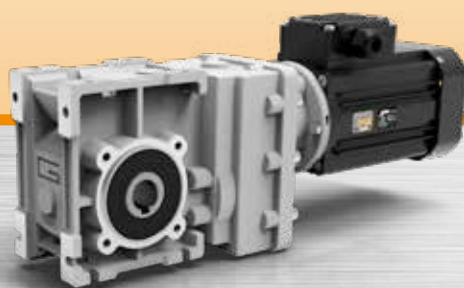

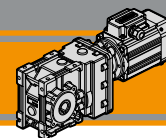

Indice	Index	Pag. Page
Caratteristiche tecniche	<i>Technical features</i>	AC2
Designazione	<i>Classification</i>	AC2
Sensi di rotazione	<i>Direction of rotation</i>	AC3
Simbologia	<i>Symbols</i>	AC3
Lubrificazione	<i>Lubrication</i>	AC3
Carichi radiali	<i>Radial loads</i>	AC3
Motori applicabili	<i>Motor adapters</i>	AC4
Dati tecnici	<i>Technical data</i>	AC4
Dimensioni	<i>Dimensions</i>	AC6
Accessori	<i>Accessories</i>	AC8

Questa sezione annulla e sostituisce ogni precedente edizione o revisione. Qualora questa sezione non Vi sia giunta in distribuzione controllata, l'aggiornamento dei dati ivi contenuto non è assicurato. **In tal caso la versione più aggiornata è disponibile sul nostro sito internet www.transtecno.com**

This section replaces any previous edition and revision. If you obtained this catalogue other than through controlled distribution channels, the most up to date content is not guaranteed. In this case the latest version is available on our web site www.transtecno.com

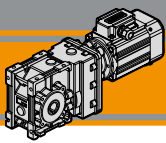

CMB

Motoriduttori CA ad assi ortogonali
AC Helical bevel gearmotors



Caratteristiche tecniche

Technical features

Le caratteristiche principali dei motoriduttori CMB sono:

CMB gearmotor range has the following main features:

- Costruzione compatta
- Motorizzazioni in corrente alternata monofase e trifase
- Carcassa motore estrusa in alluminio anodizzato nero
- Carcasse dei riduttori in pressofusione di alluminio
- Motore elettrico AC con grado di protezione IP66
- Lubrificazione permanente con olio sintetico
- Ingranaggi cilindrici a denti elicoidali, induriti e rettificati
- Disponibili sia nella versione ventilata TEFC (servizio S1) che non ventilata TENV (servizio S3)
- Protezioni termiche per le taglie 56 e 63
- SMT56 e SMT63 adatti al funzionamento con alimentazione da inverter

- Compact design
- AC single phase and three phase motors available
- Motor extruded aluminum housing black anodized
- Gearbox die-cast aluminum housing
- AC electric motor in IP66 protection Standard
- Permanent synthetic oil long-life lubrication
- Ground-hardened helical gears
- Fan cooled TEFC (duty S1) and not ventilated TENV (duty S3) versions available
- Thermal protection for motor sizes 56 and 63
- SMT56 and SMT63 are suitable for running with inverter

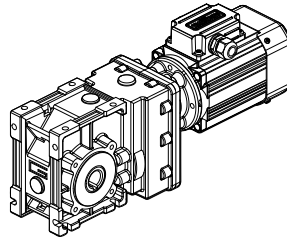

Designazione

Classification

RIDUTTORE / GEARBOX										
CMB	40 2		U	9.81	D20	63	B14	SZDX	BR SX	90
Tipo Type	Grandezza Size	Stadi Stages	Versione Version	Rapporto Ratio	Albero cavo uscita Hollow output shaft	IEC	Forma costruttiva Version	Albero di uscita Output shaft	Braccio di reazione Torque arm	Angolo Angle
	40	2	U FD FS FBD FBS FLD FLS	vedi tabelle see tables	vedi tabelle see tables	IEC 56.. 63..	B14	SZDX SZSX DZ	BRDX BR SX *	0° 90° 180° 270°
Versione Riduttore Gearbox Version			Albero di uscita Output shaft			Braccio di reazione Torque arm *		Angolo Angle		

* NOTA: il braccio di reazione viene fornito smontato.
NOTE: the torque arm will be supplied not assembled.

SMT	63	2	4	B14	230-400 V	50 Hz	TEFC	T1
Tipo Type	Grandezza Size	Indicativo potenza Power coefficient	Poli Poles	Forma costruttiva Version	Tensione Voltage	Frequenza Frequency	Ventilazione Fan cooling	Pos. morsetteria Terminal box pos.
SMT trifase threephase	vedi tabelle see tables	1-2-3-4-5	4	B14	230-400 V	50Hz 60Hz	TEFC TENV	T1 (Std) T4 T2 T3
SMM	63	2	4	B14	230 V	50 Hz	TEFC	T1
Tipo Type	Grandezza Size	Indicativo potenza Power coefficient	Poli Poles	Forma costruttiva Version	Tensione Voltage	Frequenza Frequency	Ventilazione Fan cooling	Pos. morsetteria Terminal box pos.
SMM monofase singlephase	vedi tabelle see tables	1-2-3-4	4	B14	230 V	50Hz	TEFC TENV	T1 (Std) T4 T2 T3

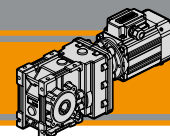

Sensi di rotazione

Direction of rotation

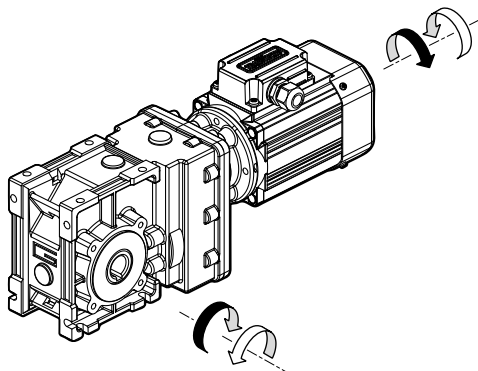

Simbologia

Symbols

n_1 [min ⁻¹]	Velocità in ingresso / <i>Input speed</i>	M_2 [Nm]	Coppia in uscita in funzione di P_1 / <i>Output torque referred to P_1</i>
n_2 [min ⁻¹]	Velocità in uscita / <i>Output speed</i>	sf	Fattore di servizio / <i>Service factor</i>
i	Rapporto di riduzione / <i>Ratio</i>	A_2 [N]	Carico assiale ammissibile in uscita / <i>Permitted output axial load</i>
P_1 [kW]	Potenza in entrata / <i>Input power</i>	R_2 [N]	Carico radiale ammissibile in uscita / <i>Permitted output radial load</i>

Lubrificazione

Lubrication

Tutti i riduttori nelle taglie 402 sono forniti completi di lubrificante sintetico viscosità 320, pertanto possono essere installati in qualunque posizione di montaggio e non necessitano di manutenzione.

Permanent synthetic oil long-life lubrication (viscosity grade 320) makes it possible to use sizes 402 in all mounting positions; for this reason they can be installed in any assembly position and do not require maintenance.

Carichi radiali

Radial loads

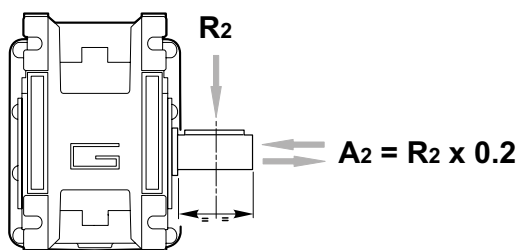

n_2 [min ⁻¹]	R_2 [N]
	CMB 402
400	905
300	996
200	1141
170	1204
140	1414
100	1582
90	1638
60	2047
40	2524
30	2778
20	3180
15	3500
10	3500

Quando il carico radiale risultante non è applicato sulla mezza-ria dell'albero occorre calcolare quello effettivo con la seguente formula:

When the resulting radial load is not applied on the centre line of the shaft it is necessary to calculate the effective load with the following formula:

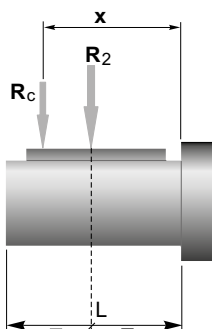

	CMB 402
a	86
b	66
R_{2MAX}	3500

$$R_c = \frac{R_2 \cdot a}{(b+x)} \leq R_{2MAX}$$

$$R \leq R_c$$

*a, b = valori riportati nella tabella
a, b = values given in the table*

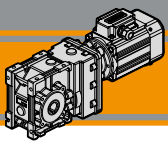

CMB

Motoriduttori CA ad assi ortogonali
AC Helical bevel gearmotors



Motori applicabili

Motor adapters

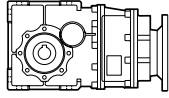
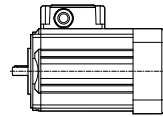

		SMT			SMM		
		5014 5024 5034 5044	5624 5634 5644 5654	6324 6334 6344	5014 5024 5034	5624 5634 5644	6324 6334
CMB	002	6.18 - 72.50					

6.18 - 72.50

Rapporti di riduzione i
Ratio i

Dati tecnici



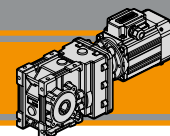

Technical data

P_1 [kW]	n_2 [min ⁻¹]	M_2 [Nm]	sf	i			P_1 [kW]	n_2 [min ⁻¹]	M_2 [Nm]	sf	i		
0.04							0.06						
SMT5014	227	2	25.3	6.18	CMB402	B14	SMT5024	227	2	16.8	6.18	CMB402	B14
SMM5014	187	2	20.8	7.49			SMM5024	187	3	13.9	7.49		
(1400 min ⁻¹)	152	2	16.9	9.20			(1400 min ⁻¹)	152	4	11.3	9.20		
	118	3	14.8	11.83				118	5	9.9	11.83		
	112	3	14.1	12.48				112	5	9.4	12.48		
	94	4	11.8	14.83				94	6	7.9	14.83		
	79	5	10.0	17.63				79	7	6.6	17.63		
	75	5	11.5	18.60				75	7	7.7	18.60		
	63	6	9.6	22.33				63	9	6.4	22.33		
	59	6	9.0	23.91				59	9	6.0	23.91		
	48	7	8.8	28.89				48	11	5.8	28.89		
	45	8	8.2	30.84				45	12	5.5	30.84		
	42	9	7.5	33.57				42	13	5.0	33.57		
	39	9	7.1	35.63				39	14	4.7	35.63		
	33	11	5.9	42.75				33	16	4.0	42.75		
	25	14	4.6	55.31				25	21	3.1	55.31		
	24	15	4.3	59.06		24	23	2.9	59.06				
	22	16	3.9	64.29		22	25	2.6	64.29				
	19	19	3.5	72.50		19	28	2.3	72.50				

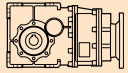

Dati tecnici

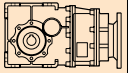
Technical data

P_1 [kW]	n_2 [min ⁻¹]	M_2 [Nm]	sf	i			P_1 [kW]	n_2 [min ⁻¹]	M_2 [Nm]	sf	i		
0.09							0.18						
SMT5034	227	4	11.2	6.18	CMB402	B14	SMT5644	227	7	5.6	6.18	CMB402	B14
SMM5034	187	4	9.3	7.49			SMM5644	187	9	4.6	7.49		
SMT5624	152	5	7.5	9.20			SMT6324	152	11	3.8	9.20		
SMM5624	118	7	6.6	11.83			SMM6324	118	14	3.3	11.83		
(1400 min ⁻¹)	112	7	6.2	12.48			(1400 min ⁻¹)	112	14	3.1	12.48		
	94	9	5.3	14.83				94	17	2.6	14.83		
	79	10	4.4	17.63				79	20	2.2	17.63		
	75	11	5.1	18.60				75	21	2.6	18.60		
	63	13	4.3	22.33				63	26	2.1	22.33		
	59	14	4.0	23.91				59	28	2.0	23.91		
	48	17	3.9	28.89				48	33	1.9	28.89		
	45	18	3.7	30.84				45	36	1.8	30.84		
	42	19	3.4	33.57				42	39	1.7	33.57		
	39	21	3.2	35.63				39	41	1.6	35.63		
	33	25	2.6	42.75				33	49	1.3	42.75		
	25	32	2.0	55.31				25	64	1.0	55.31		
	24	34	1.9	59.06				24	68	0.95	59.06		
	22	37	1.8	64.29		22	74	0.88	64.29				
	19	42	1.6	72.50		19	84	0.8	72.50				

0.12							0.25						
SMT5044	227	5	8.4	6.18	CMB402	B14	SMT5654	227	10	4.0	6.18	CMB402	B14
SMT5634	187	6	6.9	7.49			SMT6334	187	12	3.3	7.49		
SMM5634	152	7	5.6	9.20			SMM6334	152	15	2.7	9.20		
(1400 min ⁻¹)	118	9	4.9	11.83			(1400 min ⁻¹)	118	19	2.4	11.83		
	112	10	4.7	12.48				112	20	2.2	12.48		
	94	11	3.9	14.83				94	24	1.9	14.83		
	79	14	3.3	17.63				79	28	1.6	17.63		
	75	14	3.8	18.60				75	30	1.8	18.60		
	63	17	3.2	22.33				63	36	1.5	22.33		
	59	18	3.0	23.91				59	38	1.4	23.91		
	48	22	2.9	28.89				48	46	1.4	28.89		
	45	24	2.7	30.84				45	49	1.3	30.84		
	42	26	2.5	33.57				42	54	1.2	33.57		
	39	27	2.4	35.63				39	57	1.1	35.63		
	33	33	2.0	42.75				33	69	0.9	42.75		
	25	43	1.5	55.31									
	24	45	1.4	59.06									
	22	49	1.3	64.29									
	19	56	1.2	72.50									

0.37						
SMT6344	227	15	2.7	6.18	CMB402	B14
(1400 min ⁻¹)	187	18	2.3	7.49		
	152	22	1.8	9.20		
	118	28	1.6	11.83		
	112	30	1.5	12.48		
	94	35	1.3	14.83		
	79	42	1.1	17.63		
	75	44	1.2	18.60		
	63	53	1.0	22.33		
	59	57	1.0	23.91		
	48	69	0.9	28.89		
	45	73	0.9	30.84		
	42	80	0.8	33.57		

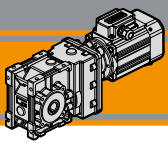

Dimensioni

Dimensions

CMB 402 U

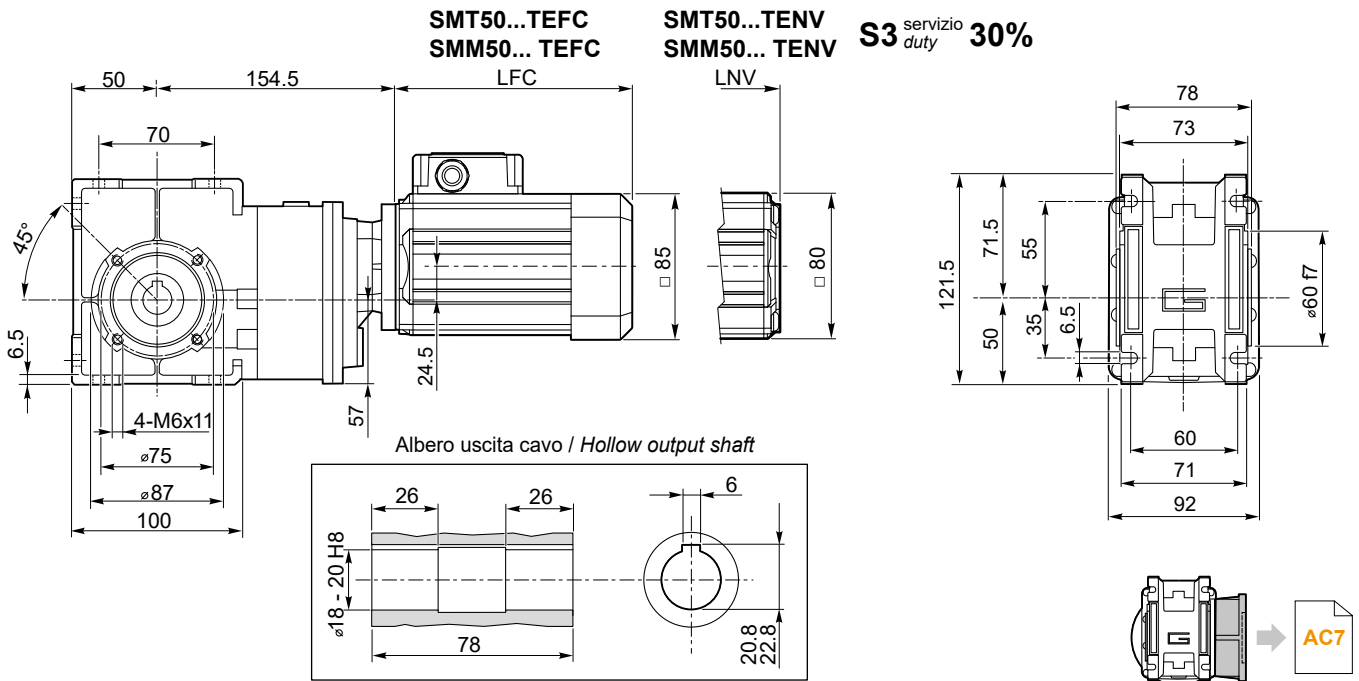

SMT	LFC	LNV	Kg	
5014	135.5	108.5	5.7	
5024	150.5	123.5	6.1	
5034	175.5	148.5	6.9	
5044	200.5	173.5	7.6	

SMM	LFC	LNV	Kg	
5014	150.5	123.5	6.1	
5024	175.5	148.5	6.9	
5034	200.5	173.5	7.6	

Nota:
il condensatore sarà fornito a corredo

Note:
the capacitor will be supplied separately

CMB 402 U

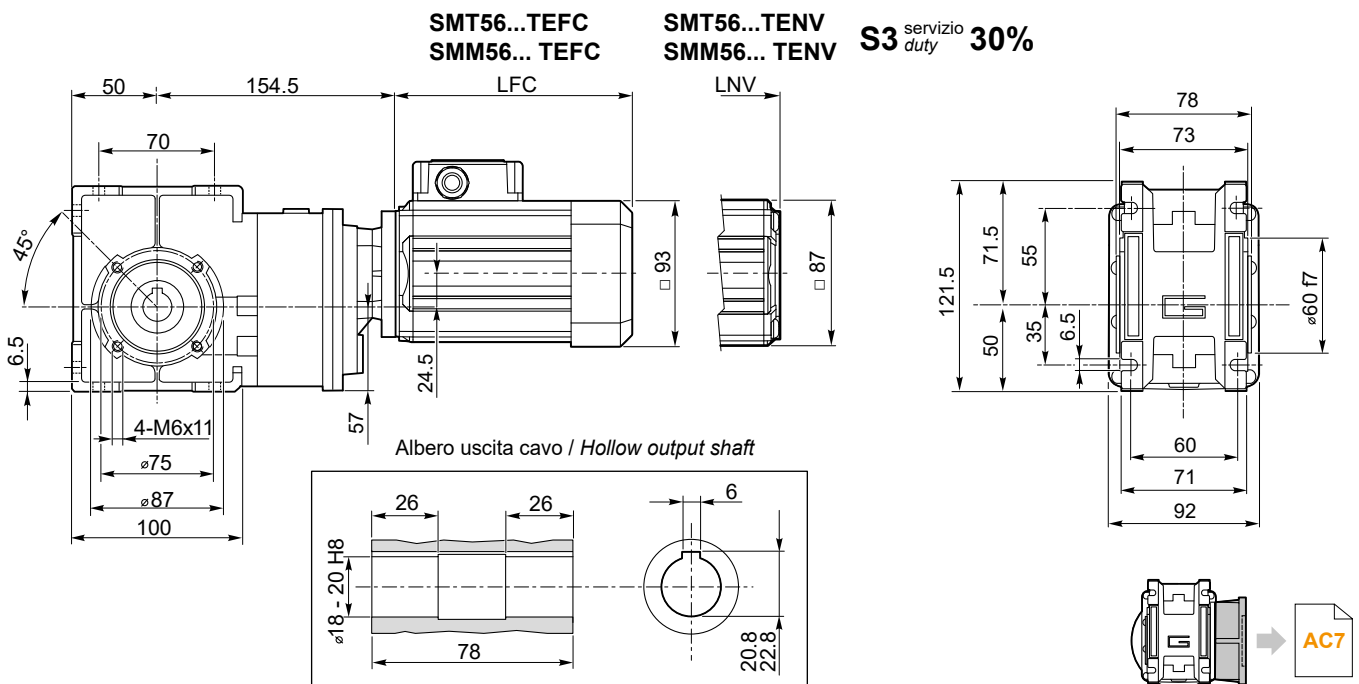

SMT	LFC	LNV	Kg	
5624	141	117	6.2	
5634	151	127	6.6	
5644	186	162	7.8	
5654	206	182	8.5	

SMM	LFC	LNV	Kg	
5624	151	127	6.5	
5634	171	147	7.1	
5644	206	182	8.4	

Nota:
il condensatore sarà fornito a corredo

Note:
the capacitor will be supplied separately

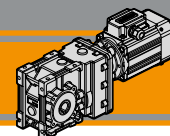

Dimensioni

Dimensions

CMB 402 U

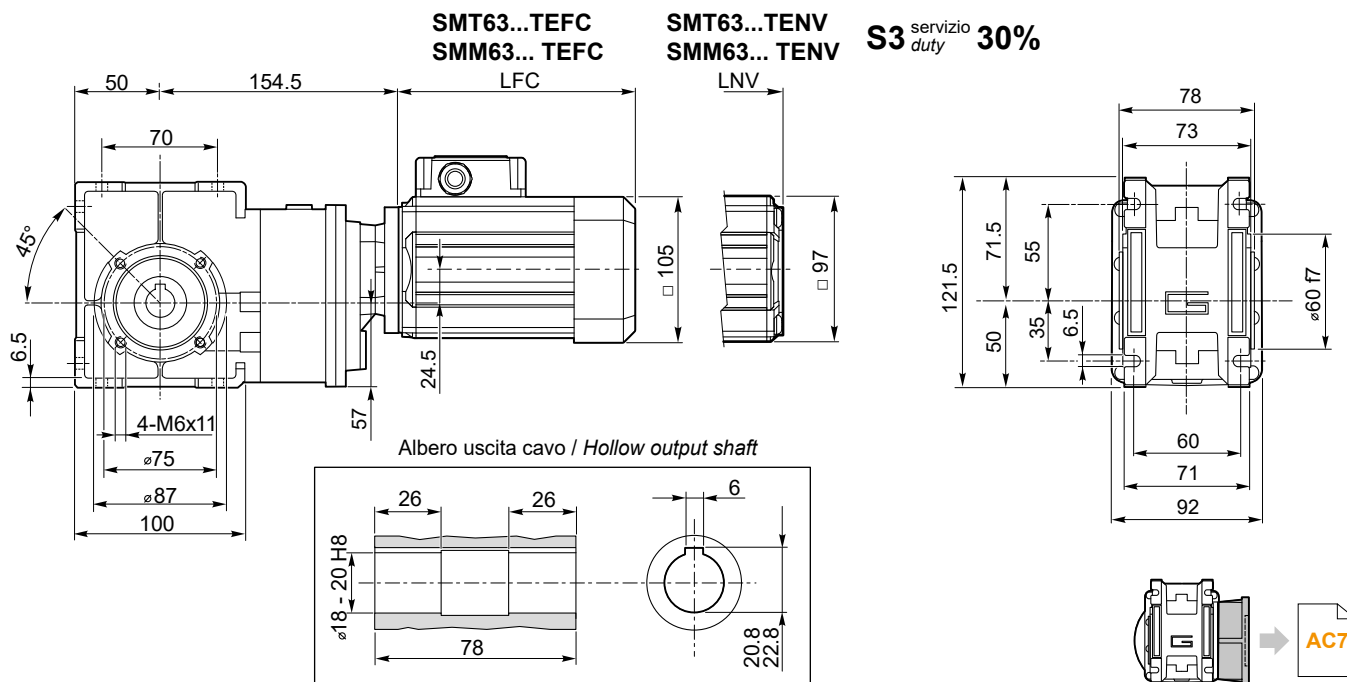

SMT	LFC	LNV	Kg	
6324	165.5	138.5	7.7	
6334	180.5	153.5	8.4	
6344	205.5	178.5	9.6	

SMM	LFC	LNV	Kg	
6324	180.5	153.5	8.5	
6334	205.5	178.5	9.7	

Nota:
il condensatore sarà fornito a corredo

Note:
the capacitor will be supplied separately

CMB402/ F... Flange uscita / Output flanges

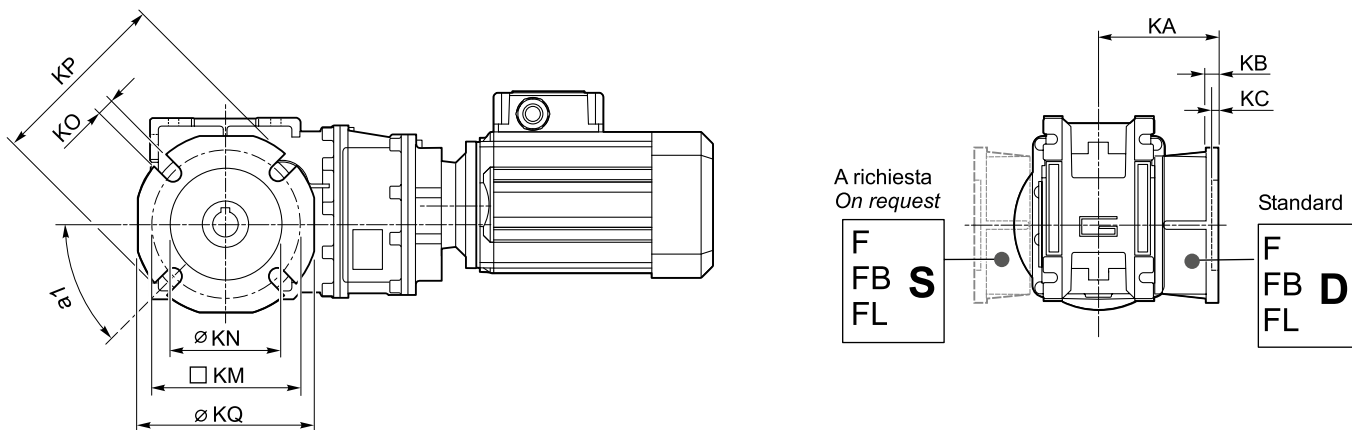

CMB	Flange uscita / Output flanges																										
	F					FL					FB																
	a ₁	KA	KB	KC	KM	KN H8	KO	KP	KQ	a ₁	KA	KB	KC	KM	KN H8	KO	KP	KQ	a ₁	KA	KB	KC	KM	KN H8	KO	KP	KQ
402	45°	67	7.5	4.5	80-95	60	9	110	95	45°	97	7.5	4.5	80-95	60	9	110	95	45°	80	8.5	5	115-125	95	9.5	140	112

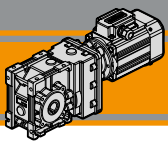

Accessori

Accessories

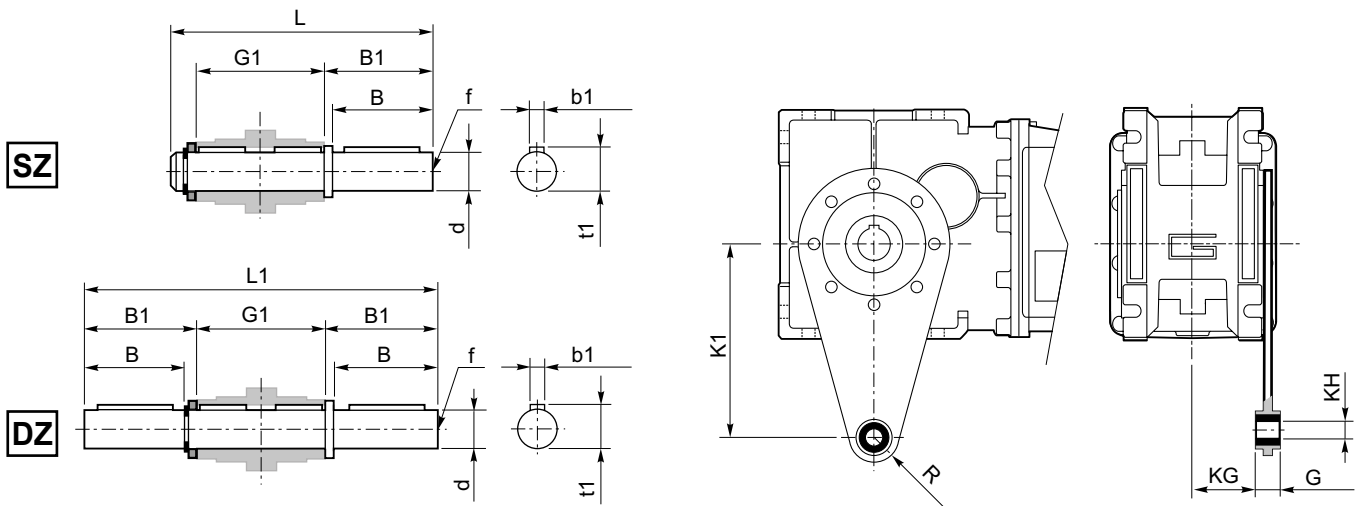

Albero lento / Output shaft

Braccio di reazione / Torque arm

CMB	d h7	B	B1	G1	L	L1	f	b1	t1
402	18	40	43	78	128	164	M6	6	20.5

CMB	K1	G	KG	KH	R
402	100	14	31	10	18

SC - Safety cover

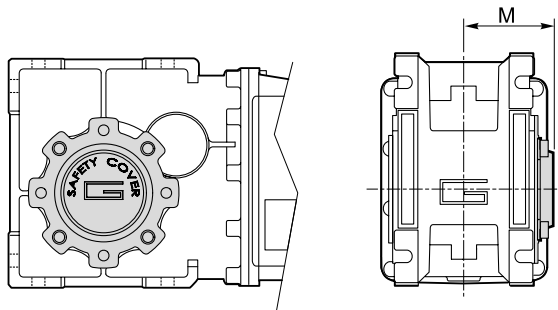

CMB	M
402	54.5

MINI 
TECNO
small but strong

KFT105 - FT

Motoriduttori CA pendolari
AC Helical parallel gearmotors

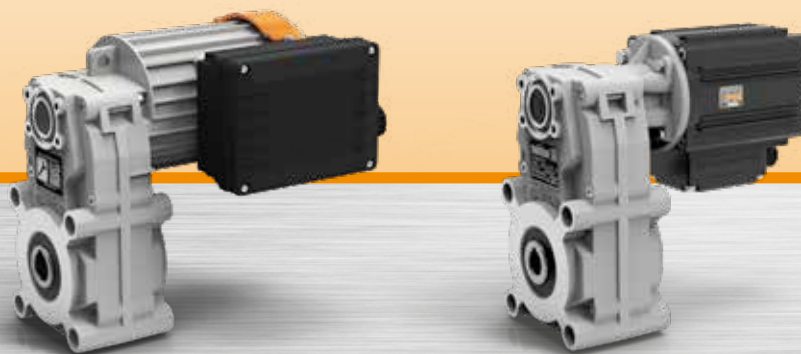

MINI 
TECNO brand of
TRANSTECNO



AC

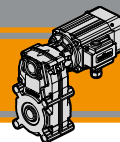

Indice	Index	Pag. Page
Caratteristiche tecniche	<i>Technical features</i>	AD2
Designazione	<i>Classification</i>	AD2
Sensi di rotazione	<i>Direction of rotation</i>	AD3
Simbologia	<i>Symbols</i>	AD3
Lubrificazione	<i>Lubrication</i>	AD3
Carichi radiali	<i>Radial loads</i>	AD4
Motori applicabili	<i>Motor adapters</i>	AD4
Dati tecnici	<i>Technical data</i>	AD5
Dati tecnici elettrici	<i>Electrical technical data</i>	AD7
Normative di riferimento	<i>Reference standards</i>	AD7
Dimensioni	<i>Dimensions</i>	AD8

Questa sezione annulla e sostituisce ogni precedente edizione o revisione. Qualora questa sezione non Vi sia giunta in distribuzione controllata, l'aggiornamento dei dati ivi contenuto non è assicurato. **In tal caso la versione più aggiornata è disponibile sul nostro sito internet www.transtecno.com**

This section replaces any previous edition and revision. If you obtained this catalogue other than through controlled distribution channels, the most up to date content is not guaranteed. In this case the latest version is available on our web site www.transtecno.com

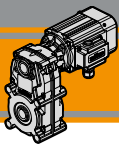

**KFT105
FT**

**Motoriduttori CA pendolari
AC Helical parallel gearmotors**



Caratteristiche tecniche

Technical features

Le caratteristiche principali dei motoriduttori KFT e FT sono:

KFT and FT gearmotor range has the following main features:

- Costruzione compatta
- Motorizzazioni in corrente alternata monofase e trifase
- Carcassa motore estrusa in alluminio anodizzato nero
- Carcasse dei riduttori in pressofusione di alluminio
- Motore elettrico AC con grado di protezione IP66
- Lubrificazione permanente con olio sintetico
- Ingranaggi sempre rettificati
- Disponibili sia nella versione ventilata TEFC (servizio S1) che non ventilata TENV (servizio S3)
- Protezioni termiche per le taglie 56 e 63
- SMT56 e SMT63 adatti al funzionamento con alimentazione da inverter

- *Compact design*
- *AC single phase and three phase motors available*
- *Motor extruded aluminum housing black anodized*
- *Gearbox die-cast aluminum housing*
- *AC electric motor in IP66 protection Standard*
- *Permanent synthetic oil long-life lubrication*
- *Ground helical gears*
- *Fan cooled TEFC (duty S1) and not ventilated TENV (duty S3) versions available*
- *Thermal protection for motor sizes 56 and 63*
- *SMT56 and SMT63 are suitable for running with inverter*

KFT105

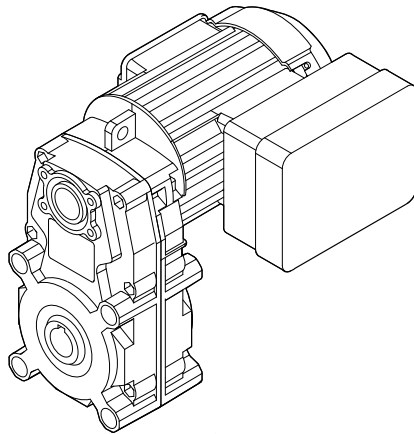

FT105

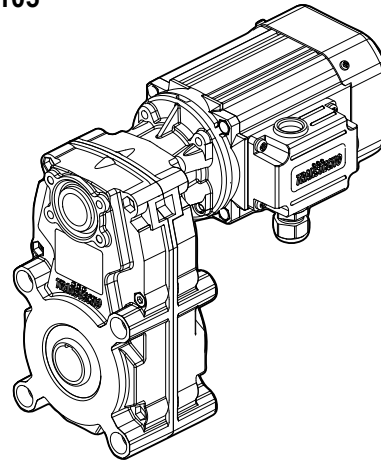

Designazione

Classification

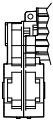
RIDUTTORE / GEARBOX				
KFT	105/3	U	88.87	O20
Tipo Type	Grandezza Size	Versione Version	Rapporto Ratio	Albero cavo uscita Hollow output shaft
KFT 	105/3 105/4	U... F...	vedi tabelle see tables	vedi tabelle see tables

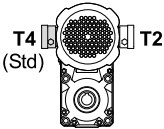
MOTORE / MOTOR						
40W	4p	3ph	230/400V	50Hz	T1	TEFC
Potenza Power	Poli Poles	Fasi Phases	Tensione Voltage	Frequenza Frequency	Pos. morsetti Terminal box pos.	Ventilazione Fan cooling
vedi tabelle see tables	2p 4p 6p	1ph 3ph	230V ... 230/400V ...	50Hz 60Hz		TEFC TENV

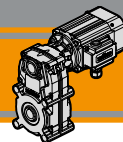
Designazione
Classification

RIDUTTORE / GEARBOX						
FT	105/3	U	77.07	O20	56	B5
Tipo Type	Grandezza Size	Versione Version	Rapporto Ratio	Albero cavo uscita Hollow output shaft	IEC 	Forma costruttiva Version
FT 	105/3 105/4	U...	vedi tabelle see tables	vedi tabelle see tables	56	B14

SMT	56	2	4	B14	230-400 V	50 Hz	TEFC	T1
Tipo Type	Grandezza Size	Indicativo potenza Power coefficient	Poli Poles	Forma costruttiva Version	Tensione Voltage	Frequenza Frequency	Ventilazione Fan cooling	Pos. morsetteria Terminal box pos.
SMT trifase threephase	vedi tabelle see tables	1-2-3-4-5	4	B14	230-400 V	50Hz 60Hz	TEFC TENV	T1 (Std)

SMM	56	2	4	B14	230 V	50 Hz	TEFC	T1
Tipo Type	Grandezza Size	Indicativo potenza Power coefficient	Poli Poles	Forma costruttiva Version	Tensione Voltage	Frequenza Frequency	Ventilazione Fan cooling	Pos. morsetteria Terminal box pos.
SMM monofase singlephase	vedi tabelle see tables	1-2-3-4	4	B14	230 V	50Hz	TEFC TENV	T1 (Std)

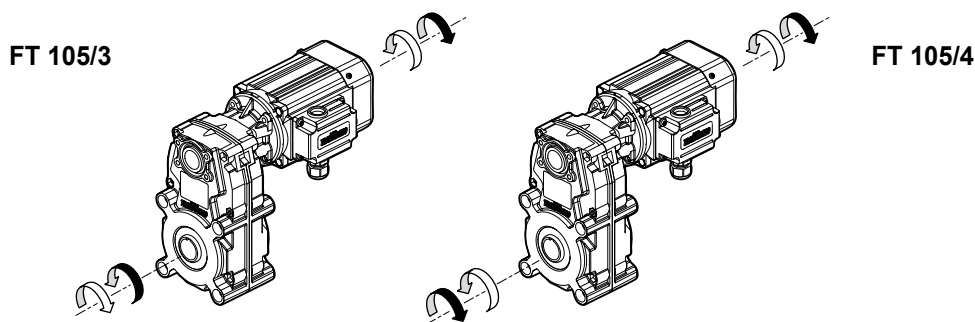
Sensi di rotazione
Direction of rotation

Simbologia
Symbols

n_1	[min^{-1}]	Velocità in ingresso / <i>Input speed</i>
n_2	[min^{-1}]	Velocità in uscita / <i>Output speed</i>
i		Rapporto di riduzione / <i>Ratio</i>
P_1	[kW]	Potenza in entrata / <i>Input power</i>
M_2	[Nm]	Coppia nominale in uscita in funzione di P_1 / <i>Output torque referred to P_1</i>
P_{n1}	[kW]	Potenza nominale in entrata / <i>Nominal input power</i>
M_{n2}	[Nm]	Coppia nominale in uscita in funzione di P_{n1} / <i>Nominal output torque referred to P_{n1}</i>
sf		Fattore di servizio / <i>Service factor</i>
R_2	[N]	Carico radiale ammissibile in uscita / <i>Permitted output radial load</i>
A_2	[N]	Carico assiale ammissibile in uscita / <i>Permitted output axial load</i>

Lubrificazione
Lubrication

Tutti i motoriduttori sono forniti completi di lubrificante sintetico viscosità 320, pertanto possono essere installati in qualunque posizione di montaggio e non necessitano di manutenzione.

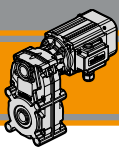
Permanent synthetic oil long-life lubrication (viscosity grade 320) makes it possible to use the gearmotors in all mounting positions; for this reason they can be installed in any assembly position and do not require maintenance.



Carichi radiali

Radial loads

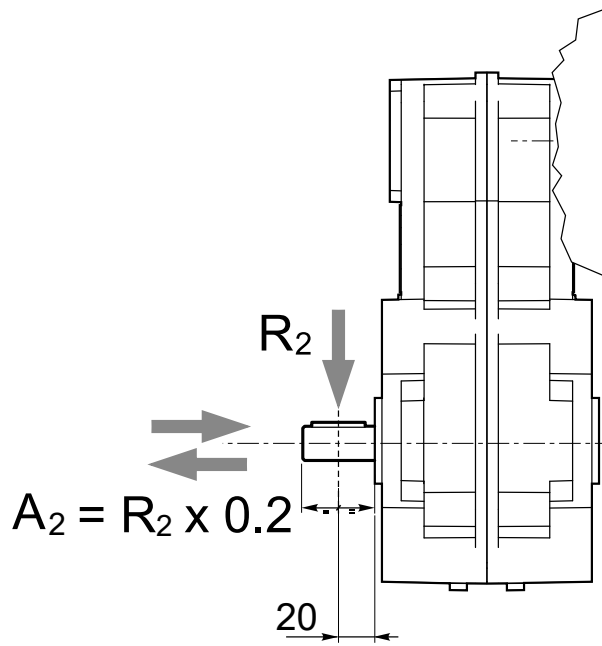

n_2 [min ⁻¹]	R_2 [N]
	KFT105 FT105
70	1500
40	1700
30	1850
20	2000
10	2000
5	2000

Quando il carico radiale risultante non è applicato sulla mezzeria dell'albero occorre calcolare quello effettivo con la seguente formula:

When the resulting radial load is not applied on the centre line of the shaft it is necessary to calculate the effective load with the following formula:

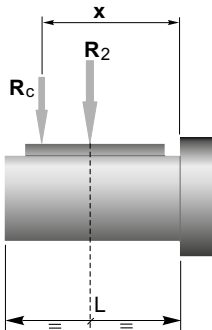

	KFT105 FT105
a	82
b	62
R_{2MAX}	2000

$$R_c = \frac{R_2 \cdot a}{(b + x)} \leq R_{2MAX}$$

a, b = valori riportati nella tabella
a, b = values given in the table

$$R \leq R_c$$

Motori applicabili

IEC Motor adapters

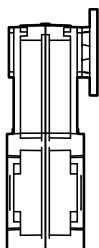
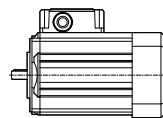

		SMT		SMM	
		5014	5624	5014	5624
		5024	5634	5024	5634
		5034	5644	5034	5644
		5044	5654		
FT	105/3	20.57 - 315.05			
FT	105/4	368.19 - 929.4			

20.57 - 929.4

Rapporti di riduzione i
Ratio i

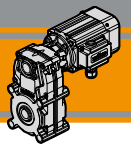

Dati tecnici

Technical data

P ₁ [kW]	n ₂ [min ⁻¹]	M ₂ [Nm]	sf	M _n [Nm]	i	
------------------------	--	------------------------	----	------------------------	---	--

P ₁ [kW]	n ₂ [min ⁻¹]	M ₂ [Nm]	sf	M _n [Nm]	i	
------------------------	--	------------------------	----	------------------------	---	--

0.025

68	3	12.1	40	20.57	KFT105/3
42	5	9.4	50	33.32	
32	7	9.1	65	44.36	
26	9	7.4	65	54.87	
19	12	5.6	65	71.84	
18	12	5.3	65	77.07	
16	14	4.6	65	88.87	
11	20	3.2	65	124.81	
7.7	29	2.2	65	181.35	
6.2	36	1.8	65	224.32	
4.4	51	1.3	65	315.05	
3.8	58	1.1	65	368.19	KFT105/4
2.6	84	0.8	65	534.98	
2.1	104	0.6	65	661.76	
1.5	120	0.5	65	929.40	

0.09

68	12	3.4	40	20.57	KFT105/3
42	19	2.6	50	33.32	
32	26	2.5	65	44.36	
26	32	2.1	65	54.87	
19	41	1.6	65	71.84	
18	44	1.5	65	77.07	
16	51	1.3	65	88.87	
11	72	0.9	65	124.81	
7.7	105	0.6	65	181.35	
6.2	110	0.6	65	224.32	

0.12

68	16	2.5	40	20.57	KFT105/3
42	26	2.0	50	33.32	
32	34	1.9	65	44.36	
26	42	1.5	65	54.87	
19	55	1.2	65	71.84	
18	59	1.1	65	77.07	
16	68	1.0	65	88.87	
11	96	0.7	65	124.81	
7.7	110	0.6	65	181.35	

0.04

68	5	7.6	40	20.57	KFT105/3
42	9	5.9	50	33.32	
32	11	5.7	65	44.36	
26	14	4.6	65	54.87	
19	18	3.5	65	71.84	
18	20	3.3	65	77.07	
16	23	2.9	65	88.87	
11	32	2.0	65	124.81	
7.7	47	1.4	65	181.35	
6.2	58	1.1	65	224.32	
4.4	81	0.8	65	315.05	
3.8	92	0.7	65	368.19	KFT105/4
2.6	120	0.5	65	534.98	
2.1	120	0.5	65	661.76	

0.06

68	8	5.1	40	20.57	KFT105/3
42	13	3.9	50	33.32	
32	17	3.8	65	44.36	
26	21	3.1	65	54.87	
19	28	2.4	65	71.84	
18	30	2.2	65	77.07	
16	34	1.9	65	88.87	
11	48	1.4	65	124.81	
7.7	70	0.9	65	181.35	
6.2	86	0.8	65	224.32	
4.4	110	0.6	65	315.05	
3.8	120	0.5	65	368.19	KFT105/4



N.B.

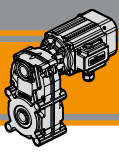

Verificare sempre che la coppia M₂ utilizzata non ecceda il valore indicato nelle caselle in grigio

N.B.

Please check that the output torque M₂ does not exceed the value in the grey areas

**FT****Motoriduttori CA pendolari**
AC Helical parallel gearmotors**Dati tecnici****Technical data**

P ₁ [kW]	n ₂ [min ⁻¹]	M ₂ [Nm]	sf	i		
0.04						
SMT5014	68	5	7.6	20.57	FT105/3	B14
SMM5014	42	9	5.9	33.32		
(1400 min ⁻¹)	32	11	5.7	44.36		
	26	14	4.6	54.87		
	19	18	3.5	71.84		
	18	20	3.3	77.07		
	16	23	2.9	88.87		
	11	32	2.0	124.81		
	7.7	47	1.4	181.35		
	6.2	58	1.1	224.32		
	4.4	81	0.8	315.05	FT105/4	B14
	3.8	92	0.7	368.19		
	2.6	120	0.5	534.98		
	2.1	120	0.5	661.76		

P ₁ [kW]	n ₂ [min ⁻¹]	M ₂ [Nm]	sf	i		
0.12						
SMT5044	68	16	2.5	20.57	FT105/3	B14
SMT5634	42	26	2.0	33.32		
SMM5624	32	34	1.9	44.36		
(1400 min ⁻¹)	26	42	1.5	54.87		
	19	55	1.2	71.84		
	18	59	1.1	77.07		
	16	68	1.0	88.87		
	11	96	0.7	124.81		
	7.7	110	0.6	181.35		

0.06						
SMT5024	68	8	5.1	20.57	FT105/3	B14
SMM5024	42	13	3.9	33.32		
(1400 min ⁻¹)	32	17	3.8	44.36		
	26	21	3.1	54.87		
	19	28	2.4	71.84		
	18	30	2.2	77.07		
	16	34	1.9	88.87		
	11	48	1.4	124.81		
	7.7	70	0.9	181.35		
	6.2	86	0.8	224.32		
	4.4	92	0.7	315.05	B14	

0.18						
SMT5644	68	24	1.7	20.57	FT105/3	B14
SMM5644	42	38	1.3	33.32		
(1400 min ⁻¹)	32	51	1.3	44.36		
	26	63	1.0	54.87		
	19	83	0.8	71.84		
	18	89	0.7	77.07		
	16	92	0.7	88.87		
	11	110	0.6	124.81		

0.09						
SMT5034	68	12	3.4	20.57	FT105/3	B14
SMM5034	42	19	2.6	33.32		
SMT5624	32	26	2.5	44.36		
SMM5624	26	32	2.1	54.87		
(1400 min ⁻¹)	19	41	1.6	71.84		
	18	44	1.5	77.07		
	16	51	1.3	88.87		
	11	72	0.9	124.81		
	7.7	105	0.6	181.35		
	6.2	110	0.6	224.32		

N.B.

Verificare sempre che la coppia M2 utilizzata non ecceda il valore indicato nelle caselle in grigio

N.B.

Please check that the output torque M2 does not exceed the value in the grey areas

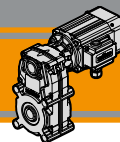
Dati tecnici elettrici
Electrical technical data

1 Ph	P _n [W]	V [V]	F [Hz]	I _n [A]	I _s [A]	cosØ	C [µF]	TEFC Servizio Duty	TENV Servizio Duty
	25	230	50	0.42	0.84	0.87	6.0	S1 100%	S3 30%
	40			0.47	0.86	0.91	6.3		
	60			0.74	1.50	0.82	8.0		
	90			0.82	1.60	0.93	12.5		
	120			1.38	3.10	0.81	14.0		

3 Ph	P _n [W]	V [V]	F [Hz]	I _n [A]	I _s [A]	cosØ	TEFC Servizio Duty	TENV Servizio Duty
	25	230	50	0.41	0.97	0.54	S1 100%	S3 30%
		400						
	40	230	50	0.43	0.97	0.62		
		400						
	60	230	50	0.72	1.80	0.48		
		400						
	90	230	50	0.74	1.80	0.60		
		400						
	120	230	50	1.34	3.70	0.50		
		400						

Nota:

Classe di rendimento Standard IE1

Note:

Standard efficiency IE1

Normative di riferimento
Reference standards

	Europe EN	World IEC	Italy CEI
Requisiti generali per macchine elettriche <i>General requirements electrical machines</i>	EN 60034-1:2010	IEC 60034-1:2010	CEI EN 60034-1:2010
Classificazione del grado di protezione <i>Classification degree of protection provided by enclosures</i>	EN 60034-5:2001	IEC 60034-5:2001	CEI EN 60034-5:2001
Sistema di raffreddamento <i>Cooling system</i>	EN 60034-6:1993	IEC 60034-6:1993	CEI EN 60034-6:1993
Modalità di montaggio <i>Mounting arrangements</i>	EN 60034-7:1993	IEC 60034-7:1993	CEI EN 60034-7:1993

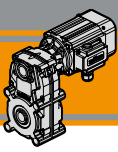

KFT 105... 25W - 40W - 60W - 90W

KFT 105...1 Ph...TEFC

KFT 105...1 Ph...TENV

S3 servizio duty 30%

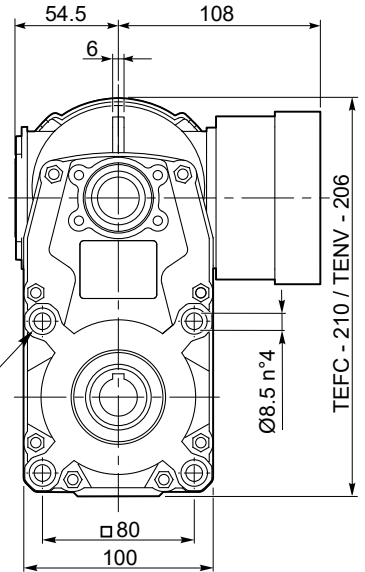
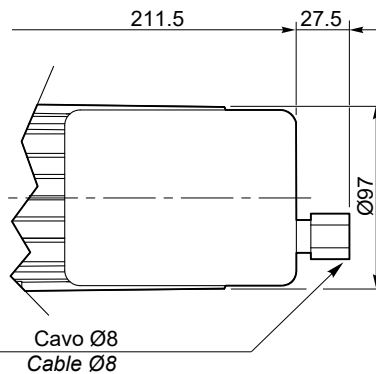
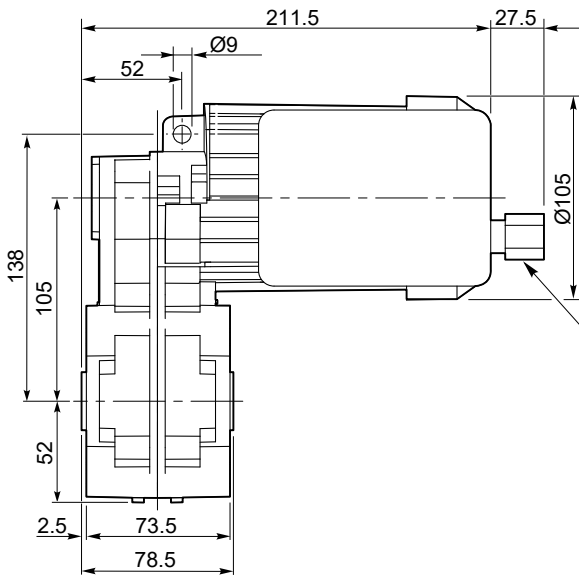

Lamature $\varnothing 14$
Prof. 10 mm n°4
Spot-facing $\varnothing 14$
Deep 10 mm n°4

NOTA: Stessi fissaggi da entrambi i lati
NOTE: Same fixing points in both sides

KFT 105...3 Ph... TEFC

KFT 105...3 Ph... TENV

S3 servizio duty 30%

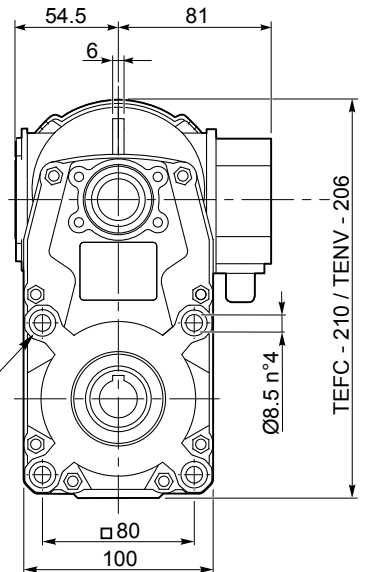
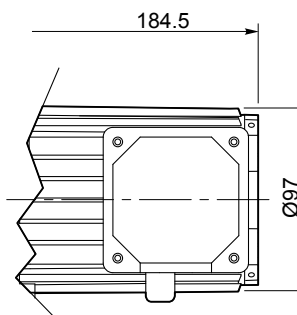
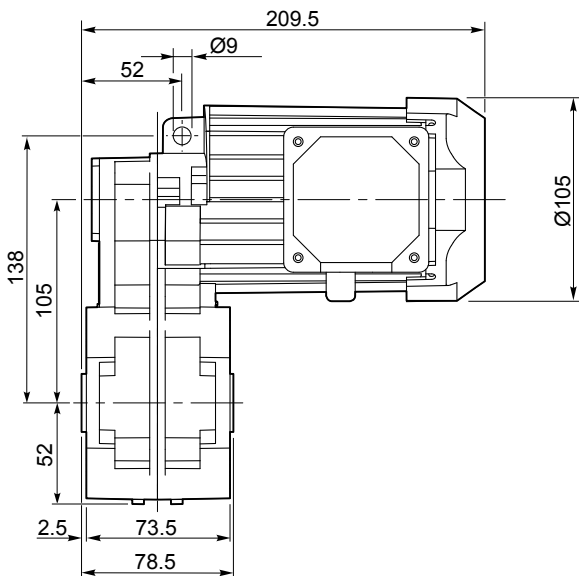

Lamature $\varnothing 14$
Prof. 10 mm n°4
Spot-facing $\varnothing 14$
Deep 10 mm n°4

NOTA: Stessi fissaggi da entrambi i lati
NOTE: Same fixing points in both sides

O17

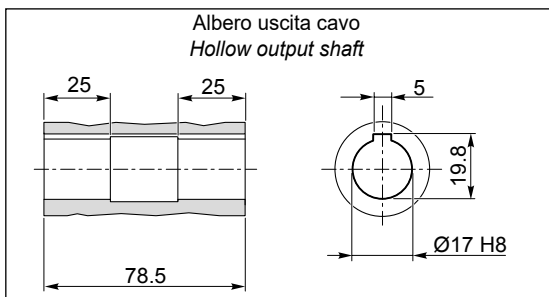

O20

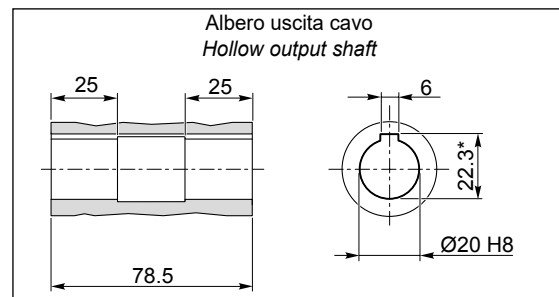

*Sede linguetta ribassata / Special Keyway

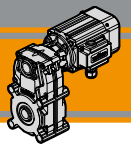

Dimensioni

Dimensions

KFT 105... 120W

KFT 105...1 Ph... TEFC

KFT 105...1 Ph...TENV S3 ^{servizio}duty 30%

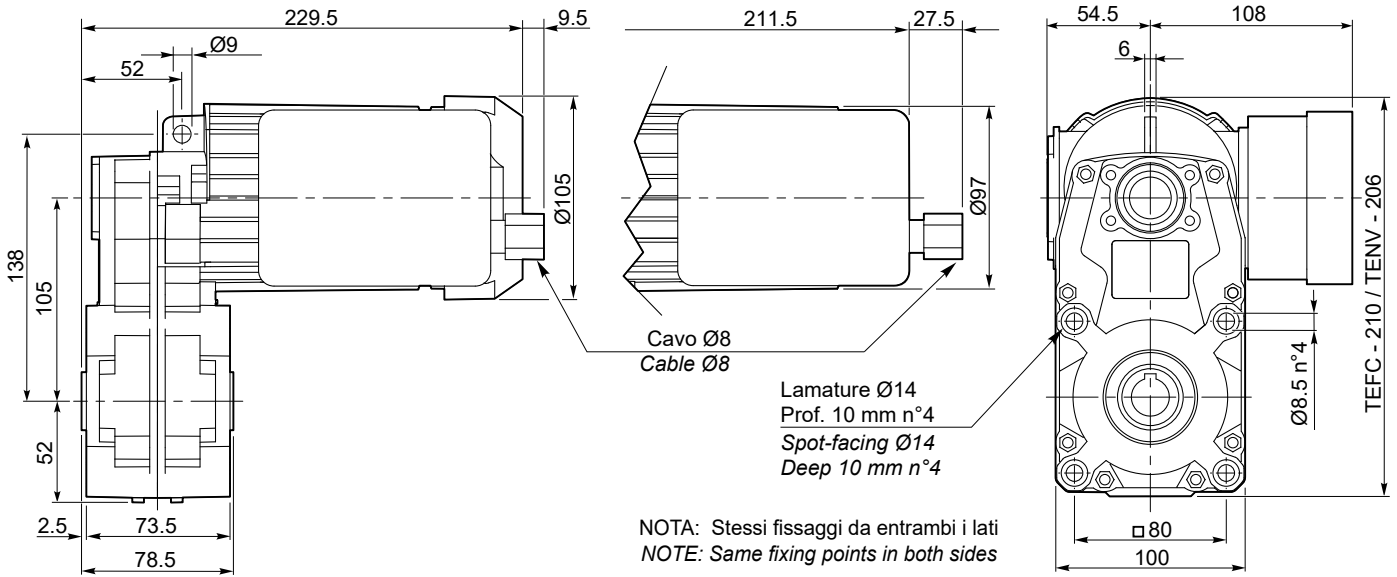

KFT 105...3 Ph... TEFC

KFT 105...3 Ph... TENV S3 ^{servizio}duty 30%

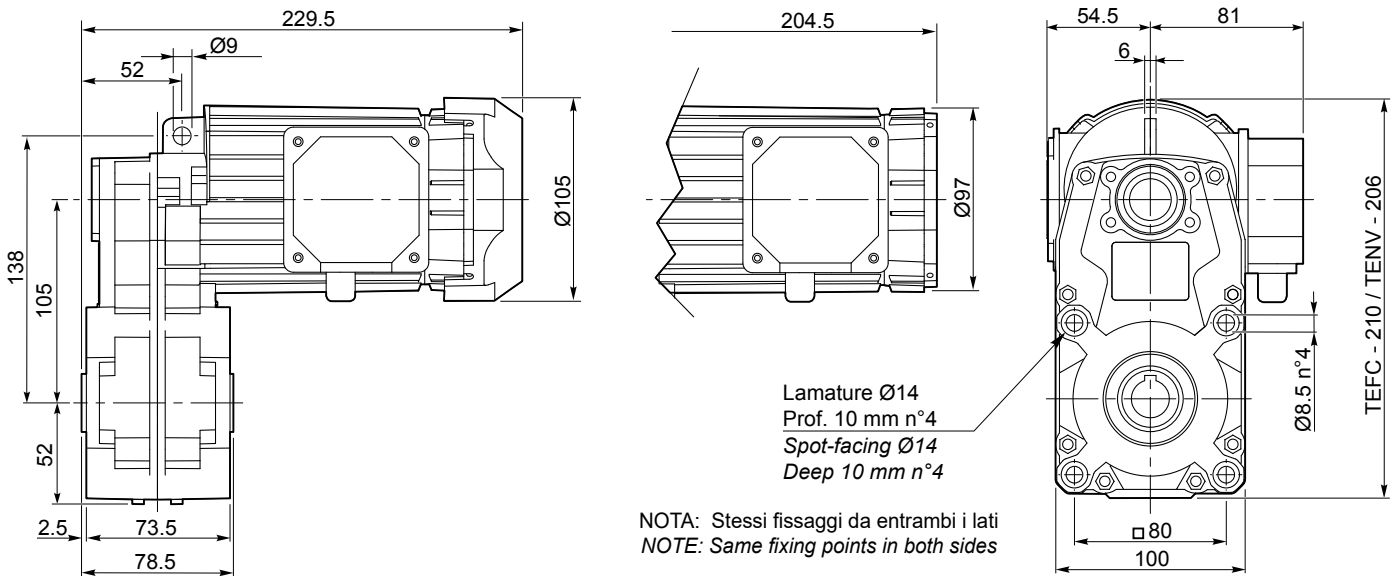

O17

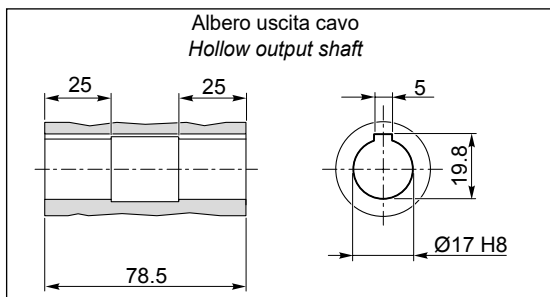

O20

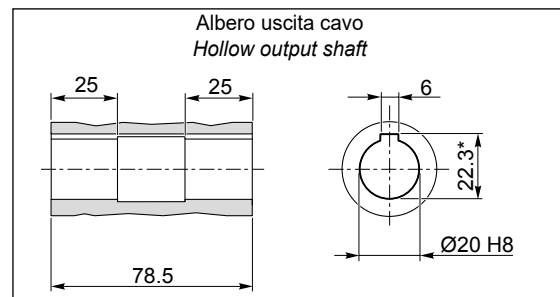

*Sede linguetta ribassata/ Special Keyway

AC

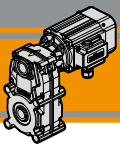

FT

Motoriduttori CA pendolari
AC Helical parallel gearmotors

MINI  **TECNO**

Dimensioni

Dimensions

FT105 U

FT 105...U

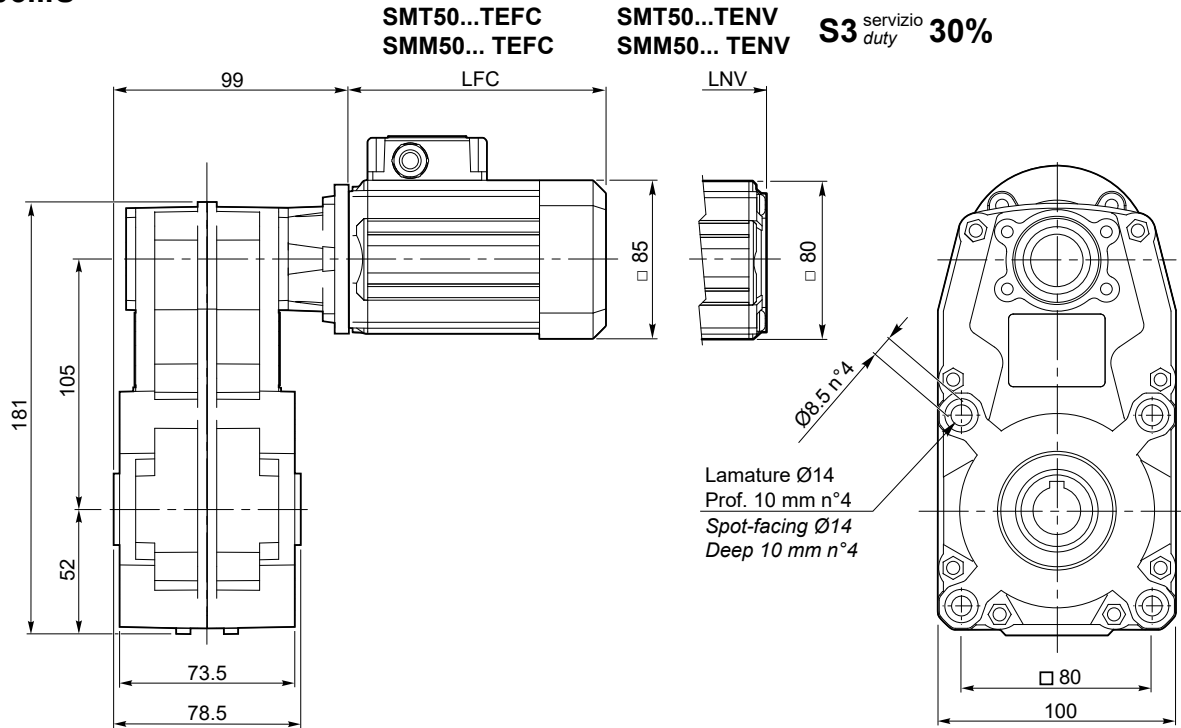

NOTA: Stessi fissaggi da entrambi i lati
NOTE: Same fixing points in both sides

SMT	LFC	LNV	Kg	
5014	135.5	108.5	6.5	
5024	150.5	123.5	6.9	
5034	175.5	148.5	7.7	
5044	200.5	173.5	8.4	

SMM	LFC	LNV	Kg	
5014	150.5	123.5	6.9	
5024	175.5	148.5	7.7	
5034	200.5	173.5	8.4	

Nota:
il condensatore sarà fornito a corredo
Note:
the capacitor will be supplied separately

O17

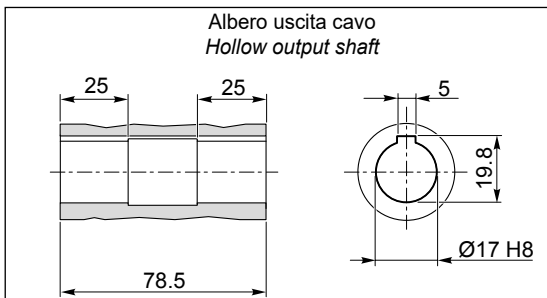

O20

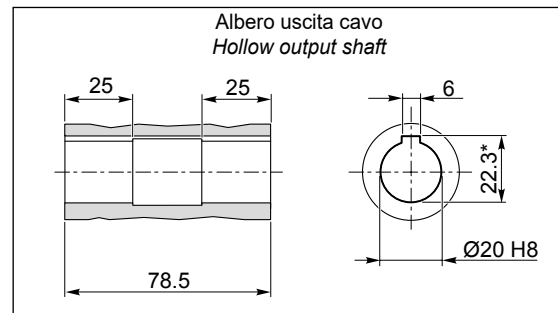

*: Sede linguetta ribassata / Special keyway

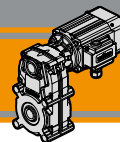

Dimensioni

Dimensions

FT105 U

FT 105...U

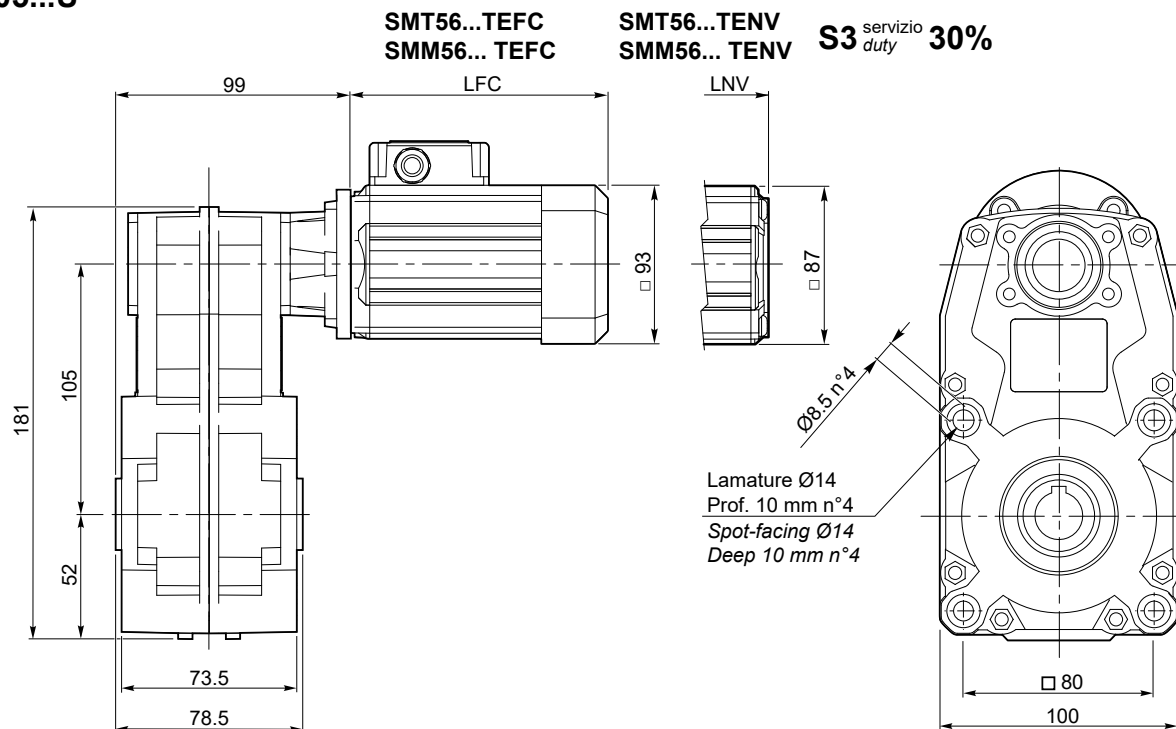

S3 servizio duty 30%

NOTA: Stessi fissaggi da entrambi i lati
NOTE: Same fixing points in both sides

SMT	LFC	LNV	Kg	
5624	141	117	7	
5634	151	127	7.4	
5644	186	162	8.6	
5654	206	182	9.3	

SMM	LFC	LNV	Kg	
5624	151	127	7.3	
5634	171	147	7.9	
5644	206	182	9.2	

Nota:
il condensatore sarà fornito a corredo
Note:
the capacitor will be supplied separately

O17

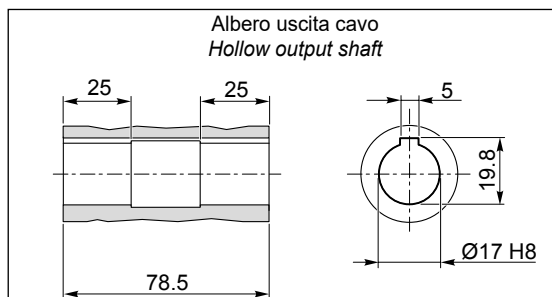

O20

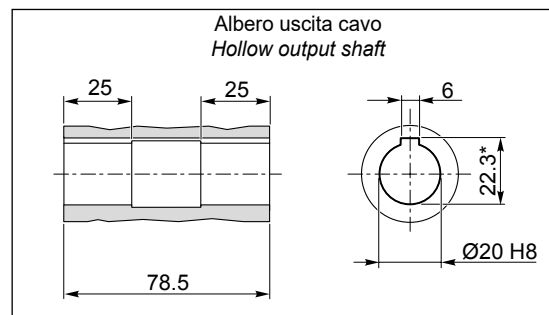

*: Sede linguetta ribassata / Special keyway

MINI 
TECNO
small but strong

CM-CMP

Motoriduttori CA a vite senza fine
AC Wormgearmotors

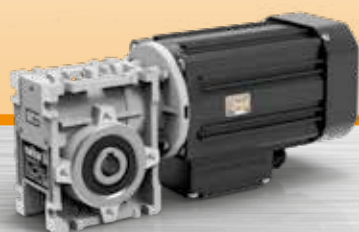

MINI 
TECNO brand of
TRANSTECNO[®]



AC

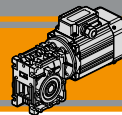

Indice	Index	Pag. Page
Caratteristiche tecniche	<i>Technical features</i>	AE2
Designazione	<i>Classification</i>	AE2
Sensi di rotazione	<i>Direction of rotation</i>	AE3
Simbologia	<i>Symbols</i>	AE4
Lubrificazione	<i>Lubrication</i>	AE4
Carichi radiali	<i>Radial loads</i>	AE4
Dati di dentatura	<i>Toothing data</i>	AE5
Rendimento	<i>Efficiency</i>	AE5
Motori applicabili	<i>Motor adapters</i>	AE5
Dati tecnici	<i>Technical</i>	AE6
Dimensioni	<i>Dimensions</i>	AE8
Opzioni	<i>Options</i>	AE17
Accessori	<i>Accessories</i>	AE17

Questa sezione annulla e sostituisce ogni precedente edizione o revisione. Qualora questa sezione non Vi sia giunta in distribuzione controllata, l'aggiornamento dei dati ivi contenuto non è assicurato. **In tal caso la versione più aggiornata è disponibile sul nostro sito internet www.transtecno.com**

This section replaces any previous edition and revision. If you obtained this catalogue other than through controlled distribution channels, the most up to date content is not guaranteed. In this case the latest version is available on our web site www.transtecno.com

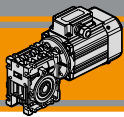
**CM
CMP**

Motoriduttori CA a vite senza fine AC Wormgearmotors



Caratteristiche tecniche

Technical features

Le caratteristiche principali dei motoriduttori CM e CMP sono:

CM and CMP gearmotors range has the following main features:

- Costruzione compatta
- Motorizzazioni in corrente alternata monofase e trifase
- Carcassa motore estrusa in alluminio anodizzato nero
- Carcasse dei riduttori in pressofusione di alluminio
- Motore elettrico AC con grado di protezione IP66
- Lubrificazione permanente con olio sintetico
- Disponibili sia nella versione ventilata TEFC (servizio S1) che non ventilata TENV (servizio S3)
- Protezioni termiche per le taglie 56 e 63
- SMT56 e SMT63 adatti al funzionamento con alimentazione da inverter

- Compact design
- AC single phase and three phase motors available
- Motor extruded aluminum housing black anodized
- Gearbox die-cast aluminum housing
- AC electric motor in IP66 protection Standard
- Permanent synthetic oil long-life lubrication
- Fan cooled TEFC (duty S1) and not ventilated TENV (duty S3) versions available
- Thermal protection for motor sizes 56 and 63
- SMT56 and SMT63 are suitable for running with inverter

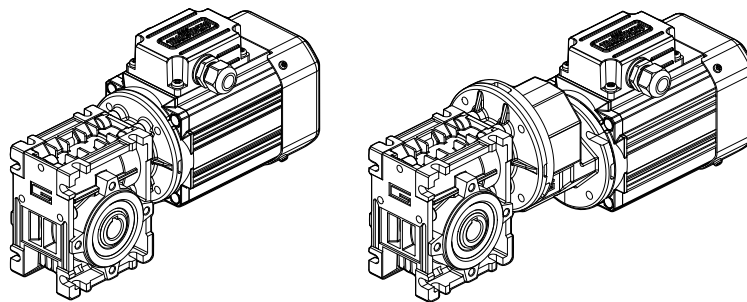

Designazione

Classification

RIDUTTORI A VITE SENZA FINE / WORMGEARBOXES

RIDUTTORE / GEARBOX									
CM	040	U	10	63	B14	SZDX	BR SX	90	VS
Tipo Type	Grandezza Size	Versione riduttore Gearbox Version	Rapporto Ratio	IEC 	Forma costruttiva Version	Albero di uscita Output shaft	Braccio di reazione Torque arm	Angolo Angle	Opzioni Options
 CM	026 026 (D11) 026 (D14) 030 040	U F...	Vedere tabella See tables	56.. 63..	B14	SZDX SZSX DZ	BRDX BR SX *	0° 90° 180° 270°	VS

RIDUTTORI A VITE SENZA FINE CON PRECOPPIA / PRE-STAGE WORMGEARBOXES

RIDUTTORE / GEARBOX										
CMP	063/040	U	90	63	B14	SZDX	BR SX	90	P4	VS
Tipo Type	Grandezza Size	Versione Riduttore Gearbox Version	Rapporto Ratio	IEC 	Forma costruttiva Version	Albero di uscita Output shaft	Braccio di reazione Torque arm	Angolo Angle	Pos. di montaggio precoppia Pre stage mounting position	Opzioni Options
 CMP	056/030 056/040 063/040	U F...	Vedere tabella See tables	56.. 63..	B5 B14	SZDX SZSX DZ	BRDX BR SX *	0° 90° 180° 270°	P1 P2 P3 (standard) P4	VS

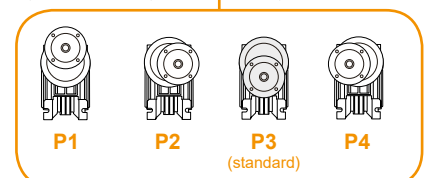

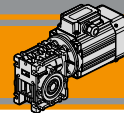

Designazione

Classification

<p>Versione Riduttore Gearbox Version</p> <p>U F...D F...S</p>	<p>Albero di uscita Output shaft</p> <p>SZDX SZSX DZ</p>	<p>Braccio di reazione * Torque arm</p> <p>BRDX BRSX</p>	<p>Angolo Angle</p>
---	---	--	-------------------------

* NOTA: il braccio di reazione viene fornito smontato.
NOTE: the torque arm will be supplied not assembled.

SMT	63	2	4	B14	230-400 V	50 Hz	TEFC	T1
Tipo Type	Grandezza Size	Indicativo potenza Power coefficient	Poli Poles	Forma costruttiva Version	Tensione Voltage	Frequenza Frequency	Ventilazione Fan cooling	Pos. morsetteria Terminal box pos.
SMT trifase threephase	vedi tabelle see tables	1-2-3-4-5	4	B14	230-400 V	50Hz 60Hz	TEFC TENV	 T1 (Std) T4 T2 T3
SMM	63	2	4	B14	230 V	50 Hz	TEFC	T1
Tipo Type	Grandezza Size	Indicativo potenza Power coefficient	Poli Poles	Forma costruttiva Version	Tensione Voltage	Frequenza Frequency	Ventilazione Fan cooling	Pos. morsetteria Terminal box pos.
SMM monofase singlephase	vedi tabelle see tables	1-2-3-4	4	B14	230 V	50Hz	TEFC TENV	 T1 (Std) T4 T2 T3

Sensi di rotazione

Direction of rotation

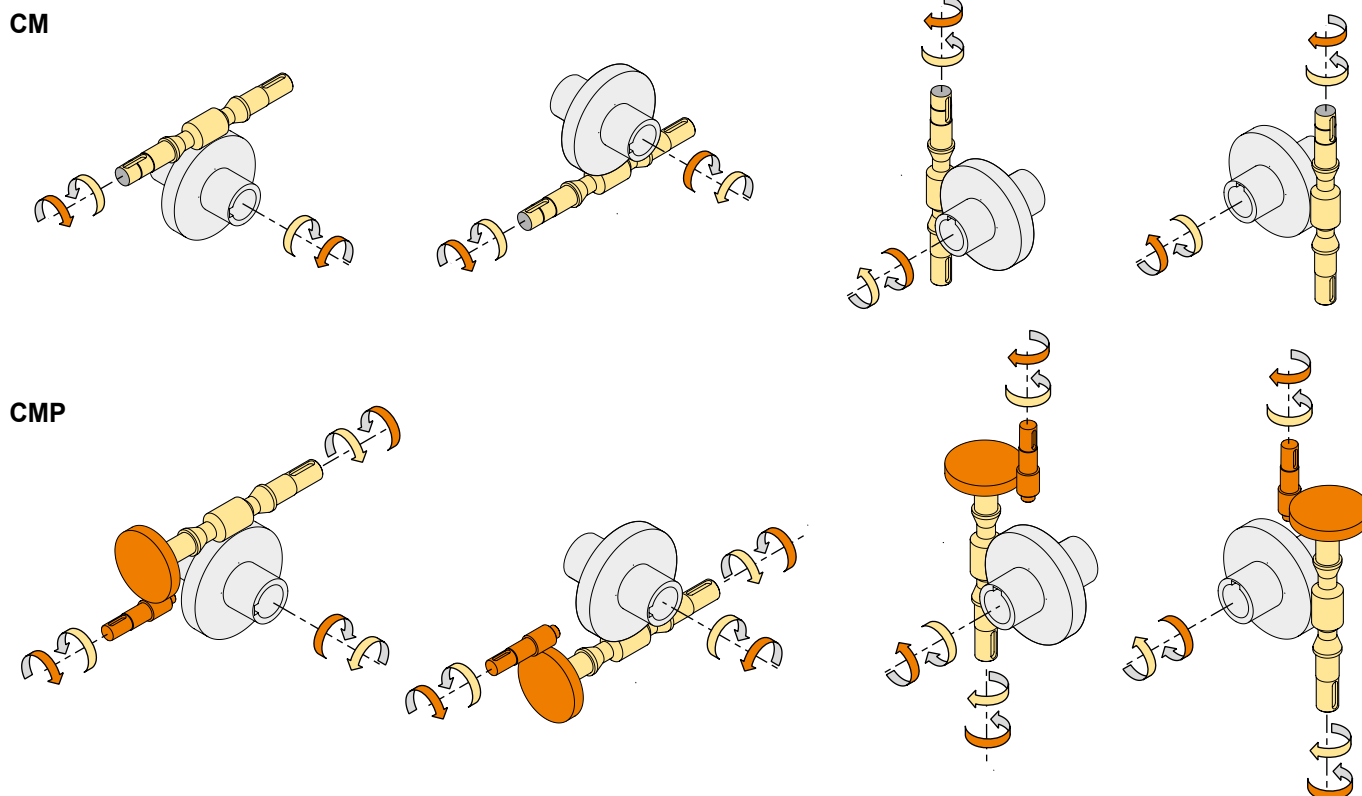

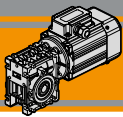
**CM
CMP****Simbologia****Symbols**

n_1 [min ⁻¹]	Velocità in ingresso / <i>Input speed</i>	R_d %	Rendimento dinamico / <i>Dynamic efficiency</i>
n_2 [min ⁻¹]	Velocità in uscita / <i>Output speed</i>	A_2 [N]	Carico assiale ammissibile in uscita / <i>Permitted output axial load</i>
i	Rapporto di riduzione / <i>Ratio</i>	R_s %	Rendimento statico / <i>Static efficiency</i>
P_1 [kW]	Potenza in entrata / <i>Input power</i>	R_2 [N]	Carico radiale ammissibile in uscita / <i>Permitted output radial load</i>
M_2 [Nm]	Coppia in uscita in funzione di P_1 / <i>Output torque referred to P_1</i>	Z	Numero di principi della vite / <i>Worm starts</i>
sf	Fattore di servizio / <i>Service factor</i>	β	Angolo d'elica / <i>Helix angle</i>

Lubrificazione**Lubrication**

I riduttori a vite senza fine della serie CM sono lubrificati a vita con olio sintetico di viscosità 320 e possono essere installati in qualunque posizione di montaggio.

Permanent synthetic oil long-life lubrication allow to use CM wormgearbox range in all mounting position.

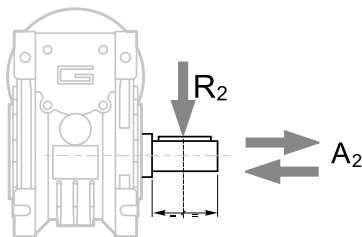
Carichi radiali**Radial loads**

$$A_2 = R_2 \times 0.2$$

n_2 [min ⁻¹]	R_2 [N]		
	CM026	CM030	CM040
187	400	674	1264
140	490	743	1392
93	580	851	1596
70	610	936	1754
56	610	1008	1890
47	610	1069	2004
35	610	1179	2210
28	610	1270	2381
23	610	1356	2542
18	610	1471	2759
14	610	1600	3000
		CMP... /030	CMP... /040

Quando il carico radiale risultante non è applicato sulla mezza-ria dell'albero occorre calcolare quello effettivo con la seguente formula:

When the resulting radial load is not applied on the centre line of the shaft it is necessary to calculate the effective load with the following formula:

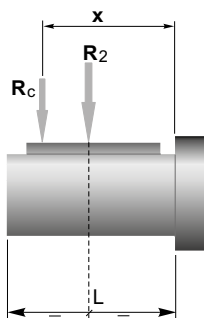

$$R_c = \frac{R_2 \cdot a}{(b + x)} \leq R_{2MAX}$$

$$R \leq R_c$$

*a, b = valori riportati nella tabella
a, b = values given in the table*

	CM	CM / CMP	
	026	030	040
a	56	65	84
b	43	50	64
R_{2MAX}	610	1600	3000

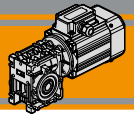

Dati di dentatura

Toothing data

	Dati della coppia vite-corona Worm wheel data	Rapporto / Ratio											
		5	7.5	10	15	20	25	30	40	50	60	80	100
CM026	Z	6	4	3	2	2		1	1	1	1		
	β	34° 35'	24° 41'	19° 1'	12° 57'	10° 30'		6° 33'	5° 17'	4° 26'	3° 49'		
CM030	Z	6	4	3	2	2	2	1	1	1	1	1	1
	β	27° 4'	24° 28'	18° 50'	12° 49'	10° 23'	8° 43'	6° 29'	5° 14'	4° 23'	3° 46'	2° 57'	2° 25'
CM040	Z	6	4	3	2	2	2	1	1	1	1	1	1
	β	34° 19'	24° 28'	18° 50'	12° 49'	10° 23'	8° 43'	6° 29'	5° 14'	4° 23'	3° 46'	2° 57'	2° 25'

Rendimento

Efficiency

	n_1 [min ⁻¹]	Rendimento Efficiency	Rapporto / Ratio											
			5	7.5	10	15	20	25	30	40	50	60	80	100
CM026	2800	Rd	89	87	85	83	80		73	68	64	60		
	1400		87	84	83	78	74		66	61	57	53		
	900		84	83	80	75	71		61	57	52	48		
			Rs	72	71	68	61	56		46	41	36	34	
CM030	2800	Rd	89	88	86	84	81	78	74	70	65	62	57	52
	1400		86	85	84	79	75	72	67	62	58	55	48	43
	900		84	83	81	75	71	68	62	58	53	49	43	39
			Rs	72	67	63	55	50	43	39	35	31	27	23
CM040	2800	Rd	90	89	87	84	83	80	77	73	69	66	60	56
	1400		88	86	84	81	78	74	70	65	60	58	52	46
	900		86	84	82	77	74	70	66	60	57	53	46	41
			Rs	74	71	67	60	55	51	45	40	36	32	28



Rendimento teorico del riduttore dopo il rodaggio
Theoretical efficiency of the gearbox after the first running period

Motori applicabili

Motor adapters

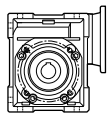
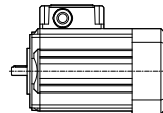

		SMT			SMM		
		5014 5024 5034 5044	5624 5634 5644 5654	6324 6334 6344	5014 5024 5034	5624 5634 5644	6324 6334
CM	026	5 - 60				5 - 60	
	030	5 - 100		5-50	5 - 100		5-50
	040	5- 100					

5 - 100

Rapporti di riduzione i
Ratio i

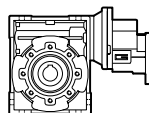

		SMT			SMM		
		5014 5024 5034 5044	5624 5634 5644 5654	6324 6334 6344	5014 5024 5034	5624 5634 5644	6324 6334
CMP	056/030	60 - 150				60 - 150	
	056/040	60 - 300			60 - 300		
	063/040			60 - 120			60 - 120

60 - 300

Rapporti di riduzione i
Ratio i

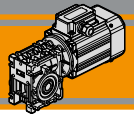

Dati tecnici

Technical data

P_1 [kW]	n_2 [min ⁻¹]	M_2 [Nm]	sf	i				P_1 [kW]	n_2 [min ⁻¹]	M_2 [Nm]	sf	i			
0.12								0.18							
SMT5044	280	3.5	5.1	5	CM030		B14	SMT6324	140	10	4.4	10	CM040		B14
SMT5634	187	5.2	3.8	7.5	CM030		B14	SMM6324	93	15	3.0	15	CM040		B14
SMM5634	140	6.9	3.1	10	CM030		B14	(1400 min ⁻¹)	70	19	2.1	20	CM040		B14
	93	10	2.2	15	CM030		B14		56	23	1.7	25	CM040		B14
	70	12	1.5	20	CM030		B14		47	26	1.9	30	CM040		B14
	56	15	1.4	25	CM030		B14		35	32	1.3	40	CM040		B14
	47	16	1.3	30	CM030		B14		28	37	1.1	50	CM040		B14
	35	20	1.0	40	CM030		B14		23	43	0.8	60	CM040		B14
	28	24	0.8	50	CM030		B14		23	51	1.1	60	CM040	CMP063/040	B14
	23	32	0.8	60	CM030	CMP056/030	B14		19	60	0.9	75	CM040	CMP063/040	B14
									18	68	1.0	90	CM040	CMP063/040	B14
	93	10	4.5	15	CM040		B14	0.25							
	70	13	3.1	20	CM040		B14	SMT5654	280	7	1.8	5	CM026		B14
	56	15	2.5	25	CM040		B14	(1400 min ⁻¹)	187	11	1.3	8	CM026		B14
	47	17	2.8	30	CM040		B14		140	14	1.0	10	CM026		B14
	35	21	2.0	40	CM040		B14								
	28	25	1.6	50	CM040		B14		280	7.3	2.5	5	CM030		B14
	23	28	1.3	60	CM040		B14		187	11	1.8	7.5	CM030		B14
	23	34	1.7	60	CM040	CMP056/040	B14		140	14	1.5	10	CM030		B14
	19	40	1.3	75	CM040	CMP056/040	B14		93	20	1.0	15	CM030		B14
	18	34	1.0	80	CM040	CMP056/040	B14		70	26	0.7	20	CM030		B14
	16	45	1.6	90	CM040	CMP056/040	B14								
	14	38	0.8	100	CM040	CMP056/040	B14		280	7.5	5.5	5	CM040		B14
	12	56	1.1	120	CM040	CMP056/040	B14		187	11	4.0	7.5	CM040		B14
	9	64	1.0	150	CM040	CMP056/040	B14		140	14	3.1	10	CM040		B14
0.18									93	21	2.2	15	CM040		B14
SMT5644	280	5.3	2.4	5	CM026		B14		70	27	1.5	20	CM040		B14
SMM5644	187	7.7	1.8	7.5	CM026		B14		56	32	1.2	25	CM040		B14
(1400 min ⁻¹)	140	10	1.4	10	CM026		B14		47	36	1.3	30	CM040		B14
	93	14	1.0	15	CM026		B14		35	44	0.9	40	CM040		B14
	70	18	0.8	20	CM026		B14		28	51	0.8	50	CM040		B14
									23	70	0.8	60	CM040	CMP056/040	B14
	280	5.3	3.4	5	CM030		B14	0.25							
	187	7.8	2.6	7.5	CM030		B14	SMT6334	280	7.3	2.5	5	CM030		B14
	140	10	2.0	10	CM030		B14	(1400 min ⁻¹)	187	11	1.8	7.5	CM030		B14
	93	15	1.4	15	CM030		B14		140	14	1.5	10	CM030		B14
	70	18	1.0	20	CM030		B14		93	20	1.0	15	CM030		B14
	56	22	0.9	25	CM030		B14		70	26	0.7	20	CM030		B14
	47	25	0.9	30	CM030		B14								
	280	5.4	7.6	5	CM040		B14		280	7.5	5.5	5	CM040		B14
	187	7.9	5.6	7.5	CM040		B14		187	11	4.0	7.5	CM040		B14
	140	10	4.4	10	CM040		B14		140	14	3.1	10	CM040		B14
	93	15	3.0	15	CM040		B14		93	21	2.2	15	CM040		B14
	70	19	2.1	20	CM040		B14		70	27	1.5	20	CM040		B14
	56	23	1.7	25	CM040		B14		56	32	1.2	25	CM040		B14
	47	26	1.9	30	CM040		B14		47	36	1.3	30	CM040		B14
	35	32	1.3	40	CM040		B14		35	44	0.9	40	CM040		B14
	28	37	1.1	50	CM040		B14		28	51	0.8	50	CM040		B14
	23	43	0.8	60	CM040		B14		23	70	0.8	60	CM040	CMP063/040	B14
	23	51	1.1	60	CM040	CMP056/040	B14								
	19	60	0.9	75	CM040	CMP056/040	B14	0.37							
	18	68	1.0	90	CM040	CMP056/040	B14	SMT6334	280	11	1.7	5	CM030		B14
0.18								(1400 min ⁻¹)	187	16	1.2	7.5	CM030		B14
SMT6324	280	5.3	3.4	5	CM030		B14		140	21	1.0	10	CM030		B14
SMM6324	187	7.8	2.6	7.5	CM030		B14		93	30	0.7	15	CM030		B14
(1400 min ⁻¹)	140	10	2.0	10	CM030		B14								
	93	15	1.4	15	CM030		B14		280	11	3.7	5	CM040		B14
	70	18	1.0	20	CM030		B14		187	16	2.7	7.5	CM040		B14
	56	22	0.9	25	CM030		B14		140	21	2.1	10	CM040		B14
	47	25	0.9	30	CM030		B14		93	31	1.5	15	CM040		B14
									70	39	1.0	20	CM040		B14
	280	5.4	7.6	5	CM040		B14		56	47	0.8	25	CM040		B14
	187	7.9	5.6	7.5	CM040		B14		47	53	0.9	30	CM040		B14

AC

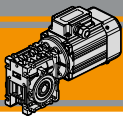

CM
CMP

Dimensioni

Dimensions

CM 026 .. U

SMT50...TEFC
SMM50... TEFC

SMT50...TENV
SMM50... TENV

S3 servizio 30%
duty

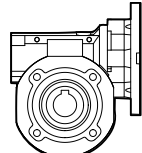
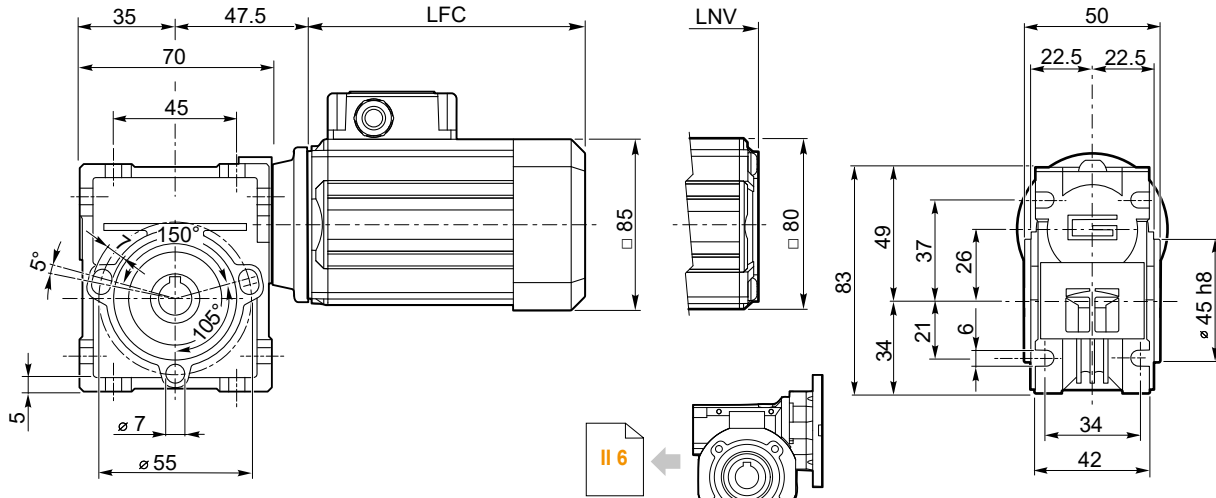

CL026

Albero lento cavo / Hollow output shaft

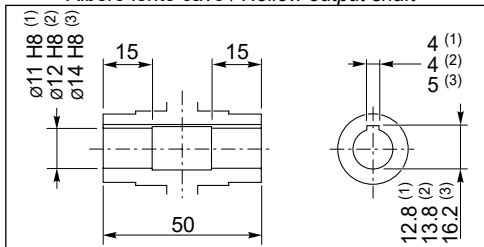

SMT	LFC	LNV	Kg	
5014	135.5	108.5	3.1	
5024	150.5	123.5	3.5	
5034	175.5	148.5	4.3	
5044	200.5	173.5	5	

SMM	LFC	LNV	Kg	
5014	150.5	123.5	3.5	
5024	175.5	148.5	4.3	
5034	200.5	173.5	5	

Nota: il condensatore sarà fornito a corredo
Note: the capacitor will be supplied separately

- (1): CM 120/026 (D11)
- (2): CM 120/026
- (3): CM 120/026 (D14)

CM 026 .. U

SMT56...TEFC
SMM56... TEFC

SMT56...TENV
SMM56... TENV

S3 servizio 30%
duty

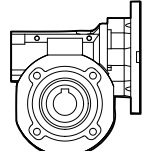
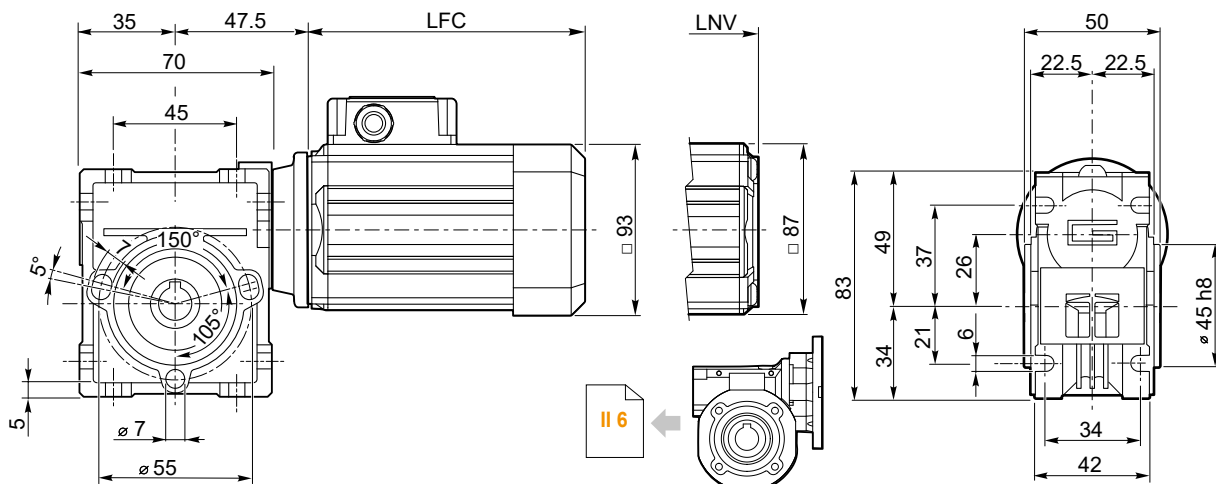

CL026

Albero lento cavo / Hollow output shaft

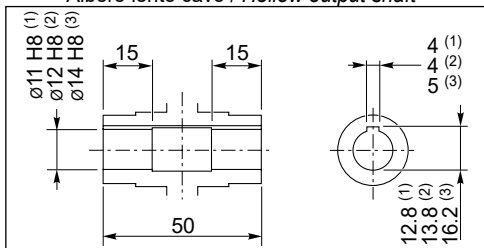

SMT	LFC	LNV	Kg	
5624	141	117	3.6	
5634	151	127	4	
5644	186	162	5.2	
5654	206	182	5.9	

SMM	LFC	LNV	Kg	
5624	151	127	3.9	
5634	171	147	4.5	
5644	206	182	5.8	

Nota: il condensatore sarà fornito a corredo
Note: the capacitor will be supplied separately

- (1): CM 120/026 (D11)
- (2): CM 120/026
- (3): CM 120/026 (D14)

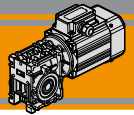

Dimensioni

Dimensions

CM 026 .. F

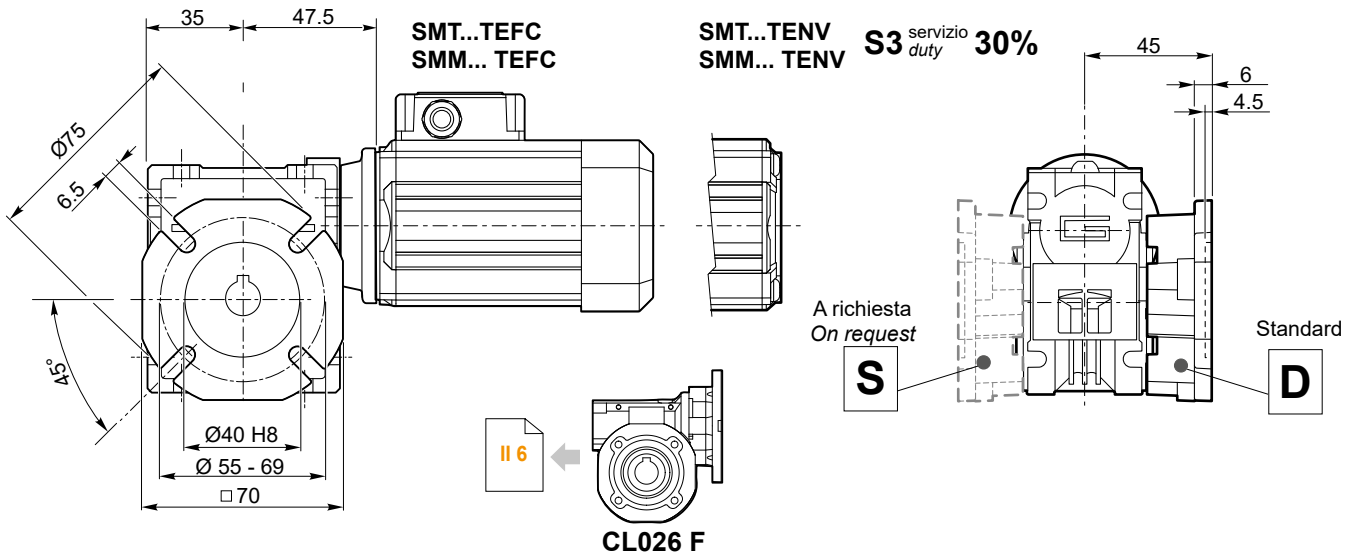

CM 026 .. F28

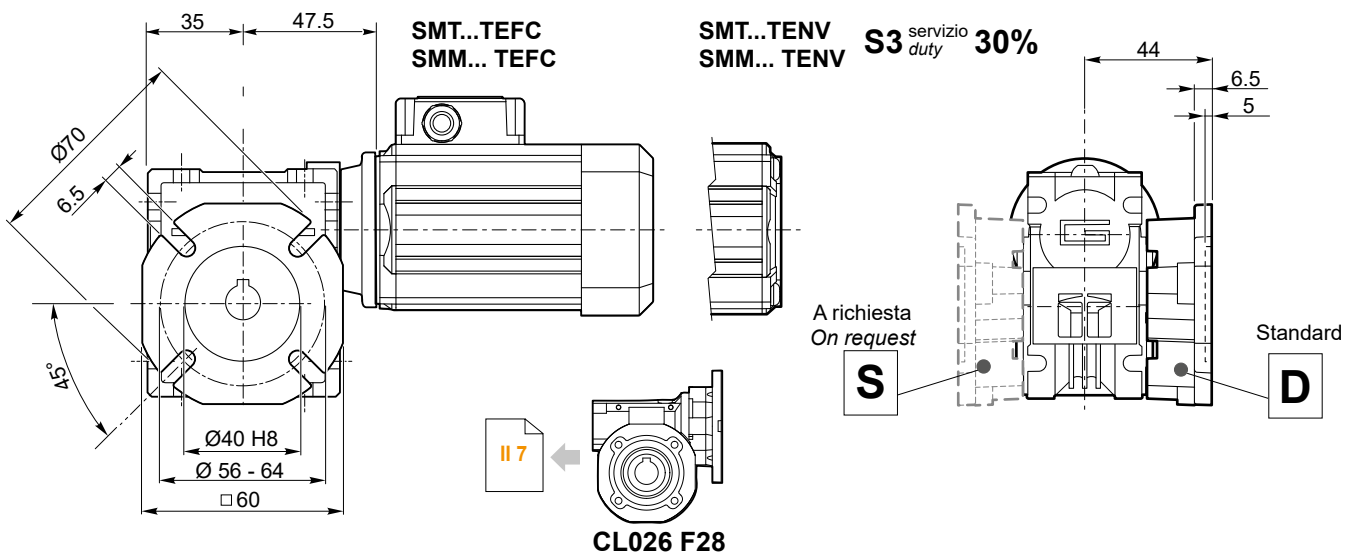

CM 026 .. F30

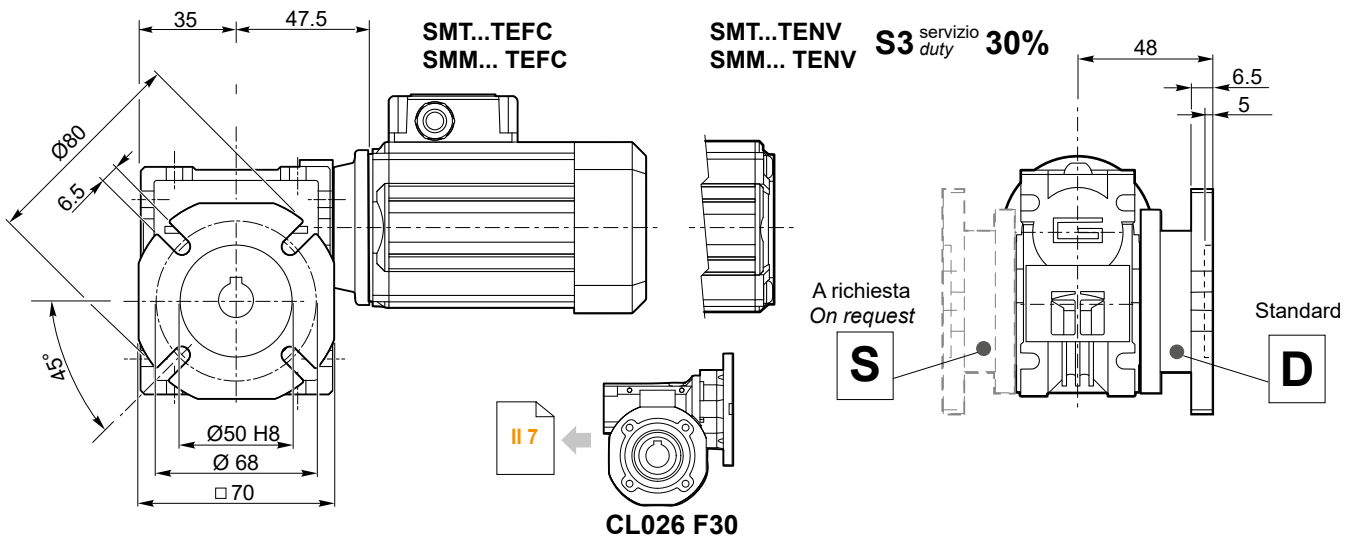

AC

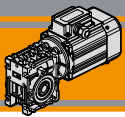

CM
CMP

Motoriduttori CA a vite senza fine
AC Wormgearmotors



Dimensioni

Dimensions

CM 026 .. F30C

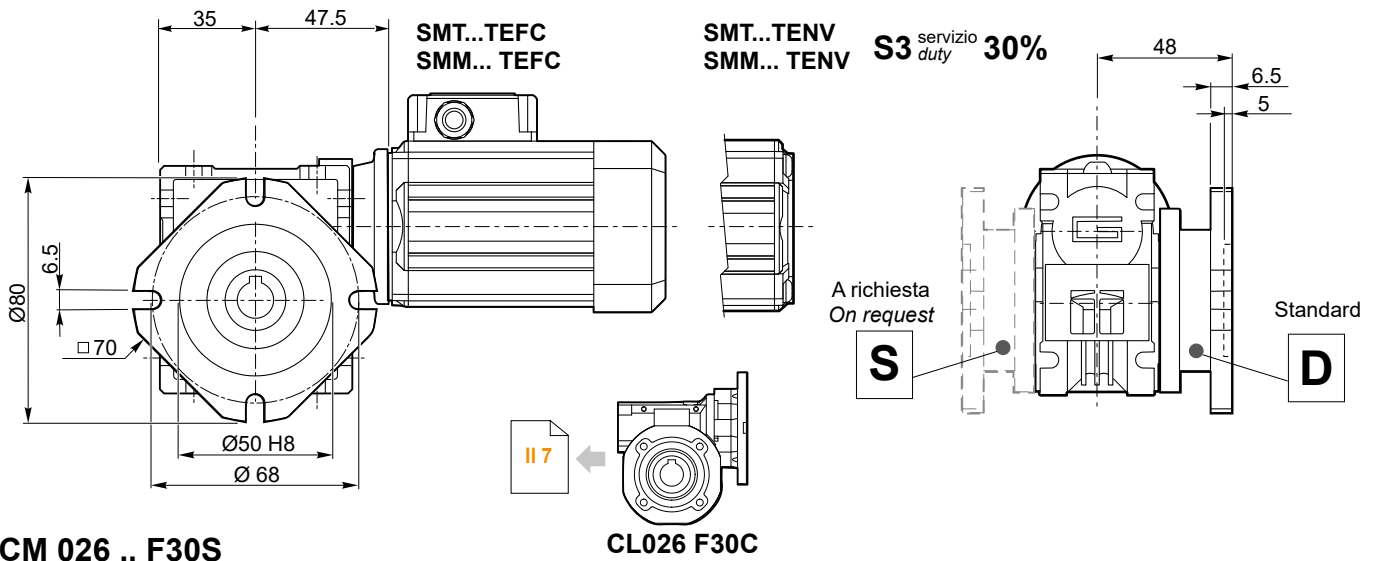

CM 026 .. F30S

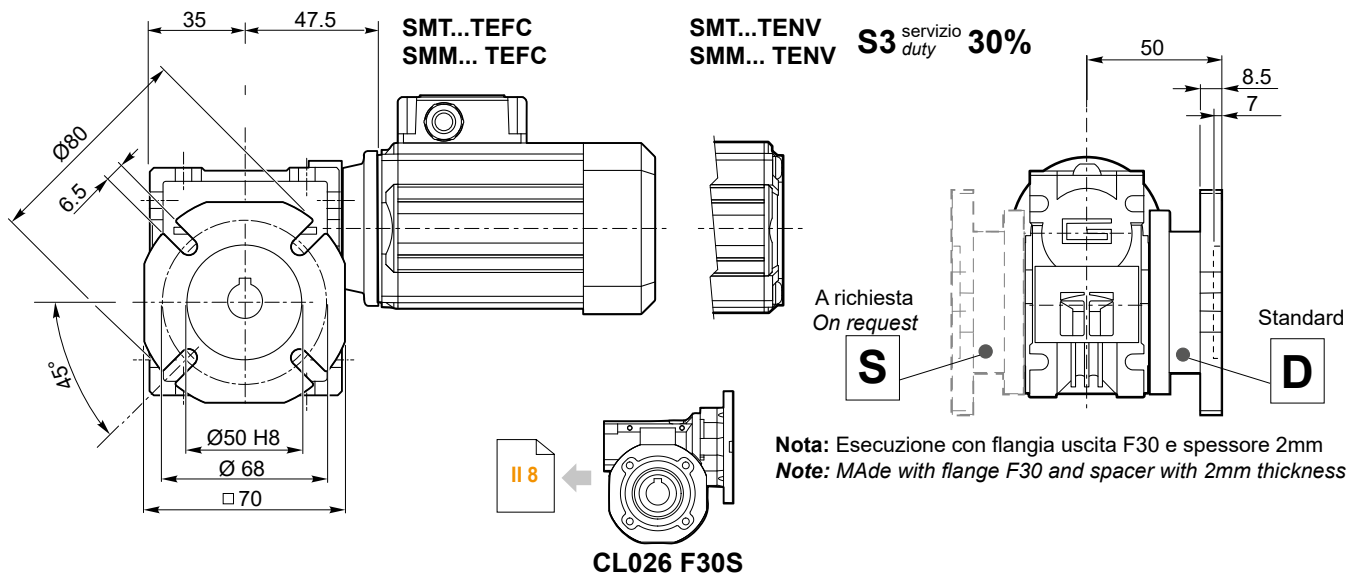

CM 026 .. F30SC

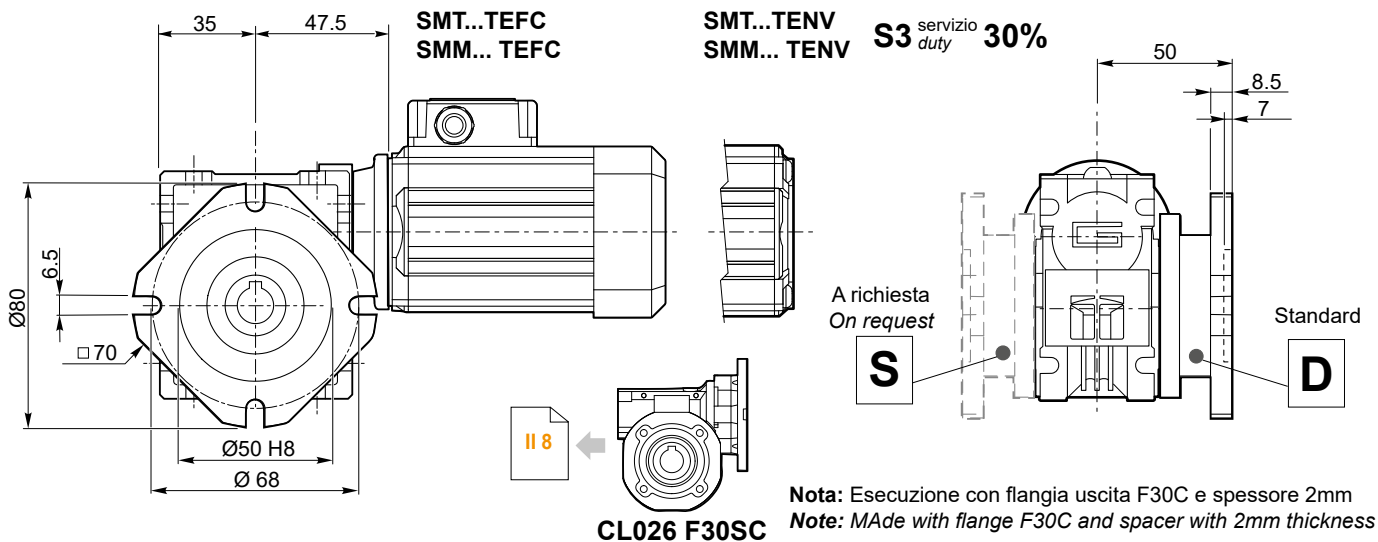

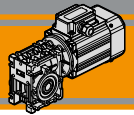

Dimensioni

Dimensions

CM 026 .. F100

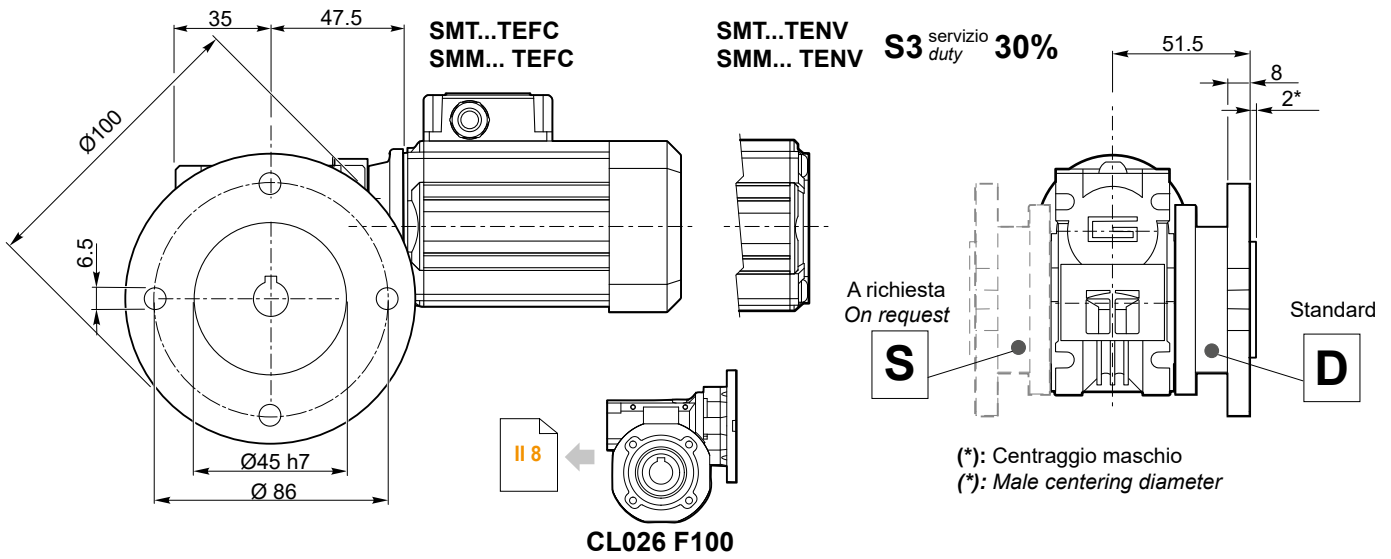

CM 030 ...U

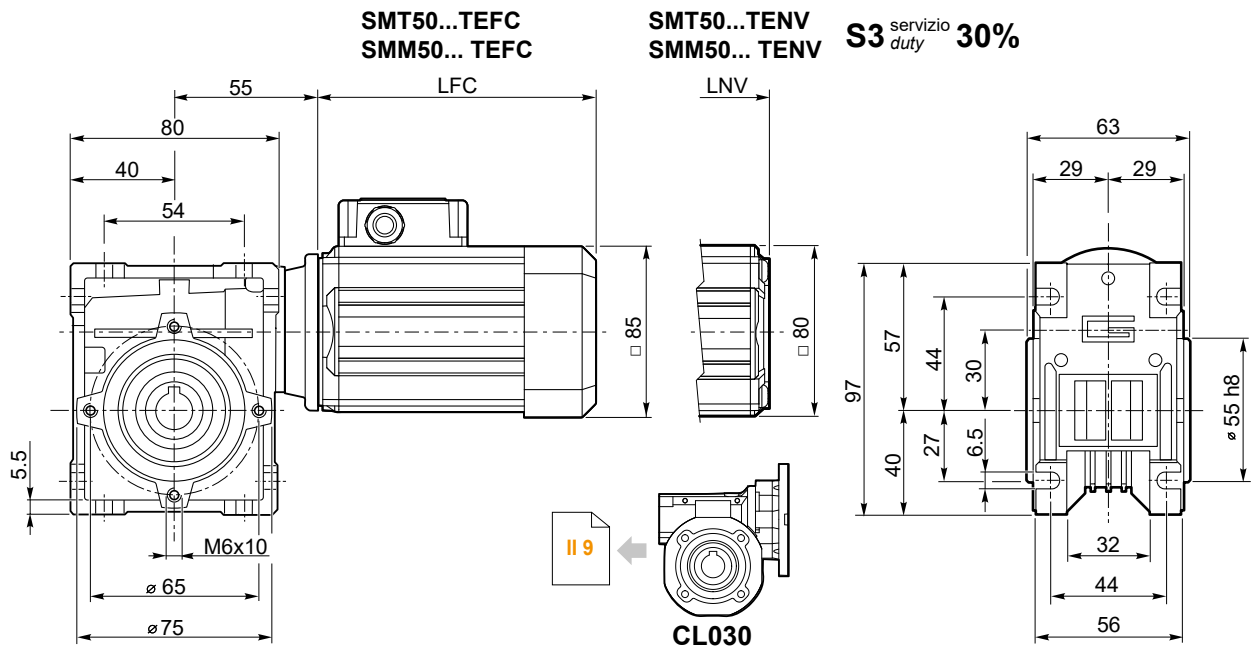

Albero lento cavo / Hollow output shaft

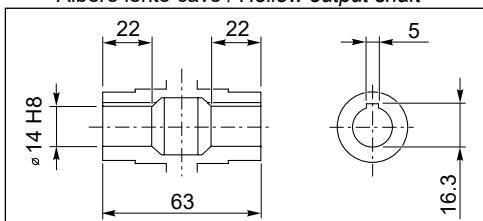

SMT	LFC	LNV	Kg	
5014	135.5	108.5	3.5	
5024	150.5	123.5	3.9	
5034	175.5	148.5	4.7	
5044	200.5	173.5	5.4	

SMM	LFC	LNV	Kg	
5014	150.5	123.5	3.9	
5024	175.5	148.5	4.7	
5034	200.5	173.5	5.4	

Nota: il condensatore sarà fornito a corredo
Note: the capacitor will be supplied separately

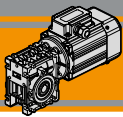

CM
CMP

Dimensioni

Dimensions

CM 030 ...U

SMT56...TEFC
SMM56... TEFC

SMT56...TENV
SMM56... TENV

S3 servizio 30%
duty

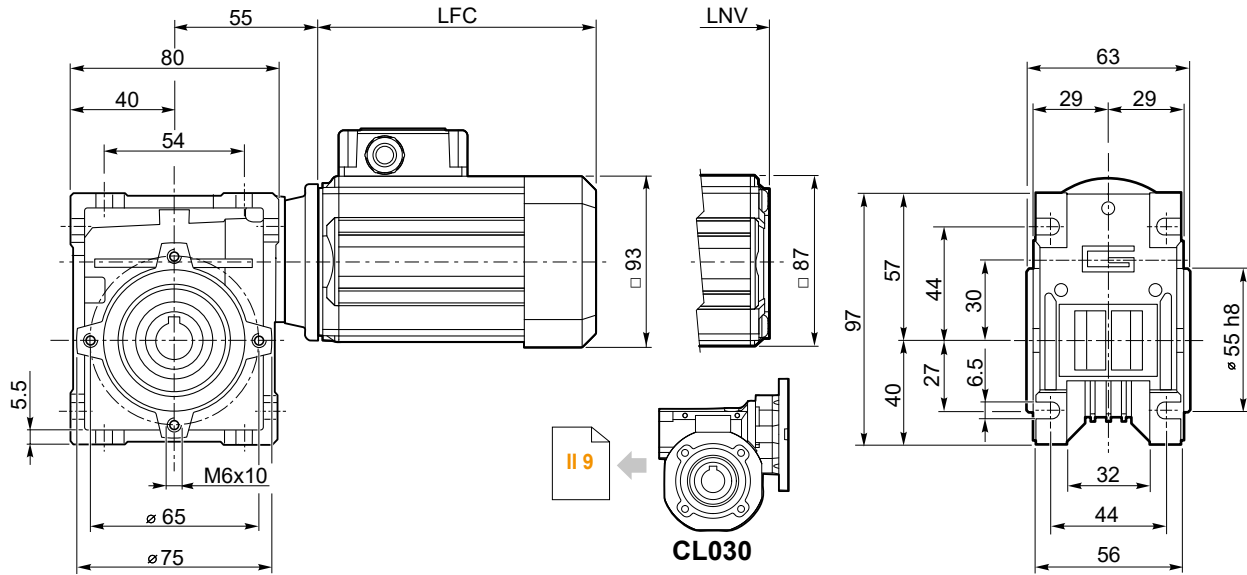

Albero lento cavo / Hollow output shaft

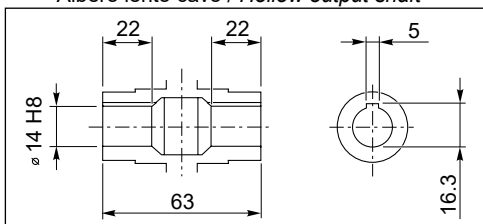

SMT	LFC	LNV	Kg	
5624	141	117	4	
5634	151	127	4.4	
5644	186	162	5.6	
5654	206	182	6.3	

SMM	LFC	LNV	Kg	
5624	151	127	4.3	
5634	171	147	4.9	
5644	206	182	6.2	

Nota: il condensatore sarà fornito a corredo
Note: the capacitor will be supplied separately

CM 030 ...U

SMT63...TEFC
SMM63... TEFC

SMT63...TENV
SMM63... TENV

S3 servizio 30%
duty

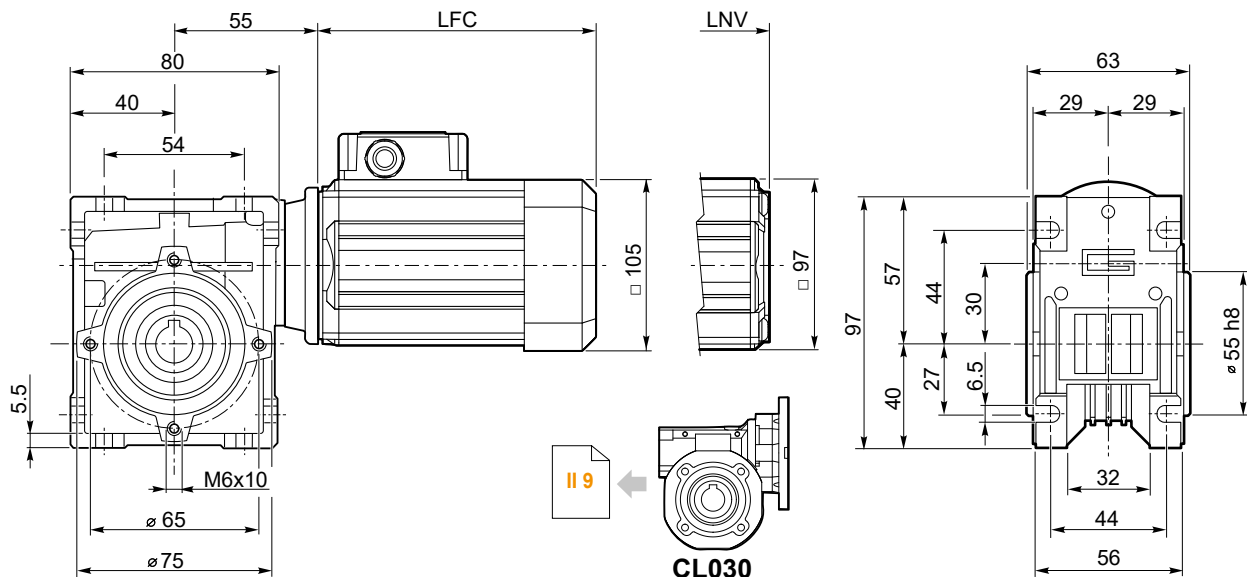

Albero lento cavo / Hollow output shaft

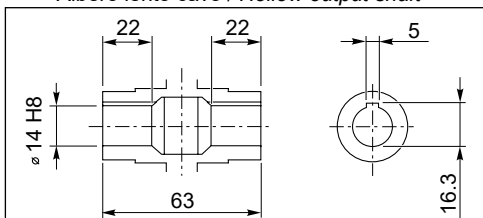

SMT	LFC	LNV	Kg	
6324	165.5	138.5	5.5	
6334	180.5	153.5	6.2	
6344	205.5	178.5	7.4	

SMM	LFC	LNV	Kg	
6324	180.5	153.5	6.3	
6334	205.5	178.5	7.5	

Nota: il condensatore sarà fornito a corredo
Note: the capacitor will be supplied separately

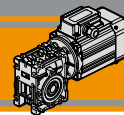

Dimensioni

Dimensions

CMP 056/030 ...U

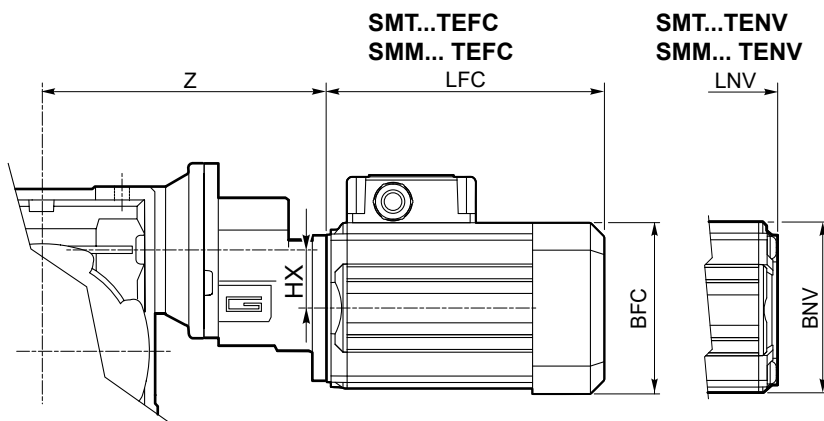

S3 servizio duty 30%

	HX	Z
056/030	30.5	124

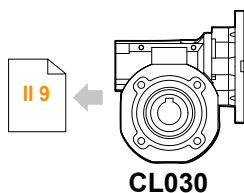

SMT	BFC	BNV	LFC	LNV
5014	□ 85	□ 80	135.5	108.5
5024			150.5	123.5
5034			175.5	148.5
5044			200.5	173.5
5624	□ 93	□ 87	141	117
5634			151	127
5644			186	162
5654			206	182

SMM	BFC	BNV	LFC	LNV
5014	□ 85	□ 80	150.5	123.5
5024			175.5	148.5
5034			200.5	173.5
5624			□ 93	□ 87
5634	186	162		
5644	206	182		

Nota: il condensatore sarà fornito a corredo
Note: the capacitor will be supplied separately

CM 030 ... - F

CMP 056/030 ... - F

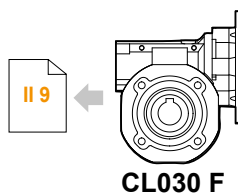
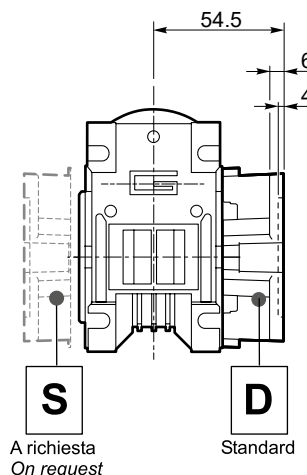
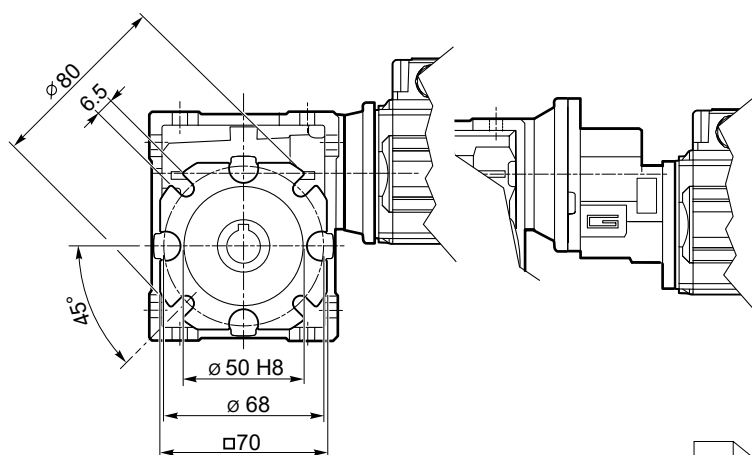

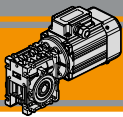

CM
CMP

Motoriduttori CA a vite senza fine
AC Wormgearmotors



Dimensioni

Dimensions

CM 040 ...U

SMT50...TEFC
SMM50... TEFC

SMT50...TENV
SMM50... TENV

S3 servizio 30%
duty

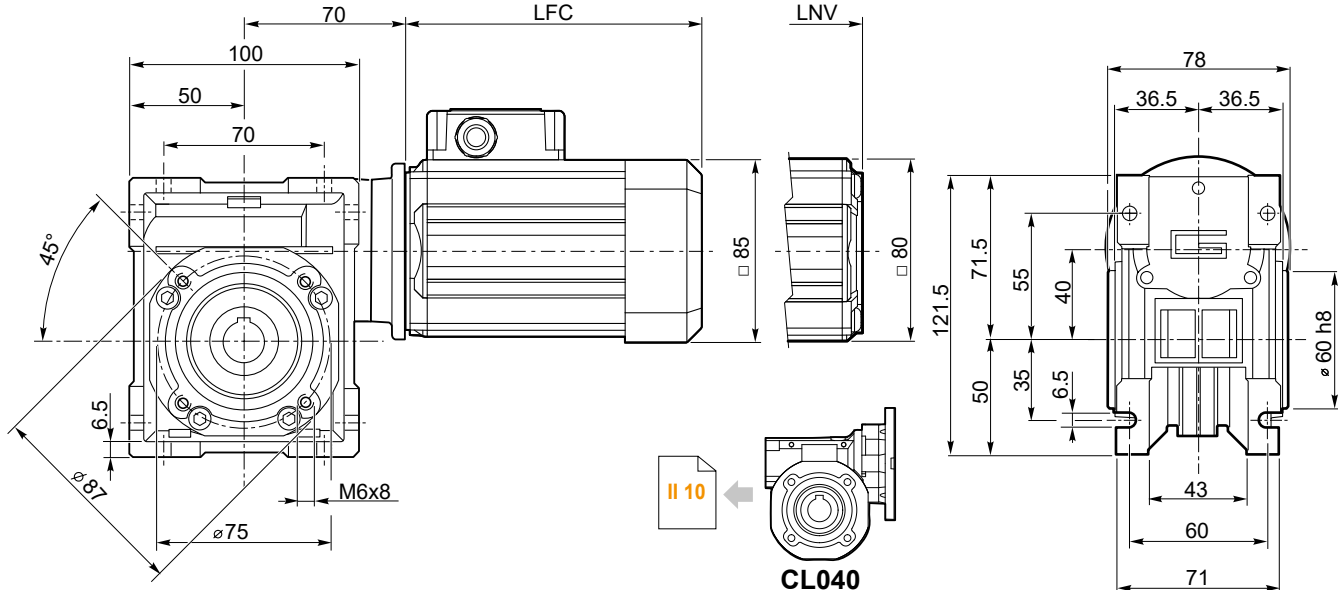

Albero lento cavo / Hollow output shaft

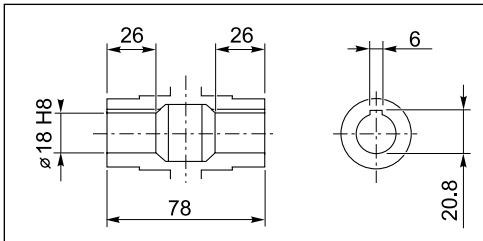

SMT	LFC	LNV	Kg	
5014	135.5	108.5	4.6	
5024	150.5	123.5	5	
5034	175.5	148.5	5.8	
5044	200.5	173.5	6.5	

SMM	LFC	LNV	Kg	
5014	150.5	123.5	5	
5024	175.5	148.5	5.8	
5034	200.5	173.5	6.5	

Nota: il condensatore sarà fornito a corredo
Note: the capacitor will be supplied separately

CM 040 ...U

SMT56...TEFC
SMM56... TEFC

SMT56...TENV
SMM56... TENV

S3 servizio 30%
duty

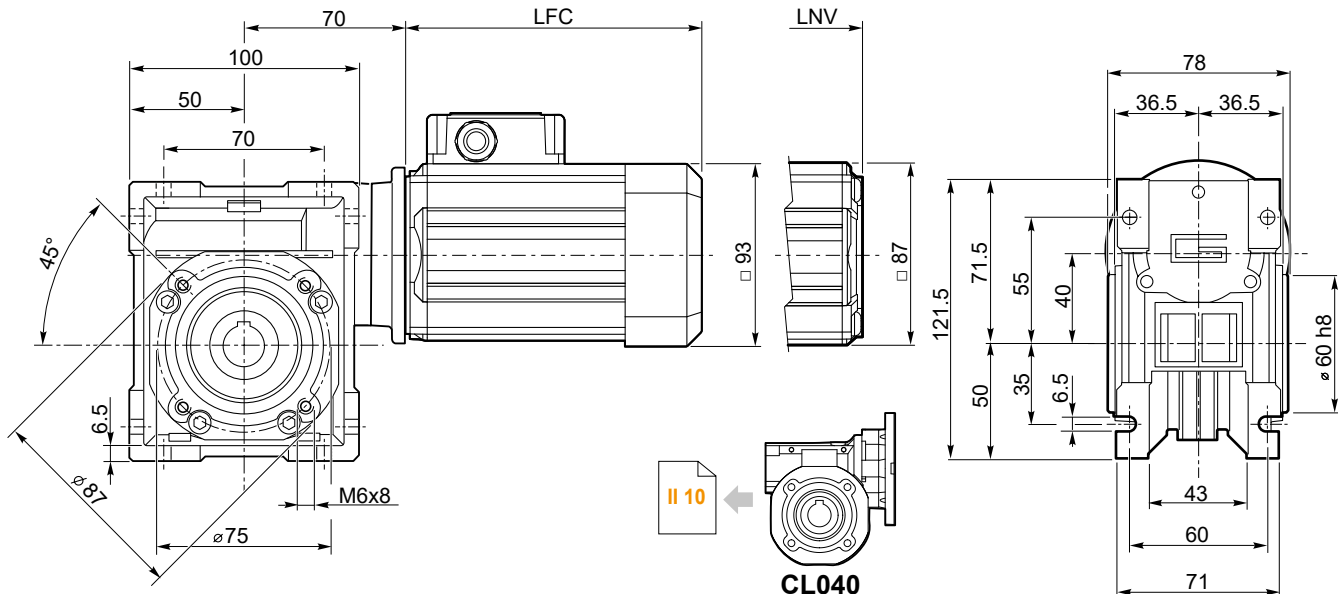

Albero lento cavo / Hollow output shaft

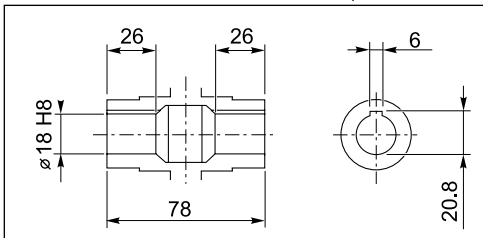

SMT	LFC	LNV	Kg	
5624	141	117	5.1	
5634	151	127	5.5	
5644	186	162	6.7	
5654	206	182	7.4	

SMM	LFC	LNV	Kg	
5624	151	127	5.4	
5634	171	147	6	
5644	206	182	7.3	

Nota: il condensatore sarà fornito a corredo
Note: the capacitor will be supplied separately

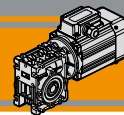

Dimensioni

Dimensions

CM 040 ...U

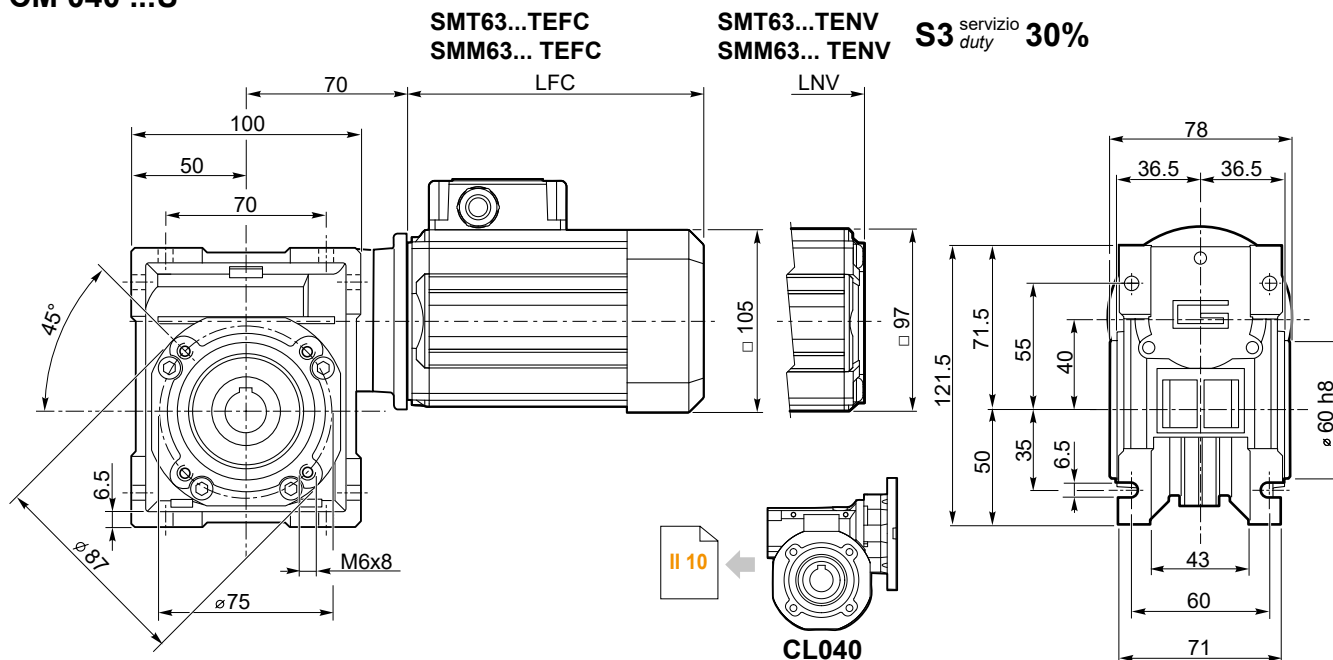

Albero lento cavo / Hollow output shaft

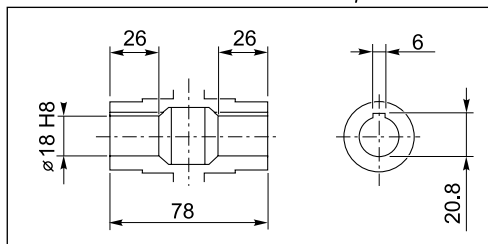

SMT	LFC	LNV	Kg	
6324	165.5	138.5	6.6	
6334	180.5	153.5	7.3	
6344	205.5	178.5	8.5	

SMM	LFC	LNV	Kg	
6324	180.5	153.5	7.4	
6334	205.5	178.5	8.6	

Nota: il condensatore sarà fornito a corredo
Note: the capacitor will be supplied separately

CMP .../040 ...U

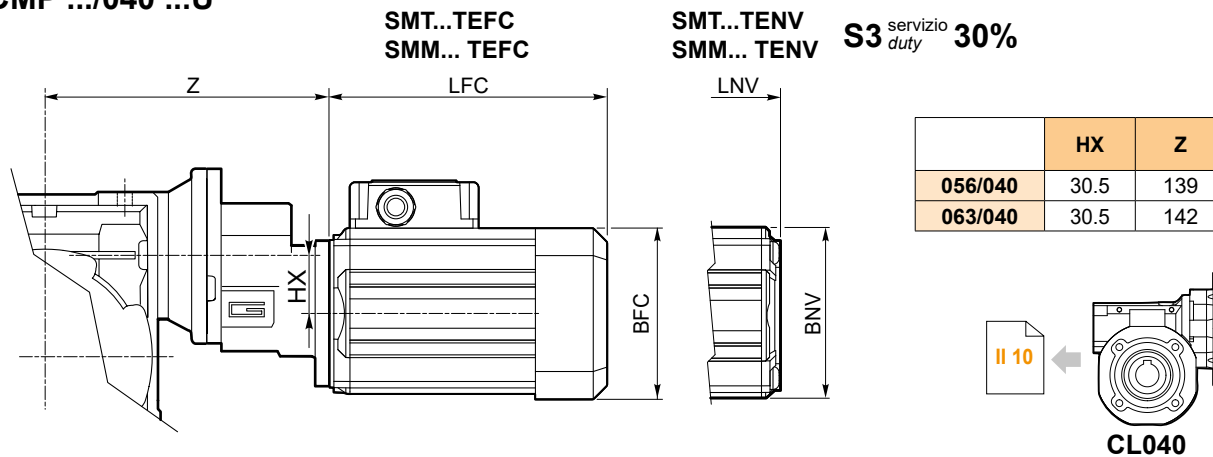

	HX	Z
056/040	30.5	139
063/040	30.5	142

SMT	BFC	BNV	LFC	LNV
5014			135.5	108.5
5024	□ 85	□ 80	150.5	123.5
5034			175.5	148.5
5044			200.5	173.5
5624			141	117
5634	□ 93	□ 87	151	127
5644			186	162
5654			206	182
6324			165.5	138.5
6334	□ 105	□ 97	180.5	153.5
6344			205.5	178.5

SMM	BFC	BNV	LFC	LNV
5014			150.5	123.5
5024	□ 85	□ 80	175.5	148.5
5034			200.5	173.5
5624			151	127
5634	□ 93	□ 87	186	162
5644			206	182
6324			180.5	153.5
6334	□ 105	□ 97	205.5	178.5

Nota: il condensatore sarà fornito a corredo
Note: the capacitor will be supplied separately

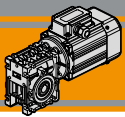

CM
CMP

Motoriduttori CA a vite senza fine
AC Wormgearmotors



Dimensioni

Dimensions

CM 040 ... - F

CMP .../040 ... - F

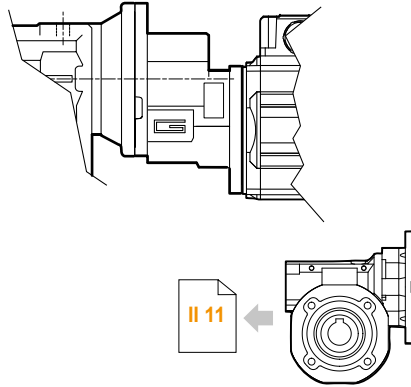
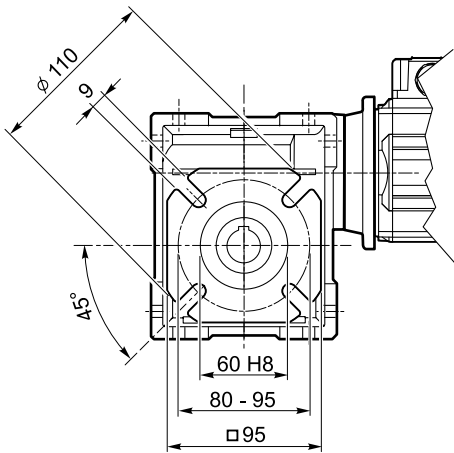

CL040 F

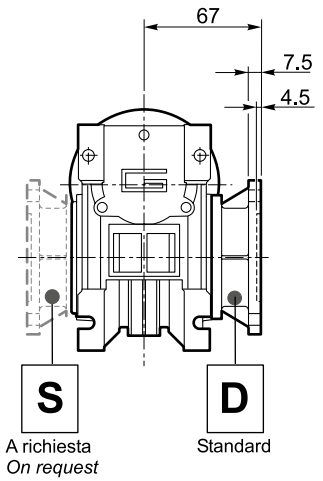

CM 040 ... - FB

CMP .../040 ... - FB

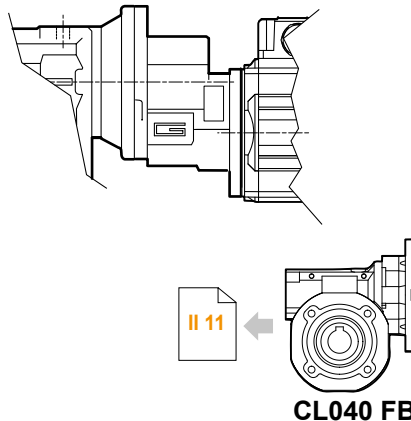
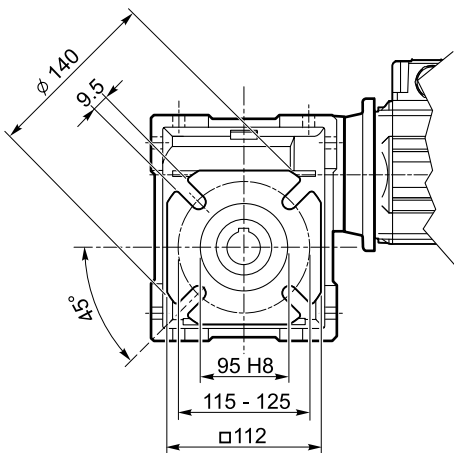

CL040 FB

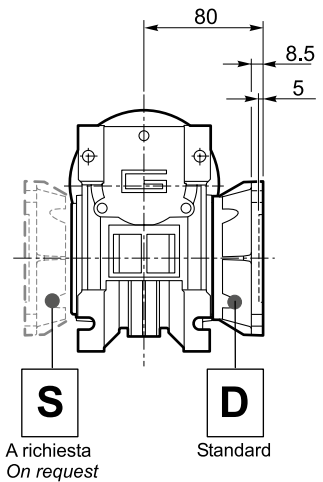

CM 040 ... - FL

CMP .../040 ... - FL

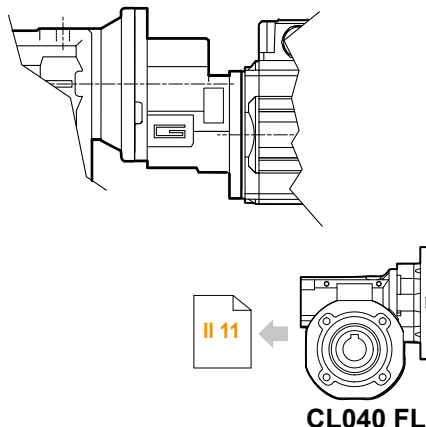
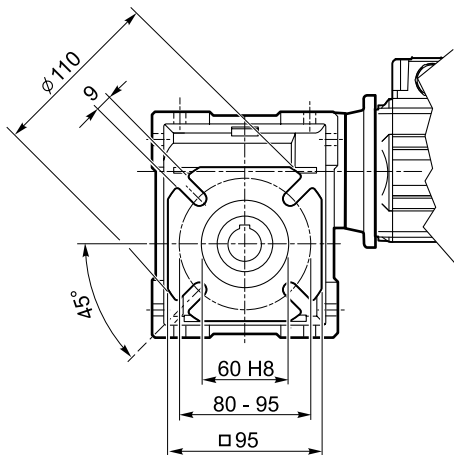

CL040 FL

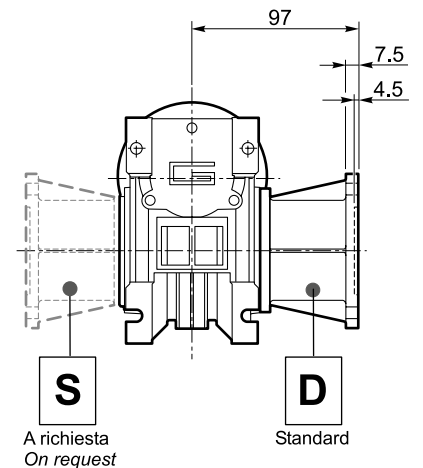

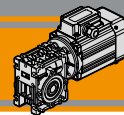

Opzioni

Options

VS - Vite sporgente / Extended input shaft

SC - Safety cover

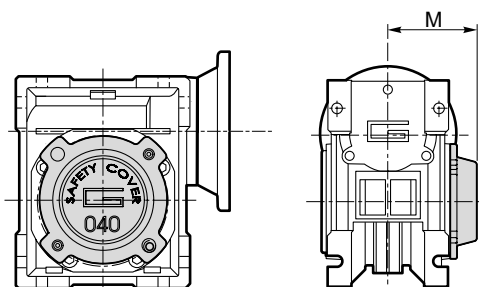
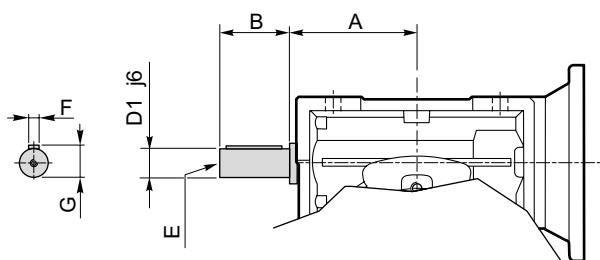

CM	CMP	A	B	D ₁ j ₆	E	F	G
030	056/030	45	20	9	M4	3	10.2
040	056/040 063/040	53	23	11	M5	4	12.5

CM	CMP	M
030	056/030	47
040	056/040 063/040	54.5

Costruito su richiesta
Built on request

Accessori

Accessories

Albero lento

Output shaft

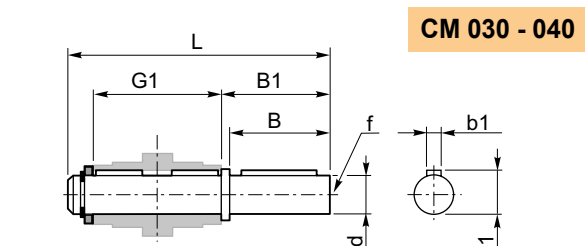
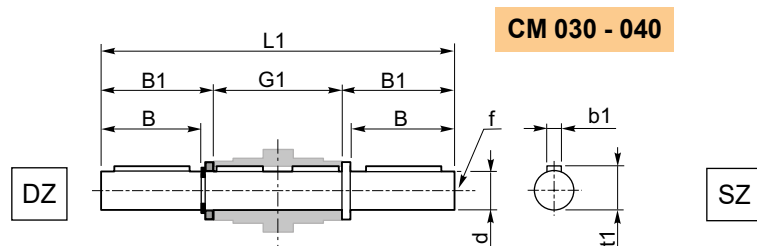

CM	CMP	d h ₇	B	B ₁	G ₁	L	L ₁	f	b ₁	t ₁
030	056/030	14	30	32.5	63	102	128	M6	5	16
040	056/040 063/040	18	40	43	78	128	164	M6	6	20.5

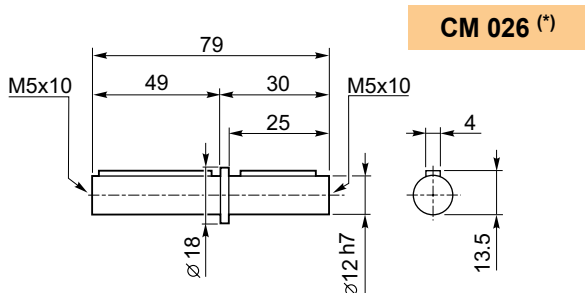

(*)
Nota: disponibile solo per cavo uscita Ø12
Note: available for output hollow shaft Ø12 only

Braccio di reazione

Torque arm

CM	CMP	K ₁	G	KG	KH	R
030	056/030	85	14	23	8	15
040	056/040 063/040	100	14	31	10	18

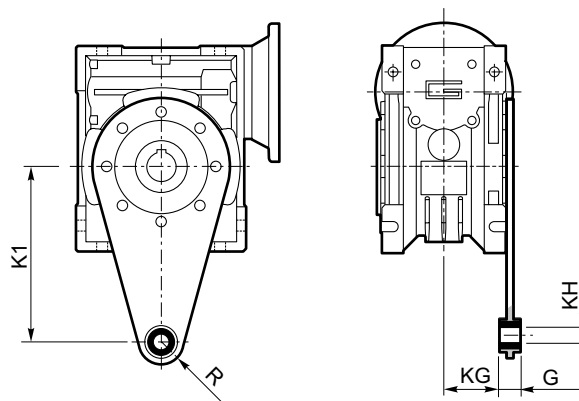

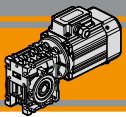

Note/Notes

MINI  **TECNO**
small but strong

CMM

Motoriduttori CA combinati a vite senza fine
AC Double reduction wormgearmotors



MINI  **TECNO** brand of
TRANSTECNO[®]



AC

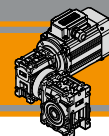

Indice	Index	Pag. Page
Caratteristiche tecniche	<i>Technical features</i>	AF2
Designazione	<i>Classification</i>	AF2
Simbologia	<i>Symbols</i>	AF3
Esecuzioni di montaggio	<i>Mounting executions</i>	AF3
Combinazioni rapporti	<i>Combination ratio</i>	AF3
Lubrificazione	<i>Lubrication</i>	AF3
Dati tecnici	<i>Technical data</i>	AF4
Motori applicabili	<i>Motor adapters</i>	AF5
Dimensioni	<i>Dimensions</i>	AF6
Accessori	<i>Accessories</i>	AF10
Opzioni	<i>Options</i>	AF10

Questa sezione annulla e sostituisce ogni precedente edizione o revisione. Qualora questa sezione non Vi sia giunta in distribuzione controllata, l'aggiornamento dei dati ivi contenuto non è assicurato. **In tal caso la versione più aggiornata è disponibile sul nostro sito internet www.transtecno.com**

This section replaces any previous edition and revision. If you obtained this catalogue other than through controlled distribution channels, the most up to date content is not guaranteed. In this case the latest version is available on our web site www.transtecno.com

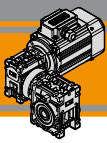

CMM

Motoriduttori CA combinati a vite senza fine
AC Double reduction wormgearmotors

MINI
TECNO

Caratteristiche tecniche

Technical features

Le caratteristiche principali dei motoriduttori CMM sono:

CMM gearmotors range has the following main features:

- Costruzione compatta
- Motorizzazioni in corrente alternata monofase e trifase
- Carcassa motore estrusa in alluminio anodizzato nero
- Carcasse dei riduttori in pressofusione di alluminio
- Motore elettrico AC con grado di protezione IP66
- Lubrificazione permanente con olio sintetico
- Disponibili sia nella versione ventilata TEFC (servizio S1) che non ventilata TENV (servizio S3)
- Protezioni termiche per le taglie 56 e 63
- SMT56 e SMT63 adatti al funzionamento con alimentazione da inverter

- Compact design
- AC single phase and three phase motors available
- Motor extruded aluminum housing black anodized
- Gearbox die-cast aluminum housing
- AC electric motor in IP66 protection Standard
- Permanent synthetic oil long-life lubrication
- Fan cooled TEFC (duty S1) and not ventilated TENV (duty S3) versions available
- Thermal protection for motor sizes 56 and 63
- SMT56 and SMT63 are suitable for running with inverter

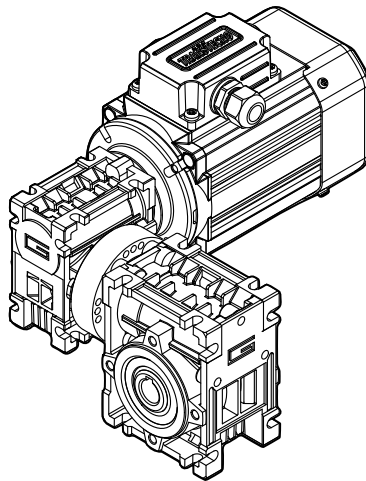

Designazione

Classification

RIDUTTORE / GEARBOX										
CMM	030/040	FD	150	63	B5	SZDX	BRSX	90	US1	VS
Tipo Type	Grandezza Size	Versione Version	Rapporto Ratio	IEC 	Forma costruttiva Version	Albero di uscita Output shaft	Braccio di reazione Torque arm	Angolo Angle	Esecuzione di montaggio Mounting execution	Opzioni Options
	026/026 026/026 (D11) 026/026 (D14) 026/030 026/040 030/040	U F...	vedi tabelle see tables	56.. 63..	B5 B14	SZDX SZSX DZ	BRDX BRSX *	0° 90° 180° 270°	UB1 UB2 US1 US2 UV1 UV2 UC1 UC2	VS1 VS2

* NOTA: il braccio di reazione viene fornito smontato.
NOTE: the torque arm will be supplied not assembled.

Versione Riduttore
Gearbox Version

U F...D F...S

Albero di uscita
Output shaft

SZDX SZSX DZ

Braccio di reazione
Torque arm

BRDX BRSX

Angolo
Angle

0° 90° 180°

270° 270°

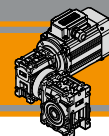

Designazione

Classification

SMT	63	2	4	B14	230-400 V	50 Hz	TEFC	T1
Tipo Type	Grandezza Size	Indicativo potenza Power coefficient	Poli Poles	Forma costruttiva Version	Tensione Voltage	Frequenza Frequency	Ventilazione Fan cooling	Pos. morsetteria Terminal box pos.
SMT trifase threephase	vedi tabelle see tables	1-2-3-4-5	4	B14	230-400 V	50Hz 60Hz	TEFC TENV	T1 (Std)

SMM	63	2	4	B14	230 V	50 Hz	TEFC	T1
Tipo Type	Grandezza Size	Indicativo potenza Power coefficient	Poli Poles	Forma costruttiva Version	Tensione Voltage	Frequenza Frequency	Ventilazione Fan cooling	Pos. morsetteria Terminal box pos.
SMM monofase singlephase	vedi tabelle see tables	1-2-3-4	4	B14	230 V	50Hz	TEFC TENV	T1 (Std)

Simbologia

Symbols

n_1 [min ⁻¹]	Velocità in ingresso / <i>Input speed</i>	M_2 [Nm]	Coppia in uscita in funzione di P_1 / <i>Output torque referred to P_1</i>
n_2 [min ⁻¹]	Velocità in uscita / <i>Output speed</i>	sf	Fattore di servizio / <i>Service factor</i>
i	Rapporto di riduzione / <i>Ratio</i>	R_2 [N]	Carico radiale ammissibile in uscita / <i>Permitted output radial load</i>
P_1 [kW]	Potenza in entrata / <i>Input power</i>	A_2 [N]	Carico assiale ammissibile in uscita / <i>Permitted output axial load</i>

Esecuzioni di montaggio

Mounting executions

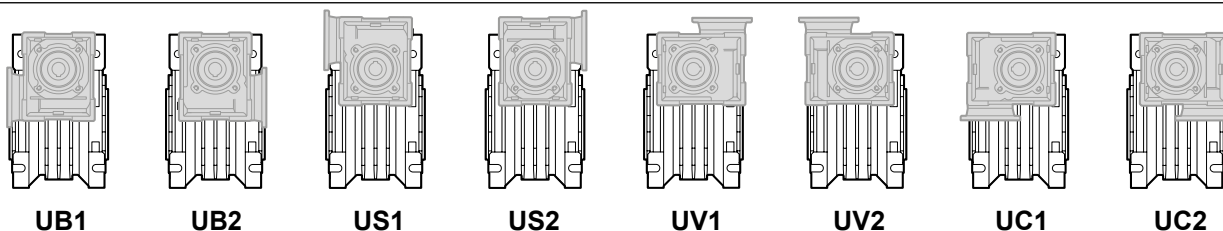

Combinazioni rapporti

Combination ratio

CMM 026/026 - CMM 026/030 - CMM 026/040												
i (i ₁ x i ₂)												
	150	225	300	450	600	900	1200	1500	1800	2400	3000	3600
i ₁	10	15	10	15	20	30	40	50	60	60	60	60
i ₂	15	15	30	30	30	30	30	30	30	40	50	60

CMM 030/040														
i (i ₁ x i ₂)														
	150	200	250	300	400	500	600	750	900	1200	1500	1800	2400	3000
i ₁	10	10	10	10	10	10	20	25	30	40	50	60	60	60
i ₂	15	20	25	30	40	50	30	30	30	30	30	30	40	50









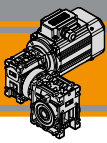









Lubrificazione

Lubrication

Tutti i motoriduttori nelle taglie 26, 30, 40 sono forniti completi di lubrificante sintetico viscosità 320, pertanto possono essere installati in qualunque posizione di montaggio e non necessitano di manutenzione.

Permanent synthetic oil long-life lubrication (viscosity grade 320) makes it possible to use the gearmotors size 26, 30, 40 in all mounting positions; for this reason they can be installed in any assembly position and do not require maintenance.

**Dati tecnici****Technical data**

P_1 [kW]	n_2 [min ⁻¹]	M_2 [Nm]	sf	i			P_1 [kW]	n_2 [min ⁻¹]	M_2 [Nm]	sf	i											
0.04							0.06															
SMT5014	9.3	23	1.1	150	CMM 026/026		SMT5024	9.3	36	2.4	150	CMM 030/040										
SMM5014	6.2	32	0.8	225			SMT5024	7.0	46	1.6	200			SMM5024	7.0	46	1.6	200				
(1400 min ⁻¹)	4.7	34	0.8	300			(1400 min ⁻¹)	5.6	55	1.2	250			(1400 min ⁻¹)	4.7	59	1.5	300				
	2.3	34	0.8	600				3.5	72	1.0	400				2.8	81	0.8	500				
	1.6	34	0.8	900				2.3	105	0.9	600				1.9	113	0.8	750				
	1.2	34	0.8	1200				1.6	113	0.8	900											
	0.9	34	0.8	1500																		
	0.8	34	0.8	1800																		
	0.6	28	0.8	2400																		
	0.5	25	0.8	3000																		
	0.4	23	0.8	3600																		
	9.3	23	1.7	150			CMM 026/030		SMT5034	9.3	49			0.8	150	CMM 026/030						
	6.2	32	1.2	225					SMT5034	6.2	49			0.8	225			SMM5034	6.2	49	0.8	225
	4.7	37	1.1	300					(1400 min ⁻¹)	5.6	53			1.6	150			(1400 min ⁻¹)	4.7	59	1.5	300
	3.1	50	0.8	450						6.2	74			1.2	225				3.1	113	0.8	450
	2.3	50	0.8	600						4.7	87			1.0	300				2.3	113	0.8	600
	1.6	50	0.8	900						3.1	113			0.8	450							
	1.2	50	0.8	1200						2.3	113			0.8	600							
	0.9	50	0.8	1500																		
	0.8	50	0.8	1800																		
	0.6	43	0.8	2400																		
	0.5	38	0.8	3000																		
	0.4	34	0.8	3600																		
	9.3	23	3.7	150	CMM 026/040				SMT5044	9.3	70	1.2	150	CMM 030/040								
	6.2	33	2.6	225					SMT5044	6.2	99	0.9	225					SMT5634	6.2	109	0.8	225
	4.7	39	2.3	300					(1400 min ⁻¹)	4.7	113	0.8	300					(1400 min ⁻¹)	9.3	107	0.8	150
	3.1	55	1.6	450						9.3	71	1.2	150						7.0	93	0.8	200
	2.3	69	1.3	600						7.0	92	0.8	200									
	1.6	92	1.0	900						5.6	84	0.8	250									
	1.2	113	0.8	1200				4.7	113	0.8	300											
	0.9	113	0.8	1500																		
	0.8	113	0.8	1800																		
	0.6	93	0.8	2400																		
	0.5	85	0.8	3000																		
	0.4	78	0.8	3600																		
	9.3	24	3.7	150			CMM 030/040		SMT5644	9.3	105	0.8	150			CMM 026/040						
	7.0	31	2.4	200					SMT5644	6.2	109	0.8	225					SMT6324	9.3	107	0.8	150
	5.6	37	1.8	250					(1400 min ⁻¹)	9.3	107	0.8	150					(1400 min ⁻¹)	7.0	93	0.8	225
	4.7	39	2.3	300						7.0	93	0.8	200									
	3.5	48	1.6	400																		
	2.8	54	1.3	500																		
	2.3	70	1.3	600																		
	1.9	84	1.1	750																		
	1.6	94	1.0	900																		
	1.2	113	0.8	1200																		
	0.9	113	0.8	1500																		
	0.8	113	0.8	1800																		
	0.6	93	0.8	2400																		
	0.5	85	0.8	3000																		
	0.4	78	0.8	3600																		
0.06									0.18													
SMT5024	9.3	33	0.8	150	CMM 026/026				SMT5644	9.3	105	0.8	150	CMM 026/040								
SMM5024	6.2	33	0.8	225					SMM5644	6.2	109	0.8	225					SMT6324	9.3	107	0.8	150
(1400 min ⁻¹)	9.3	34	1.1	150			(1400 min ⁻¹)	9.3	107	0.8	150	(1400 min ⁻¹)	7.0			93	0.8	225				
	6.2	48	0.8	225	CMM 026/030		SMT6334	7.0	93	0.8	225	CMM 030/040										
	4.7	50	0.8	300			SMM6334	7.0	93	0.8	225			SMT6334	7.0	93	0.8	225				
	9.3	35	2.5	150			(1400 min ⁻¹)	9.3	107	0.8	150			(1400 min ⁻¹)	7.0	93	0.8	225				
	6.2	50	1.8	225	CMM 026/040		SMT5654	9.3	109	0.8	150	CMM 030/040										
	4.7	58	1.5	300			SMT6334	7.0	93	0.8	225			SMT5654	9.3	109	0.8	150				
	3.1	82	1.1	450			(1400 min ⁻¹)	9.3	107	0.8	150			(1400 min ⁻¹)	7.0	93	0.8	225				
	2.3	104	0.9	600				7.0	93	0.8	225											
	1.6	113	0.8	900																		

Nota: Verificare sempre che la coppia M2 utilizzata non ecceda il valore indicato nelle caselle in grigio

Note: Please check that the output torque M2 does not exceed the value into the grey areas

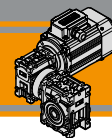

Motori applicabili

Motor adapters

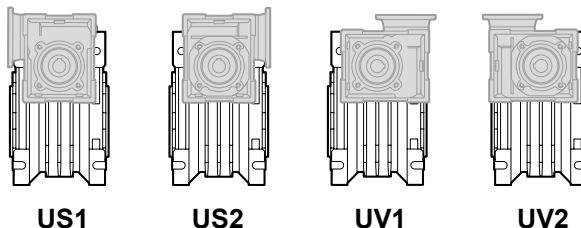

		SMT		SMM	
		5014	5624	5014	5624
		5024	5634	5024	5634
		5034	5644	5034	5644
		5044	5654		
CM	026/026	150 - 3600		150 - 3600	

150 - 3600 Rapporti di riduzione i / Ratio i

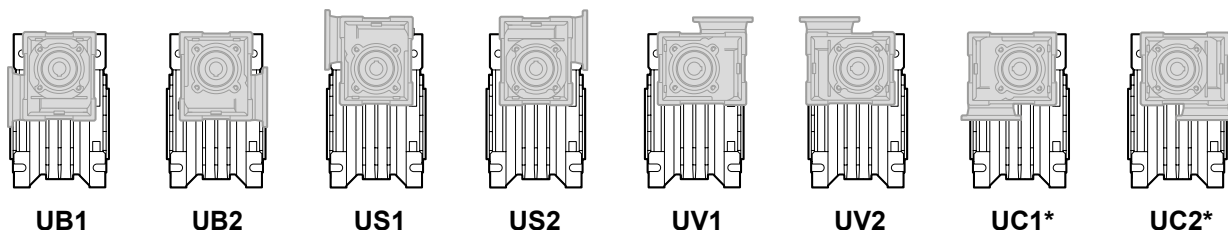

*: Solo / only SMT 50 - SMM50

		SMT		SMM	
		5014	5624	5014	5624
		5024	5634	5024	5634
		5034	5644	5034	5644
		5044	5654		
CM	026/030	150 - 3600		150 - 3600	
	026/040				

150 - 3600 Rapporti di riduzione i / Ratio i

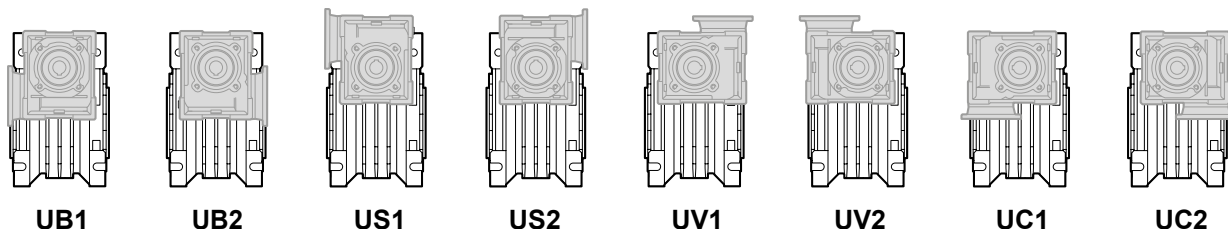

		SMT			SMM		
		5014	5624	6324	5014	5624	6314
		5024	5634	6334	5024	5634	6324
		5034	5644	6344	5034	5644	6334
		5044	5654				
CM	030/040	75 - 3600		75-1500	75 - 3600		75-1500

75 - 3600 Rapporti di riduzione i / Ratio i

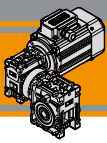

CMM

Motoriduttori CA combinati a vite senza fine
AC Double reduction wormgearmotors



Dimensioni

Dimensions

CMM..U - CMM..F...																	
	A	C	D _{H8}	E	F	G	G1	H	H1	I	I1	K	L	M	N _{h8}	N1	N2
026/026 (D11)			11														
026/026	45	70	12	83	22	47.5	50	35	34	26	26	34	42	55	45	22.5	21
026/026 (D14)			14														
026/030	54	80	14	97	32	47.5	63	40	34	30	26	44	56	65	55	29	21
026/040	70	100	18	121.5	43	47.5	78	50	34	40	26	60	71	75	60	36.5	21

CMM..U - CMM..F...														
	O	P	Q	R	R1	S	T	V	Z	KE	a	b	t	Kg
026/026 (D11)												4	12.8	
026/026	6	—	37	49	49	5	15	21	76	7	—	4	13.8	1.6
026/026 (D14)												5	16.2	
026/030	6.5	75	44	57	49	5.5	22	27	81	M6x10(n.4)	90°	5	16.3	2.4
026/040	6.5	87	55	71.5	49	6.5	26	35	91.5	M6x8(n.4)	45°	6	20.8	3.5

	CMM..F						CMM..F28						CMM..F30						CMM..F30S ⁽¹⁾														
	a1	KA	KB	KC	KM	KN _{H8}	KO	KP	KQ	KA	KB	KC	KM	KN _{H8}	KO	KP	KQ	KA	KB	KC	KM	KN _{H8}	KO	KP	KQ	KA	KB	KC	KM	KN _{H8}	KO	KP	KQ
026 (D11)	45°	45	6	4.5	55-69	40	6.5 (n.4)	75	70	44	6.5	5	56-64	40	6.5	70	60	48	6.5	5	68	50	6.5	80	70	50	8.5	7	68	50	6.5	80	70
026																																	
026 (D14)																																	

(1): F30S eseguita con F30 e distanziale di spessore 2 mm / F30S made with F30 and spacer with 2mm thickness

	CMM..F30C						CMM..F30SC ⁽²⁾						CMM..F100													
	a1	KA	KB	KC	KM	KN _{H8}	KO	KP	KQ	KA	KB	KC	KM	KN _{H8}	KO	KP	KQ	KA	KB	KC*	KM	KN _{H7}	KO	KP	KQ	
026 (D11)																										
026	-	48	6.5	7	68	50	6.5	80	70	50	8.5	7	68	50	6.5	80	70	51.5	8	2*	86	45	6.5	100	-	
026 (D14)																										

(2): F30SC eseguita con F30C e distanziale di spessore 2 mm / F30SC made with F30C and spacer with 2mm thickness

	CMM..F						CMM..FB						CMM..FL												
	a1	KA	KB	KC	KM	KN _{H8}	KO	KP	KQ	KA	KB	KC	KM	KN _{H8}	KO	KP	KQ	KA	KB	KC	KM	KN _{H8}	KO	KP	KQ
026/030	45°	54.5	6	4	68	50	6.5(n.4)	80	70								—								
026/040	45°	67	7.5	4.5	80-95	60	9(n.4)	110	95	80	8.5	5	115-125	95	9.5(n.4)	140	112	97	7.5	4.5	80-95	60	9(n.4)	110	95

SMT	BFC	BNV	LFC	LNV
5014			135.5	108.5
5024	□ 85	□ 80	150.5	123.5
5034			175.5	148.5
5044			200.5	173.5
5624			141	117
5634	□ 93	□ 87	151	127
5644			186	162
5654			206	182

SMM	BFC	BNV	LFC	LNV
5014			150.5	123.5
5024	□ 85	□ 80	175.5	148.5
5034			200.5	173.5
5624			151	127
5634	□ 93	□ 87	186	162
5644			206	182

Nota: il condensatore sarà fornito a corredo
Note: the capacitor will be supplied separately

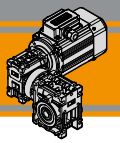

Dimensioni

Dimensions

CMM 026/... U

S3 ^{servizio} _{duty} 30%

SMT...TENV
SMM... TENV

SMT...TEFC
SMM... TEFC

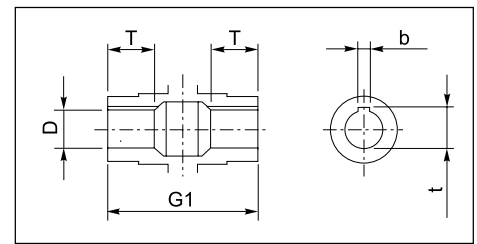
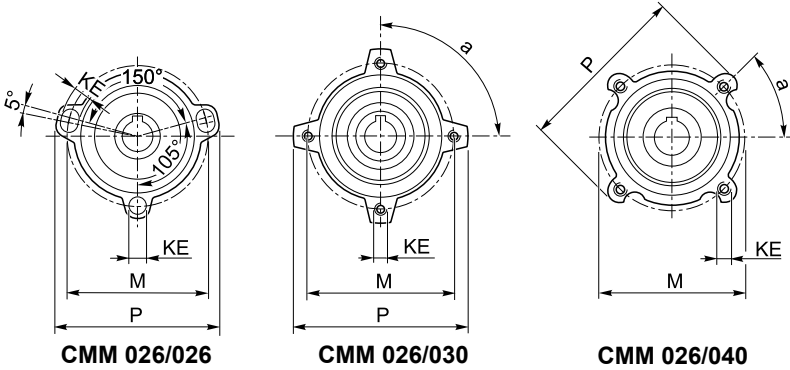
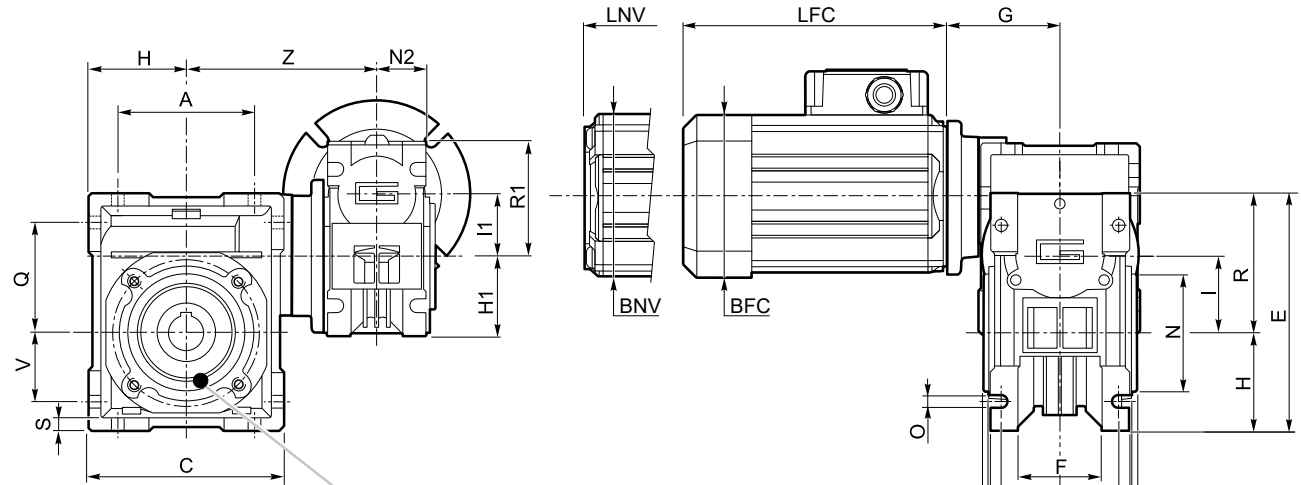

Albero lento cavo / Hollow output shaft

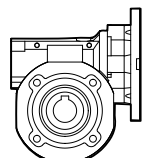
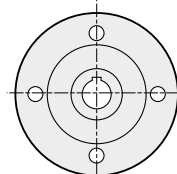
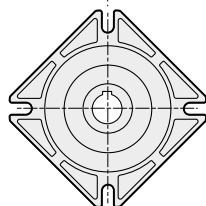
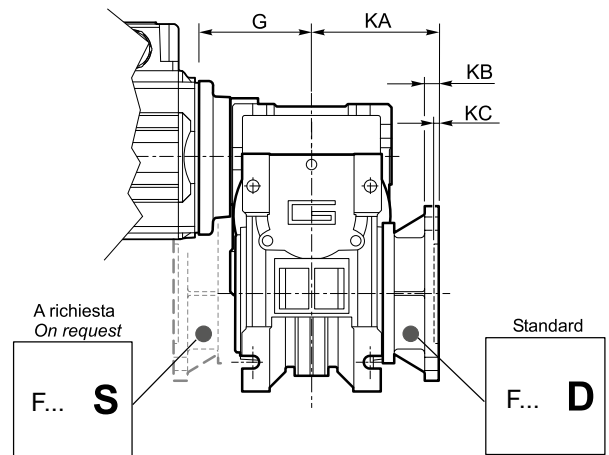
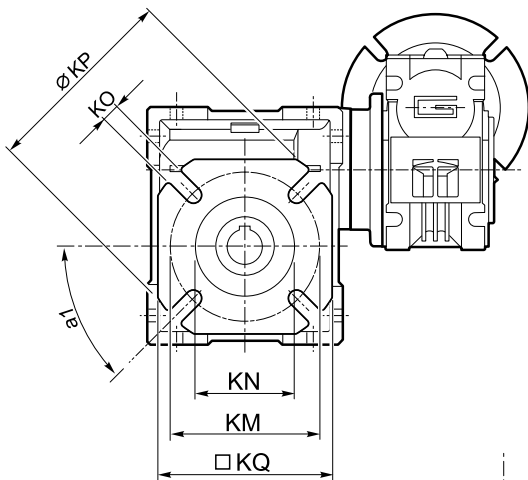

CMM026/026.. F
CMM026/026.. F28
CMM026/026.. F30
CMM026/026.. F30S
CMM026/030.. F..
CMM026/040.. F..

CMM026/026.. F30C
CMM026/026.. F30SC

CMM026/026.. F100

CL026
CL030
CL040

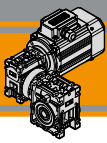

Dimensioni

Dimensions

CMM.. - CMM..F - CMM..FB - CMM..FL																	
	A	C	D _{H8}	E	F	G	G1	H	H1	I	I1	K	L	M	N _{H8}	N1	N2
030/040	70	100	18	121.5	43	55	78	50	40	40	30	60	71	75	60	36.5	29

CMM.. - CMM..F - CMM..FB - CMM..FL														
	O	P	Q	R	R1	S	T	V	Z	KE	a	b	t	Kg
030/040	6.5	87	55	71.5	57	6.5	26	35	122	M6x8(n.4)	45°	6	20.8 (21.8)	3.9

	CMM..F								CMM..FB								CMM..FL								
	a1	KA	KB	KC	KM	KN _{H8}	KO	KP	KQ	KA	KB	KC	KM	KN _{H8}	KO	KP	KQ	KA	KB	KC	KM	KN _{H8}	KO	KP	KQ
030/040	45°	67	7.5	4	80-95	60	9(n.4)	110	95	80	8.5	5	115-125	95	9.5(n.4)	140	112	97	7.5	4.5	80-95	60	9(n.4)	110	95

SMT	BFC	BNV	LFC	LNv
5014	□ 85	□ 80	135.5	108.5
5024			150.5	123.5
5034			175.5	148.5
5044			200.5	173.5
5624	□ 93	□ 87	141	117
5634			151	127
5644			186	162
5654			206	182
6324	□ 105	□ 97	165.5	138.5
6334			180.5	153.5
6344			205.5	178.5

SMM	BFC	BNV	LFC	LNv
5014	□ 85	□ 80	150.5	123.5
5024			175.5	148.5
5034			200.5	173.5
5624			151	127
5634	□ 93	□ 87	186	162
5644			206	182
6324			180.5	153.5
6334	□ 105	□ 97	205.5	178.5

Nota: il condensatore sarà fornito a corredo
Note: the capacitor will be supplied separately

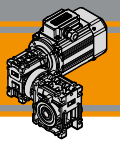

Dimensioni

Dimensions

CMM 030/040 U

S3 servizio duty 30% SMT...TENV SMM... TENV

SMT...TEFC SMM... TEFC

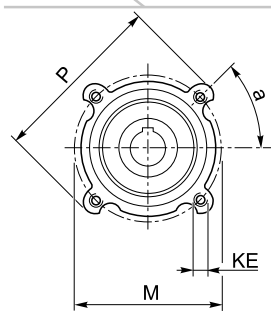
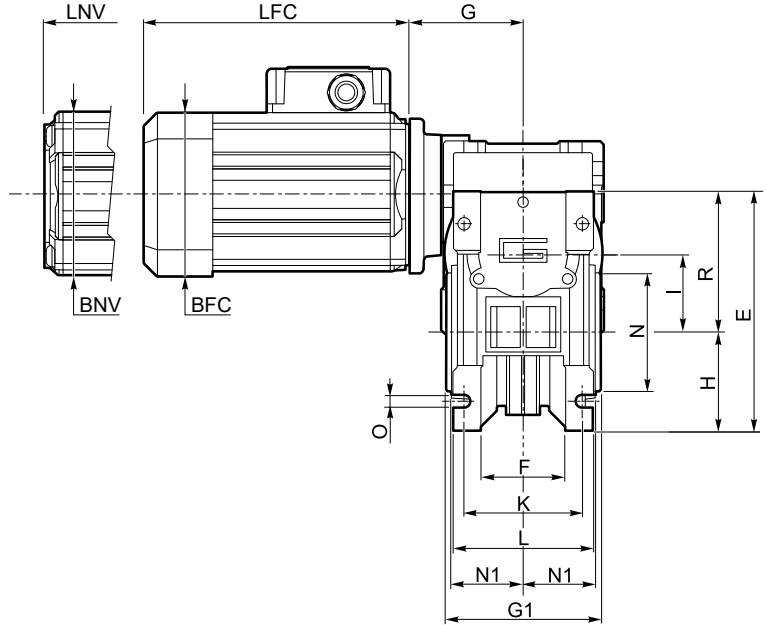
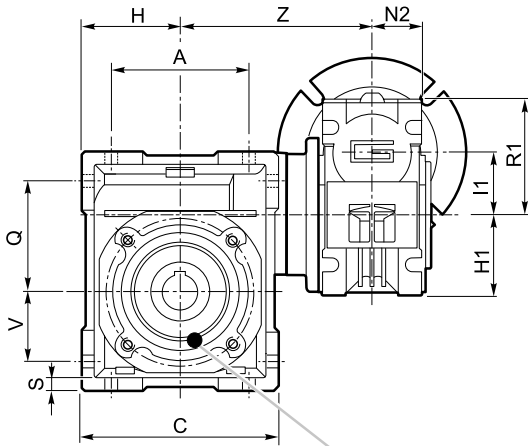

CMM 030/040

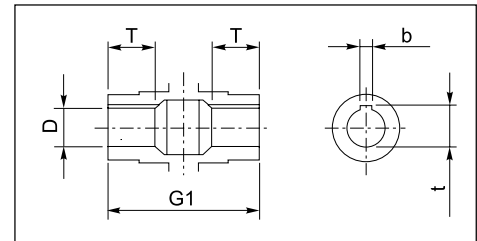

Albero lento cavo / Hollow output shaft

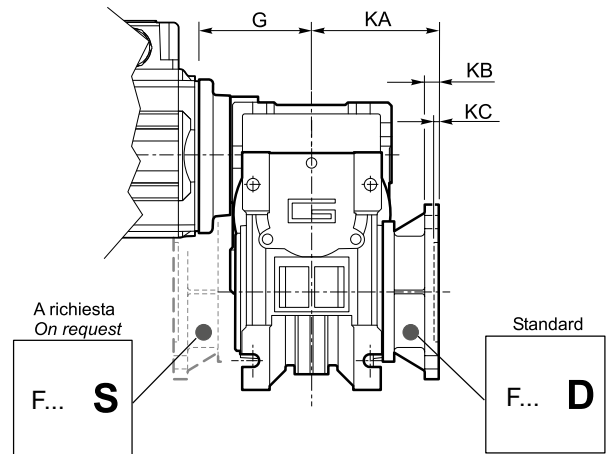
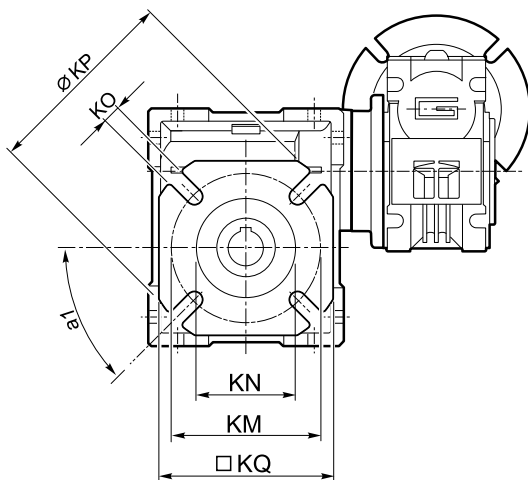

II 9
II 10

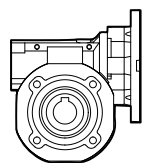

CL030
CL040

AC

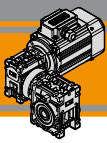

Accessori

Accessories

Albero lento semplice e doppio

Single and double output shaft

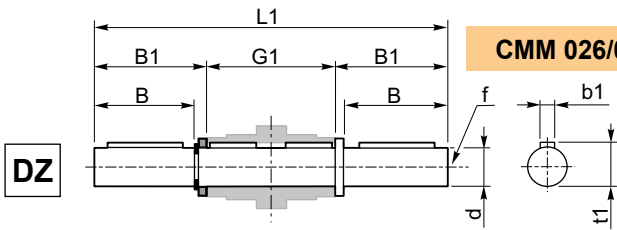

CMM 026/030 - CMM 030/040

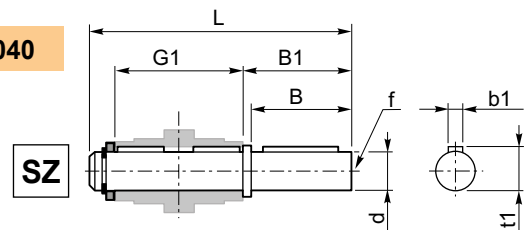

CMM	d _{h7}	B	B1	G1	L	L1	f	b1	t1
026/030	14	30	32.5	63	102	128	M6	5	16
026/040 030/040	18	40	43	78	128	164	M6	6	20.5

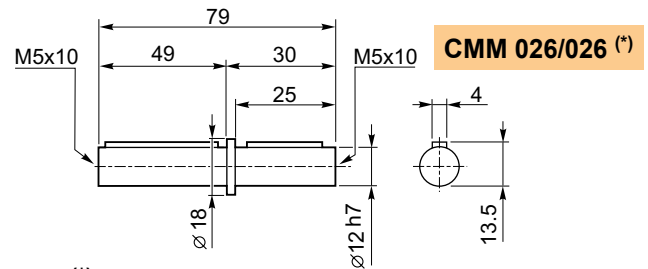

CMM 026/026 (*)

(*)
Nota: disponibile solo per cavo uscita Ø12
Note: available for output hollow shaft Ø12 only

Braccio di reazione

Torque arm

CMM	K1	G	KG	KH	R
026/030	85	14	23	8	15
026/040 030/040	100	14	31	10	18

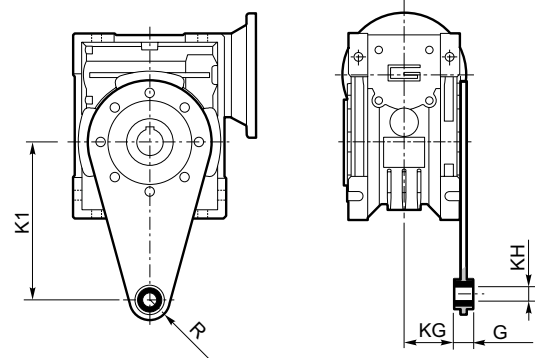

Opzioni

Options

VS1 - VS2 - Vite sporgente / Extended input shaft

SC - Safety cover

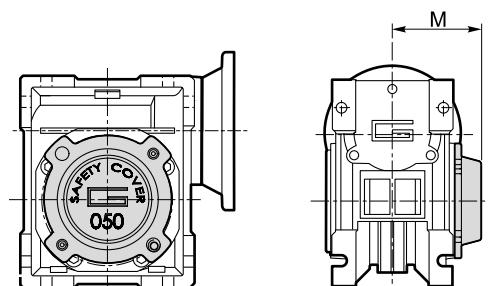
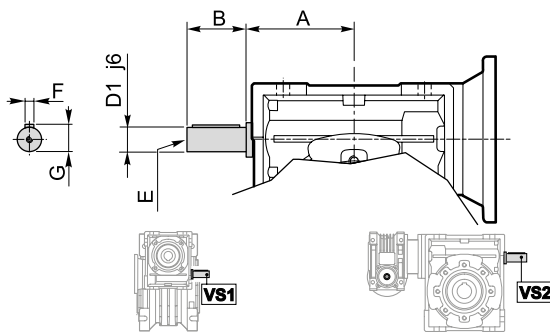

CMM	VS1						VS2					
	A	B	D ₁ j6	E	F	G	A	B	D ₁ j6	E	F	G
026/030	—	—	—	—	—	—	45	20	9	M4	3	10.2
026/040	—	—	—	—	—	—	53	23	11	M5	4	12.5
030/040	45	20	9	M4	3	10.2	53	23	11	M5	4	12.5

M	CM	
	30	40
	47	54.5

Costruito su richiesta
Built on request

MINI  **TECNO**
small but strong

P

AC

Motoriduttori CA epicicloidali AC Planetary gearmotors



MINI  **TECNO** brand of
TRANSTECNO[®]



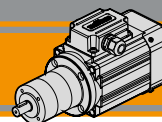

Indice	Index	Pag. Page
Caratteristiche tecniche	<i>Technical features</i>	AG2
Designazione	<i>Classification</i>	AG2
Versioni	<i>Versions</i>	AG2
Simbologia	<i>Symbols</i>	AG3
Lubrificazione	<i>Lubrication</i>	AG3
Carichi radiali	<i>Radial loads</i>	AG3
Rapporti	<i>Ratios</i>	AG3
Dati tecnici	<i>Technical data</i>	AG4
Motori applicabili	<i>IEC Motor adapters</i>	AG7
Dimensioni	<i>Dimensions</i>	AG7

Questa sezione annulla e sostituisce ogni precedente edizione o revisione. Qualora questa sezione non Vi sia giunta in distribuzione controllata, l'aggiornamento dei dati ivi contenuto non è assicurato. **In tal caso la versione più aggiornata è disponibile sul nostro sito internet www.transtecno.com**

This section replaces any previous edition and revision. If you obtained this catalogue other than through controlled distribution channels, the most up to date content is not guaranteed. In this case the latest version is available on our web site www.transtecno.com

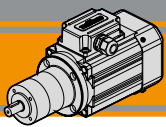

P

Motoriduttori CA epicicloidali
AC planetary gearmotors



Caratteristiche tecniche

Technical features

Le caratteristiche principali dei motoriduttori P sono:

P gearmotors gearmotors have the following main features:

- Costruzione compatta
- Motorizzazioni in corrente alternata monofase e trifase
- Carcassa motore estrusa in alluminio anodizzato nero
- Motore elettrico AC con grado di protezione IP66
- Adatti per servizio continuo ed intermittente
- Disponibili sia nella versione ventilata TEFC (servizio S1) che non ventilata TENV (servizio S3)
- Protezioni termiche per le taglie 56 e 63
- SMT56 e SMT63 adatti al funzionamento con alimentazione da inverter

- *Compact design*
- *AC single phase and three phase motors available*
- *Motor extruded aluminum housing black anodized*
- *AC electric motor in IP66 protection Standard*
- *Suitable for continuous and intermittent operations*
- *Fan cooled TEFC (duty S1) and not ventilated TENV (duty S3) versions available*
- *Thermal protection for motor sizes 56 and 63*
- *SMT56 and SMT63 are suitable for running with inverter*

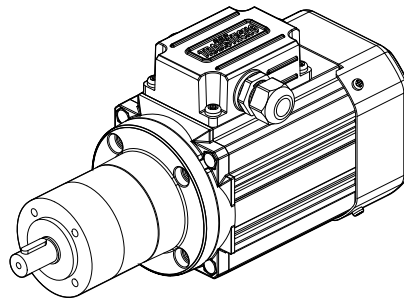

Designazione

Classification

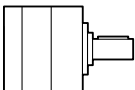
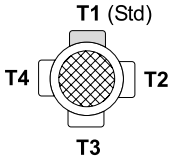
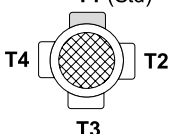
RIDUTTORE / GEARMOTOR								
P	52	2			C	34.97		
Tipo Type	Grandezza Size	Stadi riduttore Gearbox stages			Versione riduttore Gearbox Version	Rapporto Ratio		
P 	52 62	1 2 3			U C80 C90 C105 C120	Vedere tabella See tables		
SMT	56	2	4	B14	230-400 V	50 Hz	TEFC	T1
Tipo Type	Grandezza Size	Indicativo potenza Power coefficient	Poli Poles	Forma costruttiva Version	Tensione Voltage	Frequenza Frequency	Ventilazione Fan cooling	Pos. morsetteria Terminal box pos.
SMT trifase threephase	vedi tabelle see tables	1-2-3-4-5	4	B14	230-400 V	50Hz 60Hz	TEFC TENV	T1 (Std) 
SMM	56	2	4	B14	230 V	50 Hz	TEFC	T1
Tipo Type	Grandezza Size	Indicativo potenza Power coefficient	Poli Poles	Forma costruttiva Version	Tensione Voltage	Frequenza Frequency	Ventilazione Fan cooling	Pos. morsetteria Terminal box pos.
SMM monofase singlephase	vedi tabelle see tables	1-2-3-4	4	B14	230 V	50Hz	TEFC TENV	T1 (Std) 

Versioni

Versions

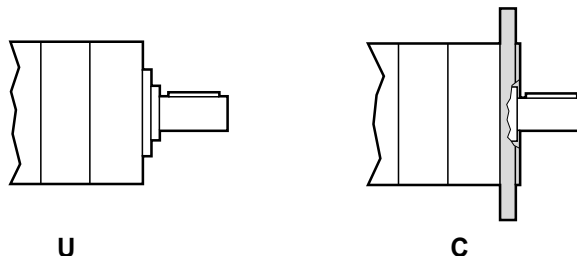

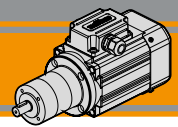

Simbologia

Symbols

n_1 [min ⁻¹]	Velocità in ingresso / <i>Input speed</i>	sf	Fattore di servizio / <i>Service factor</i>
n_2 [min ⁻¹]	Velocità in uscita / <i>Output speed</i>	Rd %	Rendimento dinamico / <i>Dynamic efficiency</i>
i	Rapporto di riduzione / <i>Ratio</i>	A_2 [N]	Carico assiale ammissibile in uscita / <i>Permitted output axial load</i>
P_1 [kW]	Potenza in entrata / <i>Input power</i>	R_2 [N]	Carico radiale ammissibile in uscita / <i>Permitted output radial load</i>
M_2 [Nm]	Coppia in uscita in funzione di P_1 / <i>Output torque referred to P_1</i>		

Lubrificazione

Lubrication

I riduttori epicicloidali sono lubrificati in modo permanente, non richiedono quindi ulteriore manutenzione. Questo gli consente di essere installati praticamente ovunque.

Planetary gearboxes are life-time lubricated with grease, therefore they are maintenance free. They can be installed in any location.

Carichi radiali

Radial loads

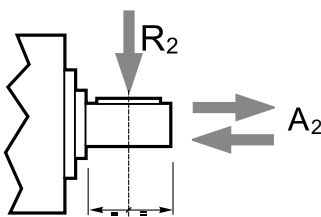

Numero di stadi Stages number	Carichi Radiali R_2 [N] / Radial Load R_2 [N]	
	P52	P62
1	200	240
2	320	360
3	450	520

Numero di stadi Stages number	Carichi Assiali A_2 [N] / Axial Load A_2 [N]	
	P52	P62
1	60	70
2	100	100
3	150	150

Rapporti

Ratios

Numero di stadi Stages number	Per tutte le grandezze di riduttori della serie P For all gearbox sizes of P range	
	Rapporti / Ratios	
1	3.70	
	4.28	
	5.18	
2	6.75	
	13.73	
	15.88	
	18.36	
	19.20	
	22.20	
	25.01	
	26.85	
	28.93	
	34.97	
45.56		
3	50.89	
	58.85	
	68.06	
	71.16	
	78.71	
	92.70	
	95.17	
	99.50	
	107.20	
	115.07	
	123.97	
	129.62	
	139.13	
	149.90	
	168.84	
181.24		
195.26		
236.09		
307.54		

Rapporti preferenziali per le taglie P52, P62.
Preferred ratios for P52, P62.

Disponibile a 4 stadi con rapporti fino a 2076
Available 4 stages with ratio up to 2076

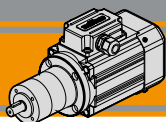
**P****Motoriduttori CA epicicloidali
AC planetary gearmotors****Dati tecnici****Technical data**

P_1 [kW]	n_2 [min ⁻¹]	M_2 [Nm]	sf	i			P_1 [kW]	n_2 [min ⁻¹]	M_2 [Nm]	sf	i					
0.04							0.06									
SMT5014	378	0.8	6.3	3.7	521	B14	SMT5024	378	1	4.2	3.7	521	B14			
SMM5014	327	0.9	5.4	4.28			SMM5024	327	1	3.6	4.28			B14		
(1400 min ⁻¹)	270	1.1	4.5	5.18			B14	(1400 min ⁻¹)	270	2	3.0			5.18	B14	
	207	1.5	3.4	6.75			B14		207	2	2.3			6.75	B14	
	102	3	5.4	13.73	522	B14	102	4	3.6	13.73	522	B14				
	88	3	4.7	15.88			B14									
	76	4	4.0	18.36			B14									
	73	4	3.9	19.2			B14									
	63	5	3.3	22.2			B14									
	56	5	3.0	25.01			B14									
	52	5	2.8	26.85			B14									
	48	6	2.6	28.93			B14									
	40	7	2.1	34.97			B14									
	31	9	1.6	45.56			B14									
	28	10	3.3	50.89			523	B14	28	15			2.2	50.89	523	B14
	24	11	2.8	58.85					B14							
	21	13	2.4	68.06					B14							
	20	14	2.3	71.16					B14							
	18	15	2.1	78.71	B14											
	15	18	1.8	92.7	B14											
	15	18	1.7	95.17	B14											
	14	19	1.7	99.5	B14											
	13	20	1.5	107.2	B14											
	12	22	1.4	115.07	B14											
	11	24	1.3	123.97	B14											
	11	25	1.3	129.62	B14											
	10	27	1.2	139.13	B14											
	9.3	29	1.1	149.9	B14											
	8.3	32	1.0	168.84	B14											
	7.7	35	0.9	181.24	B14											
	7.2	37	0.8	195.26	B14											
	5.9	45	0.7	236.09	B14											
	4.6	45	0.7	307.54	B14											
	56	5	6.2	25.01	622	B14	56	8	4.1	25.01	622	B14				
	52	5	5.8	26.85			B14									
	48	6	5.3	28.93			B14									
	40	7	4.4	34.97			B14									
	31	9	3.4	45.56	B14											
	28	10	6.5	50.89	623	B14	28	15	4.3	50.89	623	B14				
	24	11	5.6	58.85			B14									
	21	13	4.9	68.06			B14									
	20	14	4.7	71.16			B14									
	18	15	4.2	78.71			B14									
	15	18	3.6	92.7			B14									
	15	18	3.5	95.17			B14									
	14	19	3.3	99.5			B14									
	13	20	3.1	107.2			B14									
	12	22	2.9	115.07			B14									
	11	24	2.7	123.97			B14									
	11	25	2.6	129.62			B14									
	10	27	2.4	139.13			B14									
	9.3	29	2.2	149.9			B14									
	8.3	32	2.0	168.84	B14											
	7.7	35	1.8	181.24	B14											
	7.2	37	1.7	195.26	B14											
	5.9	45	1.4	236.09	B14											
	4.6	59	1.1	307.54	B14											

NOTA
Per sf=0.7 verificare che la coppia utilizzata non ecceda il valore M2 indicato.

NOTE
For sf=0.7 check that the duty torque does not exceed the value M2

Motoriduttori preferenziali / Preferred gearmotors

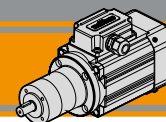
Dati tecnici
Technical data

P_1 [kW]	n_2 [min ⁻¹]	M_2 [Nm]	sf	i			P_1 [kW]	n_2 [min ⁻¹]	M_2 [Nm]	sf	i		
0.09							0.12						
SMT5034	378	2	2.8	3.7	521	B14	SMT5044	378	2	2.1	3.7	521	B14
SMM5034	327	2	2.4	4.28		B14	SMT5634	327	3	1.8	4.28		B14
SMT5624	270	3	2.0	5.18		B14	SMM5634	270	3	1.5	5.18		B14
SMM5624 (1400 min ⁻¹)	207	3	1.5	6.75		B14	(1400 min ⁻¹)	207	4	1.1	6.75		B14
	102	6	2.4	13.73	522	B14	102	8	1.8	13.73	522	B14	
	88	7	2.1	15.88		B14	88	10	1.6	15.88		B14	
	76	8	1.8	18.36		B14	76	11	1.3	18.36		B14	
	73	9	1.7	19.2		B14	73	12	1.3	19.2		B14	
	63	10	1.5	22.2		B14	63	14	1.1	22.2		B14	
	56	12	1.3	25.01		B14	56	15	1.0	25.01		B14	
	52	12	1.2	26.85		B14	52	16	0.9	26.85		B14	
	48	13	1.1	28.93		B14	48	18	0.9	28.93		B14	
	40	16	0.9	34.97		B14	40	22	0.7	34.97		B14	
	31	21	0.7	45.56		B14	31	22	0.7	45.56		B14	
	28	22	1.4	50.89	523	B14	28	29	1.1	50.89	523	B14	
	24	25	1.3	58.85		B14	24	34	0.9	58.85		B14	
	21	29	1.1	68.06		B14	21	39	0.8	68.06		B14	
	20	31	1.0	71.16		B14	20	41	0.8	71.16		B14	
	18	34	0.9	78.71		B14	18	45	0.7	78.71		B14	
	15	40	0.8	92.7		B14	15	45	0.7	92.7		B14	
	15	41	0.8	95.17		B14	15	45	0.7	95.17		B14	
	14	45	0.7	99.5		B14	14	45	0.7	99.5		B14	
	13	45	0.7	107.2		B14	13	45	0.7	107.2		B14	
	12	45	0.7	115.07		B14	12	45	0.7	115.07		B14	
	11	45	0.7	123.97	B14	11	45	0.7	123.97	B14			
	11	45	0.7	129.62	B14	11	45	0.7	129.62	B14			
	10	45	0.7	139.13	B14	10	45	0.7	139.13	B14			
	56	12	2.7	25.01	622	B14	378	2	4.2	3.7	621	B14	
	52	12	2.6	26.85		B14	327	3	3.6	4.28		B14	
	48	13	2.4	28.93		B14	270	3	3.0	5.18		B14	
	40	16	2.0	34.97		B14	207	4	2.3	6.75		B14	
	31	21	1.5	45.56	B14								
	28	22	2.9	50.89	623	B14	102	8	3.8	13.73	622	B14	
	24	25	2.5	58.85		B14	88	10	3.2	15.88		B14	
	21	29	2.2	68.06		B14	76	11	2.8	18.36		B14	
	20	31	2.1	71.16		B14	73	12	2.7	19.2		B14	
	18	34	1.9	78.71		B14	63	14	2.3	22.2		B14	
	15	40	1.6	92.7		B14	56	15	2.1	25.01		B14	
	15	41	1.5	95.17		B14	52	16	1.9	26.85		B14	
	14	43	1.5	99.5		B14	48	18	1.8	28.93		B14	
	13	46	1.4	107.2		B14	40	21	1.5	34.97		B14	
	12	49	1.3	115.07		B14	31	28	1.1	45.56		B14	
	11	53	1.2	123.97	B14								
	11	56	1.1	129.62	B14	28	29	2.2	50.89	623	B14		
	10	60	1.1	139.13	B14	24	34	1.9	58.85		B14		
	9.3	64	1.0	149.9	B14	21	39	1.6	68.06		B14		
	8.3	73	0.9	168.84	B14	20	41	1.6	71.16		B14		
	7.7	78	0.8	181.24	B14	18	45	1.4	78.71		B14		
	7.2	84	0.8	195.26	B14	15	53	1.2	92.7		B14		
	5.9	90	0.7	236.09	B14	15	55	1.2	95.17		B14		
	4.6	90	0.7	307.54	B14	14	57	1.1	99.5		B14		
						13	61	1.0	107.2		B14		
						12	66	1.0	115.07		B14		
						11	71	0.9	123.97	B14			
						11	74	0.9	129.62	B14			
						10	80	0.8	139.13	B14			
						9.3	90	0.7	149.9	B14			
						8.3	90	0.7	168.84	B14			
						7.7	90	0.7	181.24	B14			
						7.2	90	0.7	195.26	B14			

NOTA
Per sf=0.7 verificare che la coppia utilizzata non ecceda il valore M2 indicato.

NOTE
For sf=0.7 check that the duty torque does not exceed the value M2

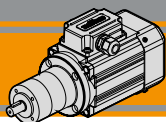
**P****Motoriduttori CA epicicloidali
AC planetary gearmotors****Dati tecnici****Technical data**

P_1 [kW]	n_2 [min ⁻¹]	M_2 [Nm]	sf	i			P_1 [kW]	n_2 [min ⁻¹]	M_2 [Nm]	sf	i					
0.18							0.25									
SMT5644	378	4	1.4	3.7	521	B14	SMT5654	378	4	1.4	3.7	521	B14			
SMM5644	327	4	1.2	4.28			SMT6334	327	4	1.2	4.28					
SMT6324	270	5	1.0	5.18			SMM6334	270	5	1.0	5.18					
SMM6324	207	7	0.8	6.75			(1400 min ⁻¹)	207	7	0.8	6.75					
(1400 min ⁻¹)	102	13	1.2	13.73	522	B14	102	18	0.9	13.73	522	B14				
	88	15	1.0	15.88			88	20	0.7	15.88						
	76	17	0.9	18.36			76	22	0.7	18.36						
	73	18	0.9	19.2			73	22	0.7	19.2						
	63	22	0.7	22.2	523	B14		378	5	2.0	3.7	621	B14			
	56	22	0.7	25.01			327	6	1.7	4.28						
	52	22	0.7	26.85			270	7	1.4	5.18						
	48	22	0.7	28.93			207	9	1.1	6.75						
	28	45	0.7	50.89	621	B14		102	18	1.8	13.73	622	B14			
	24	45	0.7	58.85			88	20	1.6	15.88						
	21	45	0.7	68.06			76	23	1.3	18.36						
	20	45	0.7	71.16			73	25	1.3	19.2						
	378	4	2.8	3.7	622	B14	63	28	1.1	22.2	63	28	1.1	22.2		
	327	4	2.4	4.28			56	32	1.0	25.01	56	32	1.0	25.01		
	270	5	2.0	5.18			52	34	0.9	26.85	52	34	0.9	26.85		
	207	7	1.5	6.75			48	37	0.9	28.93	48	37	0.9	28.93		
	102	13	2.5	13.73	623	B14	40	45	0.7	34.97	40	45	0.7	34.97		
	88	15	2.2	15.88			31	45	0.7	45.56	31	45	0.7	45.56		
	76	17	1.9	18.36			28	61	1.0	50.89	28	61	1.0	50.89		
	73	18	1.8	19.2			24	70	0.9	58.85	24	70	0.9	58.85		
	63	20	1.5	22.2	623	B14	21	81	0.8	68.06	21	81	0.8	68.06		
	56	23	1.4	25.01			20	85	0.7	71.16	20	85	0.7	71.16		
	52	25	1.3	26.85			18	90	0.7	78.71	18	90	0.7	78.71		
	48	27	1.2	28.93			15	90	0.7	92.7	15	90	0.7	92.7		
	40	32	1.0	34.97	623	B14	15	90	0.7	95.17	15	90	0.7	95.17		
	31	42	0.8	45.56			14	90	0.7	99.5	14	90	0.7	99.5		
	28	44	1.4	50.89												
	24	51	1.3	58.85												
	21	58	1.1	68.06	621	B14	378	7	1.4	3.7	378	7	1.4	3.7		
	20	61	1.0	71.16			327	9	1.2	4.28	327	9	1.2	4.28		
	18	68	0.9	78.71			270	10	1.0	5.18	270	10	1.0	5.18		
	15	80	0.8	92.7			207	14	0.7	6.75	207	14	0.7	6.75		
	15	82	0.8	95.17	622	B14		102	26	1.2	13.73		102	26	1.2	13.73
	14	86	0.7	99.5			88	30	1.1	15.88	88	30	1.1	15.88		
	13	90	0.7	107.2			76	35	0.9	18.36	76	35	0.9	18.36		
	12	90	0.7	115.07			73	36	0.9	19.2	73	36	0.9	19.2		
	11	90	0.7	123.97	623	B14	63	42	0.8	22.2	63	42	0.8	22.2		
	11	90	0.7	129.62			56	45	0.7	25.01	56	45	0.7	25.01		
	10	90	0.7	139.13			52	45	0.7	26.85	52	45	0.7	26.85		
							48	45	0.7	28.93	48	45	0.7	28.93		
					623	B14	28	90	0.7	50.89	28	90	0.7	50.89		
							24	90	0.7	58.85	24	90	0.7	58.85		
							21	90	0.7	68.06	21	90	0.7	68.06		
							20	90	0.7	71.16	20	90	0.7	71.16		

NOTA

Per sf=0.7 verificare che la coppia utilizzata non ecceda il valore M2 indicato.

NOTE

For sf=0.7 check that the duty torque does not exceed the value M2

Motoriduttori preferenziali / Preferred gearmotors

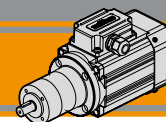
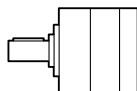
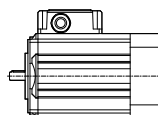
Motori applicabili
IEC Motor adapters

		SMT		SMM		SMT		SMM	
		5014	5624	5014	5624	6324		6324	
		5024	5634	5024	5634	6334		6334	
		5034	5644	5034	5644	6344			
		5044	5654						
P	52...								
	62...								

 Flangia di combainazione
 Combination flange

Dimensioni
Dimensions
P52 ... U
S3 servizio 30%
 duty

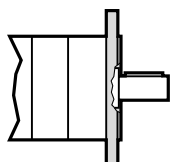
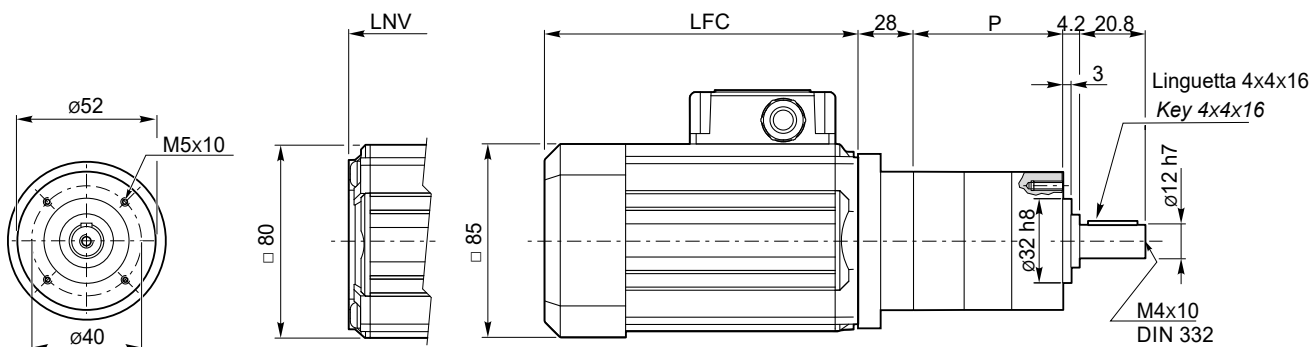
SMT50...TENV
SMM50... TENV
SMT50...TEFC
SMM50... TEFC

P52...C

Tipo Type	Numero di stadi Stages number	P
P52...	1	46
	2	60
	3	74

SMT	LFC	LNV	Kg	
5014	135.5	108.5	3.4	
5024	150.5	123.5	3.8	
5034	175.5	148.5	4.6	
5044	200.5	173.5	5.3	

SMM	LFC	LNV	Kg	
5014	150.5	123.5	3.8	
5024	175.5	148.5	4.6	
5034	200.5	173.5	5.3	

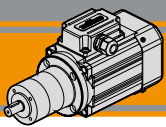
Nota: il condensatore sarà fornito a corredo
Note: the capacitor will be supplied separately



P

Dimensioni

Dimensions

P52 ... U

S3 servizio 30%
duty

SMT56...TENV
SMM56... TENV

SMT56...TEFC
SMM56... TEFC

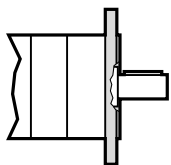
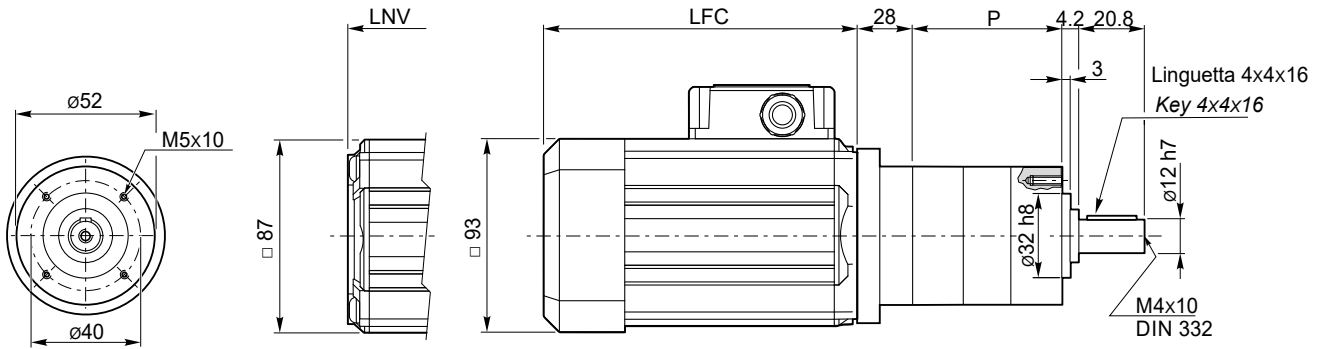

AG10

P52...C

Tipo Type	Numero di stadi Stages number	P
P52...	1	46
	2	60
	3	74

SMT	LFC	LNV	Kg	
5624	141	117	3.9	
5634	151	127	4.3	
5644	186	162	5.5	
5654	206	182	6.2	

SMM	LFC	LNV	Kg	
5624	151	127	4.2	
5634	171	147	4.8	
5644	206	182	6.1	

Nota: il condensatore sarà fornito a corredo
Note: the capacitor will be supplied separately

P62 ... U

S3 servizio 30%
duty

SMT50...TENV
SMM50... TENV

SMT50...TEFC
SMM50... TEFC

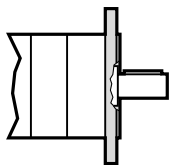
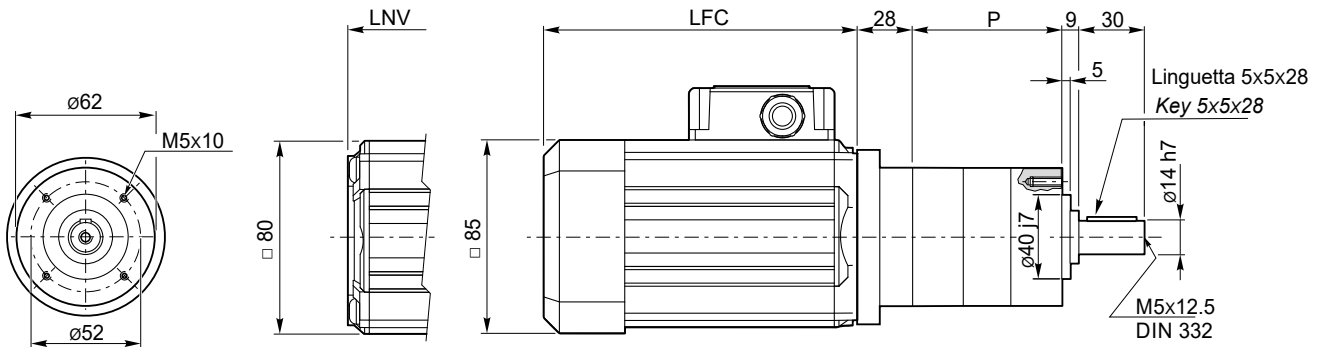

AG10

P62...C

Tipo Type	Numero di stadi Stages number	P
P62...	1	46
	2	62
	3	78

SMT	LFC	LNV	Kg	
5014	135.5	108.5	3.9	
5024	150.5	123.5	4.3	
5034	175.5	148.5	5.1	
5044	200.5	173.5	5.8	

SMM	LFC	LNV	Kg	
5014	150.5	123.5	4.3	
5024	175.5	148.5	5.1	
5034	200.5	173.5	5.8	

Nota: il condensatore sarà fornito a corredo
Note: the capacitor will be supplied separately

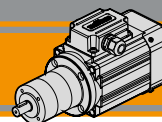
Dimensioni
Dimensions
P62 ... U
S3 servizio duty 30%

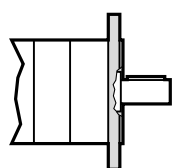
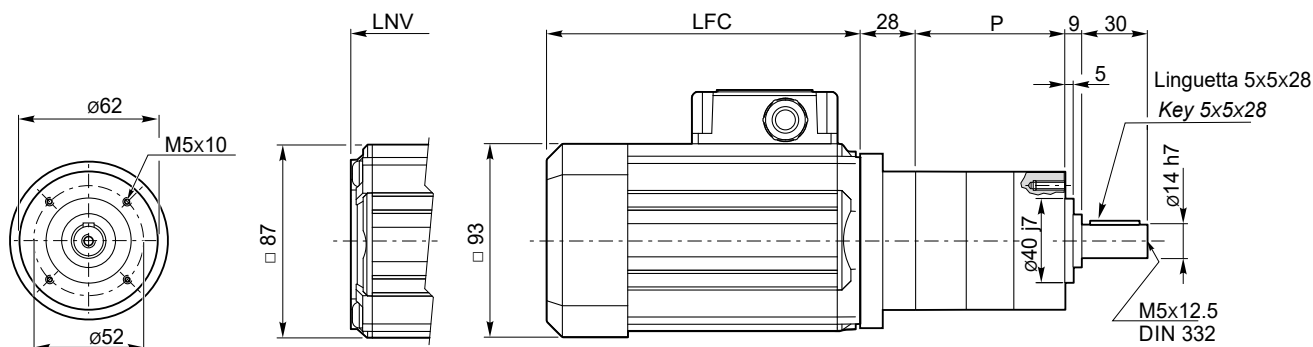
SMT56...TENV
SMM56... TENV
SMT56...TEFC
SMM56... TEFC

P62...C

Tipo Type	Numero di stadi Stages number	P
P62...	1	46
	2	62
	3	78

SMT	LFC	LNV	Kg	
5624	141	117	4.4	
5634	151	127	4.8	
5644	186	162	6	
5654	206	182	6.7	

SMM	LFC	LNV	Kg	
5624	151	127	4.7	
5634	171	147	5.3	
5644	206	182	6.6	

Nota: il condensatore sarà fornito a corredo
Note: the capacitor will be supplied separately

P62 ... U
S3 servizio duty 30%

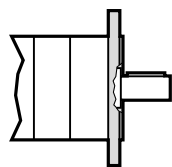
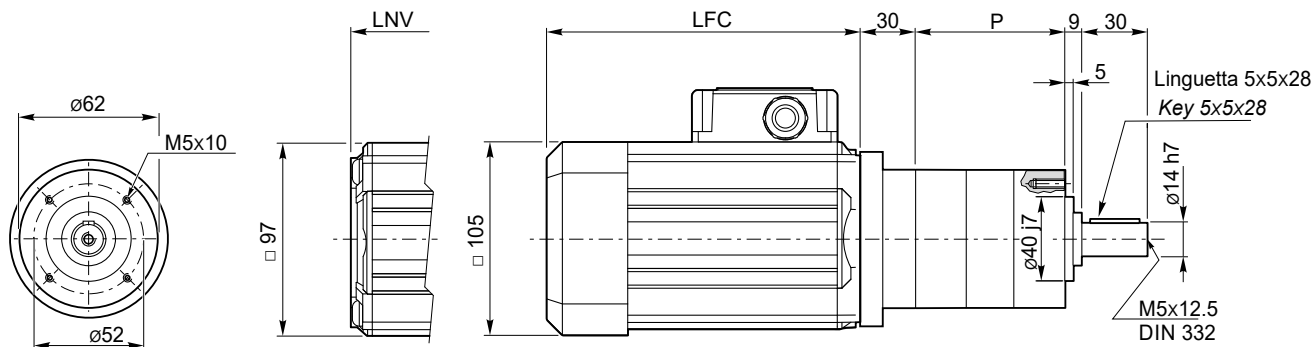
SMT63...TENV
SMM63... TENV
SMT63...TEFC
SMM63... TEFC

P62...C

Tipo Type	Numero di stadi Stages number	P
P62...	1	46
	2	62
	3	78

SMT	LFC	LNV	Kg	
6324	165.5	138.5	5.9	
6334	180.5	153.5	6.6	
6344	205.5	178.5	7.8	

SMM	LFC	LNV	Kg	
6324	180.5	153.5	6.7	
6334	205.5	178.5	7.9	

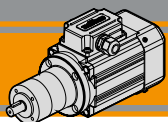
Nota: il condensatore sarà fornito a corredo
Note: the capacitor will be supplied separately



P

Motoriduttori CA epicicloidali
AC planetary gearmotors

MINI TECNO

Dimensioni

Dimensions

P.../... C... Flange uscita / Output flanges

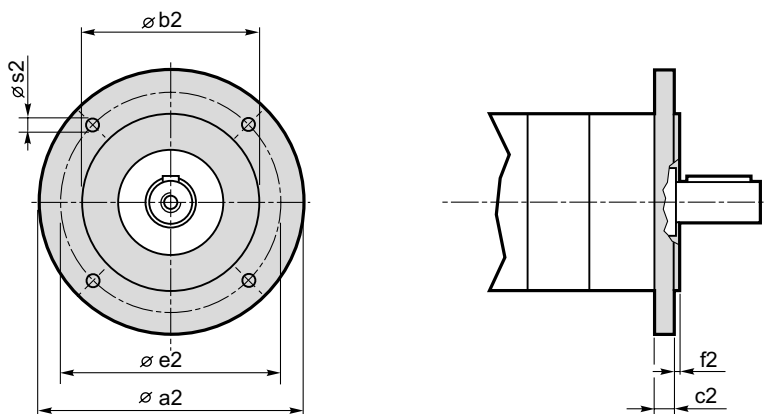

Dimensioni / Dimensions							
P	a2	b2	c2	e2	f2	s2	Flangia uscita Output flange
52	80	50 j7	9	65	2.5	M5	C80
	90	60 j7	9	75	2.5	5.5	C90
	105	70 j7	9	85	2.5	6.5	C105
	120	80 j7	9	100	3.0	6.5	C120
62	80	50 j7	9	65	2.5	M5	C80
	90	60 j7	9	75	2.5	5.5	C90
	105	70 j7	9	85	2.5	6.5	C105
	120	80 j7	9	100	3.0	6.5	C120

MINI 
TECNO
small but strong

WMP

AC

Motoriduttori CA combinati
AC Double reduction gearmotors

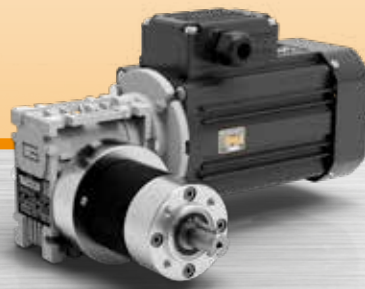

MINI 
TECNO brand of
TRANSTECNO[®]



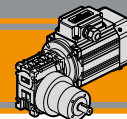

Indice	Index	Pag. Page
Caratteristiche tecniche	<i>Technical features</i>	AH2
Designazione	<i>Classification</i>	AH2
Versioni	<i>Versions</i>	AH2
Simbologia	<i>Symbols</i>	AH3
Lubrificazione	<i>Lubrication</i>	AH3
Carichi radiali	<i>Radial loads</i>	AH3
Rapporti	<i>Ratios</i>	AH3
Dati tecnici	<i>Technical data</i>	AH4
Motori applicabili	<i>IEC Motor adapters</i>	AH5
Dimensioni	<i>Dimensions</i>	AH5

Questa sezione annulla e sostituisce ogni precedente edizione o revisione. Qualora questa sezione non Vi sia giunta in distribuzione controllata, l'aggiornamento dei dati ivi contenuto non è assicurato. **In tal caso la versione più aggiornata è disponibile sul nostro sito internet www.transtecno.com**

This section replaces any previous edition and revision. If you obtained this catalogue other than through controlled distribution channels, the most up to date content is not guaranteed. In this case the latest version is available on our web site www.transtecno.com

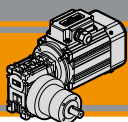

Caratteristiche tecniche

Technical features

Le caratteristiche principali dei motoriduttori WMP sono:

WMP gearmotors gearmotors have the following main features:

- Costruzione compatta
- Motorizzazioni in corrente alternata monofase e trifase
- Carcassa motore estrusa in alluminio anodizzato nero
- Motore elettrico AC con grado di protezione IP66
- Adatti per servizio continuo ed intermittente
- Disponibili sia nella versione ventilata TEFC (servizio S1) che non ventilata TENV (servizio S3)
- Protezioni termiche per le taglie 56 e 63
- SMT56 e SMT63 adatti al funzionamento con alimentazione da inverter

- Compact design
- AC single phase and three phase motors available
- Motor extruded aluminum housing black anodized
- AC electric motor in IP66 protection Standard
- Suitable for continuous and intermittent operations
- Fan cooled TEFC (duty S1) and not ventilated TENV (duty S3) versions available
- Thermal protection for motor sizes 56 and 63
- SMT56 and SMT63 are suitable for running with inverter

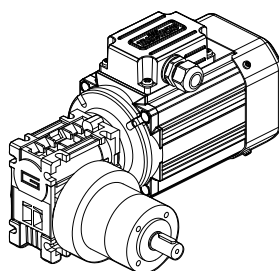

Designazione

Classification

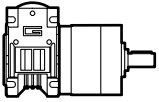
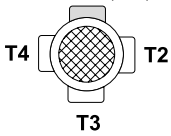
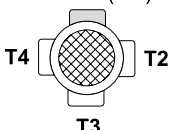
RIDUTTORE / GEARMOTOR								
WMP	026/52	2	C	202.5	56 B14			
Tipo Type	Grandezza Size	Numero stadi epicicloidale Planetary stages number	Versione riduttore Gearbox Version	Rapporto Ratio	IEC  56 B14			
WMP 	026/52 026/62	1 2 3	US UD CS80...120 CD80...120	Vedere tabella See tables				
SMT	56	2	4	B14	230-400 V	50 Hz	TEFC	T1
Tipo Type	Grandezza Size	Indicativo potenza Power coefficient	Poli Poles	Forma costruttiva Version	Tensione Voltage	Frequenza Frequency	Ventilazione Fan cooling	Pos. morsetteria Terminal box pos.
SMT trifase threephase	vedi tabelle see tables	1-2-3-4-5	4	B14	230-400 V	50Hz 60Hz	TEFC TENV	T1 (Std) 
SMM	56	2	4	B14	230 V	50 Hz	TEFC	T1
Tipo Type	Grandezza Size	Indicativo potenza Power coefficient	Poli Poles	Forma costruttiva Version	Tensione Voltage	Frequenza Frequency	Ventilazione Fan cooling	Pos. morsetteria Terminal box pos.
SMM monofase singlephase	vedi tabelle see tables	1-2-3-4	4	B14	230 V	50Hz	TEFC TENV	T1 (Std) 

Versioni

Versions

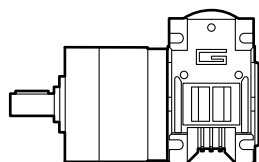

US

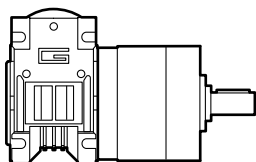

UD

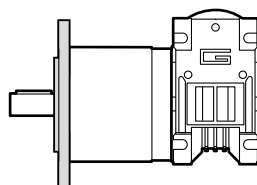

CS

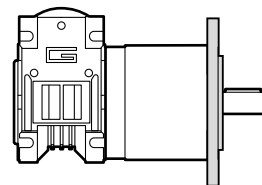

CD

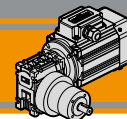

Simbologia

Symbols

n_1 [min ⁻¹]	Velocità in ingresso / <i>Input speed</i>	sf	Fattore di servizio / <i>Service factor</i>
n_2 [min ⁻¹]	Velocità in uscita / <i>Output speed</i>	Rd %	Rendimento dinamico / <i>Dynamic efficiency</i>
i	Rapporto di riduzione / <i>Ratio</i>	A_2 [N]	Carico assiale ammissibile in uscita / <i>Permitted output axial load</i>
P_1 [kW]	Potenza in entrata / <i>Input power</i>	R_2 [N]	Carico radiale ammissibile in uscita / <i>Permitted output radial load</i>
M_2 [Nm]	Coppia in uscita in funzione di P_1 / <i>Output torque referred to P_1</i>		

Lubrificazione

Lubrication

I riduttori epicicloidali sono lubrificati in modo permanente, non richiedono quindi ulteriore manutenzione. Questo gli consente di essere installati praticamente ovunque.

Planetary gearboxes are life-time lubricated with grease, therefore they are maintenance free. They can be installed in any location.

Carichi radiali

Radial loads

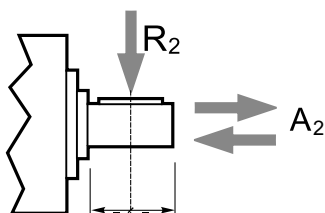

Numero di stadi <i>Stages number</i>	Carichi Radiali R_2 [N] / <i>Radial Load R_2 [N]</i>	
	P52	P62
1	200	240
2	320	360
3	450	520

Numero di stadi <i>Stages number</i>	Carichi Assiali A_2 [N] / <i>Axial Load A_2 [N]</i>	
	P52	P62
1	60	70
2	100	100
3	150	150

Rapporti

Ratios

Motoriduttore <i>Gearmotor</i>	Numero stadi epicicloidale <i>Planetary stages number</i>	Rapporto epicicloidale <i>Planetary ratio</i>	Rapporto vite senza fine <i>Wormgearbox ratio</i>	Rapporto finale <i>Total ratio</i>
WMP 026/052 WMP 026/062	1	6.75	10	67.5
			15	101.3
			20	135
			30	202.5
			40	270
			50	337.5
	2	25.01	10	250.1
			15	375.15
			20	500.2
			30	750.3
			40	1000.4
			50	1250.5
			60	1500.6
		45.56	60	2734

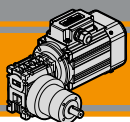

Dati tecnici

Technical data

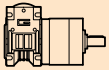
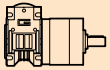
P_1 [kW]	n_2 [min ⁻¹]	M_2 [Nm]	sf	i		Versione motore Motor version	P_1 [kW]	n_2 [min ⁻¹]	M_2 [Nm]	sf	i		Versione motore Motor version			
0.04							0.06									
SMT5014	20.7	12.2	2.0	67.5	026/521	B14	SMT5024	20.7	18.3	1.4	67.5	026/521	B14			
SMM5014	13.8	17.2	1.4	101.3			SMM5024	13.8	25.0	1.0	101.3					
(1400 min ⁻¹)	10.4	21.8	1.1	135			(1400 min ⁻¹)	10.4	25.0	1.0	135					
	6.9	25.0	1.0	202.5												
	5.2	25.0	1.0	270												
	4.1	25.0	1.0	337.5	026/522	B14		20.7	18.3	2.2	67.5	026/621	B14			
	3.5	25.0	1.0	405					13.8	25.9	1.5			101.3		
									10.4	32.7	1.2			135		
	5.6	25.0	1.0	250.1					6.9	40.0	1.0			202.5		
	3.7	25.0	1.0	375.15					5.2	40.0	1.0			270		
	2.8	25.0	1.0	500.2												
	1.9	25.0	1.0	750.3					5.6	50.0	1.0			250.1		
	1.4	25.0	1.0	1000.4												
	1.1	25.0	1.0	1250.5			026/621	B14							026/622	B14
	0.9	25.0	1.0	1500.6												
	0.5	25.0	1.0	2734												
	20.7	12.2	3.3	67.5												
	13.8	17.2	2.3	101.3												
	10.4	21.8	1.8	135												
	6.9	29.2	1.4	202.5												
	5.2	36.0	1.1	270												
	4.1	40.0	1.0	337.5												
	3.5	40.0	1.0	405												
	5.6	42.5	1.2	250.1	026/622	B14					026/621	B14				
	3.7	50.0	1.0	375.15												
	2.8	50.0	1.0	500.2												
	1.9	50.0	1.0	750.3												
	1.4	50.0	1.0	1000.4												
	1.1	50.0	1.0	1250.5												
	0.9	50.0	1.0	1500.6												
	0.5	50.0	1.0	2734												
0.09							0.12									
SMT5034	20.7	25.0	1.0	67.5	026/521	B14	SMT5044	20.7	36.7	1.1	67.5	026/621	B14			
SMM5034							SMM5034									
(1400 min ⁻¹)							(1400 min ⁻¹)									
					026/621	B14	SMT5624	20.7	27.5	1.5	67.5	026/621	B14			
							SMM5624	13.8	38.8	1.0	101.3					
							(1400 min ⁻¹)	10.4	40.0	1.0	135					
0.18							0.18									
							SMT5644	20.7	40.0	1.0	67.5	026/621	B14			
							SMM5644									
							SMT6324									
							SMM6324									
							(1400 min ⁻¹)									

N.B.
Verificare sempre che la coppia M2 utilizzata non ecceda il valore indicato nelle caselle in grigio.

N.B.
Please check that the output torque M2 does not exceed the value in the grey areas.

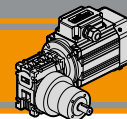

Motori applicabili

IEC Motor adapters

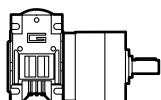
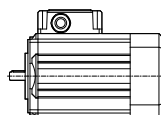

		SMT		SMM	
		5014	5624	5014	5624
		5024	5634	5024	5634
		5034	5644	5034	5644
		5044	5654		
WMP	026/52	67.5 - 2734			
	026/62	67.5 - 2734			

67.5 - 2734

Rapporti di riduzione i
Ratio i

Dimensioni

Dimensions

WMP 026/521
WMP 026/522

SMT50...TEFC
SMM50... TEFC

SMT50...TENV
SMM50... TENV

S3 servizio 30%
duty

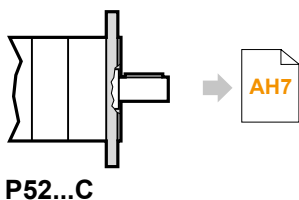
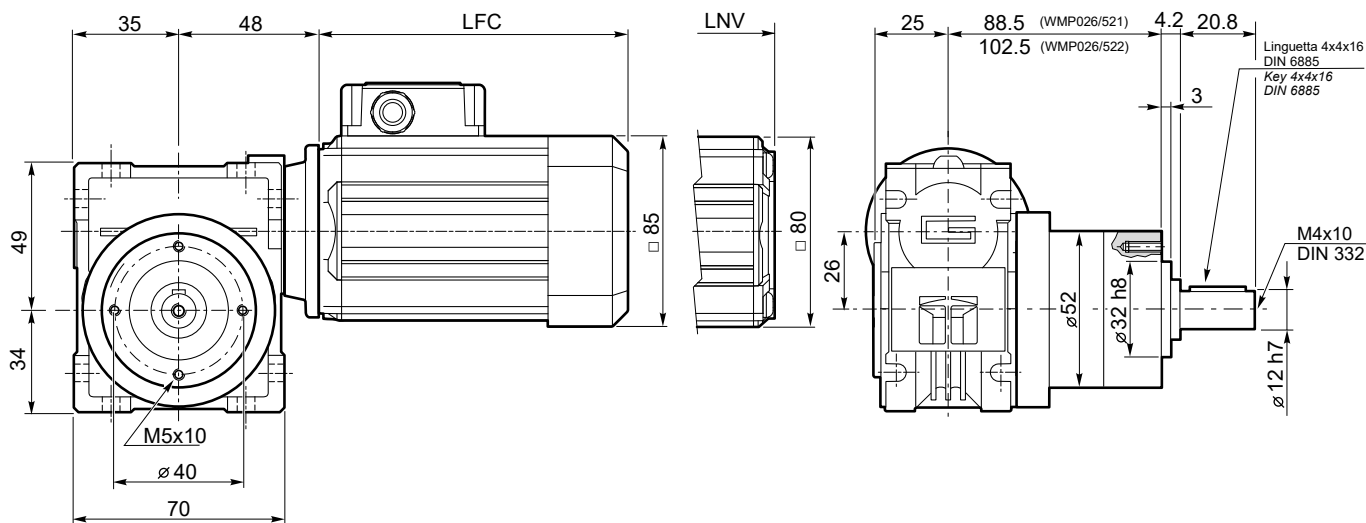

SMT	LFC	LNV	Kg	
5014	135.5	108.5	4.1	
5024	150.5	123.5	4.5	
5034	175.5	148.5	5.3	
5044	200.5	173.5	6	

SMM	LFC	LNV	Kg	
5014	150.5	123.5	4.5	
5024	175.5	148.5	5.3	
5034	200.5	173.5	6	

Nota: il condensatore sarà fornito a corredo
Note: the capacitor will be supplied separately

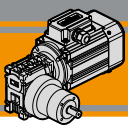

Dimensioni

Dimensions

WMP 026/521
WMP 026/522

SMT56...TEFC
SMM56... TEFC

SMT56...TENV
SMM56... TENV **S3** servizio **30%**
duty

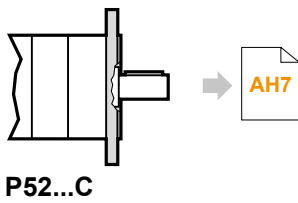
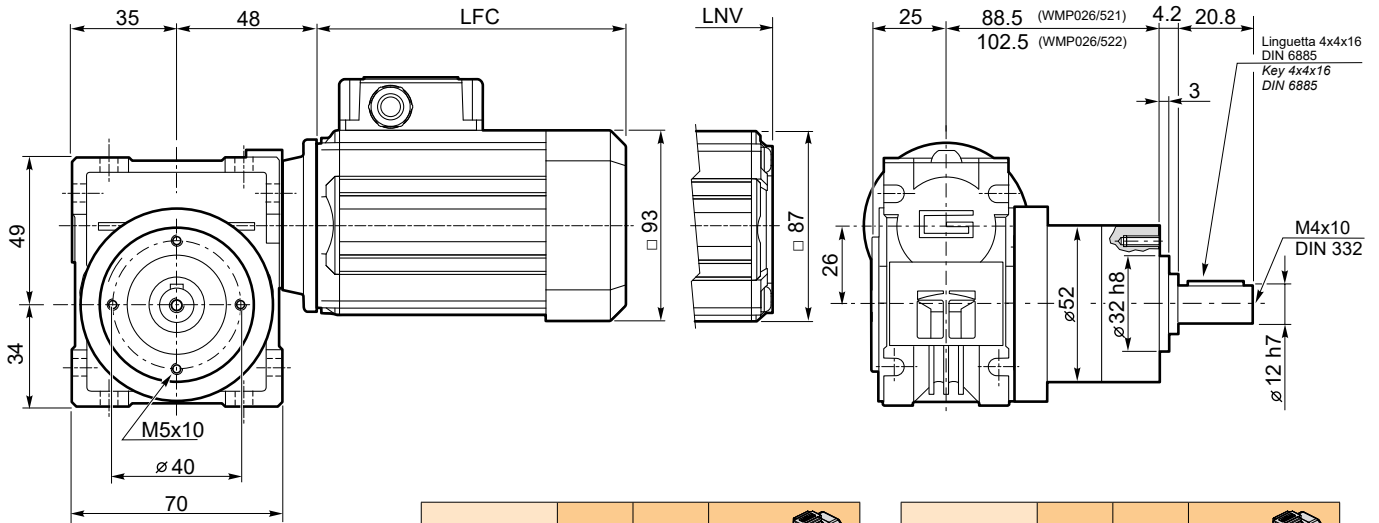

P52...C

SMT	LFC	LNV	Kg	
5624	141	117	4.6	
5634	151	127	5	
5644	186	162	6.2	
5654	206	182	6.9	

SMM	LFC	LNV	Kg	
5624	151	127	4.9	
5634	171	147	5.5	
5644	206	182	6.8	

Nota: il condensatore sarà fornito a corredo
Note: the capacitor will be supplied separately

WMP 026/621
WMP 026/622

SMT50...TEFC
SMM50... TEFC

SMT50...TENV
SMM50... TENV **S3** servizio **30%**
duty

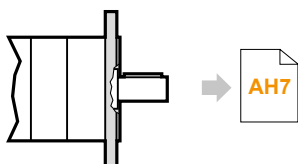
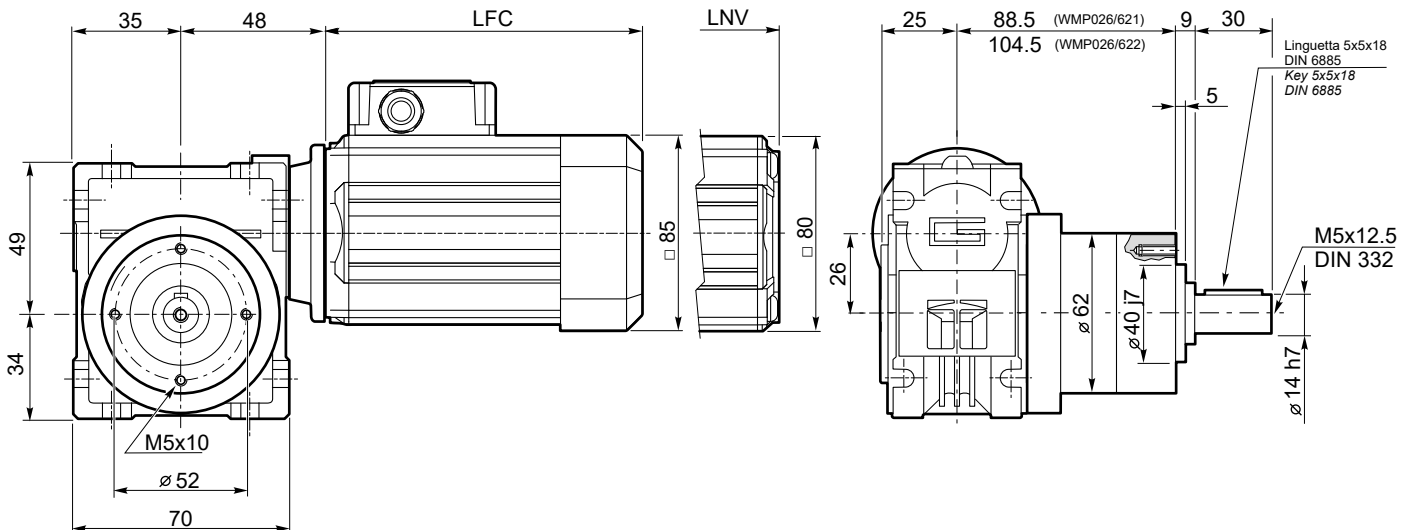

P62...C

SMT	LFC	LNV	Kg	
5014	135.5	108.5	4.4	
5024	150.5	123.5	4.8	
5034	175.5	148.5	5.6	
5044	200.5	173.5	6.3	

SMM	LFC	LNV	Kg	
5014	150.5	123.5	4.8	
5024	175.5	148.5	5.6	
5034	200.5	173.5	6.3	

Nota: il condensatore sarà fornito a corredo
Note: the capacitor will be supplied separately

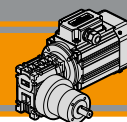

Dimensioni

Dimensions

WMP 026/621
WMP 026/622

SMT56...TEFC
SMM56... TEFC

SMT56...TENV
SMM56... TENV

S3 servizio 30%
duty

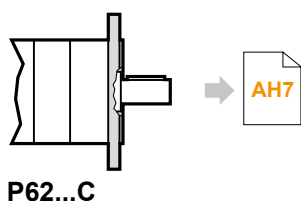
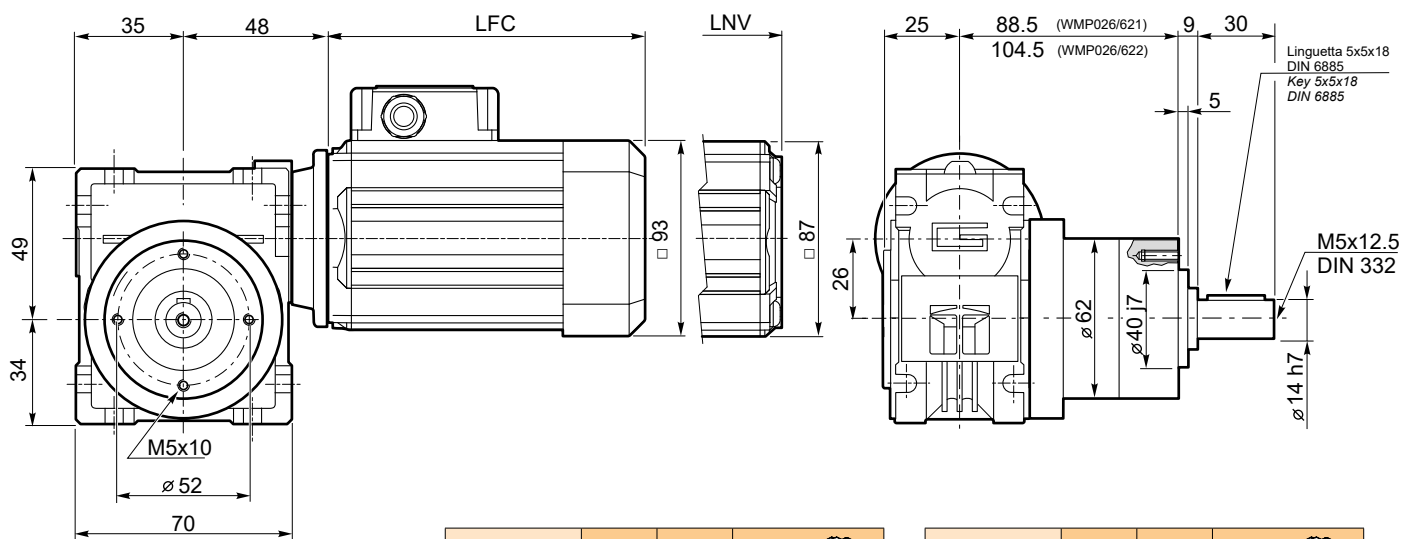

SMT	LFC	LNV	Kg	
5624	141	117	4.9	
5634	151	127	5.3	
5644	186	162	6.5	
5654	206	182	7.2	

SMM	LFC	LNV	Kg	
5624	151	127	5.2	
5634	171	147	5.8	
5644	206	182	7.1	

Nota: il condensatore sarà fornito a corredo
Note: the capacitor will be supplied separately

P.../... C... Flange uscita / Output flanges

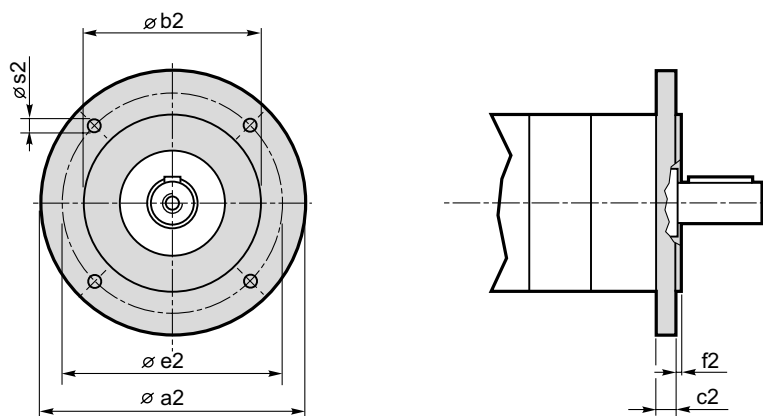

Dimensioni / Dimensions							
P	a2	b2	c2	e2	f2	s2	Flangia uscita Output flange
52	80	50 j7	9	65	2.5	M5	C80
	90	60 j7	9	75	2.5	5.5	C90
	105	70 j7	9	85	2.5	6.5	C105
	120	80 j7	9	100	3.0	6.5	C120
62	80	50 j7	9	65	2.5	M5	C80
	90	60 j7	9	75	2.5	5.5	C90
	105	70 j7	9	85	2.5	6.5	C105
	120	80 j7	9	100	3.0	6.5	C120

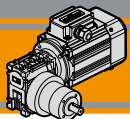

Note/Notes

MINI  **TECNO**
small but strong



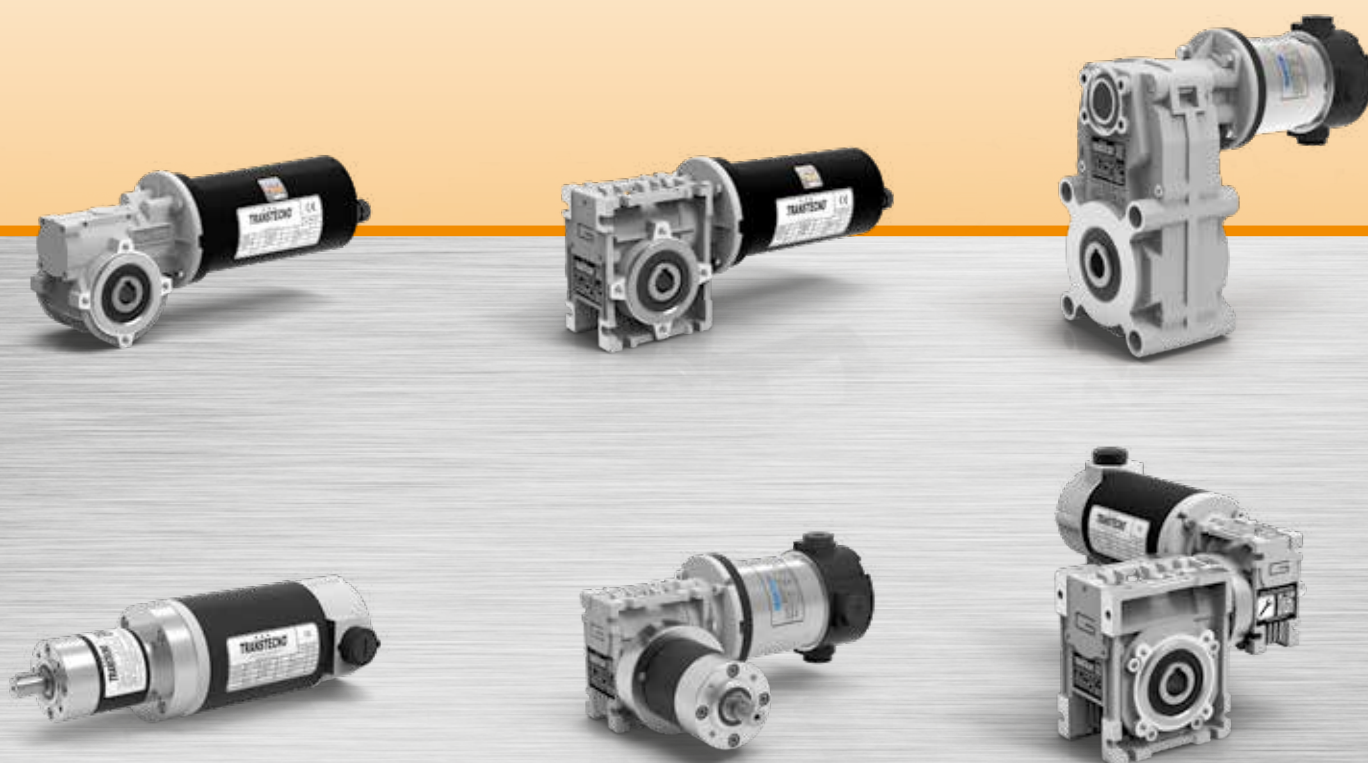













Motoriduttori CC
DC gearmotors



DC

MINI  **TECNO** brand of
TRANSTECNO



	Indice	Index	Pag. Page
	B-A Motori elettrici CC - Neodimio ND	DC Electric motors - Neodymium ND	B-A1
	B-B Motori elettrici CC - Ferrite EC	DC Electric motors - Ferrite EC	B-B1
 	B-C Motori elettrici CC IP66 - Ferrite EC IP66	IP66 DC Electric motors - Ferrite EC IP66	B-C1
 	B-D Motoriduttori CC ad ingranaggi cilindrici NDCMG - ECMG	DC Helical in-line garmotors NDCMG - ECMG	B-D1
 	B-E Motoriduttori CC ad assi ortogonali NDCMB - ECMB	DC Helical bevel gearmotors NDCMB - ECMB	B-E1
 	B-F Motoriduttori CC pendolari NDFT - ECFT	DC Helical parallel gearmotors NDFT - ECFT	B-F1
	B-G Motoriduttori CC a vite senza fine NDCM - ECM	DC Wormgearmotors NDCM - ECM	B-G1
	B-H Motoriduttori CC a vite senza fine con precoppia NDCMP - ECMP	DC Pre stage wormgearmotors NDCMP - ECMP	B-H1
	B-I Motoriduttori CC a vite senza fine combinati ECMM	DC Double reduction wormgearmotors ECMM	B-I1
 	B-L Motoriduttori CC epicicloidali NDP - ECP	DC planetary gearmotors NDP - ECP	B-L1
	B-M Motoriduttori CC combinati NDWMP - ECWMP	DC Double reduction gearmotors NDWMP - ECWMP	B-M1
	B-N Azionamenti per motori CC PLN	DC Motor controls PLN	B-N1

Questo catalogo annulla e sostituisce ogni precedente edizione o revisione.
Ci riserviamo inoltre il diritto di apportare modifiche senza preavviso.
La versione più aggiornata è disponibile sul sito
www.transtecno.com

*This catalogue supersedes any previous edition and revision.
We reserve the right to implement modifications without notice.
The most updated version is available on our website
www.transtecno.com*

Motori elettrici CC - Neodimio
DC electric motors - Neodymium



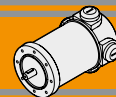

	Indice	Index	Pag. Page
	Caratteristiche tecniche	<i>Technical Features</i>	BA2
	Grado di protezione IP	<i>IP enclosures protection indexes</i>	BA3
	Classe di isolamento termico	<i>Insulation class</i>	BA3
	Tipi di servizio IEC	<i>IEC duty cycle ratings</i>	BA3
ND120.120	Caratteristiche	<i>Features</i>	BA4
ND120.240	Dimensioni	<i>Dimensions</i>	BA4
	Prestazioni	<i>Performances</i>	BA5
ND180.120	Caratteristiche	<i>Features</i>	BA6
ND180.240	Dimensioni	<i>Dimensions</i>	BA6
	Prestazioni	<i>Performances</i>	BA7
	Legenda / Glossario dei grafici	<i>Key / Diagram Glossary</i>	BA8
	Formule utili	<i>Useful formulas</i>	BA8
	Freni	<i>Brakes</i>	BA9
	Encoder	<i>Encoder</i>	BA9

Questa sezione annulla e sostituisce ogni precedente edizione o revisione. Qualora questa sezione non Vi sia giunta in distribuzione controllata, l'aggiornamento dei dati ivi contenuto non è assicurato. **In tal caso la versione più aggiornata è disponibile sul nostro sito internet www.transtecno.com**

This section replaces any previous edition and revision. If you obtained this catalogue other than through controlled distribution channels, the most up to date content is not guaranteed. In this case the latest version is available on our web site www.transtecno.com

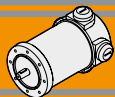

Caratteristiche tecniche

I magneti in Neodimio (NdFeB) fanno parte dei magneti a terre rare e sono attualmente i magneti più potenti in produzione. Dotati di alta forza coercitiva (resistenza alla smagnetizzazione) ed alto valore di saturazione magnetica, sono in grado di immagazzinare moltissima energia magnetica. Pertanto, i motori CC dotati di magneti in Neodimio forniscono alti valori di coppia pur in dimensioni ridotte, grazie all'alta densità di flusso del campo magnetico.

Le caratteristiche principali dei motori elettrici CC a magneti permanenti in neodimio ND sono:

- Campo magnetico generato da magneti permanenti in Neodimio (NdFeB)
- Costruzione tubolare senza ventilazione
- Disponibili in una grandezza diametro 65
- Alimentazione a bassa tensione 12 o 24 Vcc
- Potenza 160W e 250W S2
- Elevata coppia di spunto
- Maggiori coppie e potenze rispetto ai corrispettivi motori a magneti permanenti standard (a parità di dimensioni)
- Predisposizione encoder / freno

Classe di isolamento termico

Gli avvolgimenti del rotore sono soggetti a surriscaldamento, come pure altre parti del motore. Il grado di isolamento indica la massima temperatura ammissibile oltre la quale l'isolante della matassa e l'isolante di tutte le parti soggette ad elevato riscaldamento perde le caratteristiche di buon isolante, con pericolo di danneggiamento del motore.

Servizio

Rappresenta la relazione tra il tempo di lavoro ed il tempo di riposo del motore. Servizio continuo (S1) = funzionamento continuo del motore a pieno carico.

Servizio intermittente (S2, S3, etc...) = periodi alternati di lavoro e di riposo tali da raffreddare il motore. Dato un motore, la potenza espressa per servizio continuo è inferiore a quella per servizio intermittente.

Fattore di forma

Indica quanta componente spuria alternata è presente nella alimentazione CC del motore. Più alto è il fattore ed inferiore è l'efficienza del motore. Alimentatori ad SCR = F.F 1.40. Alimentazione pura da batteria = FF 1 Alimentazione da transistori (modulazione PWM) = FF 1.05.

Qualitativamente l'andamento della coppia (percentuale) rispetto al fattore di forma è indicato nel grafico seguente:

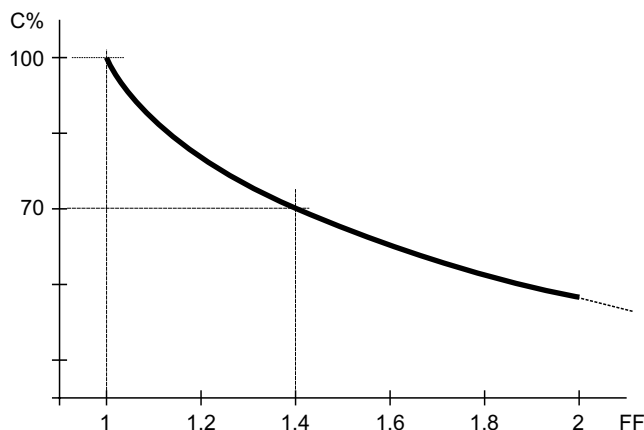

Technical features

Neodymium magnet (NdFeB) is a type of rare-earth magnet and is currently the strongest type of permanent magnets. Due to high coercivity resistance to being demagnetized and high saturation magnetization, they have potential for storing large amounts of magnetic energy. Therefore permanent Neodymium magnets DC motors can provide high torque in compact size due to the high density flux of magnet field.

The main features of ND neodymium permanent magnets DC electric motors range are:

- *Magnetic field generated by Neodymium (NdFeB) permanent magnets*
- *Tubular construction without fan*
- *Available in one size diameter 65*
- *Low voltage power supply 12 or 24 Vdc*
- *Power ratings available 160W and 250W S2*
- *High starting torque*
- *Higher torque and higher power than standard permanent magnet D.C. motors.*
- *Suitable for encoder / brake assembly*

Thermal insulation class

The windings of the rotor can overheat just like other parts of the motor too. The degree of insulation indicates the maximum allowable temperature above which the insulation of the windings, as well as that of all the parts which heat up to a high temperature, loses its insulating properties and the motor therefore risks being damaged.

Duty cycle

This represents the relationship between the time the motor operates and the time it remains stationary. Continuous operation (S1) = the motor operates non-stop under full load.

Intermittent operation (S2, S3, etc.) = alternating periods of work and rest so that the motor can cool down. The output power for continuous operation is lower than that for intermittent operation.

Form factor

It indicates how much spurious alternating current is present in the D.C. motor power supply. The higher the factor, the lower the motor's efficiency. SCR power supplies = F.F 1.40. Battery supply = FF 1 Transistor supply (PWM modulation) = FF 1.05.

The graph below indicates the torque trend (percentage) in relation to the form factor:

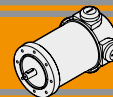
Grado di protezione IP
IP enclosures protection indexes

Indica il grado di isolamento meccanico del corpo motore.

Indicates the degree of mechanical insulation of the motor body.

1^a cifra: protezione alla penetrazione di corpi solidi.

1st figure: indicating level of protection against the penetration of solid bodies.

2^a cifra: protezione contro la penetrazione d'acqua.

2nd figure: indicating degree to which the motor is waterproof.

0	Non protetto / No protection	0	Non protetto / No protection
1	Protetto da corpi solidi superiori a Ø 50 mm. <i>Protected against solid matters (over Ø 50 mm)</i>	1	Protetto contro la caduta verticale di gocce d'acqua. <i>Protected against drops of water falling vertically</i>
2	Protetto da corpi solidi superiori a Ø 12 mm. <i>Protected against solid matters (over Ø 12 mm)</i>	2	Protetto contro la caduta verticale di gocce d'acqua con inclinazione max di 15° <i>Protected against drops of water falling up to 15°</i>
3	Protetto da corpi solidi superiori a Ø 2.5 mm. <i>Protected against solid matters (over Ø 2.5 mm)</i>	3	Protetto contro la pioggia. <i>Rain proof fixture</i>
4	Protetto da corpi solidi superiori a Ø 1 mm. <i>Protected against solid matters (over Ø 1 mm)</i>	4	Protetto contro gli spruzzi. <i>Splash proof fixture</i>
5	Protetto contro la polvere <i>Dust proof</i>	5	Protetto contro getti d'acqua <i>Water jet proof</i>
6	Totalmente protetto contro la polvere <i>Fully dust proof</i>	6	Protetto dalle ondate <i>Wave proof</i>
7	N.A.	7	Protetto contro immersione <i>Watertight immersion fixture.</i>
8	N.A.	8	Protetto contro immersione/sommersione prolungata <i>Watertight immersion fixture for a long time.</i>

Classe di isolamento termico
Insulation class

Classe / Class	Δt °C Temp. ambiente: 40°C Ambient temperature: 40°C
A	65°C
B	90°C
F	115°C
H	140°C

Tipi di servizio IEC
IEC duty cycle ratings

S1	Servizio continuo. Funzionamento a carico costante per una durata sufficiente al raggiungimento dell'equilibrio termico.	Continuous duty. The motor works at a constant load for enough time to reach temperature equilibrium
S2	Servizio di durata limitata. Funzionamento a carico costante per una durata inferiore a quella necessaria al raggiungimento dell'equilibrio termico, seguito da un periodo di riposo tale da riportare il motore alla temperatura ambiente.	Short time duty. The motor works at a constant load, but not long enough to reach temperature equilibrium, and the rest periods are long enough for the motor to reach ambient temperature.
S3	Servizio periodico intermittente. Sequenze di cicli identici di marcia e di riposo a carico costante, senza raggiungimento dell'equilibrio termico. La corrente di spunto ha effetti trascurabili sul surriscaldamento del motore.	Intermittent periodic duty. Sequential, identical run and rest cycles with constant load. Temperature equilibrium is never reached. Starting current has little effect on temperature rise.
S4	Servizio periodico intermittente con avviamento. Sequenza di cicli di funzionamento identici di avviamento, marcia e riposo a carico costante, senza raggiungimento dell'equilibrio termico. La corrente di spunto ha effetti sul riscaldamento del motore.	Intermittent periodic duty with starting. Sequential identical start, run and rest cycles with constant load. Temperature equilibrium is not reached, but starting current affects temperature rise.
S5	Servizio periodico intermittente con frenatura elettrica. Sequenza di cicli di funzionamento identici di avviamento, marcia a carico costante, frenatura elettrica e riposo, senza raggiungimento dell'equilibrio termico.	Intermittent periodic duty with electric braking. Sequential, identical cycles of starting, running at constant load, electric braking and rest. Temperature equilibrium is not reached.
S6	Servizio periodico ininterrotto con carico intermittente. Sequenza di cicli di lavoro identici con carico costante e senza carico. Non ci sono periodi di riposo.	Continuous operation with intermittent load. Sequential, identical cycles of running with constant load and running with no load. No rest periods.
S7	Servizio periodico ininterrotto con frenatura elettrica. Sequenza di cicli di funzionamento identici di avviamento, marcia a carico costante e frenatura elettrica, senza periodi di riposo.	Continuous operation with electric braking. Sequential, identical cycles of starting, running at constant load and electric braking. No rest periods.
S8	Servizio periodico ininterrotto con variazioni di carico e di velocità. Sequenza di cicli identici di avviamento, marcia a carico costante e velocità definita, seguiti da marcia a carico costante differente e velocità differente dalla precedente. Non ci sono periodi di riposo.	Continuous operation with periodic changes in load and speed. Sequential, identical, duty cycles of start, run at constant load and given speed, then run at other constant loads and speeds. No rest periods.

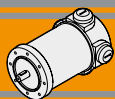
**ND**
Motori elettrici CC - Neodimio
DC Electric motors - Neodymium



ND120.120 - ND120.240

Caratteristiche
Features

Costruzione	Tubolare, senza ventilazione
Grandezza	Ø 65 mm
Potenza	160 W S2 (120 W S1)
Magneti	4 magneti in terre rare
Supporti	Cuscinetti a sfera
Fori di montaggio	8
Alimentazione	Bassa tensione, 12 o 24 Vcc
Spazzole	N° 4 di composto grafite-rame
Cavo di alimentazione	Lunghezza: 1000 mm
Bisporgenza	Standard

Construction	Tubular, without fan
Size	Ø 65 mm
Power	160 W S2 (120 W S1)
Magnets	4 rare earth magnets
Bearings	Ball bearings
Mounting holes	8
Power supply	Low voltage, 12 or 24 Vdc
Brushes	4 brushes made of graphite/copper composite
Electric cable	Length: 1000 mm
Rear Shaft	Standard

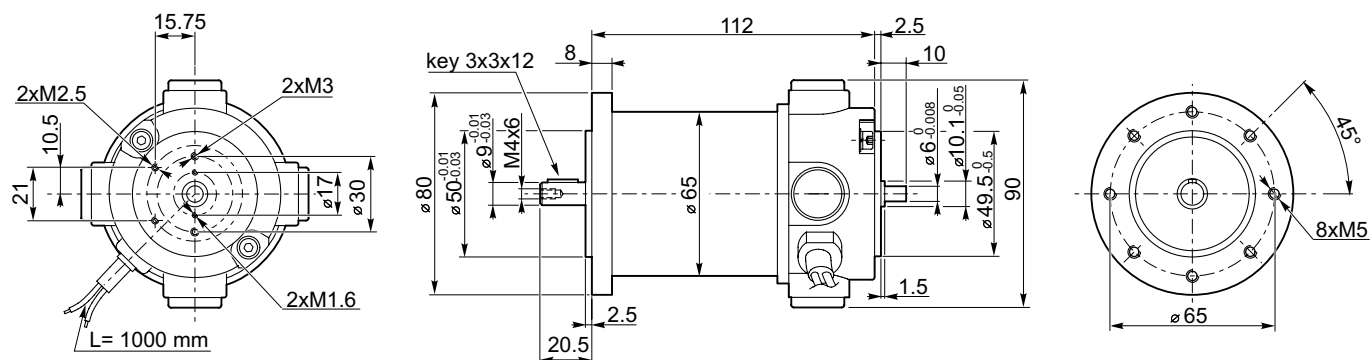
Tipo Type	S	Pn [W]	V [V]	I [A]	IC	FF	Mn [Nm]	n ₁ [min ⁻¹]	IP	Kg
ND120.120	S1	120	12	13.9	F	1	0.38	3000	20	1.6
	S2 20'	160		19			0.51			
ND120.240	S1	120	24	6.9			0.38			
	S2 20'	160		9.0			0.51			

Dimensioni
Dimensions

Freno / Brake → BA9

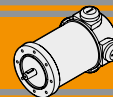
Encoder → BA9



ND120.120 - ND120.240

Prestazioni

Performances

ND120.120

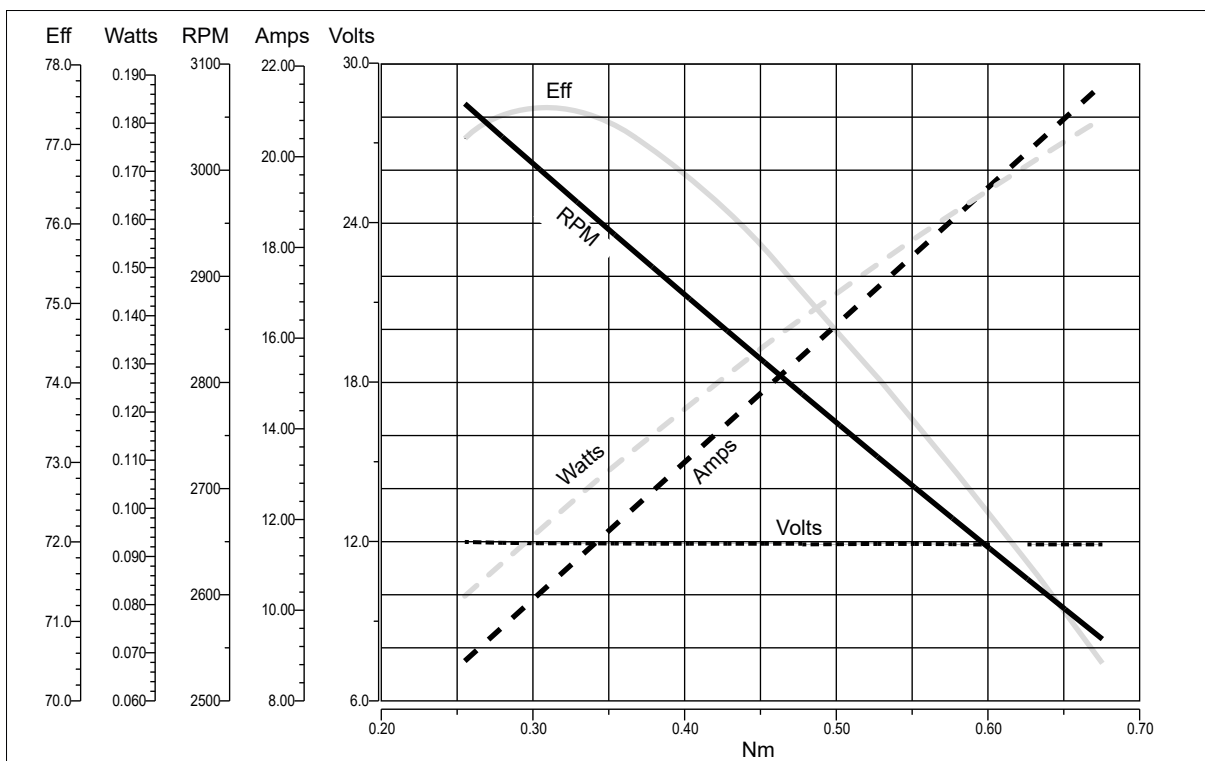

ND120.240

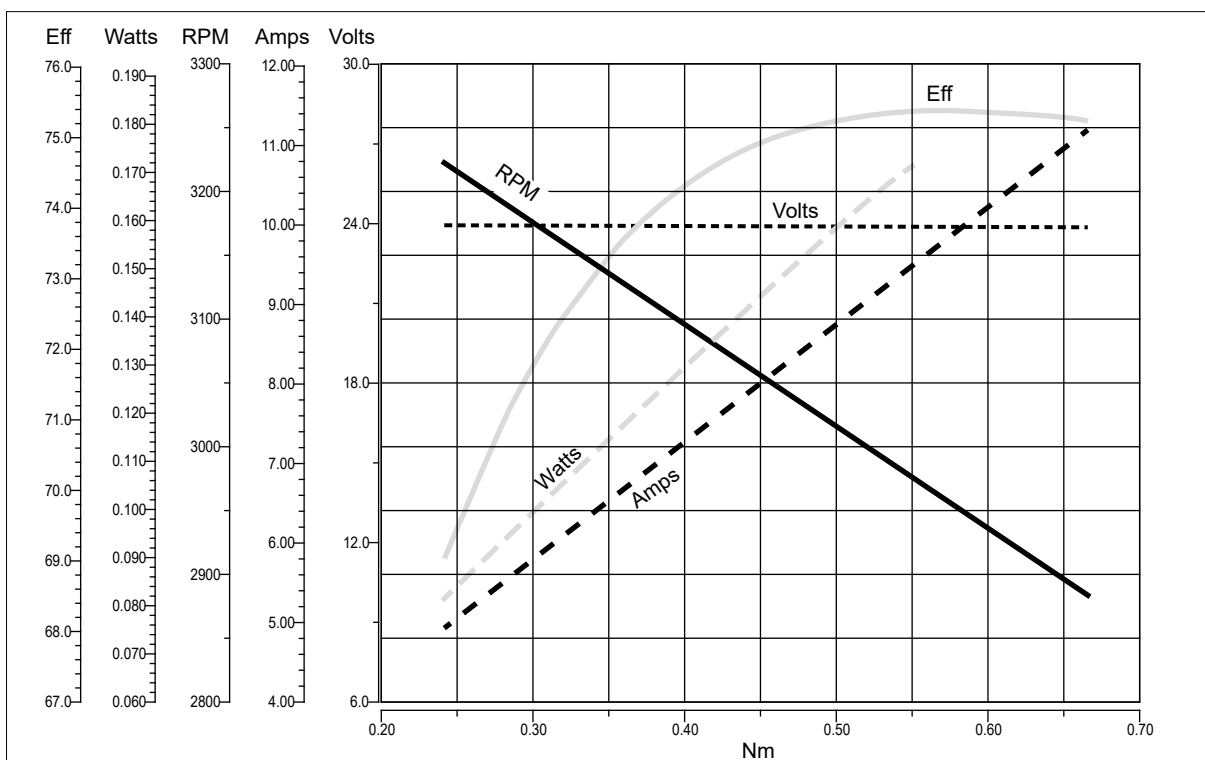

DC

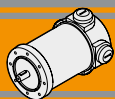
**ND**
Motori elettrici CC - Neodimio
DC Electric motors - Neodymium

ND180.120 - ND180.240

Caratteristiche

Features

Costruzione	Tubolare, senza ventilazione
Grandezza	Ø 65 mm
Potenza	250 W S2 (180 W S1)
Magneti	4 magneti in terre rare
Supporti	Cuscinetti a sfera
Fori di montaggio	8
Alimentazione	Bassa tensione, 12 o 24 Vcc
Spazzole	N° 4 di composto grafite-rame
Cavo di alimentazione	Lunghezza: 1000 mm
Bisporgenza	Standard

Construction	Tubular, without fan
Size	Ø 65 mm
Power	250 W S2 (180 W S1)
Magnets	4 rare earth magnets
Bearings	Ball bearings
Mounting holes	8
Power supply	Low voltage, 12 or 24 Vdc
Brushes	4 brushes made of graphite/copper composite
Electric cable	Length: 1000 mm
Rear Shaft	Standard

Tipo Type	S	Pn [W]	V [V]	I [A]	IC	FF	Mn [Nm]	n ₁ [min ⁻¹]	IP	Kg
ND180.120	S1	180	12	20	F	1	0.57	3000	20	1.95
	S2 20'	250		30			0.80			
ND180.240	S1	180	24	10						
	S2 20'	250		14			0.57			
							0.80			

Dimensioni

Dimensions

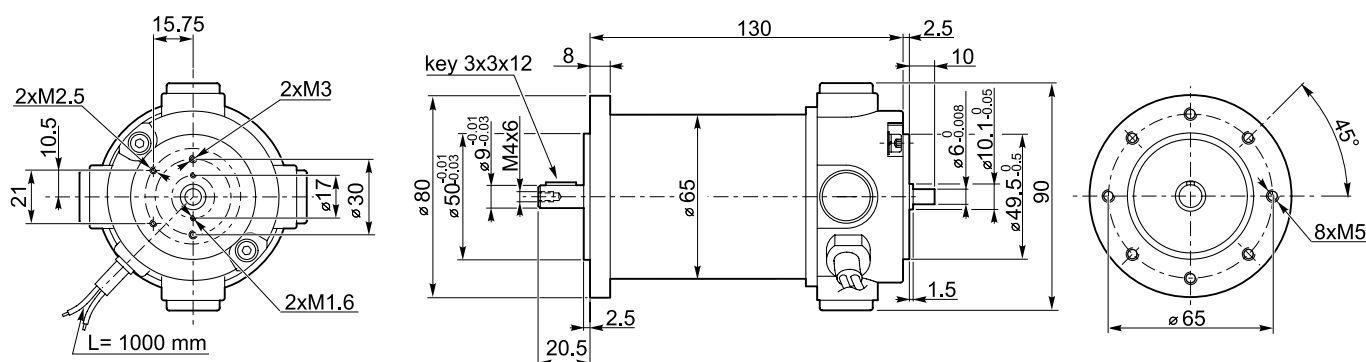

Freno / Brake → BA9

Encoder → BA9

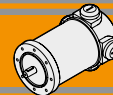

ND180.120 - ND180.240

Prestazioni

Performances

ND180.120

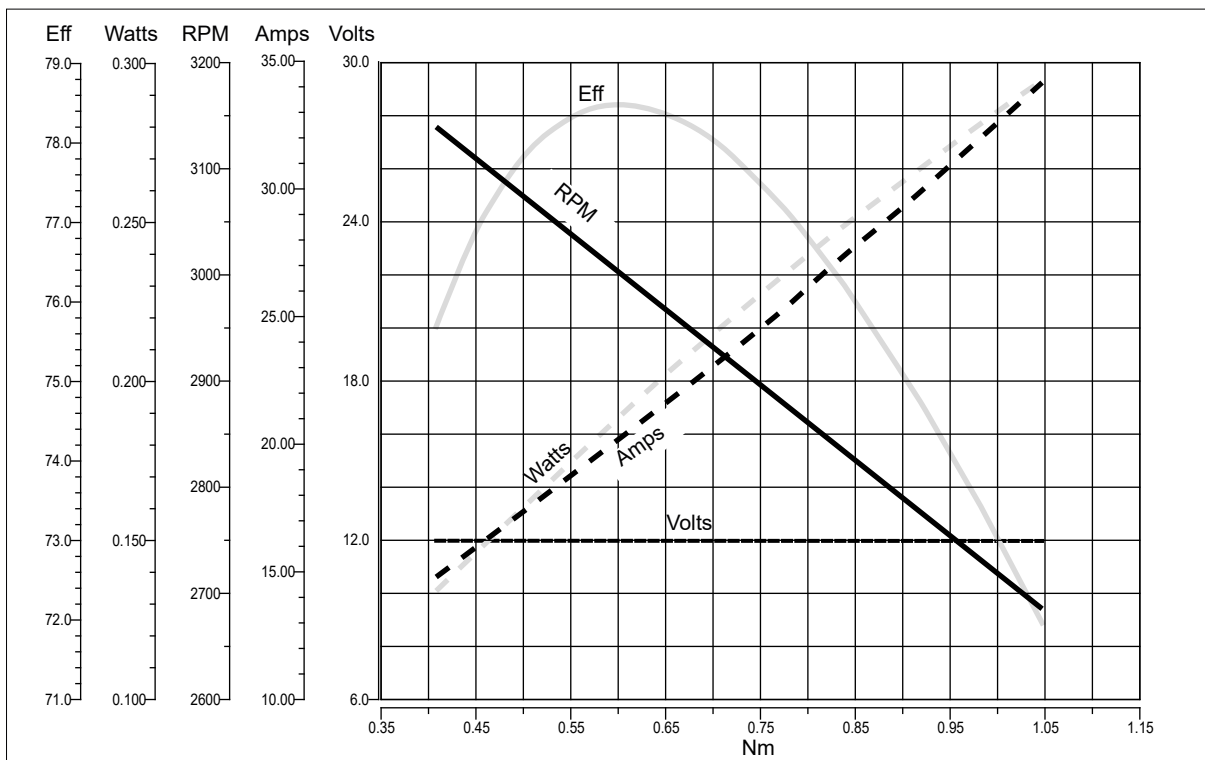

ND180.240

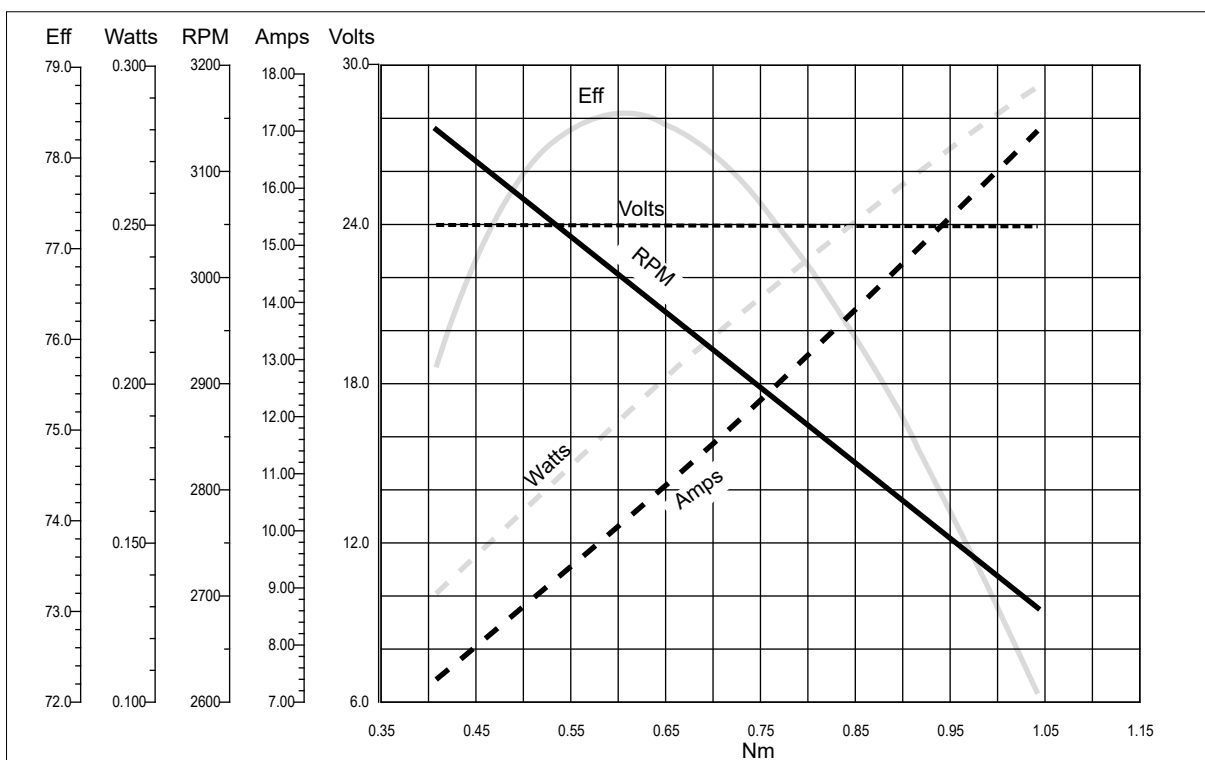

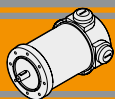

Legenda / Glossario dei grafici

Key / Diagram Glossary

Dato un motore in CC, la velocità di rotazione è funzione lineare della coppia; così pure la corrente assorbita è una funzione lineare della coppia. Velocità e corrente variano in maniera sensibile al variare del carico.

With a DC motor, the rotational speed is a linear function of the torque. In the same way, the absorbed current is also a linear function of the torque. Speed and current change a lot against applied torque.

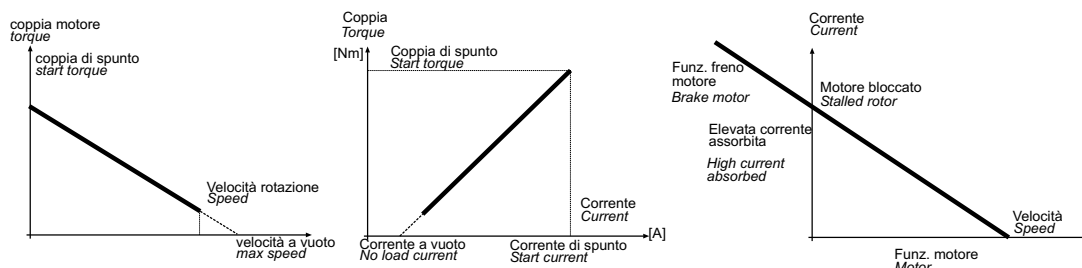

La potenza utile (potenza all'albero) si ricava dalla formula:

$$P_n [W] = M_n \cdot S = \frac{2\pi}{60} \cdot n_1 \cdot M_n$$

The output power is calculated using the formula:

$$P_n [W] = M_n \cdot S = \frac{2\pi}{60} \cdot n_1 \cdot M_n$$

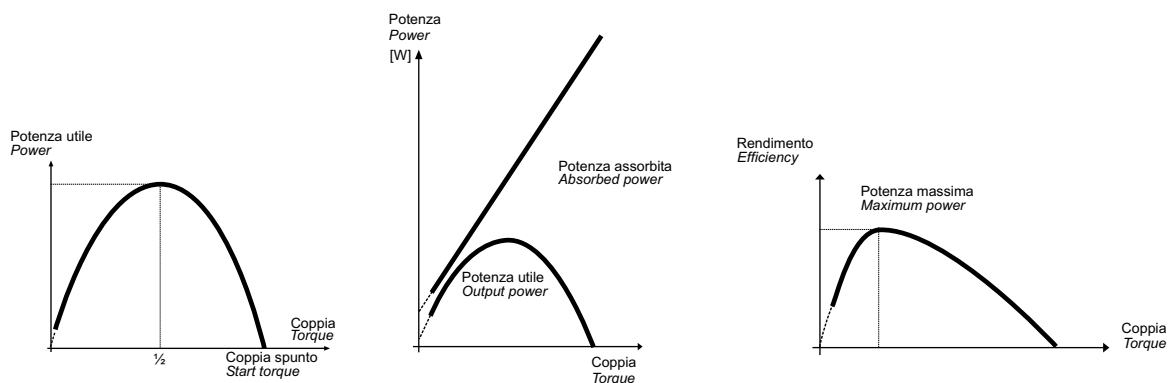

Poiché la tensione di alimentazione è costante mentre la corrente è linearmente crescente al crescere della coppia, l'andamento della potenza assorbita è una retta crescente. Dal rapporto tra la potenza meccanica e la potenza assorbita si ottiene il grafico dell'efficienza.

Since the supply voltage is constant, whereas the current increases in a linear manner as the torque increases, the absorbed power trend is a straight line going up. Efficiency is shown from the ratio between the output power and the absorbed power.

Formule utili

Useful formulas

$$\eta = \frac{P_n}{P_a}$$

$$P_a = V \cdot I$$

$$P_n = V \cdot I \cdot \eta$$

$$P_n = M_n \cdot S_v$$

$$S_v = \frac{n_1}{9.55}$$

$$\eta = \frac{P_n}{P_a}$$

$$P_a = V \cdot I$$

$$P_n = V \cdot I \cdot \eta$$

$$P_n = M_n \cdot S_v$$

$$S_v = \frac{n_1}{9.55}$$

[HP] · 746 = [W].
Esempio 2 HP = circa 1500 W.

[HP] · 746 = [W].
Example 2 HP = approx. 1500 W.

S	—	Servizio	<i>Duty</i>
P_n	[W]	Potenza in uscita	<i>Rated power</i>
P_a	[W]	Potenza assorbita	<i>Absorbed power</i>
M_n	[Nm]	Coppia nominale	<i>Rated torque</i>
V	[V]	Tensione	<i>Voltage</i>
I	[A]	Corrente assorbita	<i>Absorbed current</i>
n₁	[min ⁻¹]	Numero giri motore	<i>Motor speed</i>
S_v	[rad/s]	Velocità angolare	<i>Angular speed</i>
IC	—	Classe d'isolamento termico	<i>Thermal insulation class</i>
FF	—	Fattore di forma	<i>Form factor</i>
IP	—	Classe di protezione	<i>Protection class</i>
η	—	Rendimento	<i>Efficiency</i>
Kg	—	Peso	<i>Weight</i>

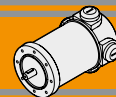

Freno

Brake

ND...BR Freno / Brake

ND...BRL Freno con leva di sblocco/ Brake with hand release

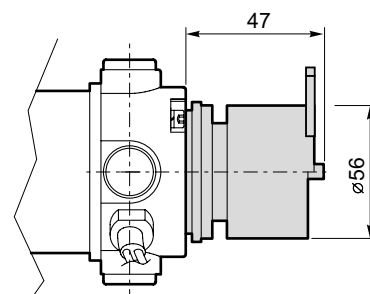
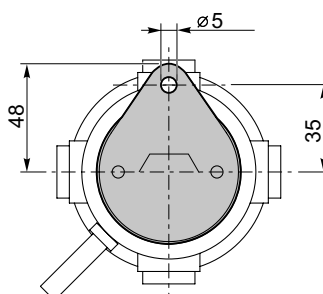
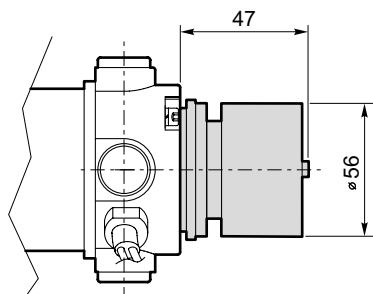

	Pn [W]	V [V]	Mn [Nm]	n ₁ [min ⁻¹]
Caratteristiche del freno / Break features	14	12	2	3000
		24		

Encoder

Encoder

ND...ME22

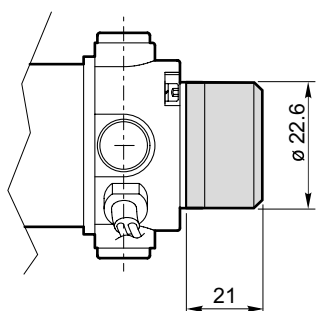

Nota: Fornito con cavo lungo 300 mm

Note: Supplie with cavle 300 mm long

Risoluzione Encoder (CPR) / Encoder Resolution (CPR)	Numero di canali / Number of channels	Tensione d'alimentazione / Power supply
001	2	5 VdC - TTL
100		
300		

Per risoluzioni encoder non standard, si prega di contattare il nostro Servizio Tecnico.

For non-standard encoder resolution, please contact our Technical Department.

MINI  **TECNO**
small but strong

EC

Motori elettrici CC - Ferrite
DC electric motors - Ferrite



MINI  **TECNO** brand of
TRANSTECNO



DC

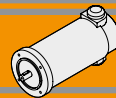

	Indice	Index	Pag. Page
	Caratteristiche tecniche	<i>Technical features</i>	BB2
	Simbologia	<i>Symbols</i>	BB2
	Grado di protezione IP	<i>IP enclosures protection indexes</i>	BB3
	Classe di isolamento termico	<i>Insulation class</i>	BB3
	Tipi di servizio IEC	<i>IEC duty cycle ratings</i>	BB3
EC020.120	Caratteristiche	<i>Features</i>	BB4
EC020.24E	Dimensioni	<i>Dimensions</i>	BB4
	Prestazioni	<i>Performances</i>	BB5
EC035.120	Caratteristiche	<i>Features</i>	BB6
EC035.240	Dimensioni	<i>Dimensions</i>	BB6
	Prestazioni	<i>Performances</i>	BB7
EC050.12E	Caratteristiche	<i>Features</i>	BB8
EC050.24E	Dimensioni	<i>Dimensions</i>	BB8
	Prestazioni	<i>Performances</i>	BB9
EC070.12E	Caratteristiche	<i>Features</i>	BB10
EC070.24E	Dimensioni	<i>Dimensions</i>	BB10
	Prestazioni	<i>Performances</i>	BB11
EC100.120	Caratteristiche	<i>Features</i>	BB12
EC100.240	Dimensioni	<i>Dimensions</i>	BB12
EC100.24E	Prestazioni	<i>Performances</i>	BB13
EC180.120	Caratteristiche	<i>Features</i>	BB14
EC180.240	Dimensioni	<i>Dimensions</i>	BB14
EC180.24E	Prestazioni	<i>Performances</i>	BB15
EC250.120	Caratteristiche	<i>Features</i>	BB16
EC250.240	Dimensioni	<i>Dimensions</i>	BB16
	Prestazioni	<i>Performances</i>	BB17
EC350.120	Caratteristiche	<i>Features</i>	BB18
EC350.240	Dimensioni	<i>Dimensions</i>	BB18
	Prestazioni	<i>Performances</i>	BB19
EC600.120	Caratteristiche	<i>Features</i>	BB20
EC600.240	Dimensioni	<i>Dimensions</i>	BB20
	Prestazioni	<i>Performances</i>	BB21
	Legenda / Glossario dei grafici	<i>Key / Diagram Glossary</i>	BB22
	Formule utili	<i>Useful formulas</i>	BB22
	Freni	<i>Brakes</i>	BB23
	Encoder	<i>Encoder</i>	BB24

Questa sezione annulla e sostituisce ogni precedente edizione o revisione. Qualora questa sezione non Vi sia giunta in distribuzione controllata, l'aggiornamento dei dati ivi contenuto non è assicurato. **In tal caso la versione più aggiornata è disponibile sul nostro sito internet www.transtecno.com**

This section replaces any previous edition and revision. If you obtained this catalogue other than through controlled distribution channels, the most up to date content is not guaranteed. In this case the latest version is available on our web site www.transtecno.com

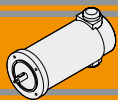

Caratteristiche tecniche

Technical features

Le caratteristiche principali dei motori elettrici CC a magneti permanenti in ferrite EC sono:

- Campo magnetico generato da magneti permanenti in ferrite
- Costruzione tubolare, senza ventilazione
- Disponibili in 6 grandezze: diametro 42, 52, 65, 81, 104, 110 mm
- Alimentazione a bassa tensione, 12 o 24 Vcc
- Potenze disponibili da 30 a 800 W S2
- Elevate coppie di spunto
- Elevate coppie e potenze in dimensioni compatte

The main features of EC ferrite permanent magnets DC electric motors range are:

- Magnetic field generated by permanent ferrite magnets
- Tubular construction, without fan
- Available in 6 sizes: diameter 42, 52, 65, 81, 104, 110 mm
- Low voltage power supply, 12 or 24 Vdc
- Power ratings available from 30 to 800 W S2
- High starting torque
- High torque and output power with compact package

Classe di isolamento termico

Gli avvolgimenti del rotore sono soggetti a surriscaldamento, come pure altre parti del motore. Il grado di isolamento indica la massima temperatura ammissibile oltre la quale l'isolante della matassa e l'isolante di tutte le parti soggette ad elevato riscaldamento perde le caratteristiche di buon isolante, con pericolo di danneggiamento del motore.

Thermal insulation class

The windings of the rotor can overheat just like other parts of the motor too. The degree of insulation indicates the maximum allowable temperature above which the insulation of the windings, as well as that of all the parts which heat up to a high temperature, loses its insulating properties and the motor therefore risks being damaged.

Servizio

Rappresenta la relazione tra il tempo di lavoro ed il tempo di riposo del motore. Servizio continuo (S1) = funzionamento continuo del motore a pieno carico.

Servizio intermittente (S2, S3, etc...) = periodi alternati di lavoro e di riposo tali da raffreddare il motore. Dato un motore, la potenza espressa per servizio continuo è inferiore a quella per servizio intermittente.

Duty cycle

This represents the relationship between the time the motor operates and the time it remains stationary. Continuous operation (S1) = the motor operates non-stop under full load.

Intermittent operation (S2, S3, etc...) = alternating periods of work and rest so that the motor can cool down. The output power for continuous operation is lower than that for intermittent operation.

Fattore di forma

Indica quanta componente spuria alternata è presente nella alimentazione CC del motore. Più alto è il fattore ed inferiore è l'efficienza del motore. Alimentatori ad SCR = F.F 1.40. Alimentazione pura da batteria = FF 1. Alimentazione da transistori (modulazione PWM) = FF 1.05.

Qualitativamente l'andamento della coppia (percentuale) rispetto al fattore di forma è indicato nel grafico seguente:

Form factor

It indicates how much spurious alternating current is present in the D.C. motor power supply. The higher the factor, the lower the motor's efficiency. SCR power supplies = F.F 1.40. Battery supply = FF 1 Transistor supply (PWM modulation) = FF 1.05.

The graph below indicates the torque trend (percentage) in relation to the form factor.

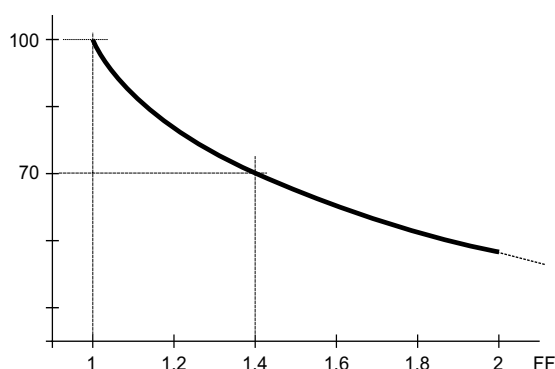

Simbologia

Symbols

S	—	Servizio / Duty	M_{Br}	[Nm]	Coppia nominale del freno / Brake motor torque
P_n	[W]	Potenza in uscita / Rated power	n_{1 max}	[min ⁻¹]	Velocità massima / Max speed
P_a	[W]	Potenza assorbita / Absorbed power	T_r	[ms]	Tempo di inserzione / Engaging time
M_n	[Nm]	Coppia nominale / Rated torque	T_f	[ms]	Tempo di disimpegno / Disengaging time
V	[V]	Tensione / Voltage	IC	—	Classe d'isolamento termico / Thermal insulation class
I	[A]	Corrente assorbita / Absorbed current	FF	—	Fattore di forma / Form factor
n₁	[min ⁻¹]	Numero giri motore / Motor speed	IP	—	Classe di protezione / Protection class
S_v	[rad/s]	Velocità angolare / Angular speed	η	—	Rendimento / Efficiency
P_e	[W]	Potenza elettrica del freno / Brake electric power	K_g	—	Peso / Weight

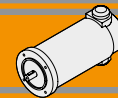
Grado di protezione IP
IP enclosures protection indexes

Indica il grado di isolamento meccanico del corpo motore.

Indicates the degree of mechanical insulation of the motor body.

1ª cifra protezione alla penetrazione di corpi solidi.

 1st figure indicating level of protection against the penetration of solid bodies.

2ª cifra protezione contro la penetrazione d'acqua.

 2nd figure: indicating degree to which the motor is waterproof.

0	Non protetto / No protection	0	Non protetto / No protection
1	Protetto da corpi solidi superiori a Ø 50 mm. <i>Protected against solid matters (over Ø 50 mm)</i>	1	Protetto contro la caduta verticale di gocce d'acqua. <i>Protected against drops of water falling vertically</i>
2	Protetto da corpi solidi superiori a Ø 12 mm. <i>Protected against solid matters (over Ø 12 mm)</i>	2	Protetto contro la caduta verticale di gocce d'acqua con inclinazione max di 15° <i>Protected against drops of water falling up to 15°</i>
3	Protetto da corpi solidi superiori a Ø 2,5 mm. <i>Protected against solid matters (over Ø 2,5 mm)</i>	3	Protetto contro la pioggia. <i>Rain proof fixture</i>
4	Protetto da corpi solidi superiori a Ø1 mm. <i>Protected against solid matters (over Ø1 mm)</i>	4	Protetto contro gli spruzzi. <i>Splash proof fixture</i>
5	Protetto contro la polvere <i>Dust proof</i>	5	Protetto contro getti d'acqua <i>Water jet proof</i>
6	Totalmente protetto contro la polvere <i>Fully dust proof</i>	6	Protetto dalle ondate <i>Wave proof</i>
7	N.A.	7	Protetto contro immersione <i>Watertight immersion fixture.</i>
8	N.A.	8	Protetto contro immersione/sommersione prolungata <i>Watertight immersion fixture for a long time.</i>

Classe di isolamento termico
Insulation class

Classe / Class	Δt °C Temp. ambiente: 40°C <i>Ambient temperature: 40°C</i>
A	65°C
B	90°C
F	115°C
H	140°C

Tipi di servizio IEC
IEC duty cycle ratings

S1	Servizio continuo. Funzionamento a carico costante per una durata sufficiente al raggiungimento dell' equilibrio termico.	Continuous duty. The motor works at a constant load for enough time to reach temperature equilibrium
S2	Servizio di durata limitata. Funzionamento a carico costante per una durata inferiore a quella necessaria al raggiungimento dell' equilibrio termico, seguito da un periodo di riposo tale da riportare il motore alla temperatura ambiente.	Short time duty. The motor works at a constant load, but not long enough to reach temperature equilibrium, and the rest periods are long enough for the motor to reach ambient temperature.
S3	Servizio periodico intermittente. Sequenze di cicli identici di marcia e di riposo a carico costante, senza raggiungimento dell' equilibrio termico. La corrente di spunto ha effetti trascurabili sul surriscaldamento del motore.	Intermittent periodic duty. Sequential, identical run and rest cycles with constant load. Temperature equilibrium is never reached. Starting current has little effect on temperature rise.
S4	Servizio periodico intermittente con avviamento. Sequenza di cicli di funzionamento identici di avviamento, marcia e riposo a carico costante, senza raggiungimento dell'equilibrio termico. La corrente di spunto ha effetti sul riscaldamento del motore.	Intermittent periodic duty with starting. Sequential identical start, run and rest cycles with constant load. Temperature equilibrium is not reached, but starting current affects temperature rise.
S5	Servizio periodico intermittente con frenatura elettrica. Sequenza di cicli di funzionamento identici di avviamento, marcia a carico costante, frenatura elettrica e riposo, senza raggiungimento dell'equilibrio termico.	Intermittent periodic duty with electric braking. Sequential, identical cycles of starting, running at constant load, electric braking and rest. Temperature equilibrium is not reached.
S6	Servizio periodico ininterrotto con carico intermittente. Sequenza di cicli di lavoro identici con carico costante e senza carico. Non ci sono periodi di riposo.	Continuous operation with intermittent load. Sequential, identical cycles of running with constant load and running with no load. No rest periods.
S7	Servizio periodico ininterrotto con frenatura elettrica. Sequenza di cicli di funzionamento identici di avviamento, marcia a carico costante e frenatura elettrica, senza periodi di riposo.	Continuous operation with electric braking. Sequential, identical cycles of starting, running at constant load and electric braking. No rest periods.
S8	Servizio periodico ininterrotto con variazioni di carico e di velocità. Sequenza di cicli identici di avviamento, marcia a carico costante e velocità definita, seguiti da marcia a carico costante differente e velocità differente dalla precedente. Non ci sono periodi di riposo.	Continuous operation with periodic changes in load and speed. Sequential, identical, duty cycles of start, run at constant load and given speed, then run at other constant loads and speeds. No rest periods.

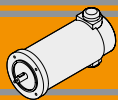

EC020.120 - EC020.24E

Caratteristiche

Features

Costruzione	Tubolare, senza ventilazione
Grandezza	Ø 42 mm
Potenza	30 W S2 (20 W S1)
Magneti	2
Supporti	Cuscinetti a sfera
Fori di montaggio	4
Alimentazione	Bassa tensione, 12 o 24 Vcc
Spazzole	N° 2 di composto grafite-rame
Cavo di alimentazione	Connettori faston (0.8 x 2.8 mm)
Opzioni	Filtro EMC
	Encoder magnetico max. 2 imp/giro, 2 canali Max.

Construction	Tubular, without fan
Size	Ø 42 mm
Power	30 W S2 (20 W S1)
Magnets	2
Bearings	Ball bearing
Mounting holes	4
Power supply	Low voltage, 12 or 24 Vdc
Brushes	2 brushes made of graphite/copper composite
Electric cable	Faston terminals (0.8 x 2.8 mm)
Options	EMC filter
	Magnetic encoder max 2 ppr, Max. 2 channels

Tipo Type	S	Pn [W]	V [V]	I [A]	IC	FF	Mn [Nm]	n ₁ [min ⁻¹]	IP	Kg
EC020.120	S1	20	12	2.6	B	1	0.06	2850	20	0.4
	S2 6'	30		3.5			0.08			
EC020.24E	S1	20	24	1.4			0.06			
	S2 6'	30		1.9			0.08			

Dimensioni

Dimensions

EC020.120

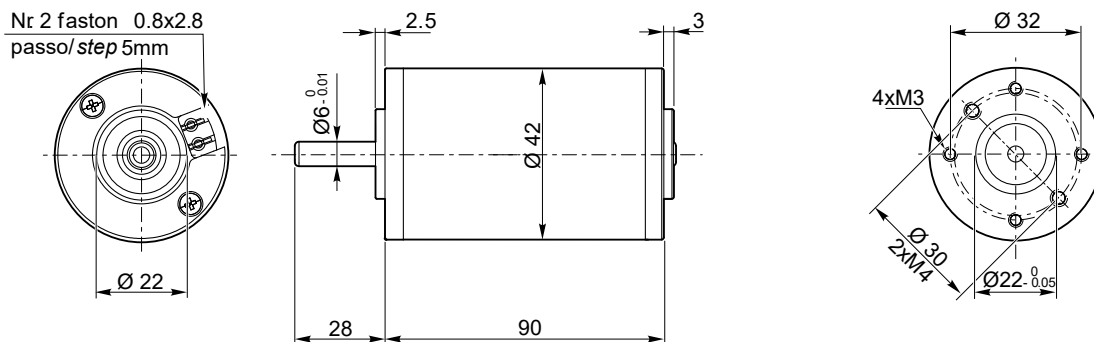

EC020.24E

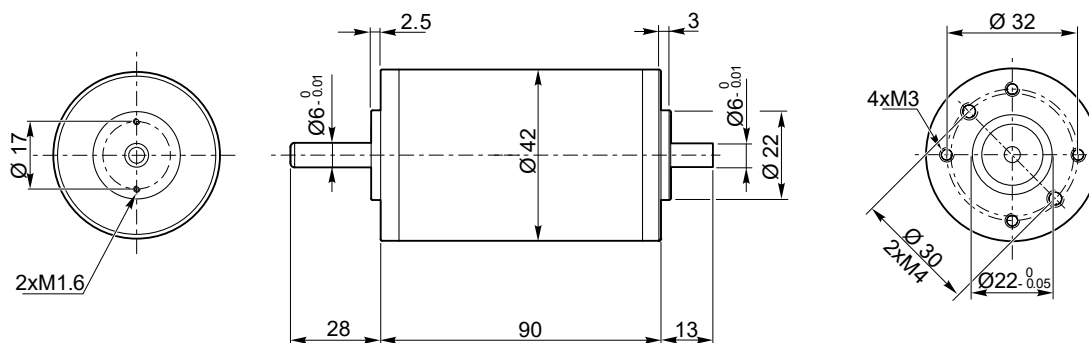

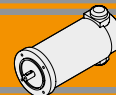

EC020.120 - EC020.24E

Prestazioni

Performances

EC020.120

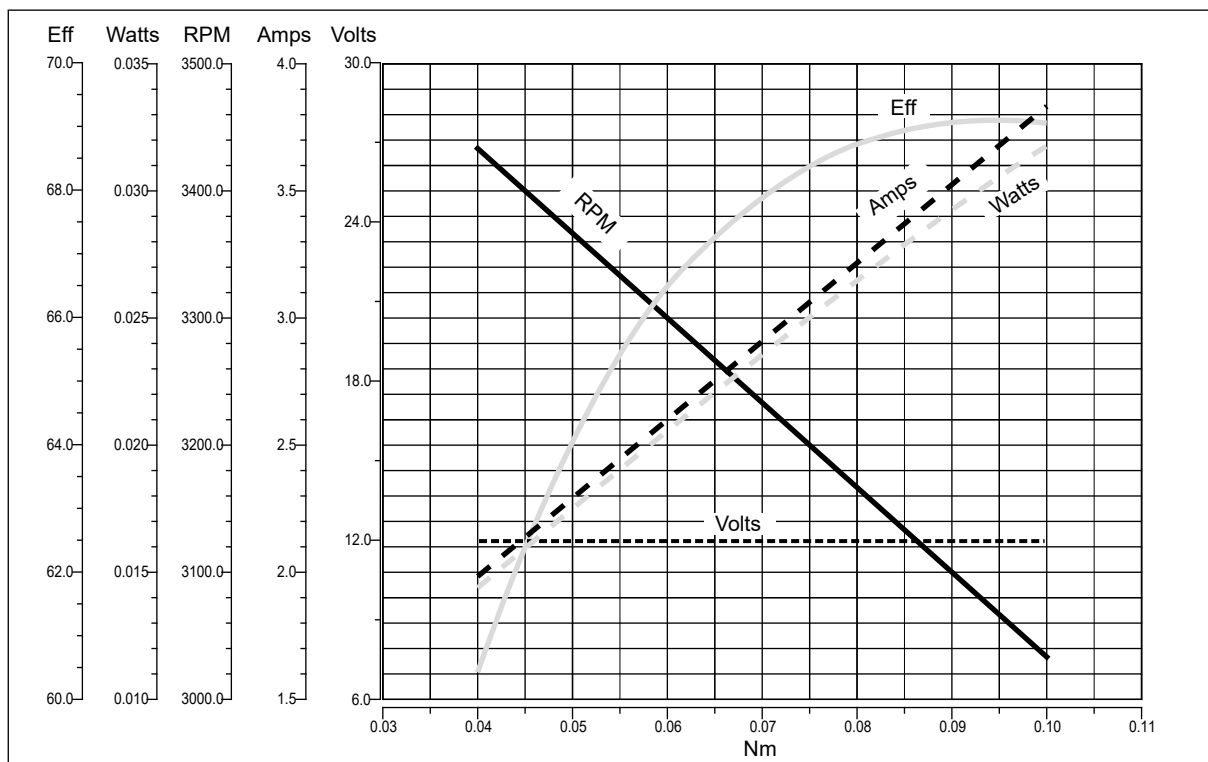

EC020.24E

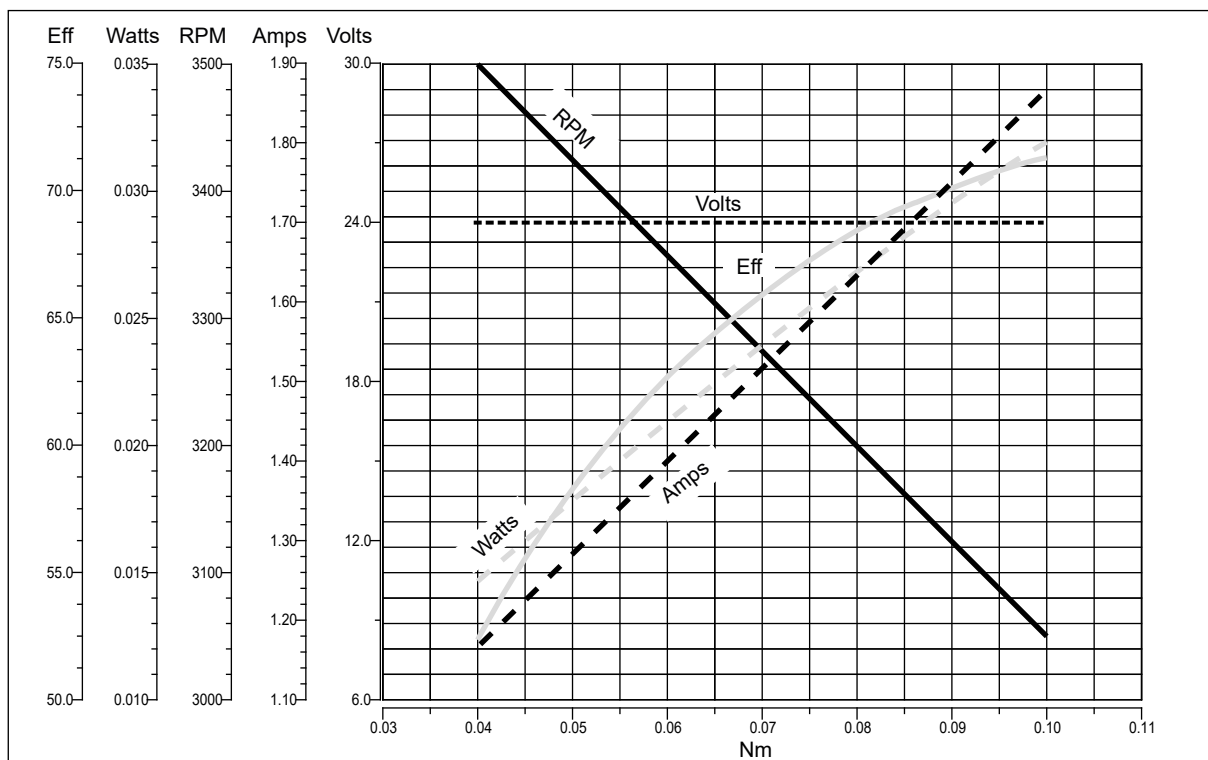

DC

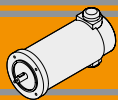
**EC**

Motori elettrici CC - Ferrite
DC Electric motors - Ferrite

MINI TECNO**EC035.120 - EC035.240****Caratteristiche****Features**

Costruzione	Tubolare, senza ventilazione
Grandezza	Ø 52 mm
Potenza	55 W S2 (35 W S1)
Magneti	2
Supporti	Cuscinetti a sfera
Fori di montaggio	4
Alimentazione	Bassa tensione, 12 o 24 Vcc
Spazzole	N° 2 interne di composto grafite-rame
Cavo di alimentazione	Lunghezza: 200 mm
Opzioni	Encoder magnetico max. 1 imp/giro, max.2 canali

Construction	Tubular, without fan
Size	Ø 52 mm
Power	55 W S2 (35 W S1)
Magnets	2
Bearings	Ball bearings
Mounting holes	4
Power supply	Low voltage, 12 or 24 Vdc
Brushes	2 inside brushes made of graphite/copper composite
Electric cable	Length: 200 mm
Options	Magnetic encoder max 1 ppr, Max. 2 channels

Tipo Type	S	Pn [W]	V [V]	I [A]	IC	FF	Mn [Nm]	n ₁ [min ⁻¹]	IP	Kg
EC035.120	S1	35	12	5.2	F	1	0.11	3000	20	0.8
	S2 9'	55		8.0			0.18			
EC035.240	S1	35	24	2.6	F	1	0.11		20	0.8
	S2 9'	55		4.0			0.18			

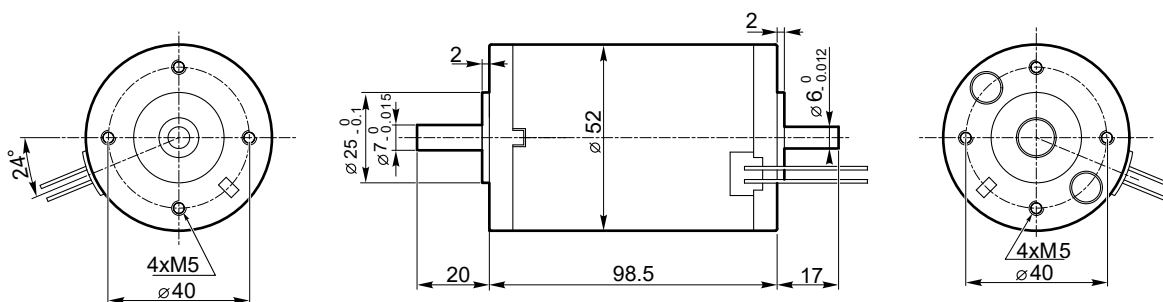
Dimensioni**Dimensions**

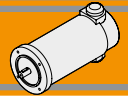

EC035.120 - EC035.240

Prestazioni

Performances

EC035.120

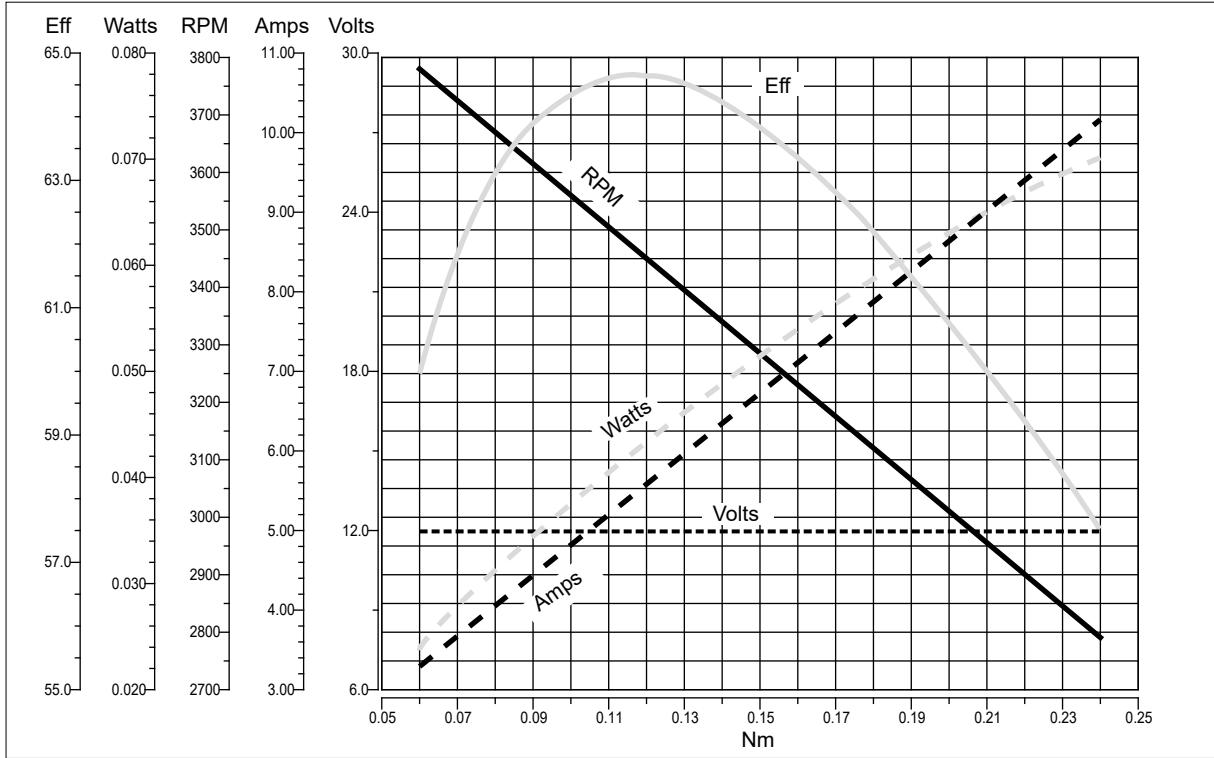

EC035.240

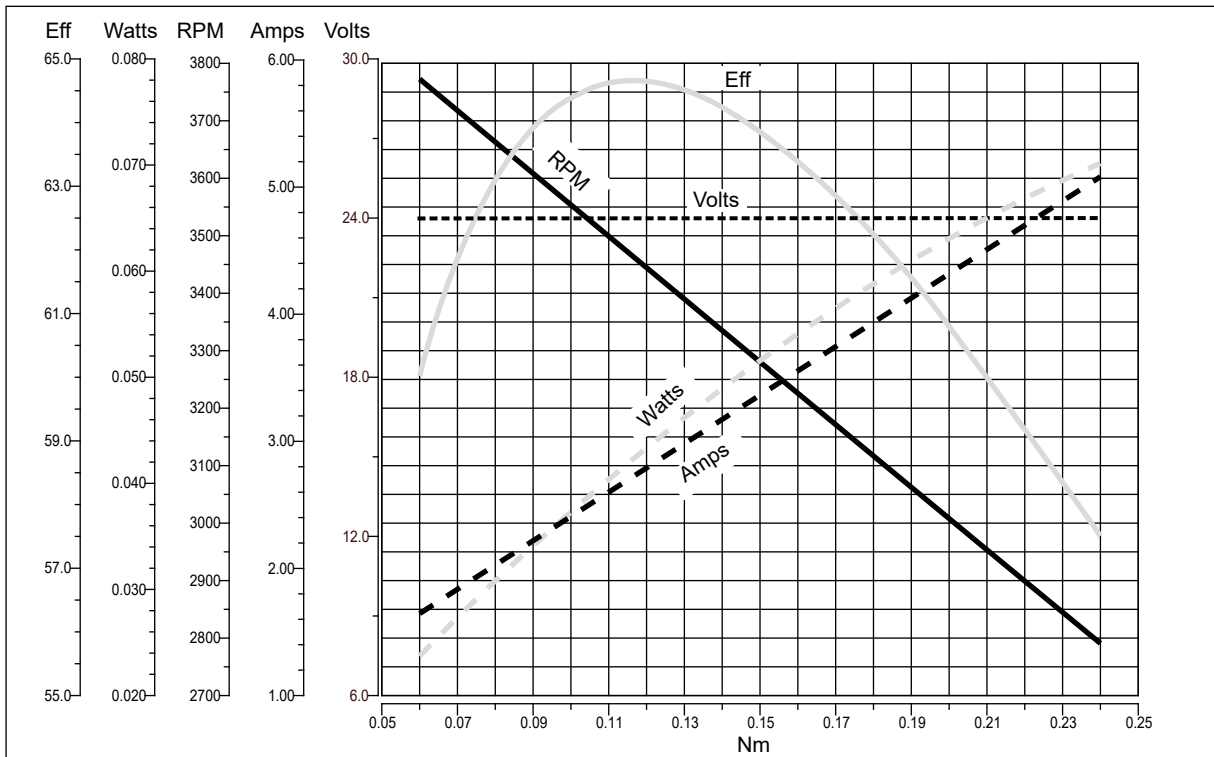

DC

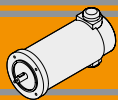

EC050.12E - EC050.24E

Caratteristiche

Features

Costruzione	Tubolare, senza ventilazione
Grandezza	Ø 65 mm
Potenza	70 W S2 (50 W S1)
Magneti	2
Supporti	Cuscinetti a sfera
Fori di montaggio	4
Alimentazione	Bassa tensione, 12 o 24 Vcc
Spazzole	N° 2 interne di composto grafite-rame
Cavo di alimentazione	Lunghezza: 200 mm
Bisporgenza	Standard

Construction	Tubular, without fan
Size	Ø 65 mm
Power	70 W S2 (50 W S1)
Magnets	2
Bearings	Ball bearings
Mounting holes	4
Power supply	Low voltage, 12 or 24 Vdc
Brushes	2 inside brushes made of graphite/copper composite
Electric cable	Length: 200 mm
Rear Shaft	Standard

Tipo Type	S	Pn [W]	V [V]	I [A]	IC	FF	Mn [Nm]	n ₁ [min ⁻¹]	IP	Kg
EC050.12E	S1	50	12	6.5	F	1	0.16	3000	20	1.2
	S2 30'	70		9.0			0.22			
EC050.24E	S1	50	24	3.2			0.16			
	S2 30'	70		4.5			0.22			

Dimensioni

Dimensions

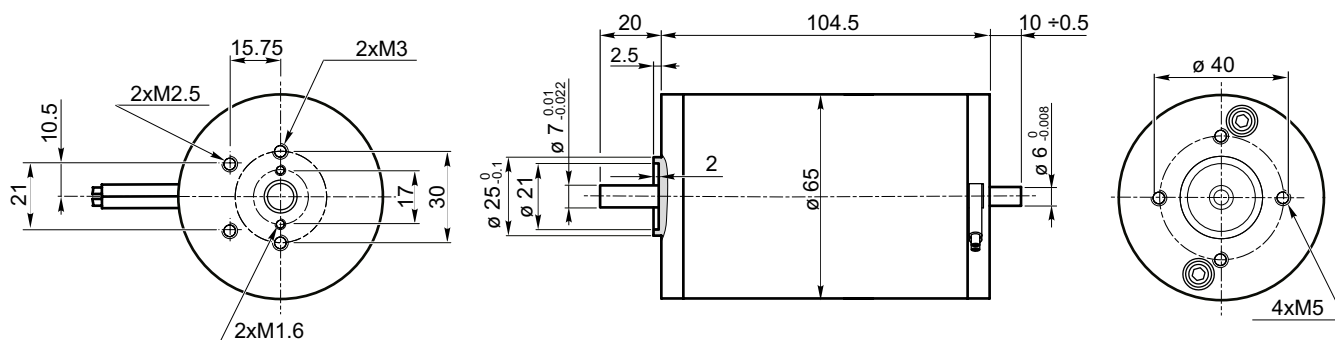

Freno / Brake → [BB23](#)

Encoder → [BB24](#)

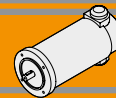

EC050.12E - EC050.24E

Prestazioni

Performances

EC050.12E

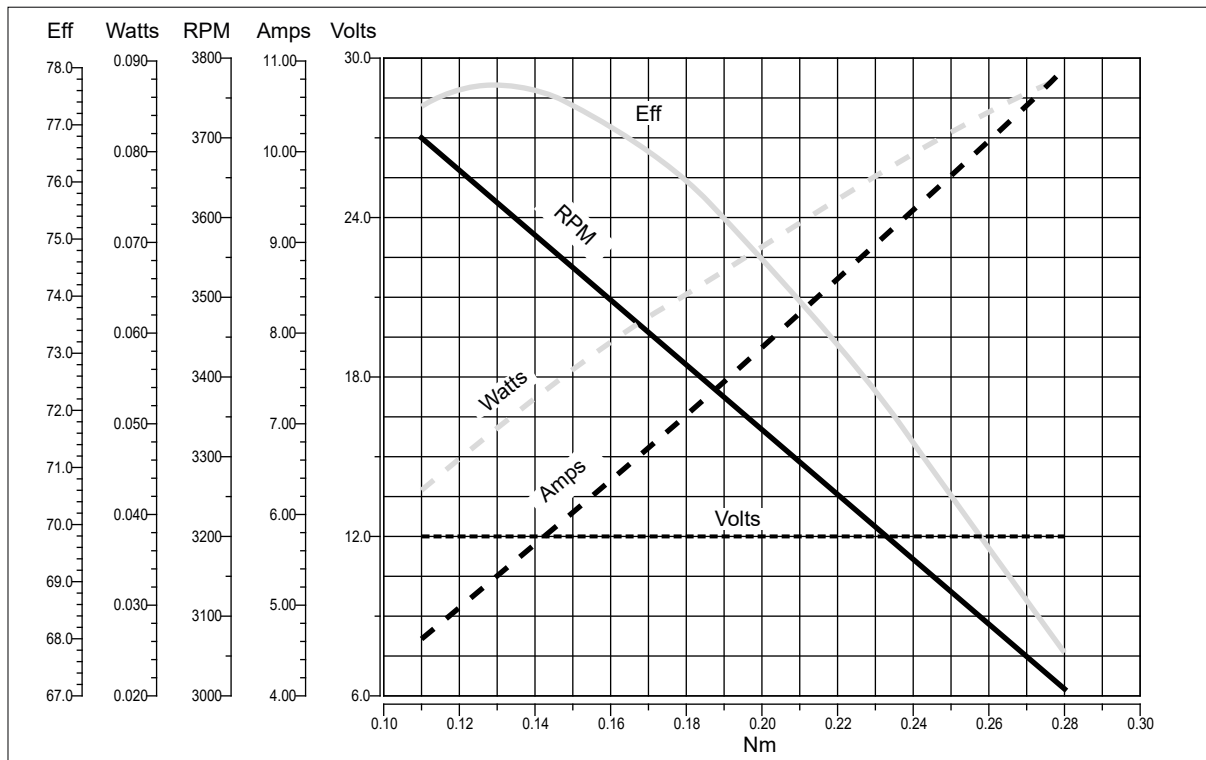

EC050.24E

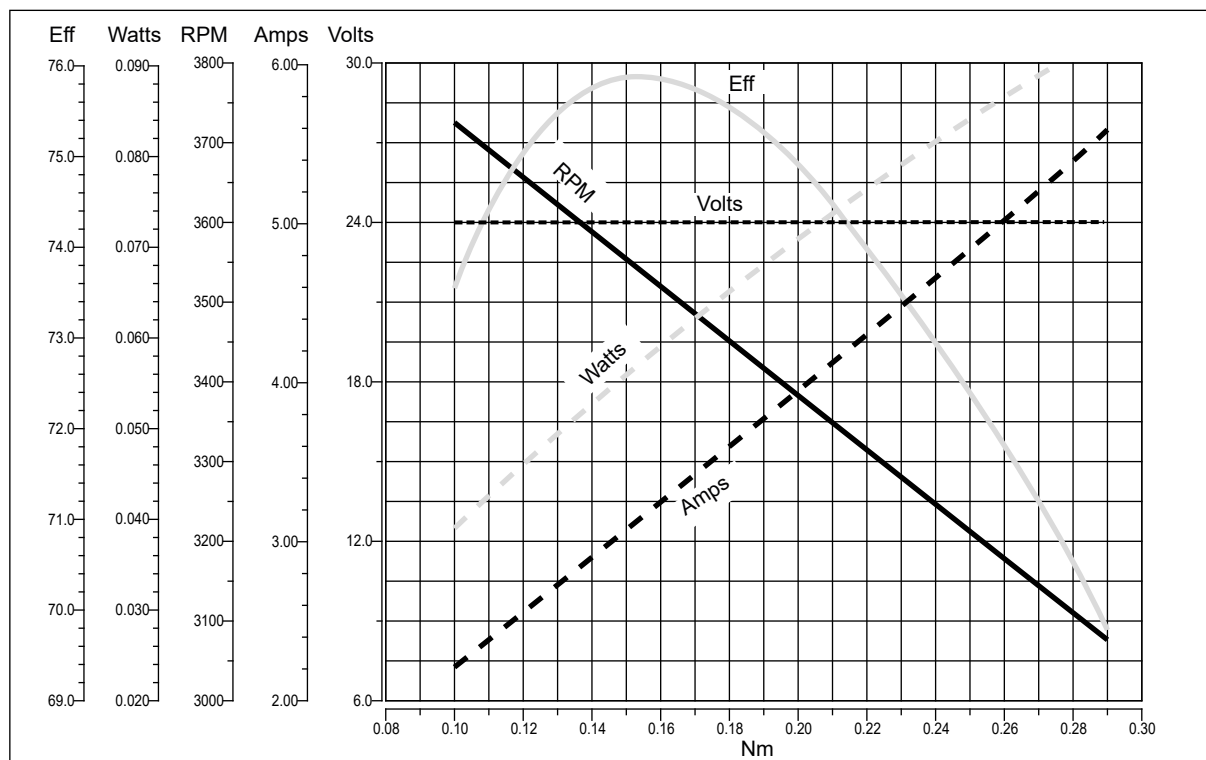

DC

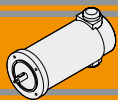

EC070.12E - EC070.24E

Caratteristiche

Features

Costruzione	Tubolare, senza ventilazione
Grandezza	Ø 65 mm
Potenza	100 W S2
Magneti	2
Supporti	Cuscinetti a sfera
Fori di montaggio	4
Alimentazione	Bassa tensione, 12 o 24 Vcc
Spazzole	N° 2 interne di composto grafite-rame
Cavo di alimentazione	Lunghezza: 1000 mm

Construction	Tubular, without fan
Size	Ø 65 mm
Power	100 W S2
Magnets	2
Bearings	Ball bearings
Mounting holes	4
Power supply	Low voltage, 12 or 24 Vdc
Brushes	2 inside brushes made of graphite/copper composite
Electric cable	Length: 1000 mm

Tipo Type	S	Pn [W]	V [V]	I [A]	IC	FF	Mn [Nm]	n ₁ [min ⁻¹]	IP	Kg
EC070.12E	S1	70	12	8.4	F	1	0.22	3000	20	1.7
	S2 30'	100		11.8			0.31			
EC070.24E	S1	70	24	4.2			0.22			
	S2 30'	100		5.9			0.31			

Dimensioni

Dimensions

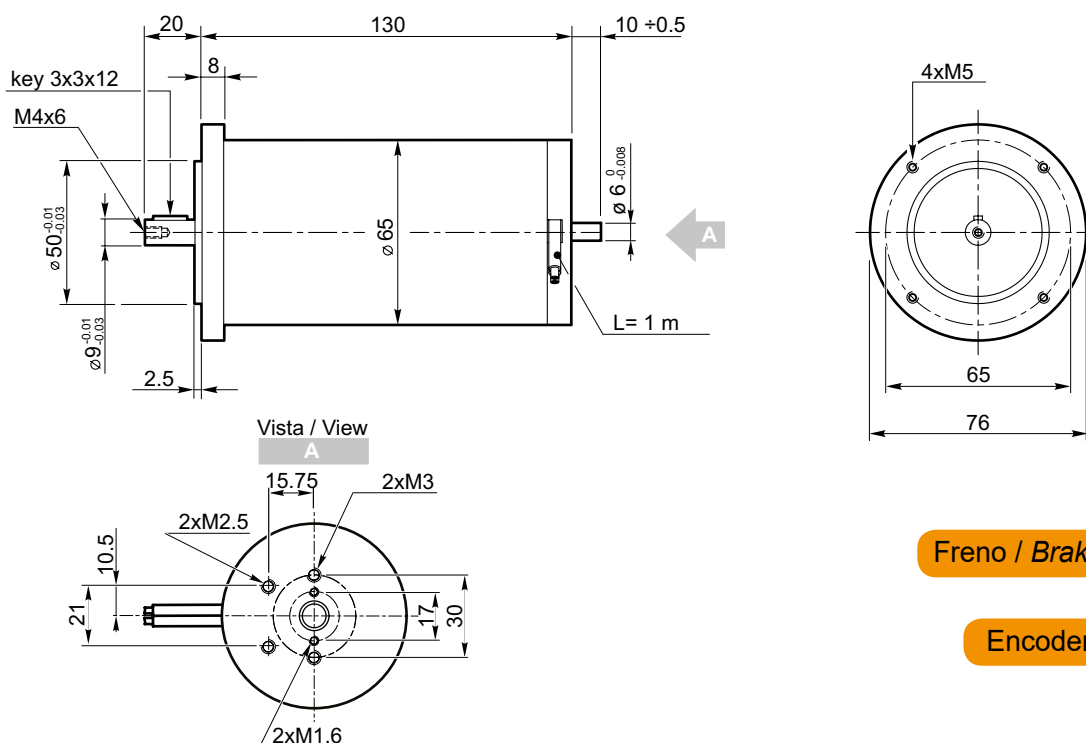

- Freno / Brake → BB23
- Encoder → BB24

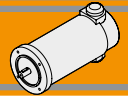

EC070.12E - EC070.24E

Prestazioni

Performances

EC070.12E

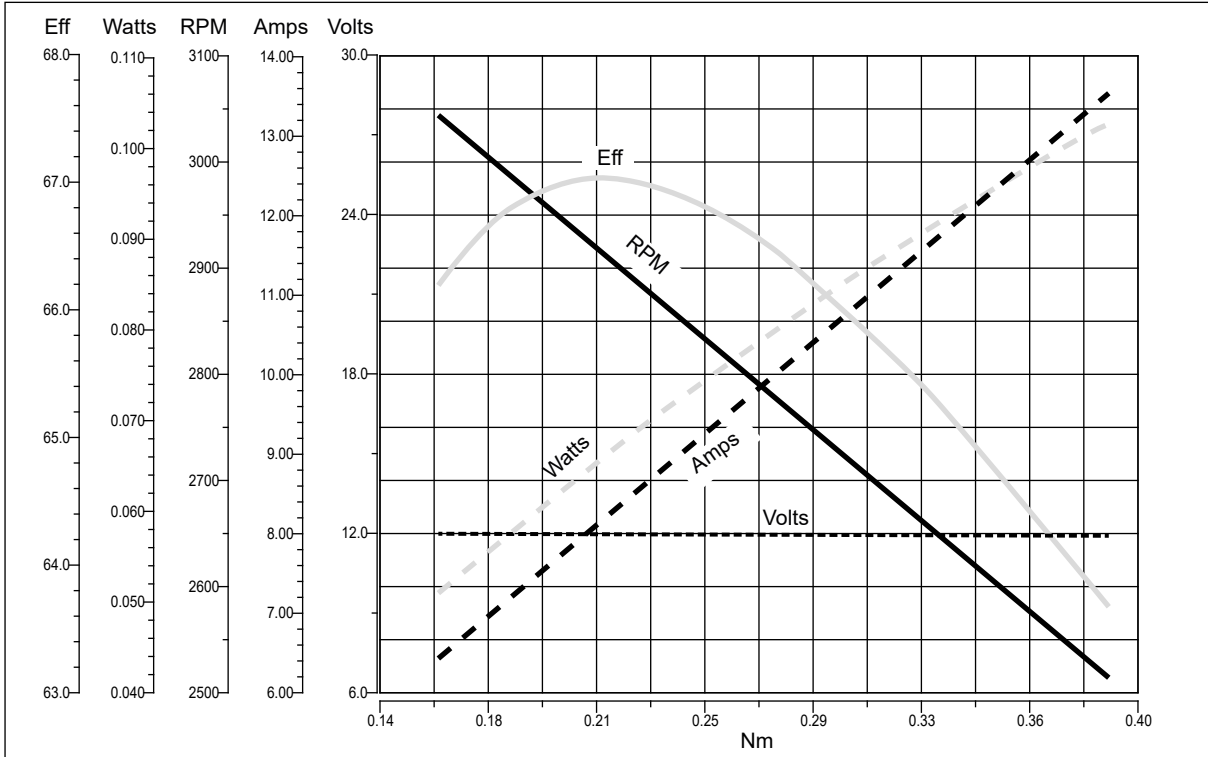

EC070.24E

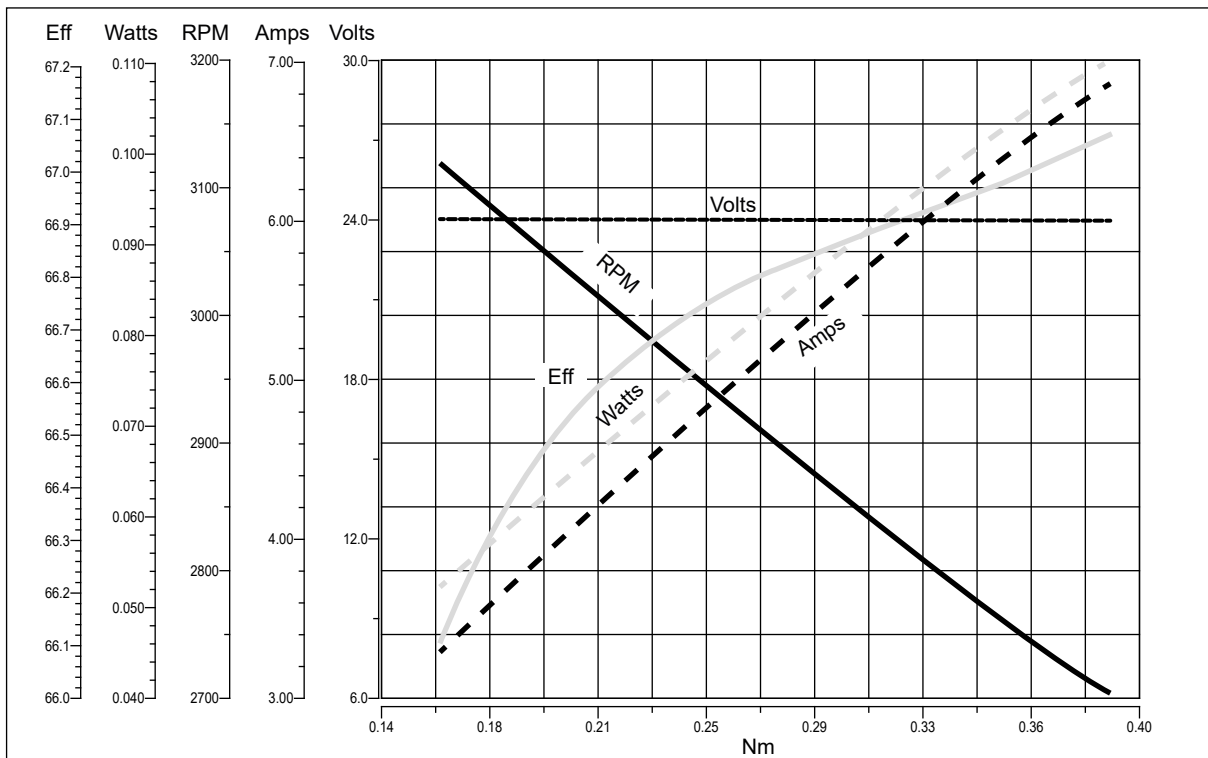

DC

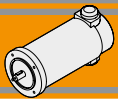

EC100.120 - EC100.240 - EC100.24E

Caratteristiche

Features

Costruzione	Tubolare, senza ventilazione
Grandezza	Ø 80 mm
Potenza	140 W S2 (100 W S1)
Magneti	2
Supporti	Cuscinetti a sfera
Fori di montaggio	4
Alimentazione	Bassa tensione, 12 o 24 Vcc
Spazzole	N° 2 di composto grafite-rame
Dimensione spazzole	LxPxH = 17.1 x 6.5 x 16.7 mm
Cavo di alimentazione	Lunghezza: 1000 mm
Bisporgenza	Standard solo EC100.24E

Construction	Tubular, without fan
Size	Ø 80 mm
Power	140 W S2 (100 W S1)
Magnets	2
Bearings	Ball bearings
Mounting holes	4
Power supply	Low voltage, 12 or 24 Vdc
Brushes	2 inside brushes made of graphite/copper composite
Brushes size	LxWxH = 17.1 x 6.5 x 16.7 mm
Electric cable	Length: 1000 mm
Rear shaft	Standard only EC100.24E

Tipo Type	S	Pn [W]	V [V]	I [A]	IC	FF	Mn [Nm]	n ₁ [min ⁻¹]	IP	Kg
EC100.120	S1	100	12	12	F	1	0.31	3000	40	2.7
	S2 25'	140		16.8			0.43			
EC100.240	S1	100	24	6			0.31			
	S2 25'	140		8.4			0.43			
EC100.24E	S1	100	24	6			0.31		20	
	S2 25'	140		8.4			0.43			

Dimensioni

Dimensions

**EC100.120
EC100.240**

56 B14	
L	153
D	80
S	65
C (-0.03 / -0.01)	50
63B14*	
L	155
D	90
S	75
C (-0.03 / -0.01)	60

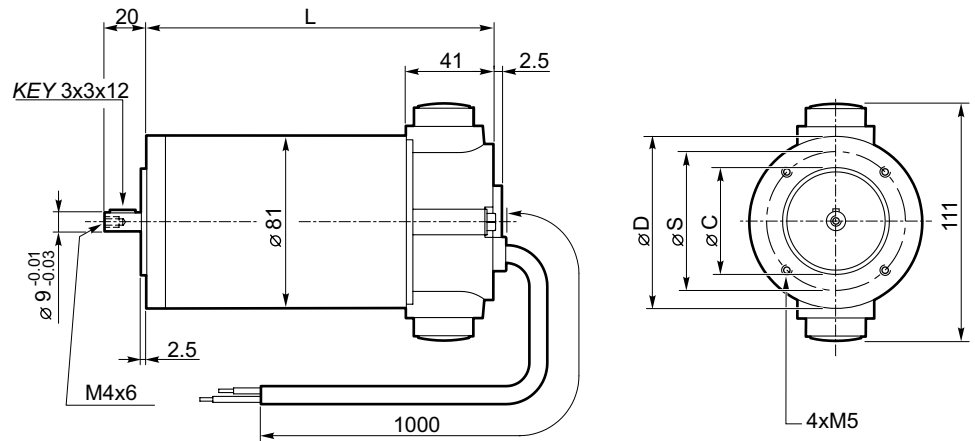

* Usare boccola 9/11
* Use sleeve 9/11

Freno / Brake

BB23

Encoder

BB24

EC100.24E

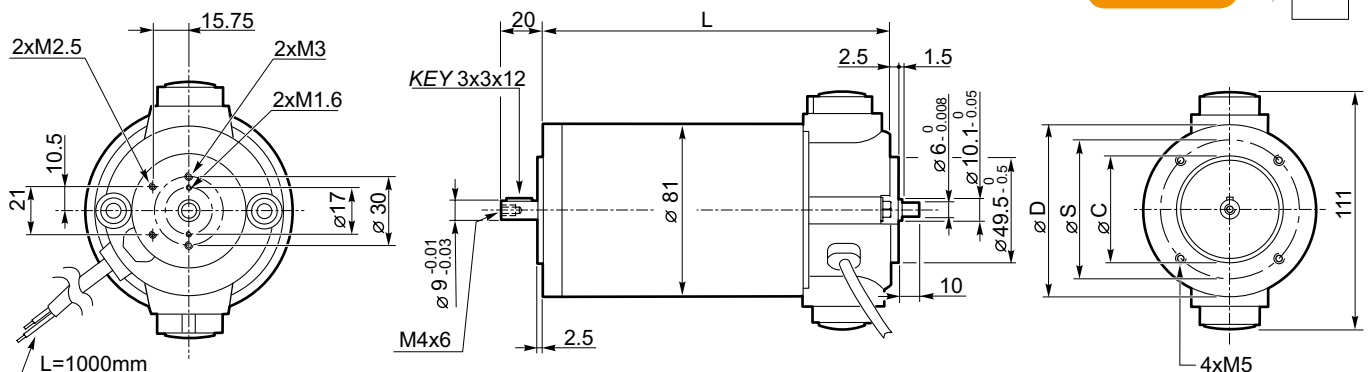

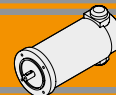

EC100.120 - EC100.240 - EC100.24E

Prestazioni

Performances

EC100.120

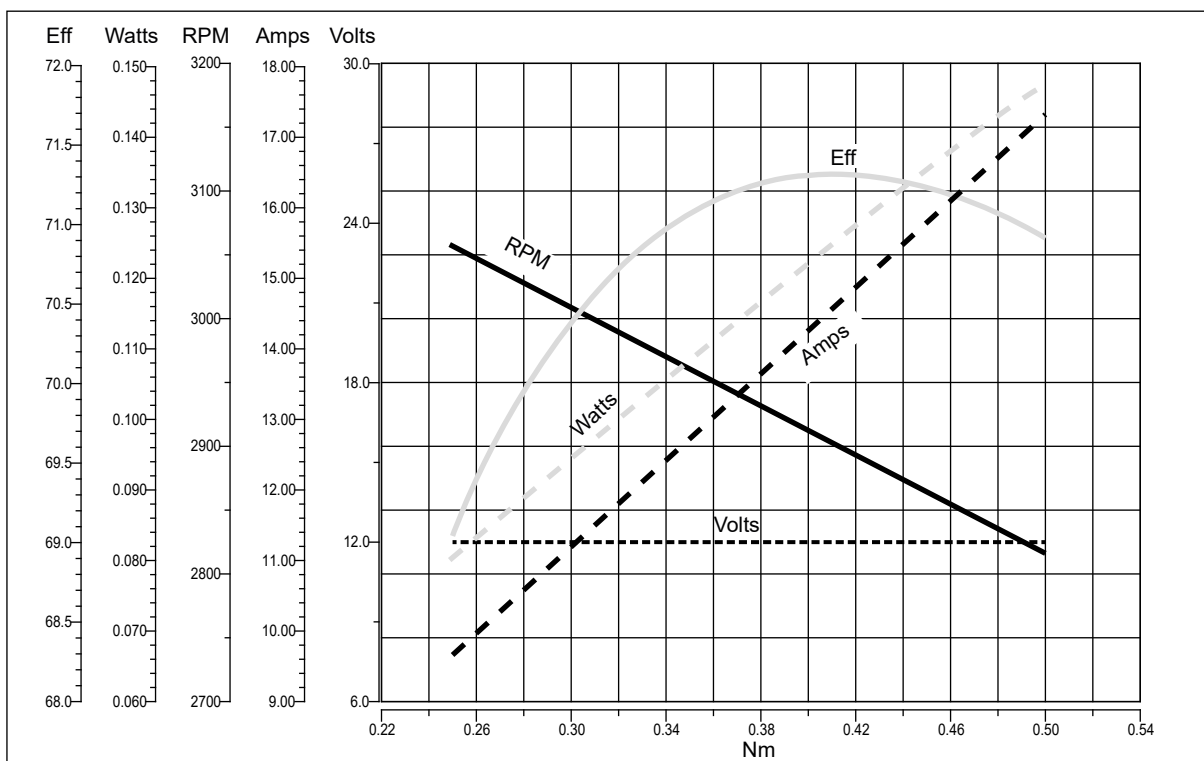

EC100.240 - EC100.24E

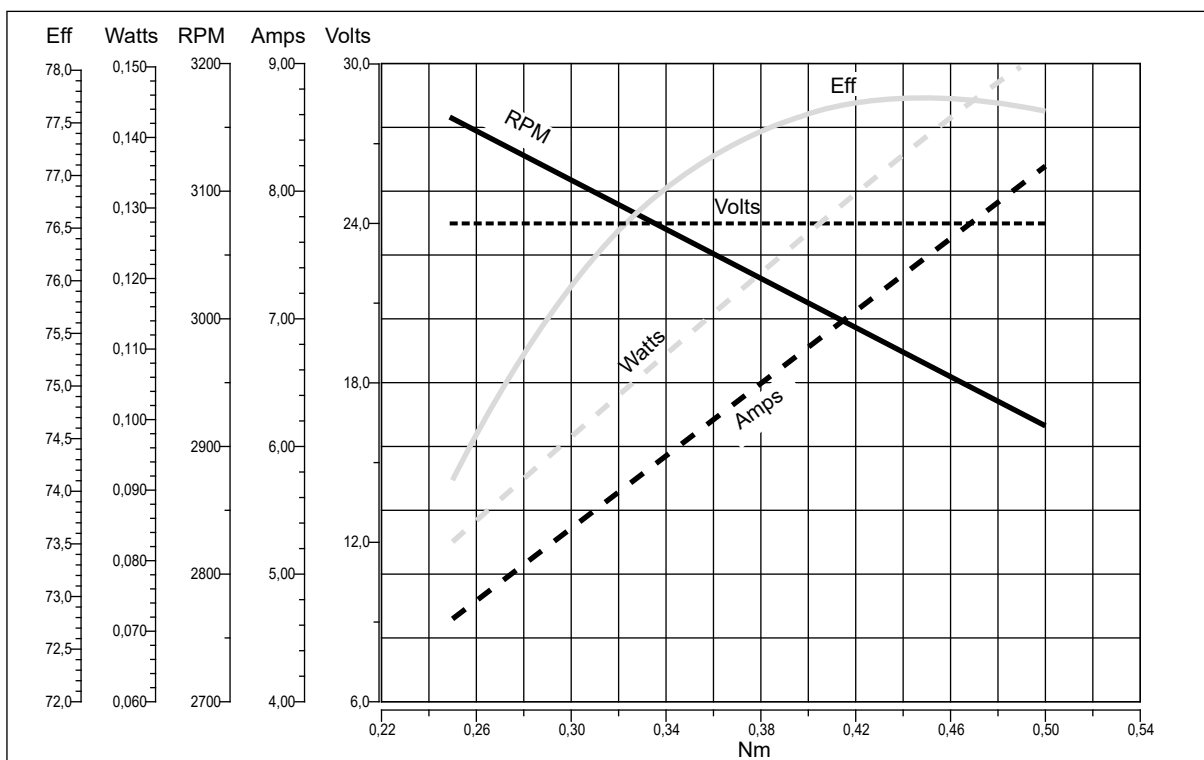

DC

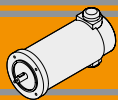

EC180.120 - EC180.240 - EC180.24E

Caratteristiche

Features

Costruzione	Tubolare, senza ventilazione
Grandezza	Ø 80 mm
Potenza	250 W S2 (180 W S1)
Magneti	2
Supporti	Cuscinetti a sfera
Fori di montaggio	4
Alimentazione	Bassa tensione, 12 o 24 Vcc
Spazzole	N° 2 di composto grafite-rame
Dimensione spazzole	LxPxH = 17.1 x 6.5 x 16.7 mm
Cavo di alimentazione	Lunghezza: 1000 mm
Bisporgenza	Standard solo EC180.24E

Construction	Tubular, without fan
Size	Ø 80 mm
Power	250 W S2 (180 W S1)
Magnets	2
Bearings	Ball bearings
Mounting holes	4
Power supply	Low voltage, 12 or 24 Vdc
Brushes	2 inside brushes made of graphite/copper composite
Brushes size	LxPxH = 17.1 x 6.5 x 16.7 mm
Electric cable	Length: 1000 mm
Rear shaft	Standard only EC180.24E

Tipo Type	S	Pn [W]	V [V]	I [A]	IC	FF	Mn [Nm]	n ₁ [min ⁻¹]	IP	Kg
EC180.120	S1	180	12	21.5	F	1	0.57	3000	40	3.4
	S2 25'	250		30			0.8			
EC180.240	S1	180	24	10.8			0.57			
	S2 25'	250		15			0.8			
EC180.24E	S1	180		10.8			0.57		20	
	S2 25'	250		15			0.8			

Dimensioni

Dimensions

**EC180.120
EC180.240**

56 B14	
L	185
D	80
S	65
C (-0.03 / -0.01)	50
63B14*	
L	187
D	90
S	75
C (-0.03 / -0.01)	60

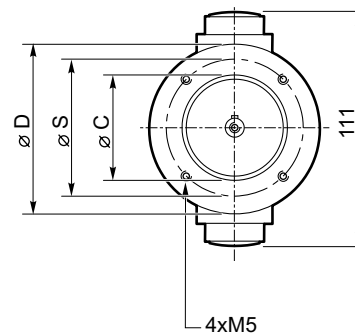
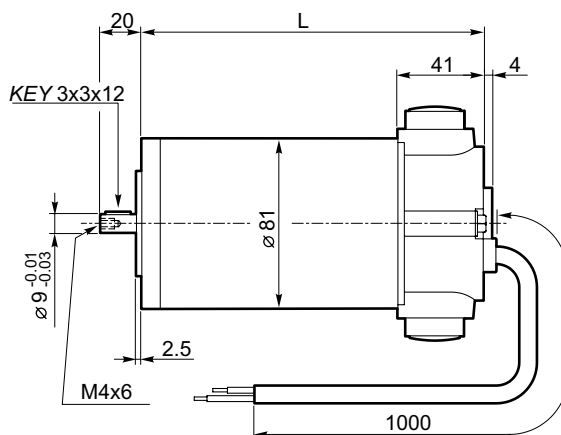

* Usare boccola 9/11
* Use sleeve 9/11

Freno / Brake → BB23

Encoder → BB24

EC180.24E

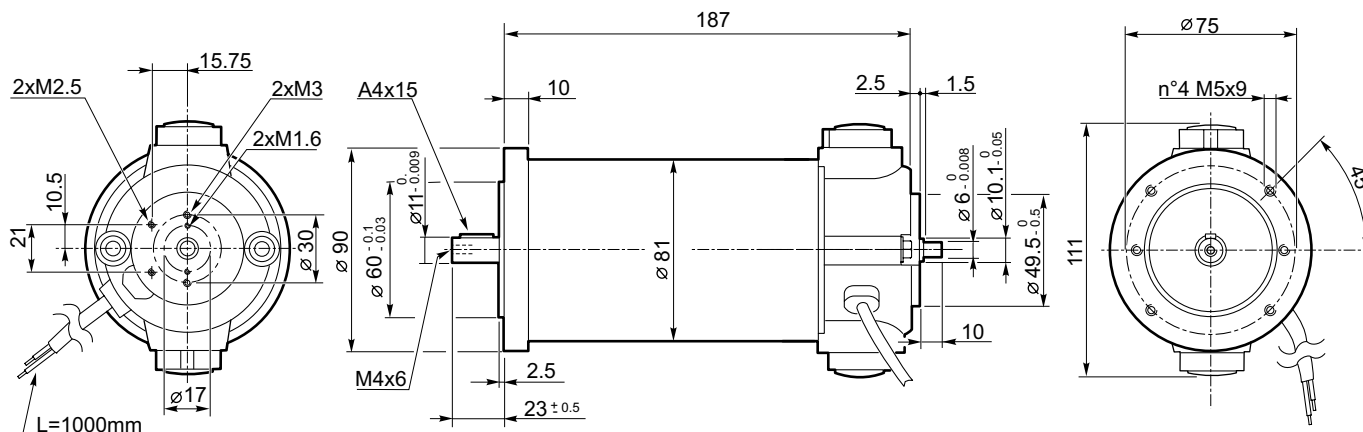

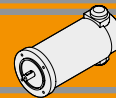

EC180.120 - EC180.240 - EC180.24E

Prestazioni

Performances

EC180.120

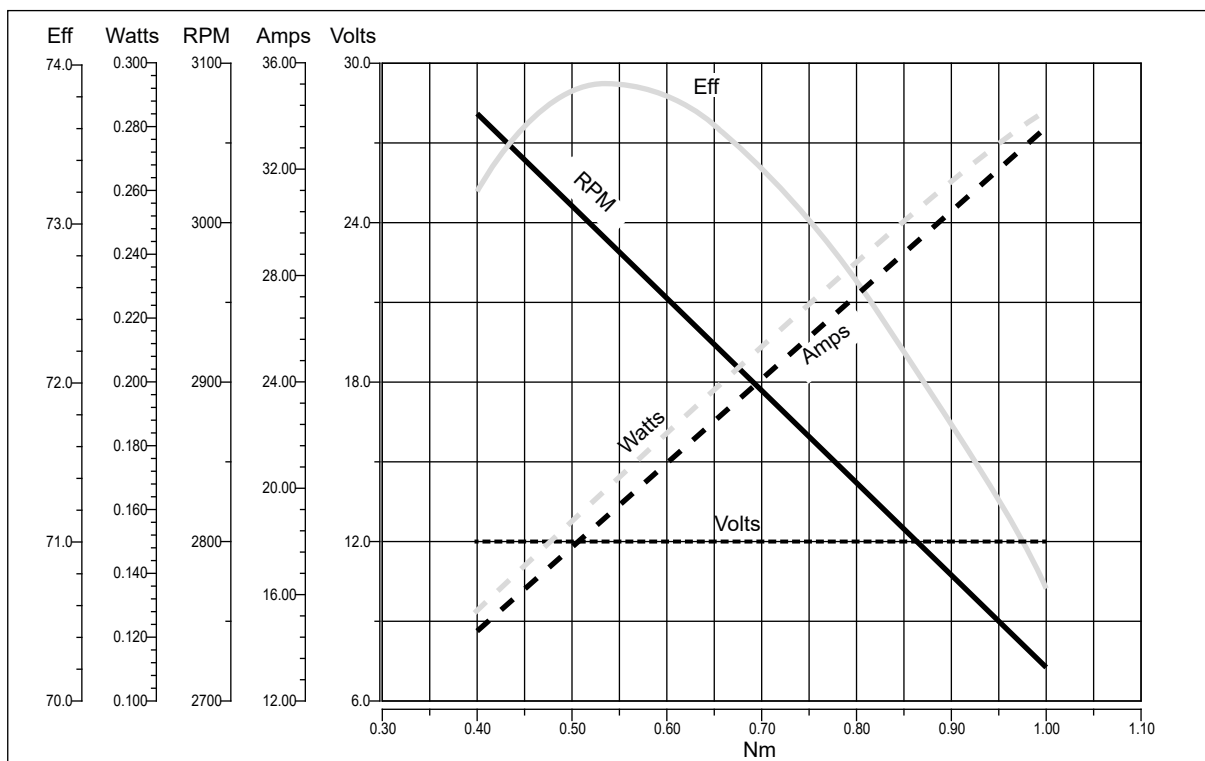

EC180.240 - EC180.24E

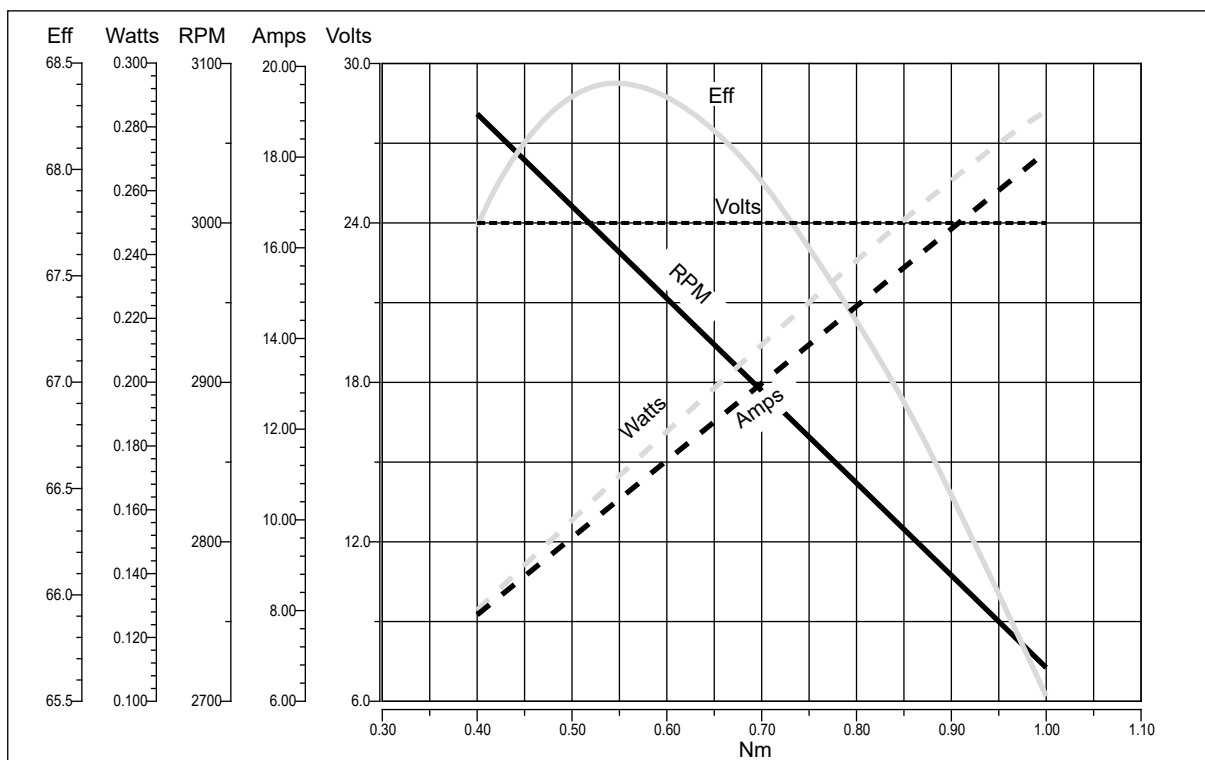

DC

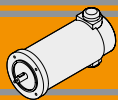

EC250.120 - EC250.240

Caratteristiche

Features

Costruzione	Tubolare, senza ventilazione
Grandezza	Ø 104 mm
Potenza	350 W S2 (250 W S1)
Magneti	4
Supporti	Cuscinetti a sfera
Fori di montaggio	8
Alimentazione	Bassa tensione, 12 o 24 Vcc
Spazzole	N° 4 di composto grafite-rame
Dimensione spazzole	LxPxH = 18.9 x 9.5 x 16.7 mm
Terminali	2 con doppio dado di fissaggio

Construction	Tubular, without fan
Size	Ø 104 mm
Power	350 W S2 (250 W S1)
Magnets	4
Bearings	Ball bearings
Mounting holes	8
Power supply	Low voltage, 12 or 24 Vdc
Brushes	4 inside brushes made of graphite/copper composite
Brushes size	LxPxH = 18.9 x 9.5 x 16.7 mm
Leads terminals	2, with double nut

Tipo Type	S	Pn [W]	V [V]	I [A]	IC	FF	Mn [Nm]	n ₁ [min ⁻¹]	IP	Kg
EC250.120	S1	250	12	30	F	1	0.8	3000	40	4.15
	S2 25'	350		38.5			1.12			
EC250.240	S1	250	24	15			0.8			
	S2 25'	350		20.5			1.12			

Dimensioni

Dimensions

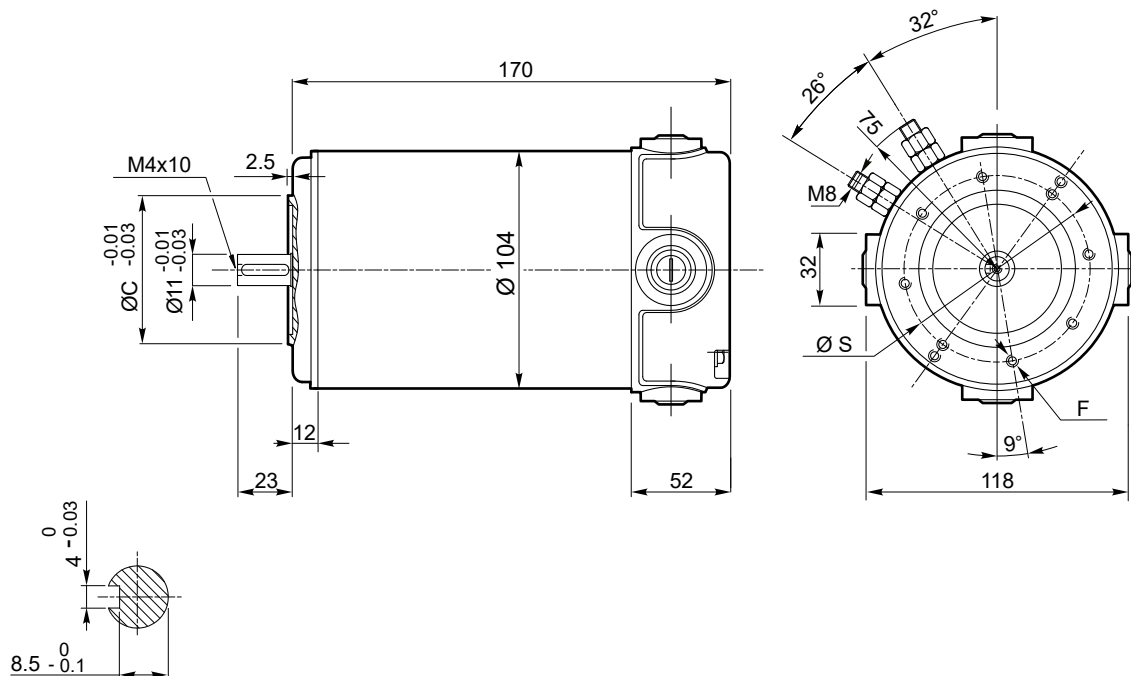

	63 B14	71 B14*
S	75	85
C (-0.03 / -0.01)	60	70
F	8 - M5	8 - M6

* Usare boccola 11/14
* Use sleeve 11/14

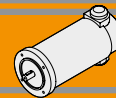

EC250.120 - EC250.240

Prestazioni

Performances

EC250.120

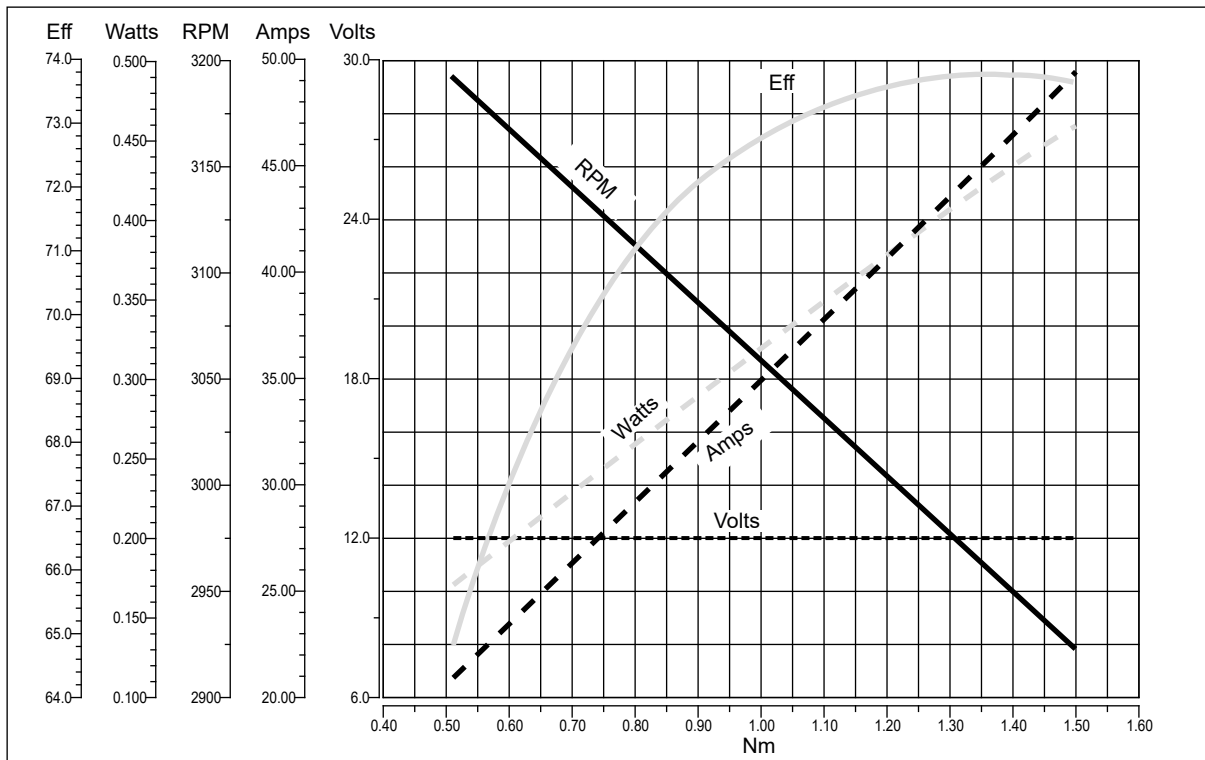

EC250.240

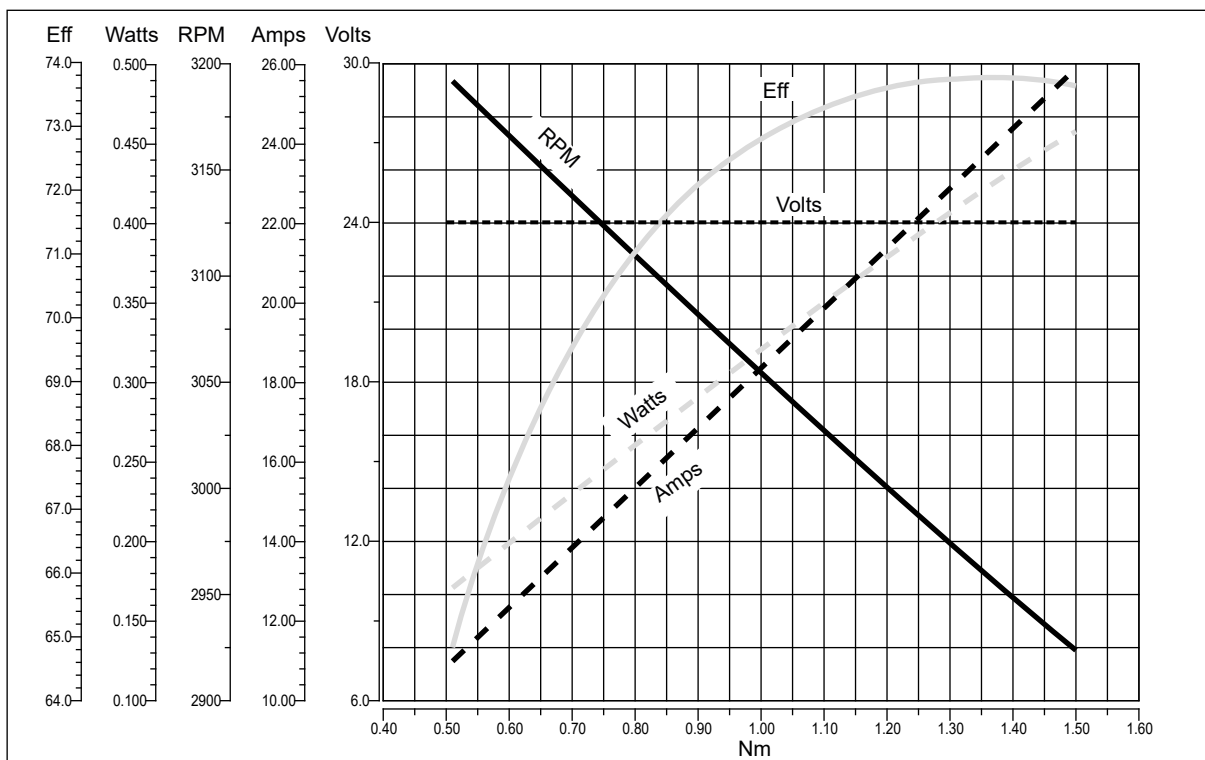

DC

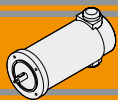

EC350.120 - EC350.240

Caratteristiche

Features

Costruzione	Tubolare, senza ventilazione
Grandezza	Ø 110 mm
Potenza	500 W S2 (350 W S1)
Magneti	4
Supporti	Cuscinetti a sfera
Fori di montaggio	8
Alimentazione	Bassa tensione, 12 o 24 Vcc
Spazzole	N° 4 di composto grafite-rame
Dimensione spazzole	LxPxH = 18.9 x 9.5 x 16.7 mm
Terminali	2 con dadi di fissaggio
Freno	Elettromagnetico

Construction	Tubular, without fan
Size	Ø 110 mm
Power	500 W S2 (350 W S1)
Magnets	4
Bearings	Ball bearings
Mounting holes	8
Power supply	Low voltage, 12 or 24 Vdc
Brushes	4 brushes made of graphite/copper composite
Brushes size	LxPxH = 18.9 x 9.5 x 16.7 mm
Leads terminals	2, with double nut
Brake	Electromagnetic

Tipo Type	S	Pn [W]	V [V]	I [A]	IC	FF	Mn [Nm]	n ₁ [min ⁻¹]	IP	Kg
EC350.120	S1	350	12	42	F	1	1.12	3000	40	5.1
	S2 30'	500		58.8			1.57			
EC350.240	S1	350	24	21			1.12		40	5.3
	S2 30'	500		29.4			1.57			

Dimensioni

Dimensions

63 B14 - 71 B14

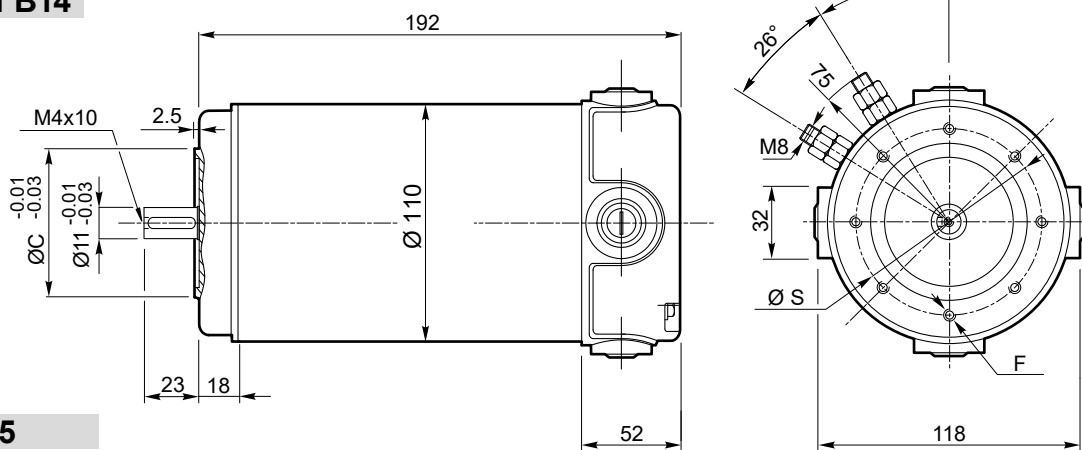

71 B5

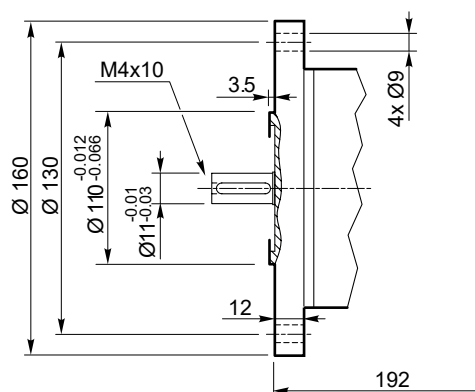

Freno / Brake

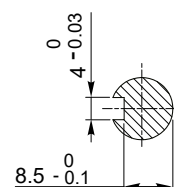

	63 B14	71 B14*
S	75	85
C (-0.03 / -0.01)	60	70
F	8 - M5	8 - M6

* Usare boccola 11/14
* Use sleeve 11/14

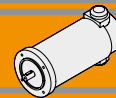

EC350.120 - EC350.240

Prestazioni

Performances

EC350.120

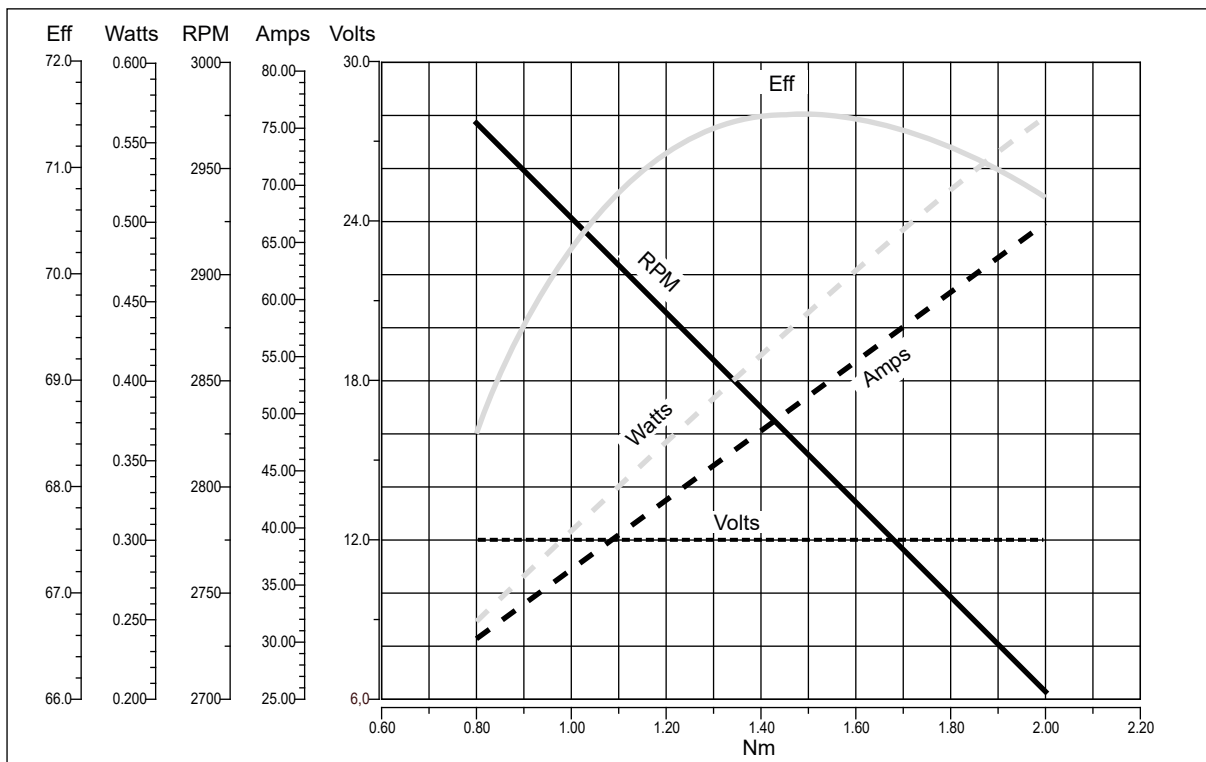

EC350.240

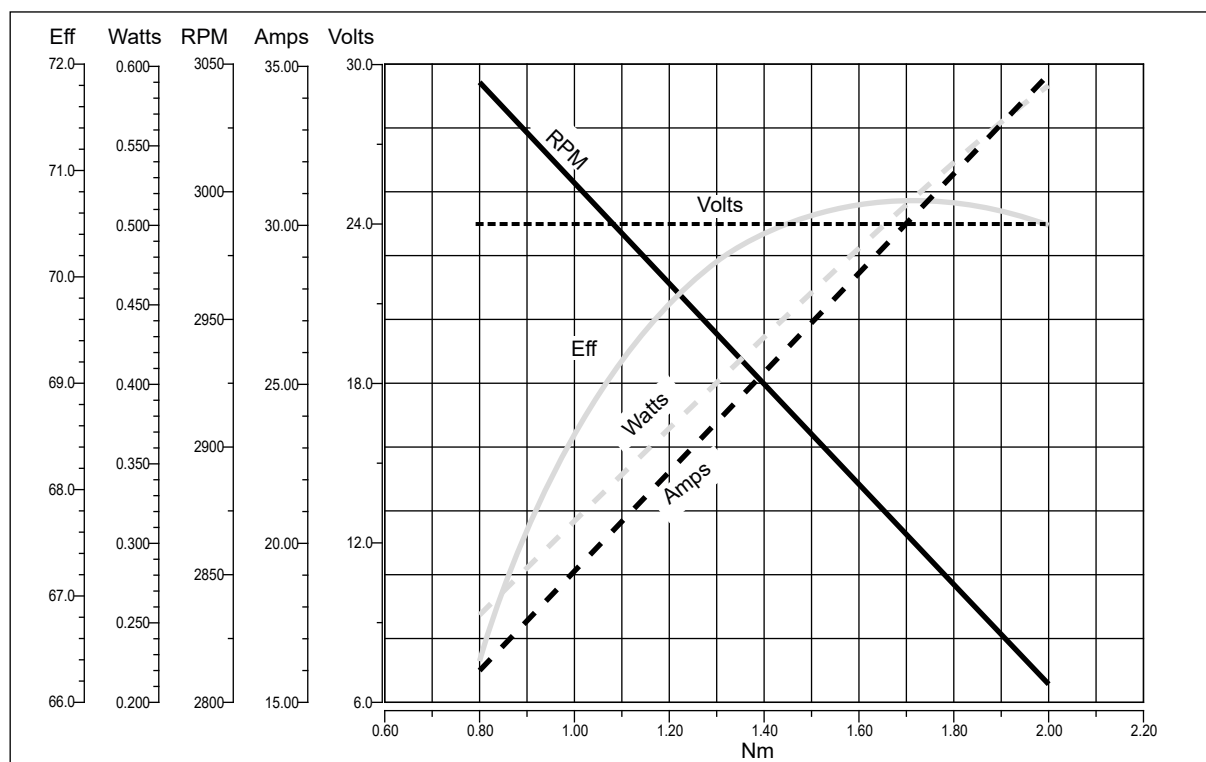

DC

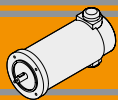

EC600.120 - EC600.240

Caratteristiche

Features

Costruzione	Tubolare, senza ventilazione
Grandezza	Ø 110 mm
Potenza	800 W S2 (600 W S1)
Magneti	4
Supporti	Cuscinetti a sfera
Fori di montaggio	8
Alimentazione	Bassa tensione, 12 o 24 Vcc
Spazzole	N° 4 di composto grafite-rame
Dimensione spazzole	LxPxH = 18.9 x 9.5 x 16.7 mm
Terminali	2 con doppio dado di fissaggio
Freno	Elettromagnetico

Construction	Tubular, without fan
Size	Ø 110 mm
Power	800 W S2 (600 W S1)
Magnets	4
Bearings	Ball bearings
Mounting holes	8
Power supply	Low voltage, 12 or 24 Vdc
Brushes	4 brushes made of graphite/copper composite
Brushes size	LxPxH = 18.9 x 9.5 x 16.7 mm
Leads terminals	2, with double nut
Brake	Electromagnetic

Tipo Type	S	Pn [W]	V [V]	I [A]	IC	FF	Mn [Nm]	n ₁ [min ⁻¹]	IP	Kg
EC600.120	S1	600	12	71	F	1	1.91	3000	40	6.6
	S2 30'	800		94.4			2.54			
EC600.240	S1	600	24	35.5			1.91		40	7.1
	S2 30'	800		47.2			2.54			

Dimensioni

Dimensions

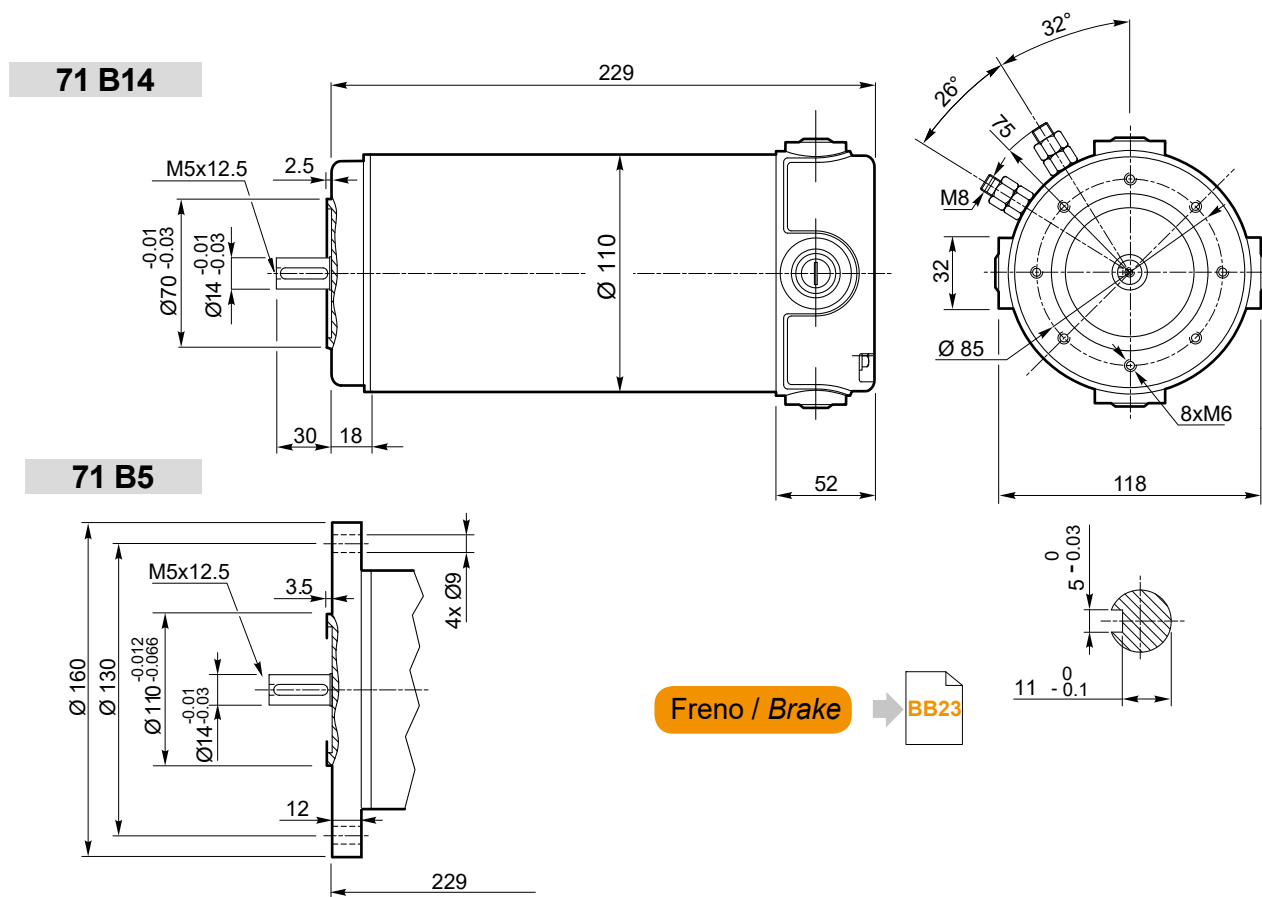

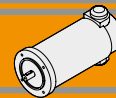

EC600.120 - EC600.240

Prestazioni

Performances

EC600.120

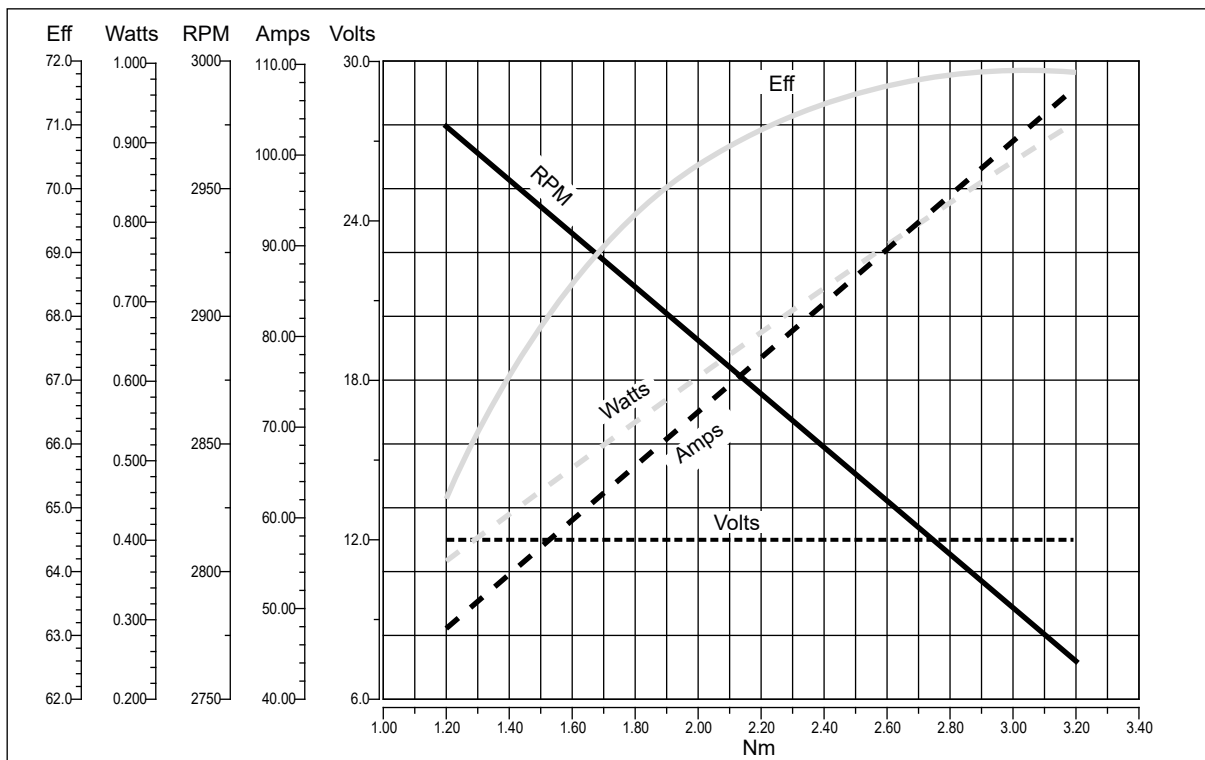

EC600.240

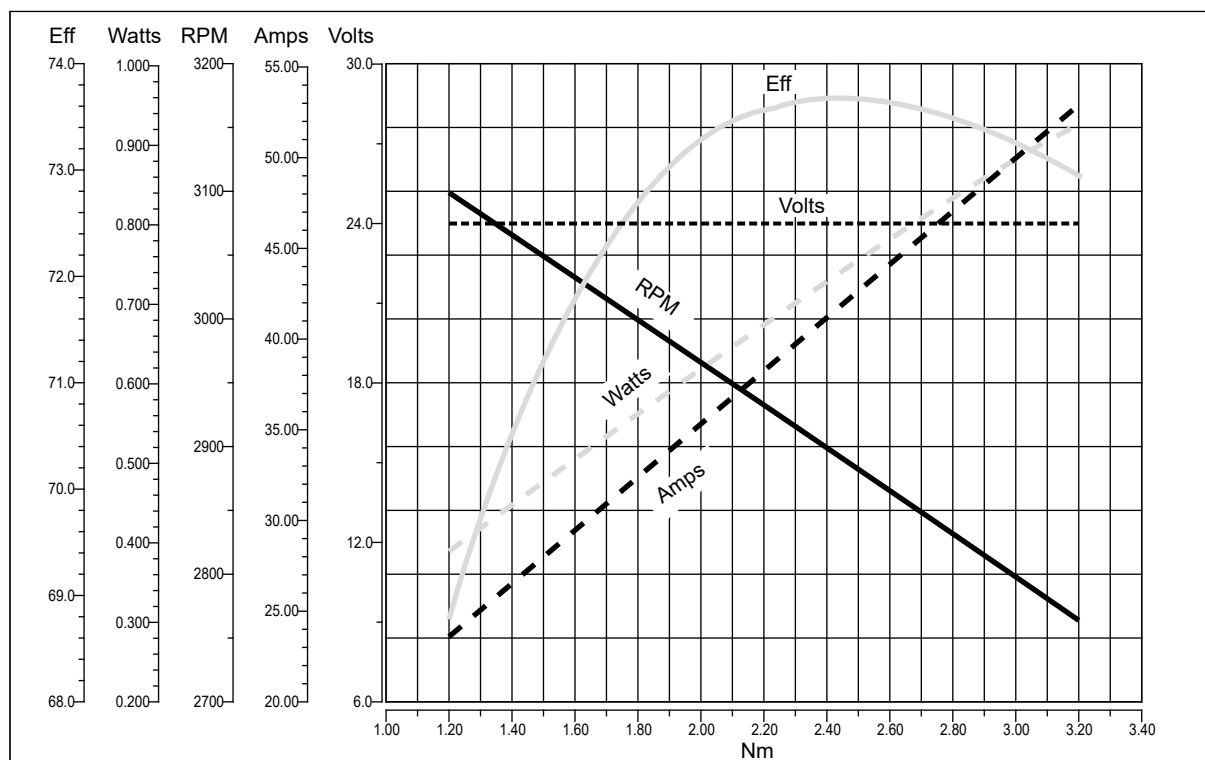

DC

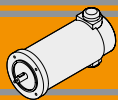

Legenda / Glossario dei grafici

Key / Diagram Glossary

Dato un motore in C.C, la velocità di rotazione è funzione lineare della coppia; così pure la corrente assorbita è una funzione lineare della coppia. Velocità e corrente variano in maniera sensibile al variare del carico.

With a D.C. motor, the rotational speed is a linear function of the torque. In the same way, the absorbed current is also a linear function of the torque. Speed and current change a lot against applied torque.

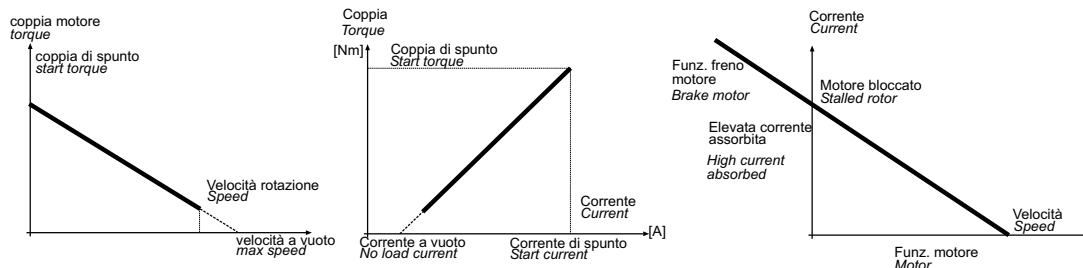

La potenza utile (potenza all' albero) si ricava dalla formula:

$$P_n [W] = M_n \cdot S = \frac{2\pi}{60} \cdot n_1 \cdot M_n$$

The output power is calculated using the formula:

$$P_n [W] = M_n \cdot S = \frac{2\pi}{60} \cdot n_1 \cdot M_n$$

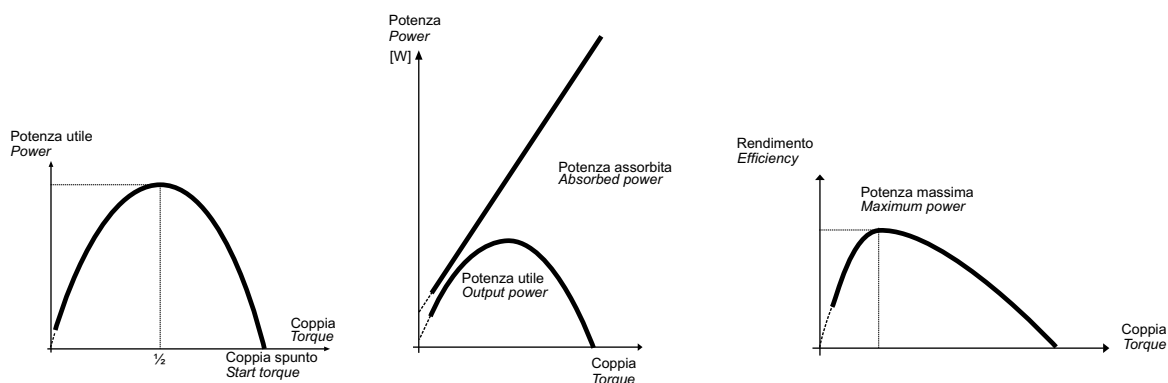

Poiché la tensione di alimentazione è costante mentre la corrente è linearmente crescente al crescere della coppia, l'andamento della potenza assorbita è un retta crescente. Dal rapporto tra la potenza meccanica e la potenza assorbita si ottiene il grafico dell'efficienza.

Since the supply voltage is constant, whereas the current increases in a linear manner as the torque increases, the absorbed power trend is a straight line going up. Efficiency is shown from the ratio between the output power and the absorbed power.

Formule utili

Useful formulas

$$\eta = \frac{P_n}{P_a}$$

$$P_a = V \cdot I$$

$$P_n = V \cdot I \cdot \eta$$

$$P_n = M_n \cdot S_v$$

$$S_v = \frac{n_1}{9.55}$$

$$[HP] \cdot 746 = [W].$$

Esempio 2 HP = circa 1500 W.

$$\eta = \frac{P_n}{P_a}$$

$$P_a = V \cdot I$$

$$P_n = V \cdot I \cdot \eta$$

$$P_n = M_n \cdot S_v$$

$$S_v = \frac{n_1}{9.55}$$

$$[HP] \cdot 746 = [W].$$

Example 2 HP = approx. 1500 W.

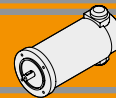

Freno

Brake

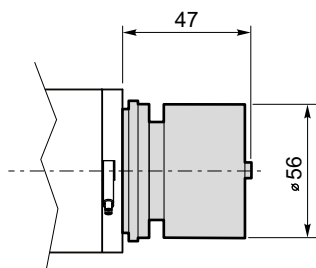
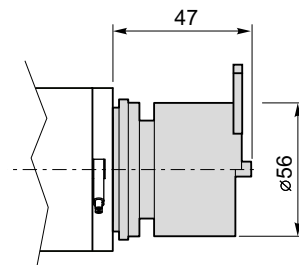
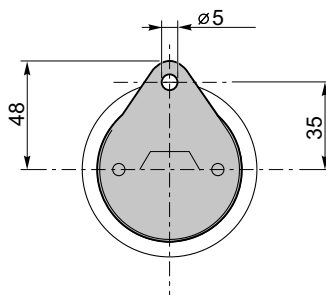
Freno / Brake
**EC050...BR
EC070...BR**

Freno con leva di sblocco/ Brake with hand release
**EC050...BRL
EC070...BRL**

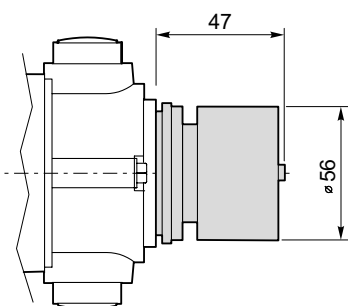
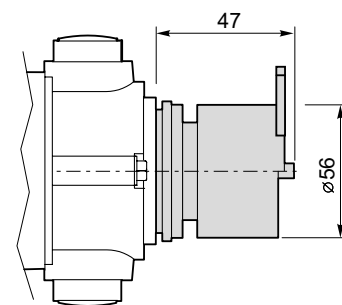
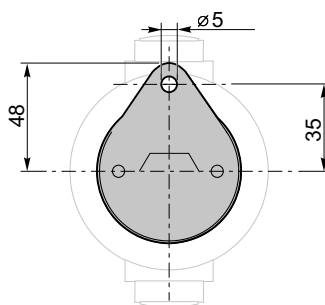
	P_n [W]	V [V]	M_n [Nm]	n₁ [min ⁻¹]
Caratteristiche del freno / Break features	14	12 24	2	3000

**EC100.24E BR
EC180.24E BR**

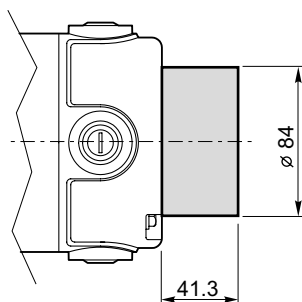
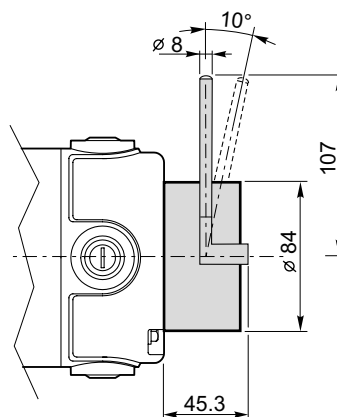
**EC100.24E BRL
EC180.24E BRL**

	P_n [W]	V [V]	M_n [Nm]	n₁ [min ⁻¹]
Caratteristiche del freno / Break features	14	12 24	2	3000

**EC350...BR
EC600...BR**

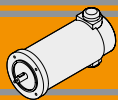
**EC350...BRL
EC600...BRL**

	P_n [W]	V [V]	M_n [Nm]	n₁ [min ⁻¹]
Caratteristiche del freno / Break features	25	12 24	5	3000



Encoder

Encoder

EC020.24E ME22

EC050.12E ME22

EC050.24E ME22

EC070.12E ME22

EC070.24E ME22

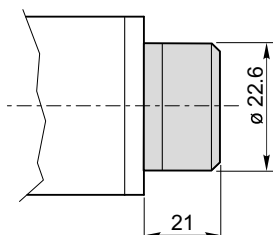

EC100.24E ME22

EC180.24E ME22

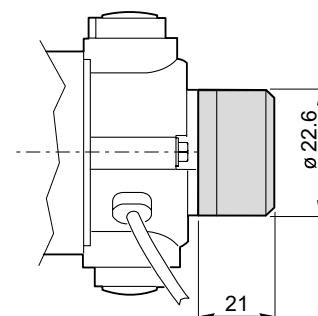

Risoluzione Encoder (CPR) / Encoder Resolution (CPR)	Numero di canali / Number of channels	Tensione d'alimentazione / Power supply
001	2	5 VdC - TTL
100		
300		

Per risoluzioni encoder non standard, si prega di contattare il nostro Servizio Tecnico.

For non-standard encoder resolution, please contact our Technical Department.

Nota: Fornito con cavo lungo 300 mm

Note: Supplie with cavle 300 mm long

MINI 
TECNO
small but strong

EC IP66



Motori elettrici CC IP66 - Ferrite
IP66 DC electric motors - Ferrite



MINI 
TECNO brand of
TRANSTECNO



DC

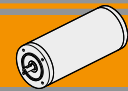

	Indice	Index	Pag. Page
EC070.120.66 EC070.240.66	Caratteristiche	<i>Features</i>	BC2
	Dimensioni	<i>Dimensions</i>	BC2
	Prestazioni	<i>Performances</i>	BC3
EC100.120.66 EC100.240.66	Caratteristiche	<i>Features</i>	BC4
	Dimensioni	<i>Dimensions</i>	BC4
	Prestazioni	<i>Performances</i>	BC4
EC180.120.66 EC180.240.66	Caratteristiche	<i>Features</i>	BC6
	Dimensioni	<i>Dimensions</i>	BC6
	Prestazioni	<i>Performances</i>	BC6
EC250.120.66 EC250.240.66	Caratteristiche	<i>Features</i>	BC8
	Dimensioni	<i>Dimensions</i>	BC8
	Prestazioni	<i>Performances</i>	BC9
EC350.120.66 EC350.240.66	Caratteristiche	<i>Features</i>	BC10
	Dimensioni	<i>Dimensions</i>	BC10
	Prestazioni	<i>Performances</i>	BC11
EC600.120.66 EC600.240.66	Caratteristiche	<i>Features</i>	BC12
	Dimensioni	<i>Dimensions</i>	BC12
	Prestazioni	<i>Performances</i>	BC13

Questa sezione annulla e sostituisce ogni precedente edizione o revisione. Qualora questa sezione non Vi sia giunta in distribuzione controllata, l'aggiornamento dei dati ivi contenuto non è assicurato. **In tal caso la versione più aggiornata è disponibile sul nostro sito internet www.transtecno.com**

*This section replaces any previous edition and revision. If you obtained this catalogue other than through controlled distribution channels, the most up to date content is not guaranteed. **In this case the latest version is available on our web site www.transtecno.com***

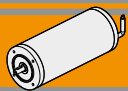

EC070.120.66 - EC070.240.66

Caratteristiche

Features

Costruzione	Tubolare, senza ventilazione
Grandezza	Ø 65 mm
Potenza	100 W S2 (70 W S1)
Magneti	2
Supporti	Cuscinetti a sfera
Fori di montaggio	4
Alimentazione	Bassa tensione, 12 o 24 Vcc
Spazzole	N° 2 interne di composto grafite-rame
Cavo di alimentazione	Lunghezza: 1000 mm

Construction	Tubular, without fan
Size	Ø 65 mm
Power	100 W S2 (70 W S1)
Magnets	2
Bearings	Ball bearings
Mounting holes	4
Power supply	Low voltage, 12 or 24 Vdc
Brushes	2 inside brushes made of graphite/copper composite
Electric cable	Length: 1000 mm

Tipo Type	S	Pn [W]	V [V]	I [A]	IC	FF	Mn [Nm]	n ₁ [min ⁻¹]	IP	Kg
EC070.120.66	S1	70	12	8.4	F	1	0.22	3000	66	1.7
	S2 30'	100		11.8			0.31			
EC070.240.66	S1	70	24	4.2			0.22			
	S2 30'	100		5.9			0.31			

Dimensioni

Dimensions

EC070.120.66
EC070.240.66

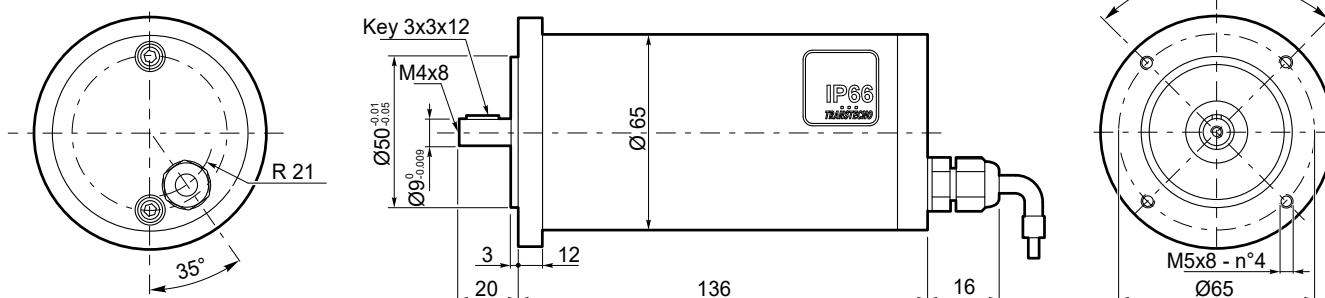



EC070.120.66 - EC070.240.66

Prestazioni

Performances

EC070.120.66

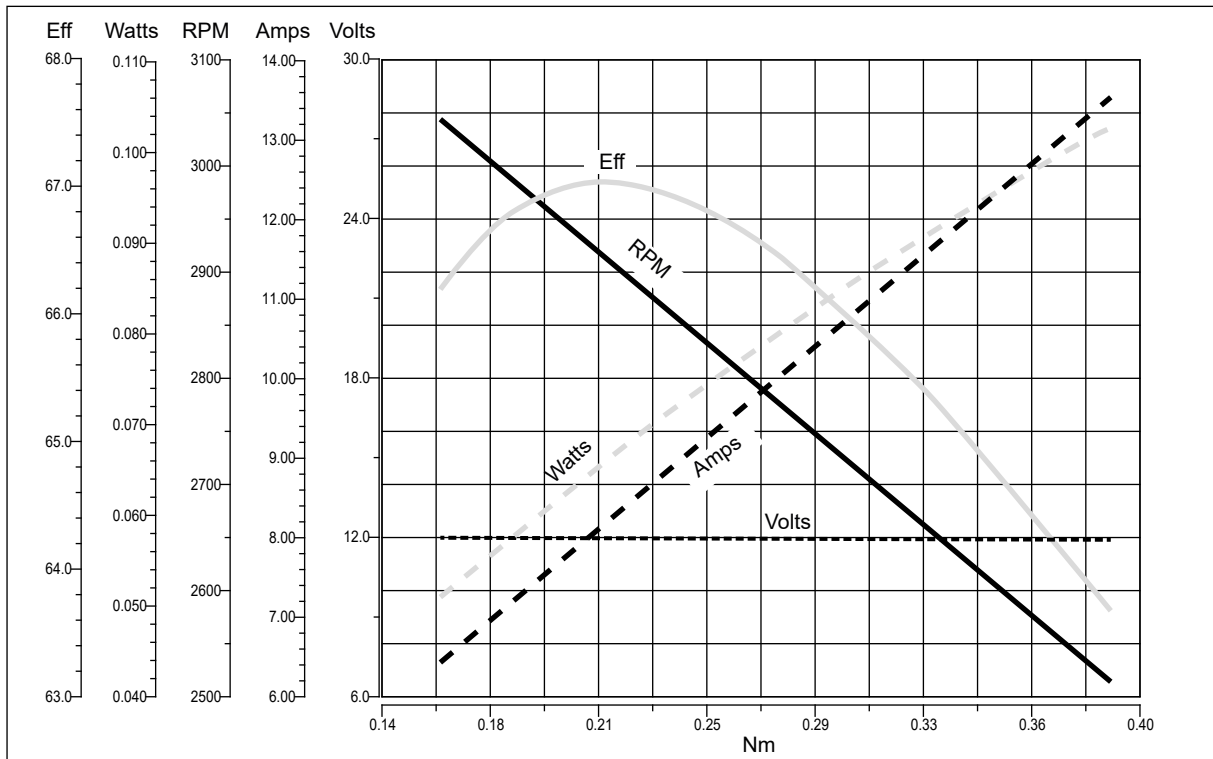

EC070.240.66

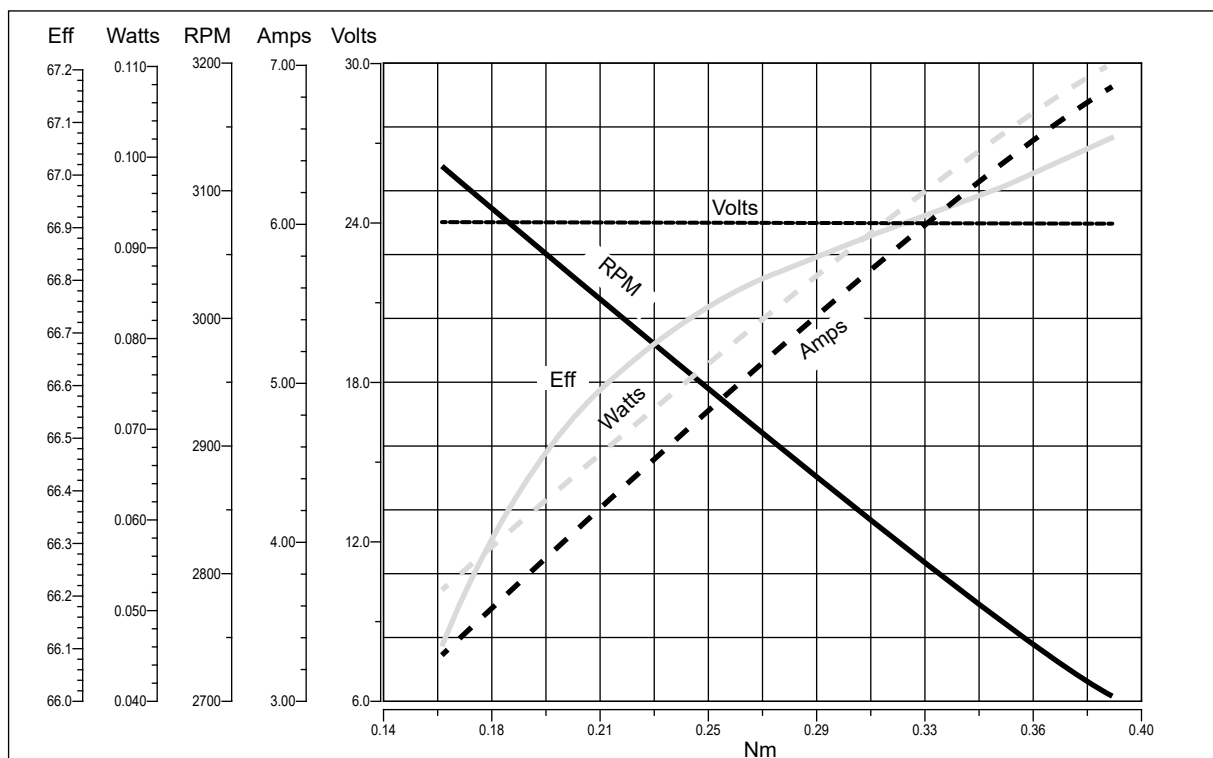

DC

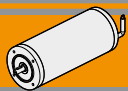

EC100.120.66 - EC100.240.66

Caratteristiche

Features

Costruzione	Tubolare, senza ventilazione
Grandezza	Ø 80 mm
Potenza	140 W S2 (100 W S1)
Magneti	2
Supporti	Cuscinetti a sfera
Fori di montaggio	4
Alimentazione	Bassa tensione, 12 o 24 Vcc
Cavo di alimentazione	Lunghezza: 1000 mm

Construction	Tubular, without fan
Size	Ø 80 mm
Power	140 W S2 (100 W S1)
Magnets	2
Bearings	Ball bearings
Mounting holes	4
Power supply	Low voltage, 12 or 24 Vdc
Electric cable	Length: 1000 mm

Tipo Type	S	Pn [W]	V [V]	I [A]	IC	FF	Mn [Nm]	n ₁ [min ⁻¹]	IP	Kg
EC100.120.66	S1	100	12	12	F	1	0.31	3000	66	2.7
	S2 25'	140		16.8			0.43			
EC100.240.66	S1	100	24	6						
	S2 25'	140		8.4			0.43			

Dimensioni

Dimensions

EC100.120.66
EC100.240.66

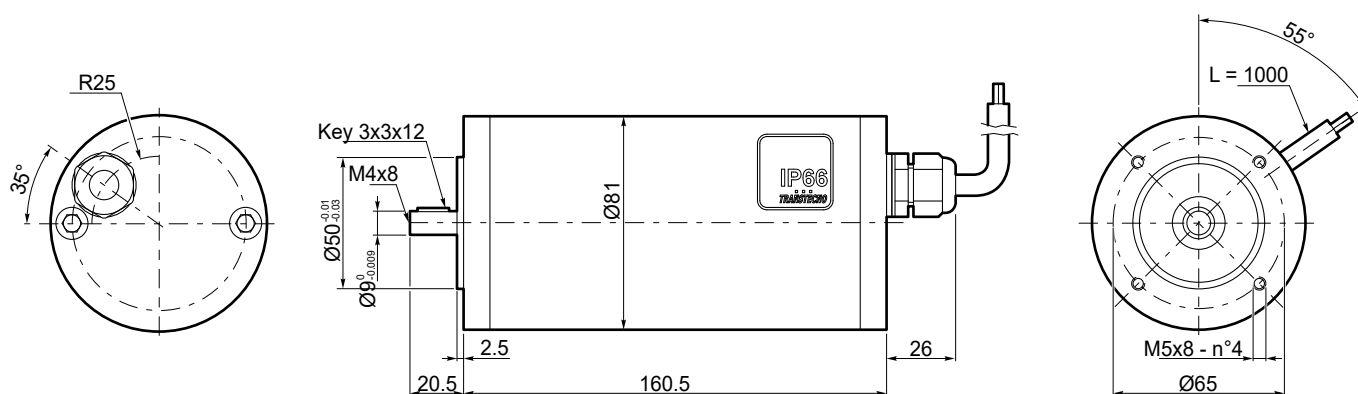

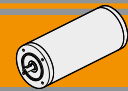

EC100.120.66

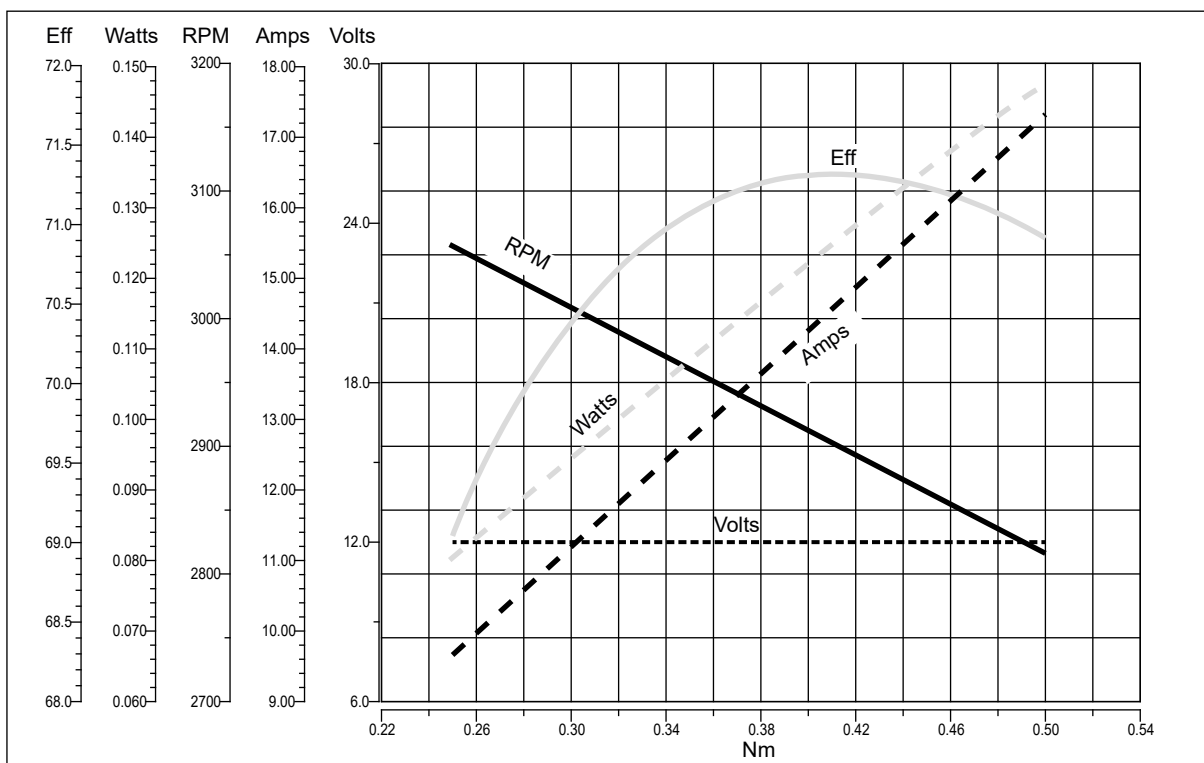

EC100.240.66

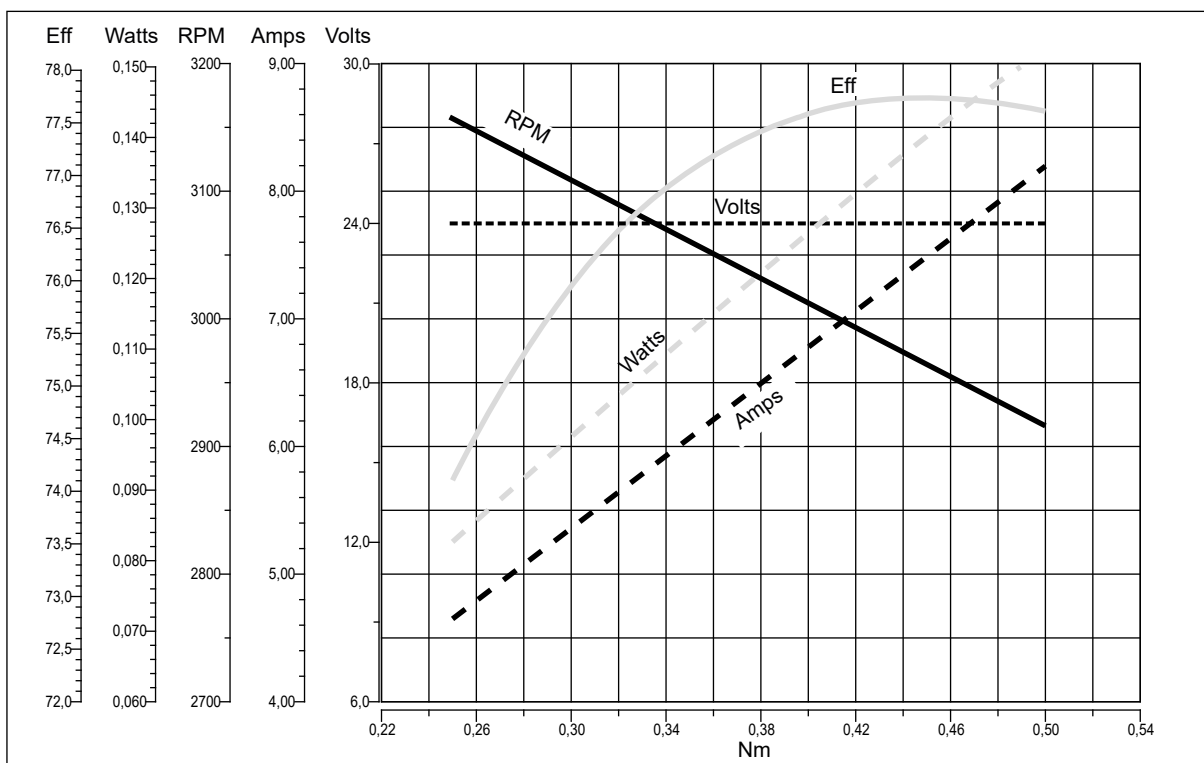

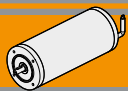

EC180.120.66 - EC180.240.66

Caratteristiche

Features

Costruzione	Tubolare, senza ventilazione
Grandezza	Ø 80 mm
Potenza	250 W S2 (180 W S1)
Magneti	2
Supporti	Cuscinetti a sfera
Fori di montaggio	4
Alimentazione	Bassa tensione, 12 o 24 Vcc
Cavo di alimentazione	Lunghezza: 1000 mm

Construction	Tubular, without fan
Size	Ø 80 mm
Power	250 W S2 (180 W S1)
Magnets	2
Bearings	Ball bearings
Mounting holes	4
Power supply	Low voltage, 12 or 24 Vdc
Electric cable	Length: 1000 mm

Tipo Type	S	Pn [W]	V [V]	I [A]	IC	FF	Mn [Nm]	n ₁ [min ⁻¹]	IP	Kg
EC180.120.66	S1	180	12	21.5	F	1	0.57	3000	66	3.4
	S2 25'	250		30			0.8			
EC180.240.66	S1	180	24	10.8						
	S2 25'	250		15			0.8			

Dimensioni

Dimensions

EC180.120.66

EC180.240.66

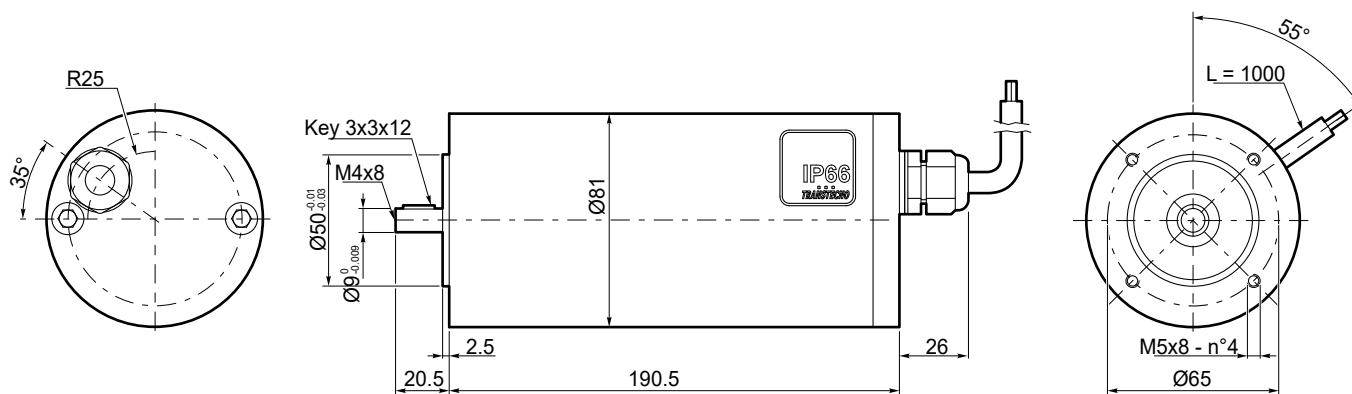

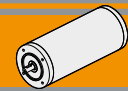

EC180.120.66

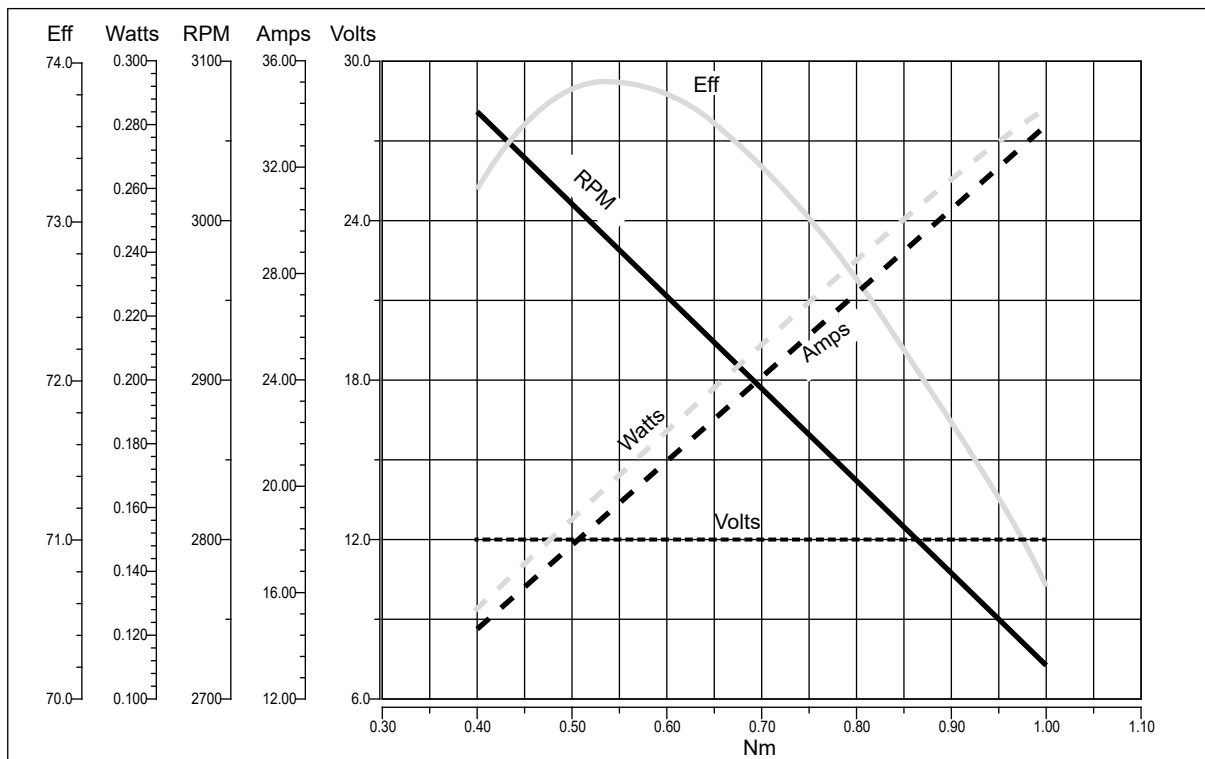

EC180.240.66

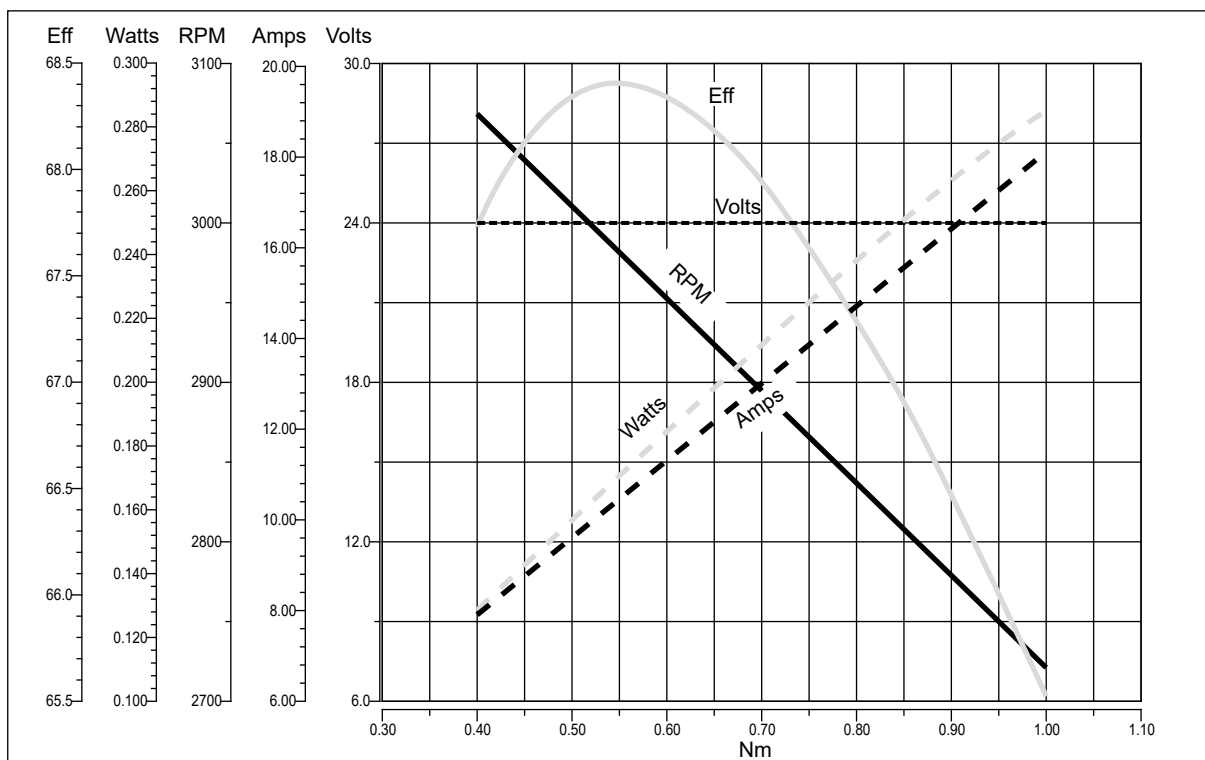

DC

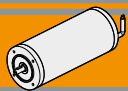

EC250.120.66 - EC250.240.66

Caratteristiche

Features

Costruzione	Tubolare, senza ventilazione
Grandezza	Ø 104 mm
Potenza	350 W S2 (250 W S1)
Magneti	4
Supporti	Cuscinetti a sfera
Fori di montaggio	8
Alimentazione	Bassa tensione, 12 o 24 Vcc
Terminali	2 con doppio dado di fissaggio

Construction	Tubular, without fan
Size	Ø 104 mm
Power	350 W S2 (250 W S1)
Magnets	4
Bearings	Ball bearings
Mounting holes	8
Power supply	Low voltage, 12 or 24 Vdc
Leads terminals	2, with double nut

Tipo Type	S	Pn [W]	V [V]	I [A]	IC	FF	Mn [Nm]	n ₁ [min ⁻¹]	IP	Kg
EC250.120.66	S1	250	12	30	F	1	0.8	3000	66	4.15
	S2 25'	350		38.5			1.12			
EC250.240.66	S1	250	24	15			0.8			
	S2 25'	350		20.5			1.12			

Dimensioni

Dimensions

EC250.120.66

EC250.240.66

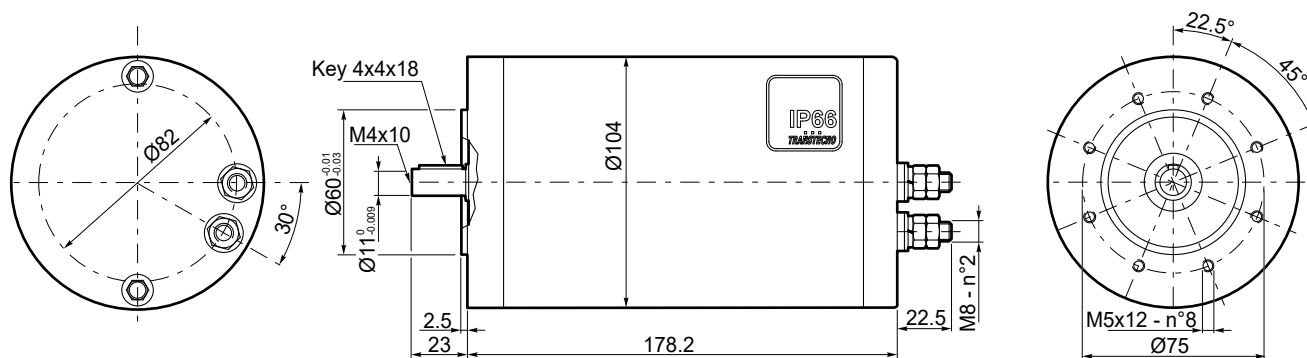

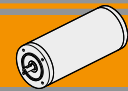

EC250.120.66

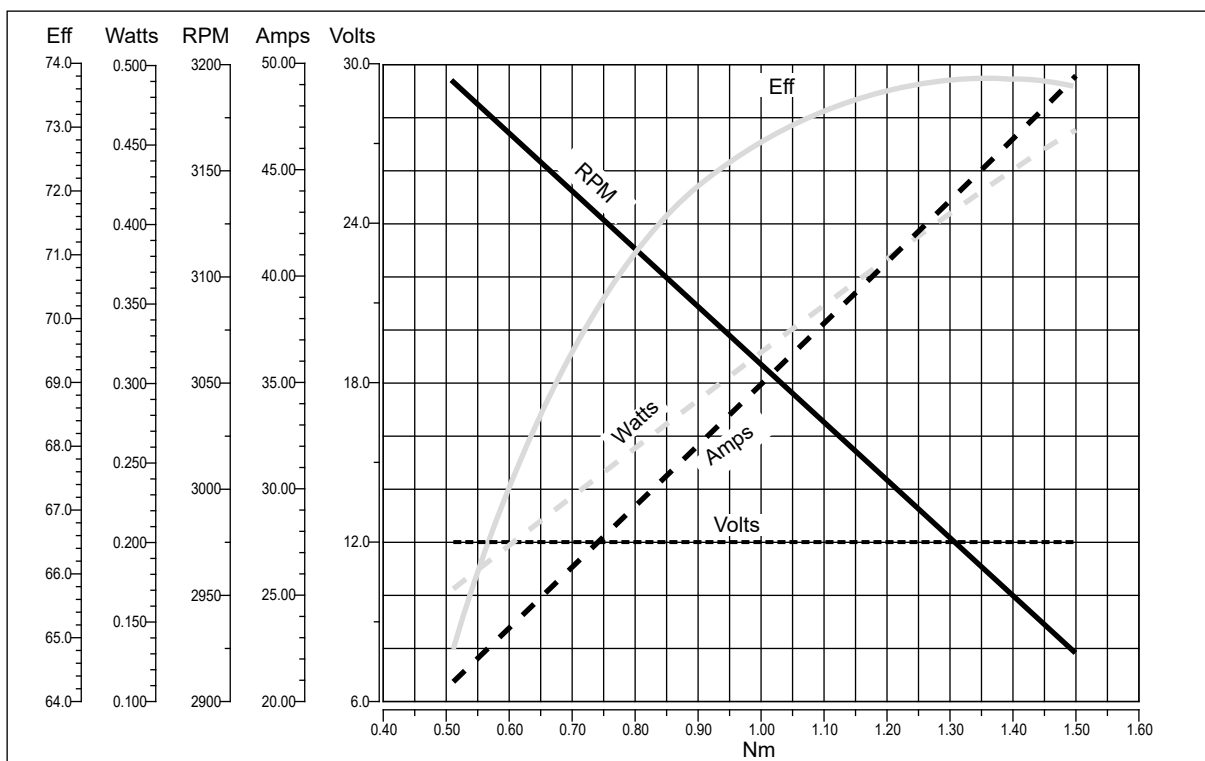

EC250.240.66

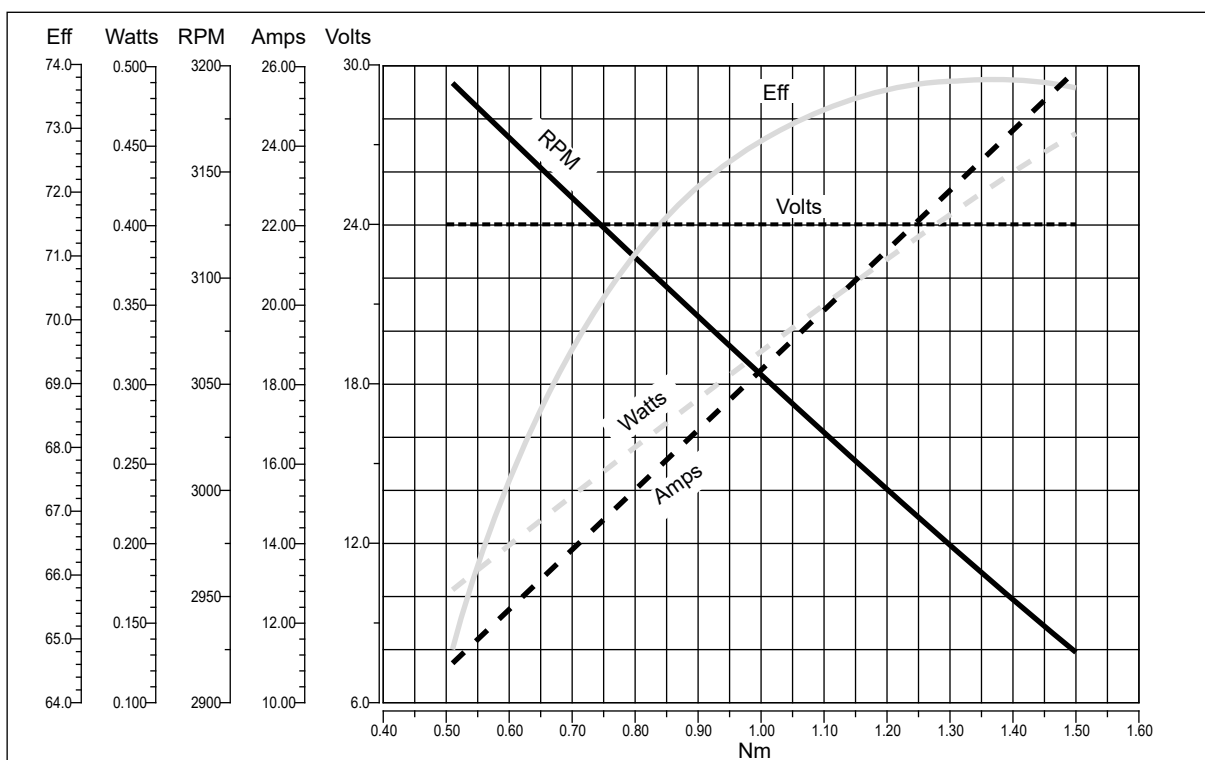

DC

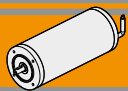

EC350.120.66 - EC350.240.66

Caratteristiche

Features

Costruzione	Tubolare, senza ventilazione
Grandezza	Ø 110 mm
Potenza	500 W S2 (350 W S1)
Magneti	4
Supporti	Cuscinetti a sfera
Fori di montaggio	8
Alimentazione	Bassa tensione, 12 o 24 Vcc
Terminali	2 con dadi di fissaggio

Construction	Tubular, without fan
Size	Ø 110 mm
Power	500 W S2 (350 W S1)
Magnets	4
Bearings	Ball bearings
Mounting holes	8
Power supply	Low voltage, 12 or 24 Vdc
Leads terminals	2, with double nut

Tipo Type	S	Pn [W]	V [V]	I [A]	IC	FF	Mn [Nm]	n ₁ [min ⁻¹]	IP	Kg
EC350.120.66	S1	350	12	42	F	1	1.12	3000	66	5.1
	S2 30'	500		58.8			1.57			
EC350.240.66	S1	350	24	21			1.12			5.3
	S2 30'	500		29.4			1.57			

Dimensioni

Dimensions

EC350.120.66
EC350.240.66

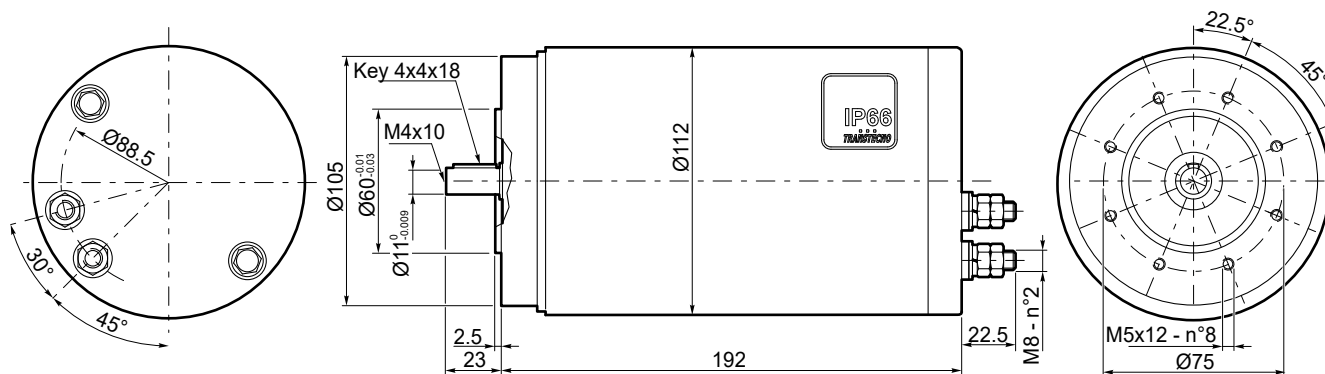



EC350.120.66

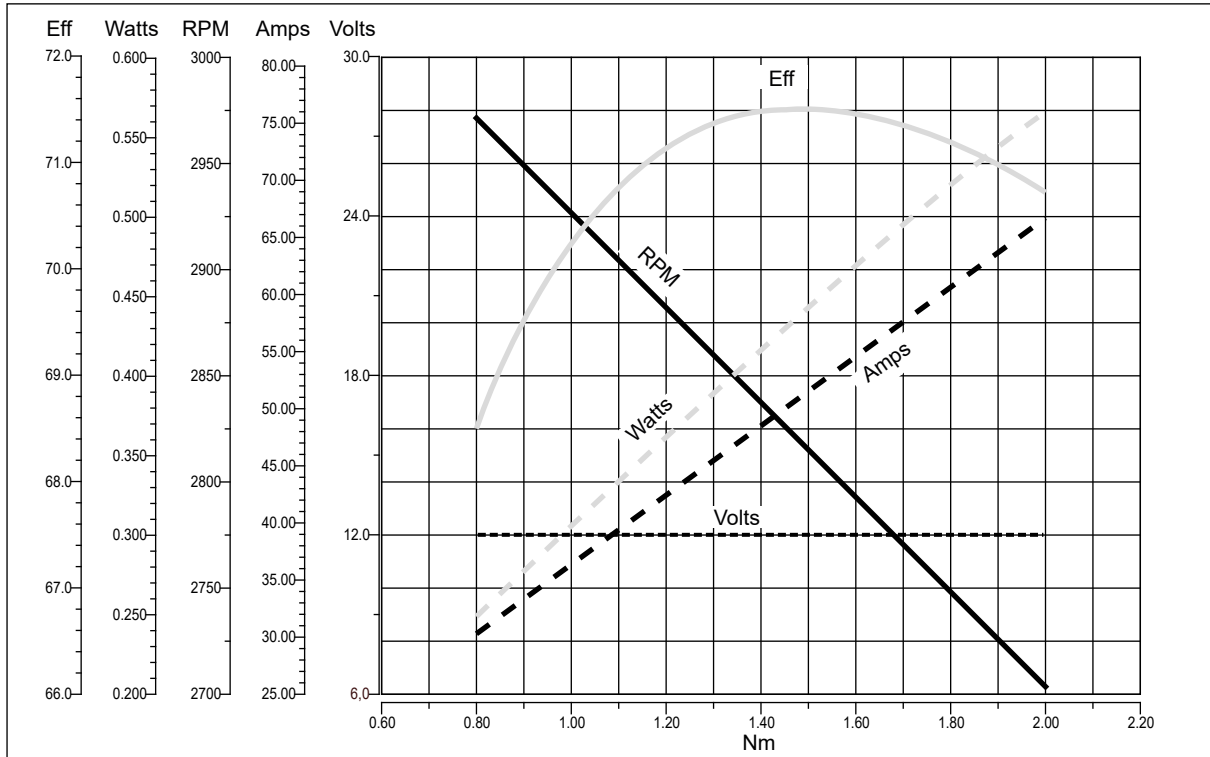

EC350.240.66

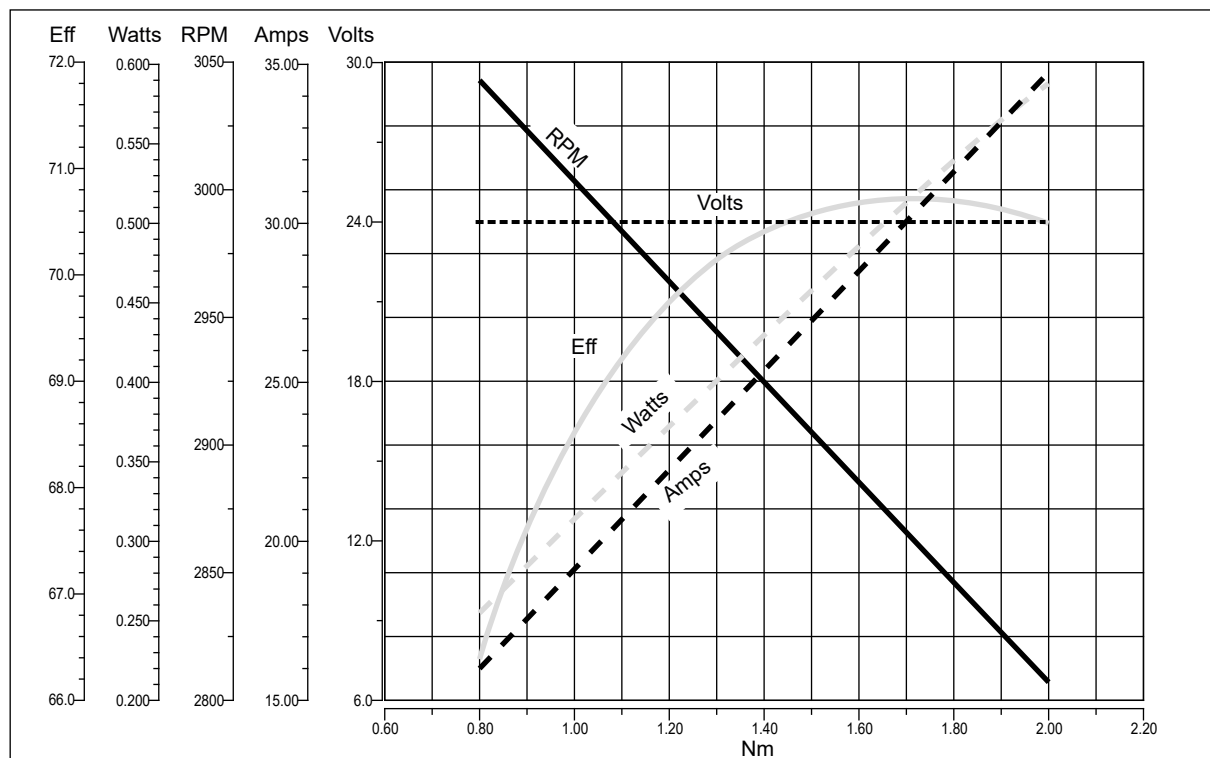

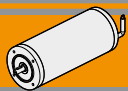

EC600.120.66 - EC600.240.66

Caratteristiche

Features

Costruzione	Tubolare, senza ventilazione
Grandezza	Ø 110 mm
Potenza	800 W S2 (600 W S1)
Magneti	4
Supporti	Cuscinetti a sfera
Fori di montaggio	8
Alimentazione	Bassa tensione, 12 o 24 Vcc
Terminali	2 con doppio dado di fissaggio

Construction	Tubular, without fan
Size	Ø 110 mm
Power	800 W S2 (600 W S1)
Magnets	4
Bearings	Ball bearings
Mounting holes	8
Power supply	Low voltage, 12 or 24 Vdc
Leads terminals	2, with double nut

Tipo Type	S	Pn [W]	V [V]	I [A]	IC	FF	Mn [Nm]	n ₁ [min ⁻¹]	IP	Kg
EC600.120.66	S1	600	12	71	F	1	1.91	3000	66	6.6
	S2 30'	800		94.4			2.54			
EC600.240.66	S1	600	24	35.5			1.91			7.1
	S2 30'	800		47.2			2.54			

Dimensioni

Dimensions

EC600.120.66

EC600.240.66

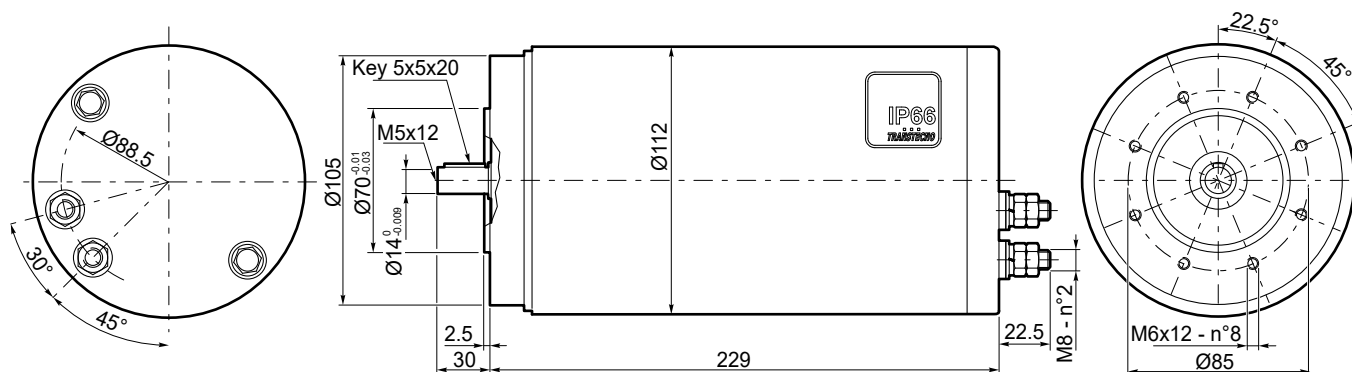



EC600.120.66

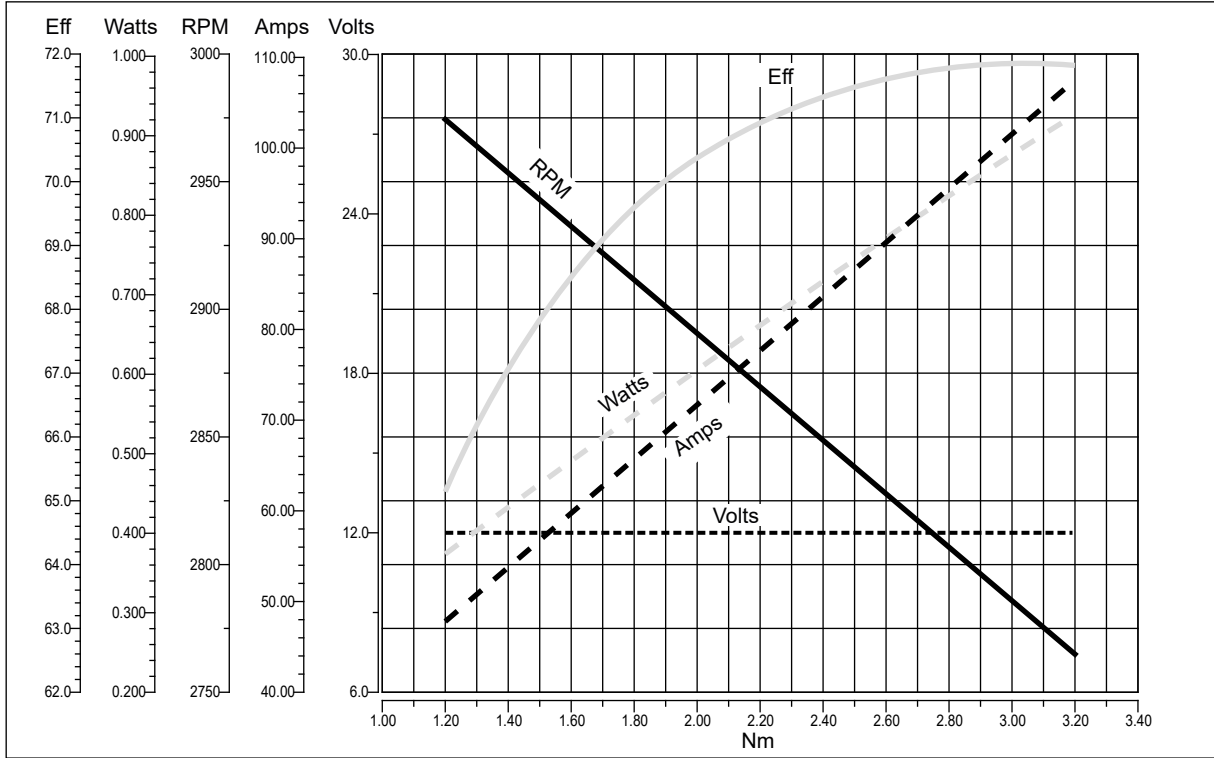

EC600.240.66

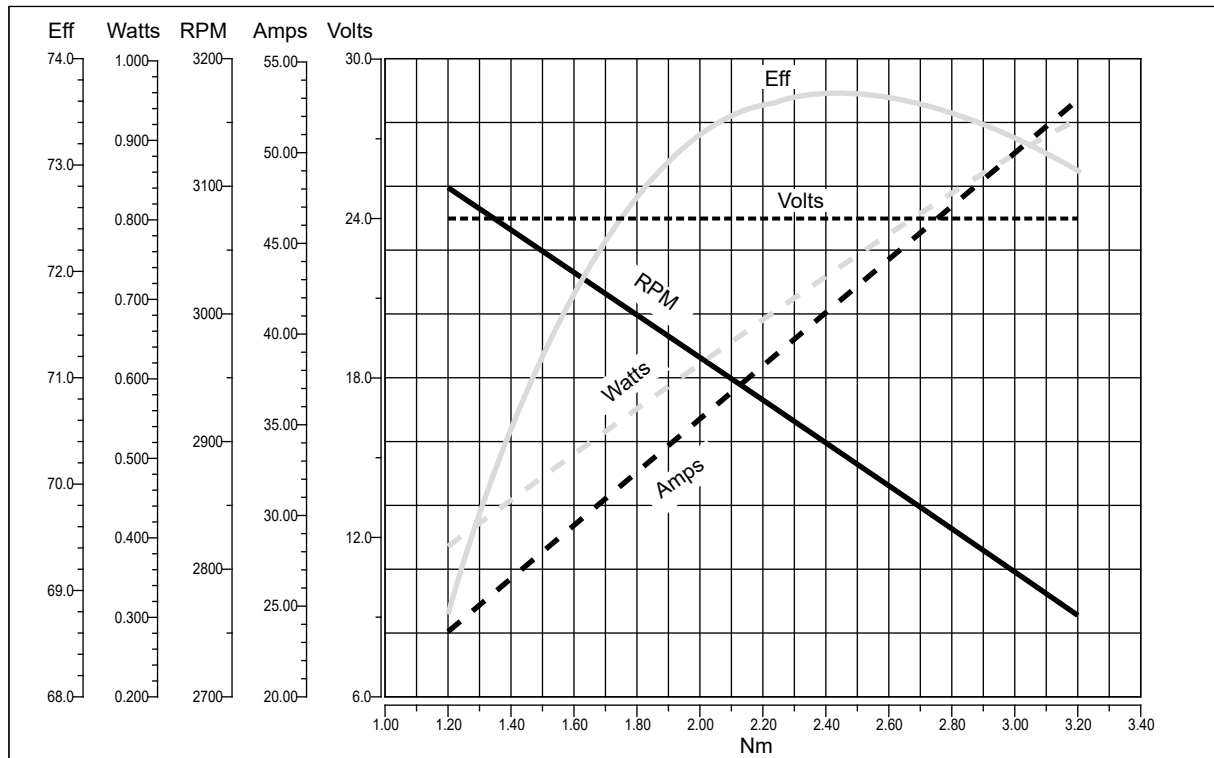

DC

Motoriduttori CC ad ingranaggi cilindrici
DC helical in-line gearmotors



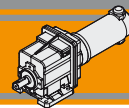

Indice	Index	Pag. Page
Caratteristiche tecniche	<i>Technical features</i>	BD2
Designazione	<i>Classification</i>	BD3
Sensi di rotazione	<i>Direction of rotation</i>	BD3
Lubrificazione	<i>Lubrication</i>	BD3
Simbologia	<i>Symbols</i>	BD3
Carichi radiali	<i>Radial loads</i>	BD4
Motori applicabili	<i>IEC Motor adapters</i>	BD4
Dati tecnici per servizio S2	<i>Technical data for S2 duty</i>	BD5
Dimensioni	<i>Dimensions</i>	BD7

Questa sezione annulla e sostituisce ogni precedente edizione o revisione. Qualora questa sezione non Vi sia giunta in distribuzione controllata, l'aggiornamento dei dati ivi contenuto non è assicurato. **In tal caso la versione più aggiornata è disponibile sul nostro sito internet www.transtecno.com**

This section replaces any previous edition and revision. If you obtained this catalogue other than through controlled distribution channels, the most up to date content is not guaranteed. In this case the latest version is available on our web site www.transtecno.com

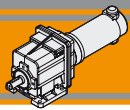

Caratteristiche tecniche

Technical features

I motoriduttori CC ad ingranaggi cilindrici a magneti permanenti in neodimio **NDCMG** e in ferrite **ECMG** hanno le seguenti caratteristiche principali:

- Alimentazione in bassa tensione 12/24 Vcc
- Possibilità di montaggio encoder e freno
- Potenze motore disponibili da 100 a 800W S2
- Carcasse dei riduttori in pressofusione di alluminio
- Lubrificazione permanente con olio sintetico
- Ingranaggi cilindrici a denti elicoidali, induriti e rettificati

NDCMG neodymium permanent magnets and **ECMG** ferrite permanent magnets DC helical in-line gearmotors range has the following main features:

- Low voltage power supply 12/24 Vdc
- Suitable for encoder and brake assembly
- Motor power ratings available from 100 to 800W S2
- Die-cast aluminum housing
- Permanent synthetic oil long-life lubrication
- Ground-hardened helical gears

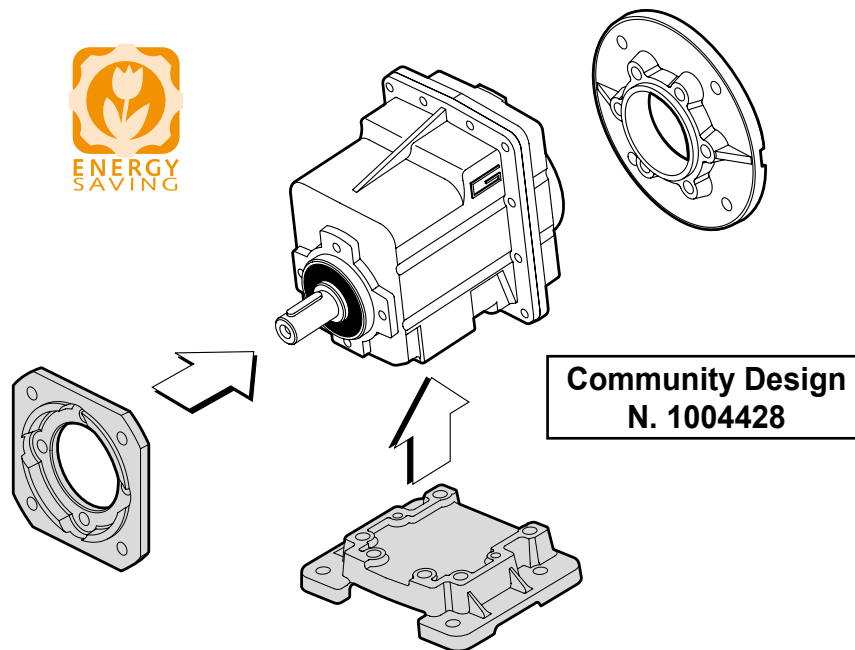

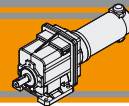

Designazione

Classification

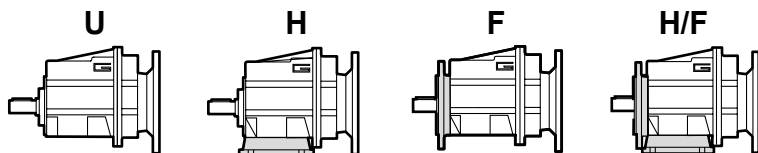

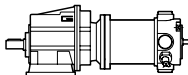
MOTORIDUTTORE / GEARMOTOR					
NDCMG	120/002	U	8.99	D20	240
Tipo Type	Grandezza Size	Versione Version	Rapporto Ratio	Albero uscita Output shaft	Versione motore Motor version
NDCMG 	120/002 180/002	U... H... F... H.../F...	vedi tabelle see tables	vedi tabelle see tables	120 240

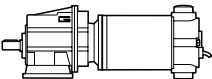
MOTORIDUTTORE / GEARMOTOR					
ECMG	100/002	U	8.99	D20	240
Tipo Type	Grandezza Size	Versione Version	Rapporto Ratio	Albero uscita Output shaft	Versione motore Motor version
ECMG 	070/002 100/002 180/002 250/002 350/002 600/002	U... H... F... H.../F...	vedi tabelle see tables	vedi tabelle see tables	120 240 24E

Sensi di rotazione

Direction of rotation

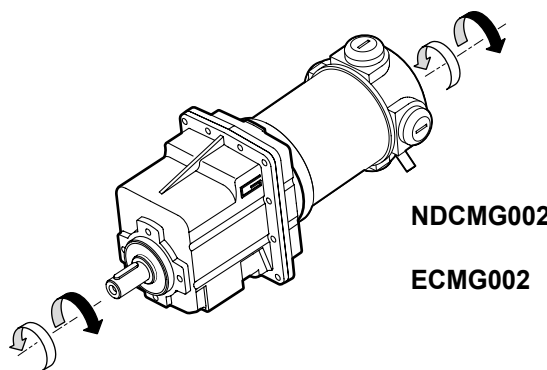

NDCMG002

ECMG002

Lubrificazione

Lubrication

Tutti i riduttori sono forniti completi di lubrificante sintetico viscosità 320, pertanto possono essere installati in qualunque posizione di montaggio e non necessitano di manutenzione.

Permanent synthetic oil long-life lubrication (viscosity grade 320) makes it possible to use in all mounting positions; for this reason they can be installed in any assembly position and do not require maintenance.

Simbologia

Symbols

n_1	[min ⁻¹]	Velocità in ingresso / <i>Input speed</i>
n_2	[min ⁻¹]	Velocità in uscita / <i>Output speed</i>
i		Rapporto di riduzione / <i>Ratio</i>
P_1	[kW]	Potenza in entrata / <i>Input power</i>
M_2	[Nm]	Coppia nominale in uscita in funzione di P_1 / <i>Output torque referred to P_1</i>
sf		Fattore di servizio / <i>Service factor</i>
R_2	[N]	Carico radiale ammissibile in uscita / <i>Permitted output radial load</i>
A_2	[N]	Carico assiale ammissibile in uscita / <i>Permitted output axial load</i>

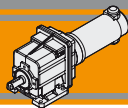

Carichi radiali

Radial loads

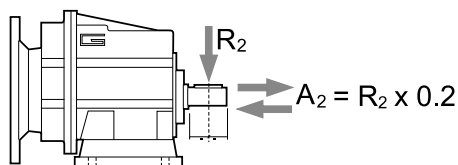

n ₂ [min ⁻¹]	R ₂ [N]
	CMG 002
700	416
600	437
500	465
400	501
250	586
180	653
150	748
120	806
100	958
80	1032
60	1136
40	1300
10	1300

Quando il carico radiale risultante non è applicato sulla mezza-
ria dell'albero occorre calcolare quello effettivo con la seguente
formula:

When the resulting radial load is not applied on the centre line
of the shaft it is necessary to calculate the effective load with the
following formula:

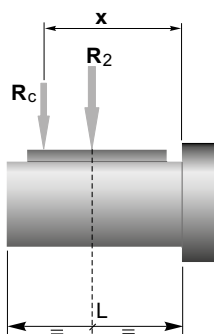

	CMG 002
a	73
b	53
R _{2MAX}	1300

$$R_c = \frac{R_2 \cdot a}{(b+x)} \leq R_{2MAX}$$

a, b = valori riportati nella tabella
a, b = values given in the table

$$R \leq R_c$$

Motori applicabili

IEC Motor adapters

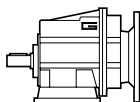
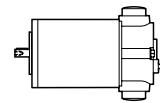
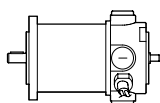

CMG	002	ND		EC						
		120.120 120.240	180.120 180.240	070.12E 070.24E	100.120 100.240 100.24E	180.120 180.240	180.24E	250.120 250.240	350.120 350.240	600.120 600.240
		5.03 - 55.10								

5.03 - 55.10

Rapporti di riduzione i
Ratio i

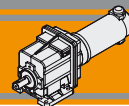

Dati tecnici per servizio S2

ND CMG

Technical data for S2 duty

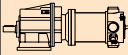
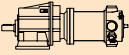
P_1 [W]	n_2 [min ⁻¹]	M_2 [Nm]	sf	i		Versione motore Motor version	P_1 [W]	n_2 [min ⁻¹]	M_2 [Nm]	sf	i		Versione motore Motor version			
160							250									
(3000 min ⁻¹)	596	2.5	12.6	5.03	120/002	120/240	(3000 min ⁻¹)	596	3.8	8.1	5.03	180/002	120/240			
	492	3.0	10.4	6.10					492	4.7	6.7			6.10		
	401	3.7	8.5	7.49					401	5.7	5.4			7.49		
	334	4.4	8.9	8.99					334	6.9	5.7			8.99		
	295	5.0	7.9	10.16					295	7.8	5.0			10.16		
	249	5.9	6.6	12.07					249	9.2	4.2			12.07		
	224	6.6	8.4	13.40					224	10	5.4			13.40		
	198	7.4	7.4	15.14					198	12	4.8			15.14		
	165	8.9	6.2	18.17					165	14	4.0			18.17		
	139	11	5.2	21.58					139	17	3.3			21.58		
	128	12	4.8	23.51					128	18	3.1			23.51		
	120	12	4.5	25.10					120	19	2.9			25.10		
	111	13	4.2	27.08					111	21	2.7			27.08		
	92	16	3.5	32.49					92	25	2.2			32.49		
	71	21	2.7	42.04					71	32	1.7			42.04		
	67	22	2.5	44.89					67	34	1.6			44.89		
	61	24	2.3	48.86			61	37	1.5	48.86						
	54	27	2.0	55.10			54	42	1.3	55.10						

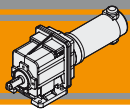

Dati tecnici per servizio S2

EC CMG

Technical data for S2 duty

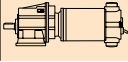
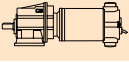
P_1 [W]	n_2 [min ⁻¹]	M_2 [Nm]	sf	i		Versione motore Motor version	P_1 [W]	n_2 [min ⁻¹]	M_2 [Nm]	sf	i		Versione motore Motor version			
100																
(3000 min ⁻¹)	596	1.5	20.2	5.03	070/002	12E/24E	(3000 min ⁻¹)	596	5.4	5.8	5.03	250/002	120/240			
	492	1.9	16.6	6.10					492	6.5	4.8			6.10		
	401	2.3	13.5	7.49					401	8.0	3.9			7.49		
	334	2.7	14.2	8.99					334	10	4.1			8.99		
	295	3.1	12.6	10.16					295	11	3.6			10.16		
	249	3.7	10.6	12.07					249	13	3.0			12.07		
	224	4.1	13.4	13.40					224	14	3.8			13.40		
	198	4.6	11.9	15.14					198	16	3.4			15.14		
	165	5.5	9.9	18.17					165	19	2.8			18.17		
	139	6.6	8.3	21.58					139	23	2.4			21.58		
	128	7.2	7.7	23.51					128	25	2.2			23.51		
	120	7.7	7.2	25.10					120	27	2.0			25.10		
	111	8.3	6.6	27.08					111	29	1.9			27.08		
	92	9.9	5.5	32.49					92	35	1.6			32.49		
	71	13	4.3	42.04					71	45	1.2			42.04		
	67	14	4.0	44.89					67	48	1.1			44.89		
	61	15	3.7	48.86			61	52	1.1	48.86						
	54	17	3.3	55.10			54	59	0.9	55.10						
140																
(3000 min ⁻¹)	596	2.2	14.4	5.03	100/002	120/240/24E	(3000 min ⁻¹)	596	7.7	4.0	5.03	350/002	120/240			
	492	2.6	11.9	6.10					492	9.3	3.3			6.10		
	401	3.2	9.7	7.49					401	11	2.7			7.49		
	334	3.8	10.1	8.99					334	14	2.8			8.99		
	295	4.3	9.0	10.16					295	16	2.5			10.16		
	249	5.2	7.6	12.07					249	18	2.1			12.07		
	224	5.7	9.6	13.40					224	20	2.7			13.40		
	198	6.5	8.5	15.14					198	23	2.4			15.14		
	165	7.8	7.1	18.17					165	28	2.0			18.17		
	139	9.2	6.0	21.58					139	33	1.7			21.58		
	128	10	5.5	23.51					128	36	1.5			23.51		
	120	11	5.1	25.10					120	38	1.4			25.1		
	111	12	4.7	27.08					111	41	1.3			27.08		
	92	14	4.0	32.49					92	50	1.1			32.49		
	71	18	3.1	42.04					71	64	0.9			42.04		
	67	19	2.9	44.89					67	69	0.8			44.89		
	61	21	2.6	48.86			61	75	0.7	48.86						
	54	24	2.3	55.10												
250																
(3000 min ⁻¹)	596	3.8	8.1	5.03	180/002	120/240/24E	(3000 min ⁻¹)	596	12	2.5	5.03	600/002	120/240			
	492	4.7	6.7	6.10					492	15	2.1			6.10		
	401	5.7	5.4	7.49					401	18	1.7			7.49		
	334	6.9	5.7	8.99					334	22	1.8			8.99		
	295	7.8	5.0	10.16					295	25	1.6			10.16		
	249	9.2	4.2	12.07					249	30	1.3			12.07		
	224	10	5.4	13.40					224	33	1.7			13.40		
	198	12	4.8	15.14					198	37	1.5			15.14		
	165	14	4.0	18.17					165	44	1.2			18.17		
	139	17	3.3	21.58					139	53	1.0			21.58		
	128	18	3.1	23.51					128	57	1.0			23.51		
	120	19	2.9	25.10					120	61	0.9			25.10		
	111	21	2.7	27.08					111	66	0.8			27.08		
	92	25	2.2	32.49					92	79	0.7			32.49		
	71	32	1.7	42.04					71	79	0.7			42.04		
	67	34	1.6	44.89					67	79	0.7			44.89		
	61	37	1.5	48.86												
	54	42	1.3	55.10												

NOTA
Verificare sempre che la coppia M2 utilizzata non ecceda il valore indicato nelle caselle in grigio

NOTE
Please check that the output torque M2 does not exceed the value in the grey areas

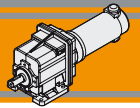

Dimensioni

Dimensions

NDCMG..U

NDCMG120/002 U
NDCMG180/002 U

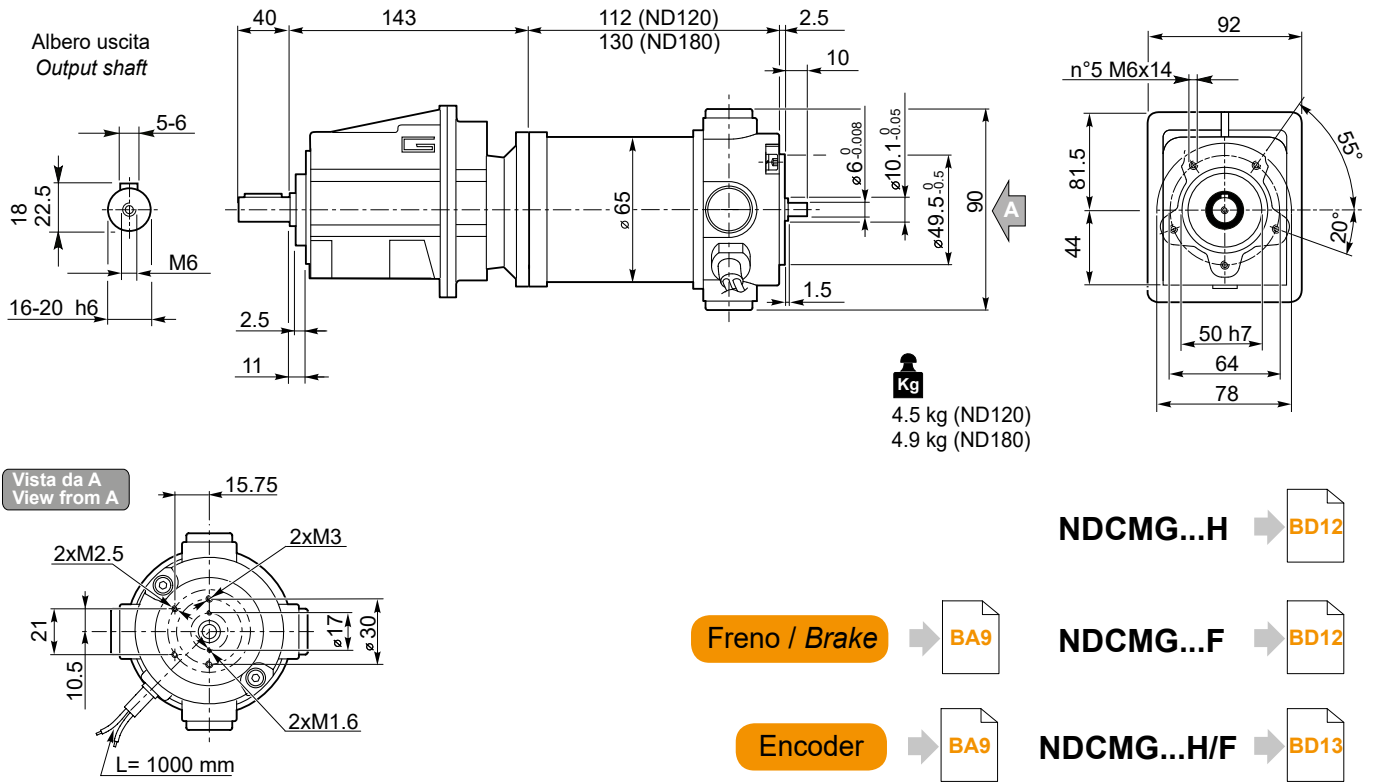

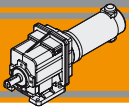

Dimensioni

Dimensions

ECMG..U

ECMG070/002 U

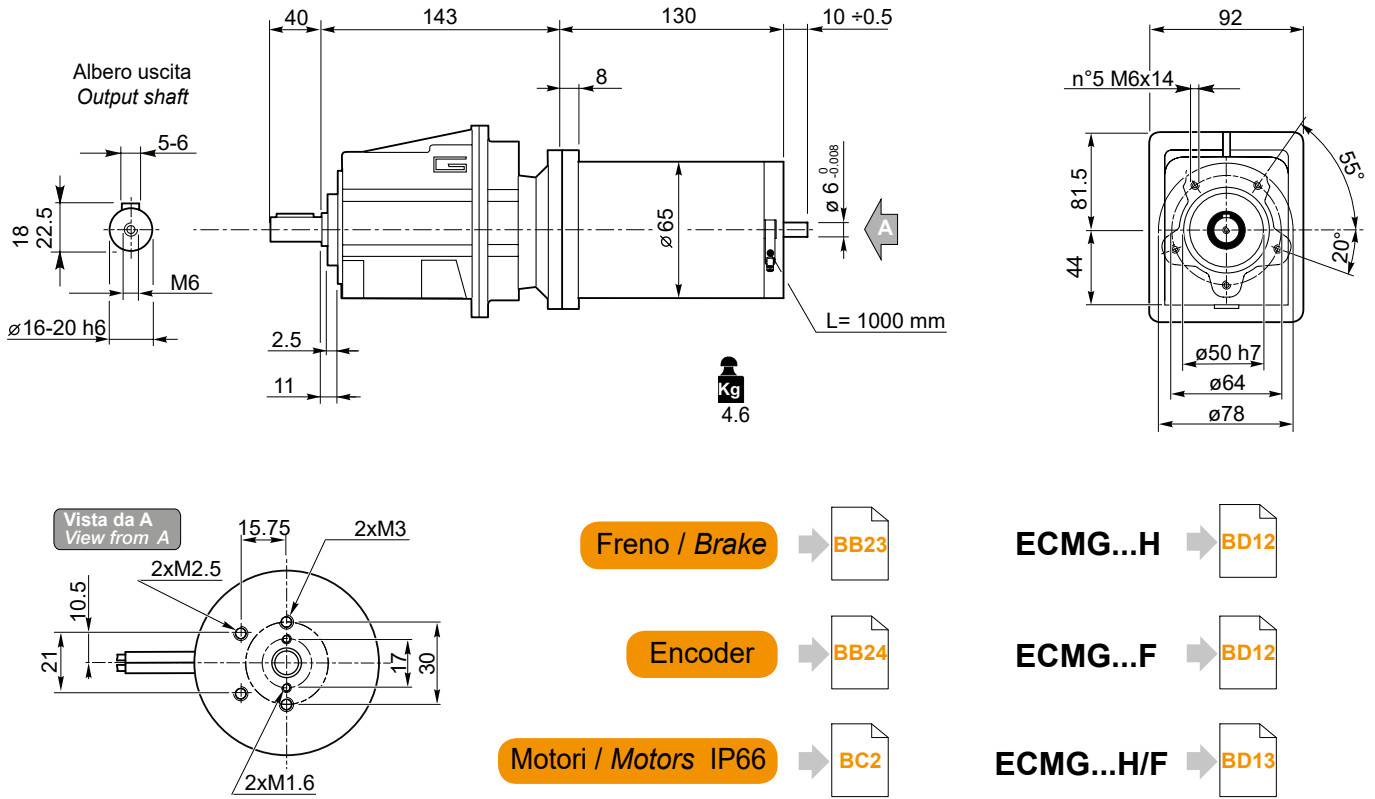

Dimensioni

Dimensions

ECMG..U

ECMG100/002 U

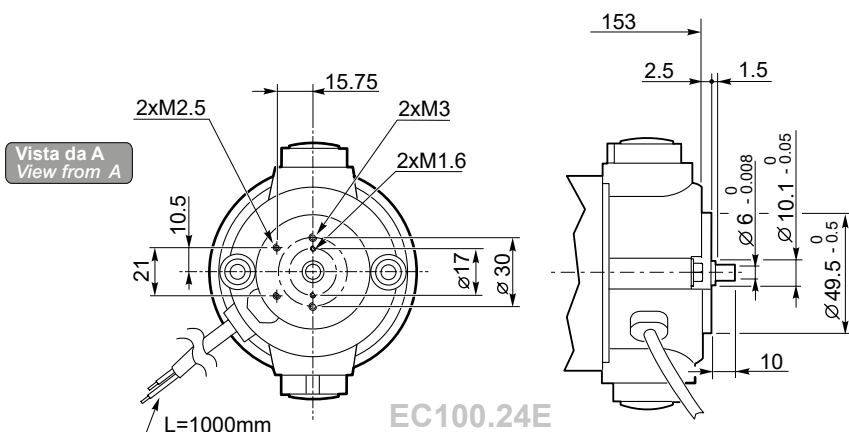
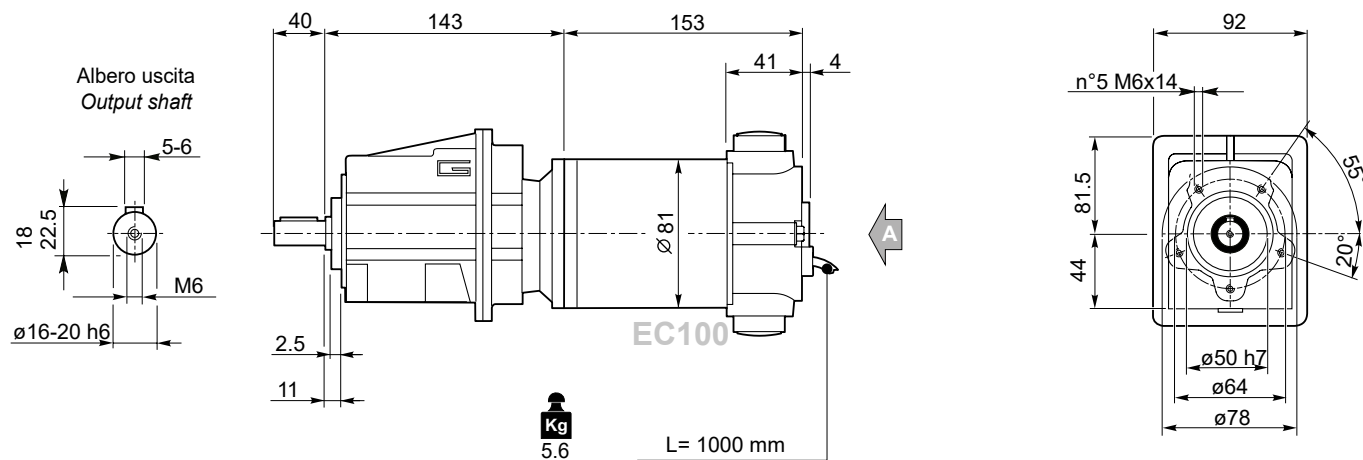

- Freno / Brake** → BB23
- Encoder** → BB24
- Motori / Motors IP66** → BC4
- ECMG...H** → BD12
- ECMG...F** → BD12
- ECMG...H/F** → BD13

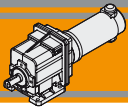

Dimensioni

Dimensions

ECMG..U

ECMG180/002 U

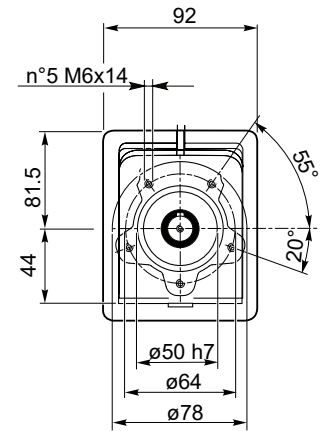
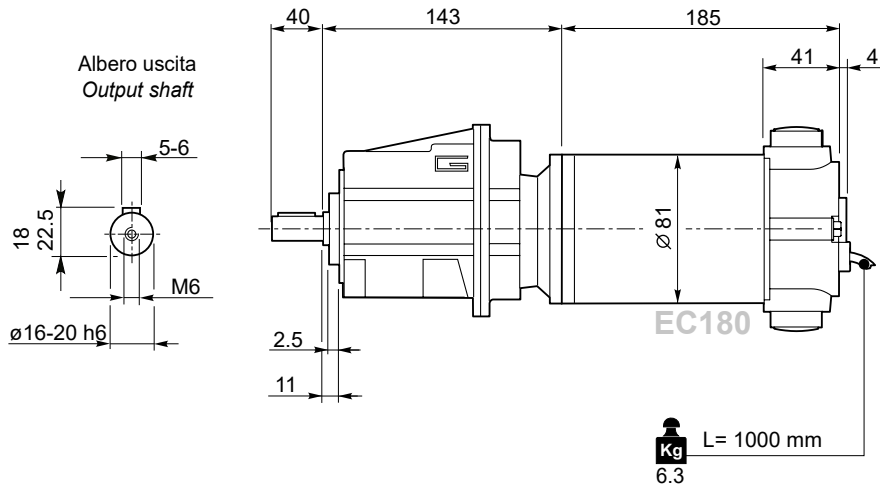

Vista da A
View from A

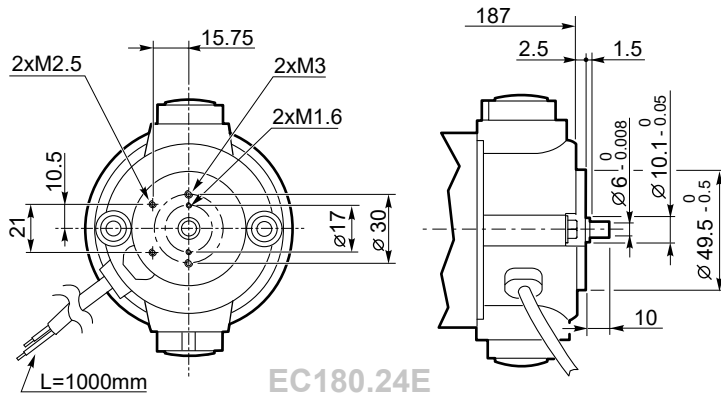

Freno / Brake → [BB23](#)

Encoder → [BB24](#)

Motori / Motors IP66 → [BC6](#)

ECMG...H → [BD12](#)

ECMG...F → [BD12](#)

ECMG...H/F → [BD13](#)

ECMG250/002 U

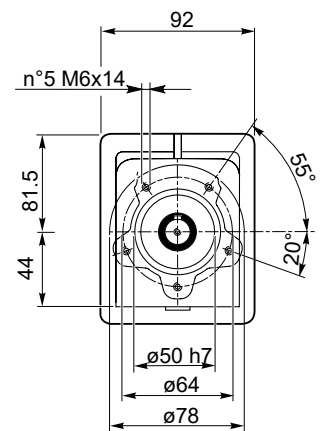
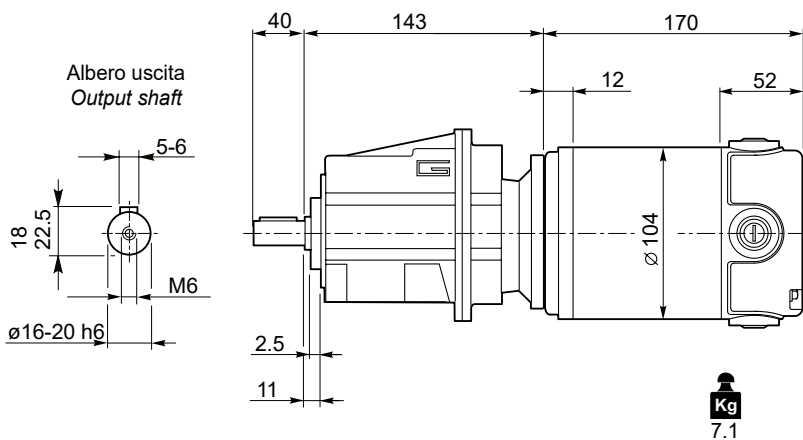

Motori / Motors IP66 → [BC8](#)

ECMG...H → [BD12](#)

ECMG...F → [BD12](#)

ECMG...H/F → [BD13](#)

Dimensioni

Dimensions

ECMG..U

ECMG350/002 U

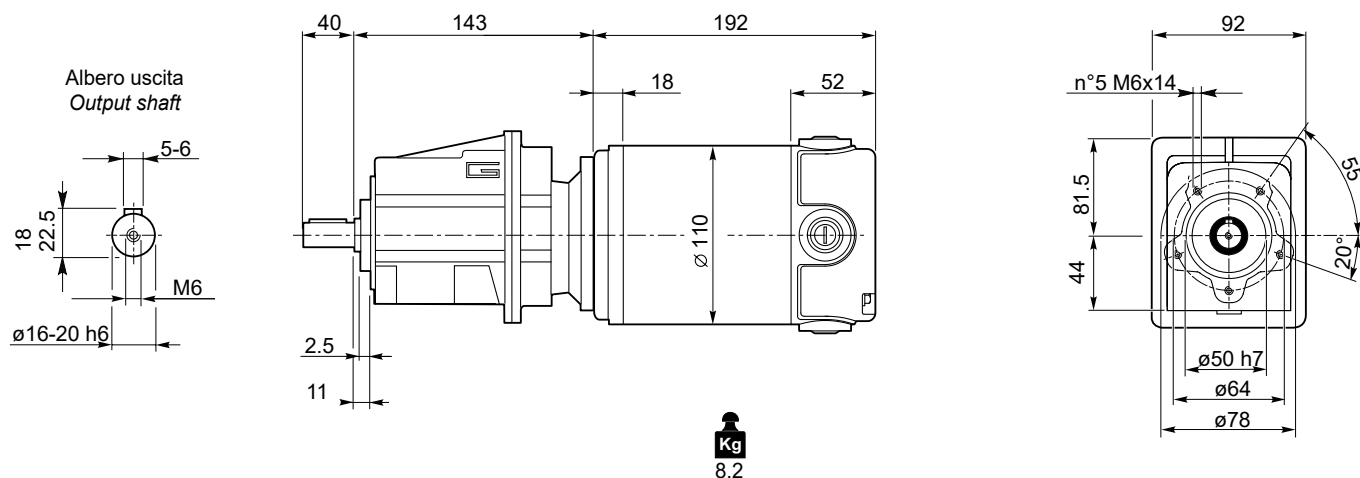

Freno / Brake



Motori / Motors IP66



ECMG...H



ECMG...F



ECMG...H/F



ECMG600/002 U

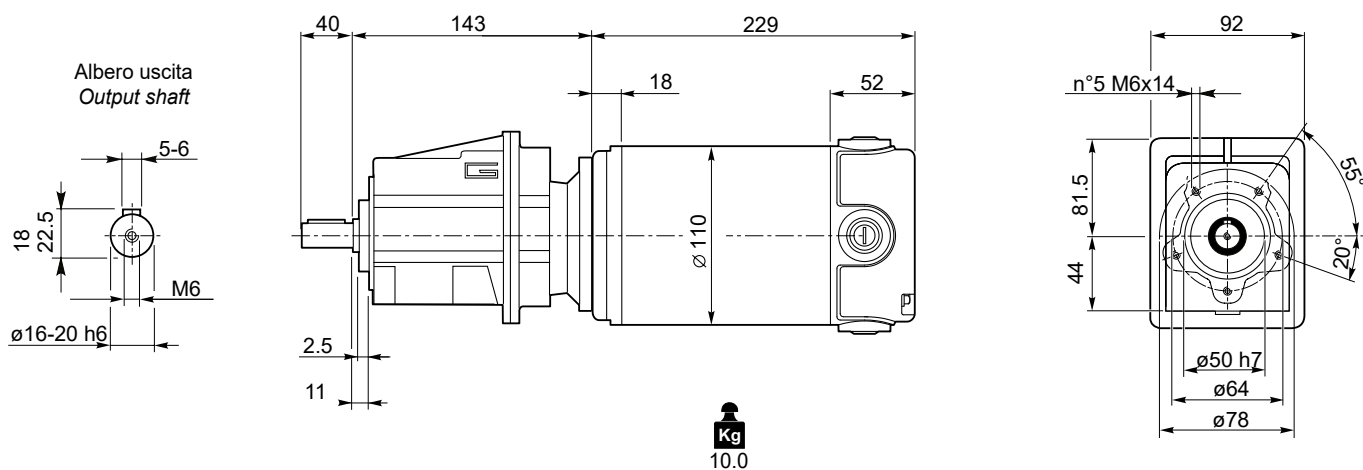

Freno / Brake



Motori / Motors IP66



ECMG...H



ECMG...F



ECMG...H/F



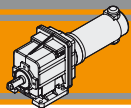

Dimensioni

Dimensions

NDCMG..H - ECMG..H

**NDCMG..2 H..
ECMG..2 H..**

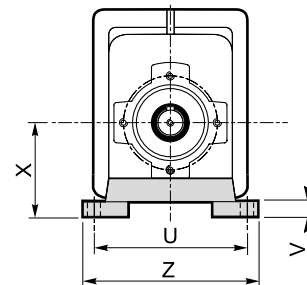
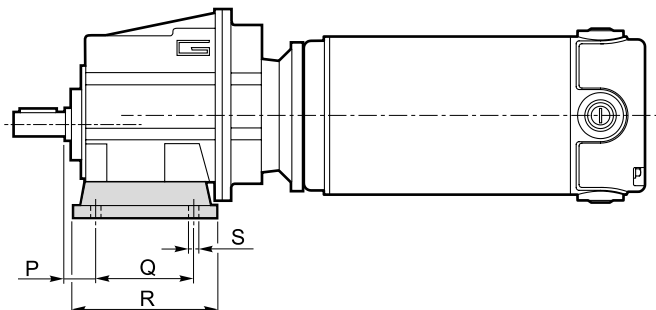

Versione H / H Version										
CMG	P	Q	R	S	U	V	X	Z	Piede / Foot	
									Tipo / Type	Peso / Weight [kg]
002	18	60	80	9	100	10	60	120	H60	0.2
	18	80	104	9	110 - 120	10	75	145	H75	0.3
	18	50 - 87	110	9	110	10	85	135	H85	0.4

■ Preferenziale / Preferred

NDCMG..F - ECMG..F

**NDCMG..2 F..
ECMG..2 F..**

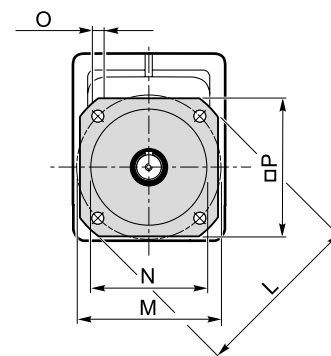
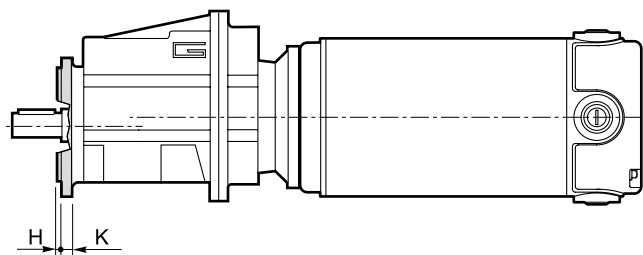

Versione F / F Version										
CMG	H	K	L	M	N f7	O	P	Flangia / Flange		
								Tipo / Type	Peso / Weight [kg]	
002	3.5	7	105	85	70	6.5	90	F105	0.1	
	3.5	8	120	100	80	7	100	F120	0.2	
	3.5	8	140	115	95	9	115	F140	0.2	

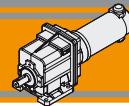

Dimensioni

Dimensions

NDCMG..H../F.. - ECMG..H../F..

NDCMG..2 H../F..
ECMG..2 H../F..

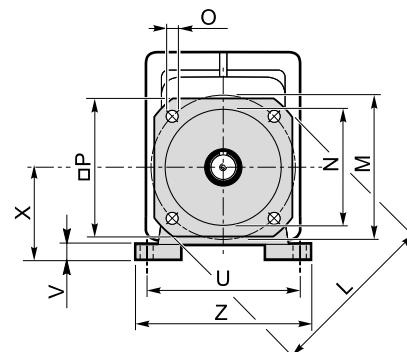
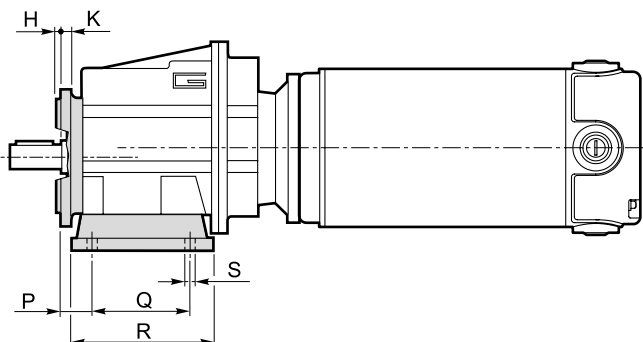

Versione H / H Version									Combinazioni possibili H/F Possible combinations H/F								
CMG	P	Q	R	S	U	V	X	Z	Piede / Foot		F105	F120	F140	F160	F200	F250	F300
									Tipo / Type	Peso / Weight [kg]							
002	18	60	80	9	100	10	60	120	H60	0.2	•	•	•				
	18	80	104	9	110 - 120	10	75	145	H75	0.3	•	•	•				
	18	50 - 87	110	9	110	10	85	135	H85	0.4	•	•	•				

■ Preferenziale / Preferred

• Combinazioni possibili H/F / Possible combinations H/F

Versione F / F Version									
CMG	H	K	L	M	N f7	O	P	Flangia / Flange	
								Tipo / Type	Peso / Weight [kg]
002	3.5	7	105	85	70	6.5	90	F105	0.1
	3.5	8	120	100	80	7	100	F120	0.2
	3.5	8	140	115	95	9	115	F140	0.2

Motoriduttori CC ad assi ortogonali
DC helical bevel gearmotors

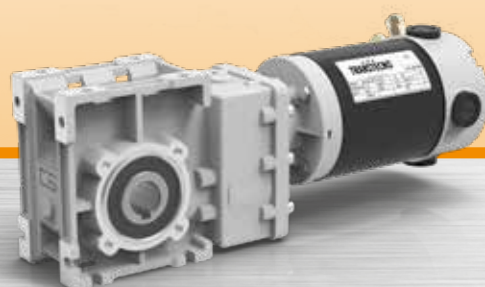

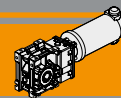

Indice	Index	Pag. Page
Caratteristiche tecniche	<i>Technical features</i>	BE2
Designazione	<i>Classification</i>	BE2
Sensi di rotazione	<i>Direction of rotation</i>	BE3
Simbologia	<i>Symbols</i>	BE3
Lubrificazione	<i>Lubrication</i>	BE3
Carichi radiali	<i>Radial loads</i>	BE3
Dati tecnici per servizio S2	<i>Technical data for S2 duty</i>	BE4
Motori applicabili	<i>Motor adapters</i>	BE6
Dimensioni	<i>Dimensions</i>	BE6
Accessori	<i>Accessories</i>	BE12

Questa sezione annulla e sostituisce ogni precedente edizione o revisione. Qualora questa sezione non Vi sia giunta in distribuzione controllata, l'aggiornamento dei dati ivi contenuto non è assicurato. **In tal caso la versione più aggiornata è disponibile sul nostro sito internet www.transtecno.com**

This section replaces any previous edition and revision. If you obtained this catalogue other than through controlled distribution channels, the most up to date content is not guaranteed. In this case the latest version is available on our web site www.transtecno.com

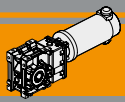

**NDCMB
ECMB**

**Motoriduttori CC ad assi ortogonali
DC Helical bevel gearmotors**



Caratteristiche tecniche

Technical features

I motoriduttori CC ortogonali a magneti permanenti in neodimio **NDCMB** e in ferrite **ECMB** hanno le seguenti caratteristiche principali:

NDCMB neodymium permanent magnets and ECMB ferrite permanent magnets DC helical bevel gearmotors range has the following main features:

- Alimentazione in bassa tensione 12/24 Vcc
- Possibilità di montaggio encoder e freno
- Potenze motore disponibili da 100 a 800W S2
- Carcasse dei riduttori in pressofusione di alluminio
- Lubrificazione permanente con olio sintetico
- Ingranaggi cilindrici a denti elicoidali, induriti e rettificati

- Low voltage power supply 12/24 Vdc
- Suitable for encoder and brake assembly
- Motor power ratings available from 100 to 800W S2
- Die-cast aluminum housing
- Permanent synthetic oil long-life lubrication
- Ground-hardened helical gears

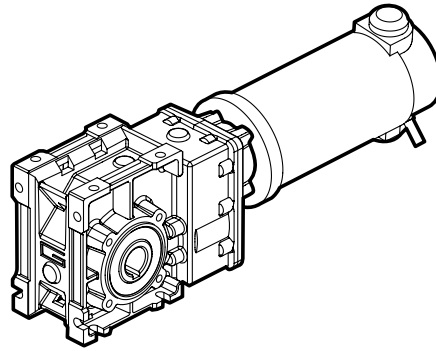

Designazione

Classification

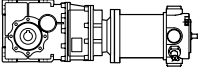
MOTORIDUTTORE / GEARMOTOR								
NDCMB	120/402	U	9.2	D20	SZDX	BRSX	90	240
Tipo Type	Grandezza Size	Versione Riduttore Gearbox Version	Rapporto Ratio	Albero di uscita Output shaft	Albero di uscita Output shaft	Braccio di reazione Torque arm	Angolo Angle	Versione Motore Motor Version
NDCMB 	120/402 180/402	U FD FS FLD FLS FBD FBS	Vedere tabella See tables	Vedere tabella See tables	SZDX SZSX DZ	BRDX BRSX *	0° 90° 180° 270°	120 240

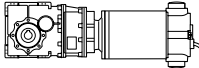
MOTORIDUTTORE / GEARMOTOR								
ECMB	100/402	U	9.2	D20	SZDX	BRSX	90	240
Tipo Type	Grandezza Size	Versione Riduttore Gearbox Version	Rapporto Ratio	Albero di uscita Output shaft	Albero di uscita Output shaft	Braccio di reazione Torque arm	Angolo Angle	Versione Motore Motor Version
ECMB 	070/402 100/402 180/402 250/402 350/402 600/402	U FD FS FLD FLS FBD FBS	Vedere tabella See tables	Vedere tabella See tables	SZDX SZSX DZ	BRDX BRSX *	0° 90° 180° 270°	120 240 24E

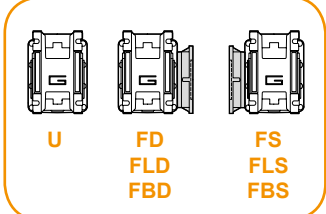
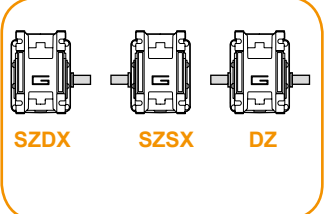
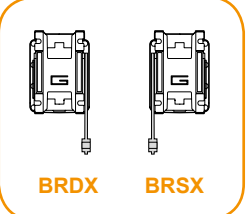
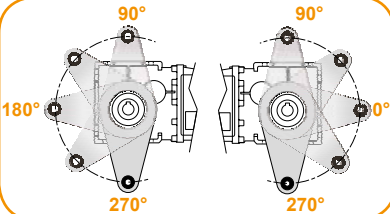
Versione Riduttore Gearbox Version	Albero di uscita Output shaft	Braccio di reazione Torque arm *	Angolo Angle
			

* NOTA: il braccio di reazione viene fornito smontato.
NOTE: the torque arm will be supplied not assembled.

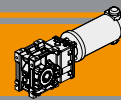

Sensi di rotazione

Direction of rotation

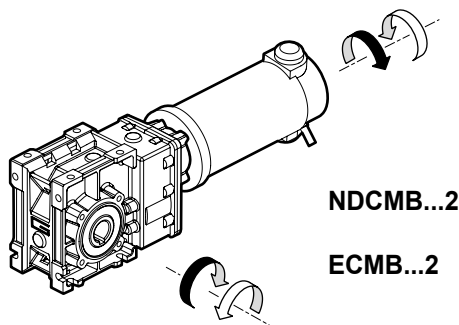

Simbologia

Symbols

n_1 [min ⁻¹]	Velocità in ingresso / <i>Input speed</i>	M_2 [Nm]	Coppia in uscita in funzione di P_1 / <i>Output torque referred to P_1</i>
n_2 [min ⁻¹]	Velocità in uscita / <i>Output speed</i>	sf	Fattore di servizio / <i>Service factor</i>
i	Rapporto di riduzione / <i>Ratio</i>	A_2 [N]	Carico assiale ammissibile in uscita / <i>Permitted output axial load</i>
P_1 [kW]	Potenza in entrata / <i>Input power</i>	R_2 [N]	Carico radiale ammissibile in uscita / <i>Permitted output radial load</i>

Lubrificazione

Lubrication

Tutti i riduttori nelle taglie 402 sono forniti completi di lubrificante sintetico viscosità 320, pertanto possono essere installati in qualunque posizione di montaggio e non necessitano di manutenzione.

Permanent synthetic oil long-life lubrication (viscosity grade 320) makes it possible to use sizes 402 in all mounting positions; for this reason they can be installed in any assembly position and do not require maintenance.

Carichi radiali

Radial loads

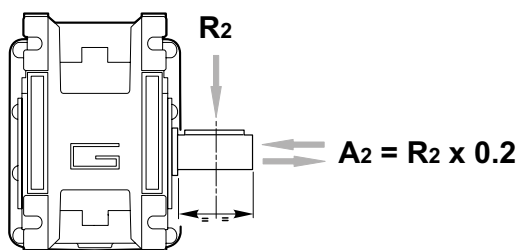

n_2 [min ⁻¹]	R_2 [N]
	CMB 402
400	905
300	996
200	1141
170	1204
140	1414
100	1582
90	1638
60	2047
40	2524
30	2778
20	3180
15	3500
10	3500

Quando il carico radiale risultante non è applicato sulla mezza-ria dell'albero occorre calcolare quello effettivo con la seguente formula:

When the resulting radial load is not applied on the centre line of the shaft it is necessary to calculate the effective load with the following formula:

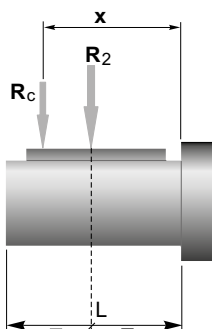

	CMB 402
a	86
b	66
R_{2MAX}	3500

$$R_c = \frac{R_2 \cdot a}{(b+x)} \leq R_{2MAX}$$

$$R \leq R_c$$

*a, b = valori riportati nella tabella
a, b = values given in the table*

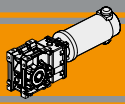

Dati tecnici per servizio S2

NDCMB

Technical data for S2 duty

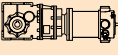
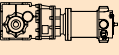
P_1 [W]	n_2 [min ⁻¹]	M_2 [Nm]	sf	i		Versione motore Motor version	P_1 [W]	n_2 [min ⁻¹]	M_2 [Nm]	sf	i		Versione motore Motor version
160							250						
(3000 min ⁻¹)	485	3.0	10.5	6.18	120/402	120/240	(3000 min ⁻¹)	485	4.6	6.7	6.18	180/402	120/240
	401	3.6	8.6	7.49									
	326	4.4	7.0	9.20									
	254	5.7	6.2	11.83									
	240	6.0	5.9	12.48									
	202	7.1	4.9	14.83									
	170	8.4	4.1	17.63									
	161	8.9	4.8	18.60									
	134	10	4.0	22.33									
	125	11	3.8	23.91									
	104	14	3.7	28.89									
	97	15	3.5	30.84									
	89	16	3.2	33.57									
	84	17	3.0	35.63									
	70	21	2.5	42.75									
	54	27	1.9	55.31									
	51	29	1.8	59.06									
	47	31	1.7	64.29									
	41	35	1.5	72.50									

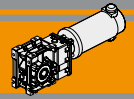

Dati tecnici per servizio S2

ECMB

Technical data for S2 duty

P ₁ [W]	n ₂ [min ⁻¹]	M ₂ [Nm]	sf	i		Versione motore Motor version
100						
(3000 min ⁻¹)	485	1.8	16.8	6.18	070/402	12E/24E
	401	2.2	13.8	7.49		
	326	2.8	11.3	9.20		
	254	3.5	9.9	11.83		
	240	3.7	9.4	12.48		
	202	4.4	7.9	14.83		
	170	5.3	6.6	17.63		
	161	5.6	7.7	18.60		
	134	6.7	6.4	22.33		
	125	7.2	6.0	23.91		
	104	8.6	5.9	28.89		
	97	9.2	5.5	30.84		
	89	10	5.1	33.57		
	84	11	4.8	35.63		
	70	13	4.0	42.75		
	54	17	3.1	55.31		
	51	18	2.9	59.06		
	47	19	2.7	64.29		
	41	22	2.4	72.50		

P ₁ [W]	n ₂ [min ⁻¹]	M ₂ [Nm]	sf	i		Versione motore Motor version
350						
(3000 min ⁻¹)	485	6.5	4.8	6.18	250/402	120/240
	401	7.8	4	7.49		
	326	9.6	3.2	9.20		
	254	12	2.8	11.83		
	240	13	2.7	12.48		
	202	16	2.3	14.83		
	170	19	1.9	17.63		
	161	20	2.2	18.60		
	134	23	1.8	22.33		
	125	25	1.7	23.91		
	104	30	1.7	28.89		
	97	32	1.6	30.84		
	89	35	1.5	33.57		
	84	37	1.4	35.63		
	70	45	1.1	42.75		
	54	58	0.9	55.31		
	51	62	0.8	59.06		
	47	67	0.8	64.29		
	41	72	0.7	72.50		

140						
(3000 min ⁻¹)	485	2.6	12.0	6.18	100/402	120/240/24E
	401	3.1	9.9	7.49		
	326	3.9	8.0	9.20		
	254	5.0	7.1	11.83		
	240	5.2	6.7	12.48		
	202	6.2	5.6	14.83		
	170	7.4	4.7	17.63		
	161	7.8	5.5	18.60		
	134	9.4	4.6	22.33		
	125	10	4.3	23.91		
	104	12	4.2	28.89		
	97	13	3.9	30.84		
	89	14	3.6	33.57		
	84	15	3.4	35.63		
	70	18	2.8	42.75		
	54	23	2.2	55.31		
	51	25	2.1	59.06		
	47	27	1.9	64.29		
	41	30	1.7	72.50		

500						
(3000 min ⁻¹)	485	9	3.4	6.18	350/402	120/240
	401	11	2.8	7.49		
	326	14	2.3	9.2		
	254	18	2.0	11.83		
	240	19	1.9	12.48		
	202	22	1.6	14.83		
	170	26	1.3	17.63		
	161	28	1.5	18.6		
	134	33	1.3	22.33		
	125	36	1.2	23.91		
	104	43	1.2	28.89		
	97	46	1.1	30.84		
	89	50	1.0	33.57		
	84	53	1.0	35.63		
	70	64	0.8	42.75		
	54	73	0.7	55.31		
	51	73	0.7	59.06		
	47	73	0.7	64.29		

250						
(3000 min ⁻¹)	485	4.6	6.7	6.18	180/402	120/240/24E
	401	5.6	5.5	7.49		
	326	6.9	4.5	9.20		
	254	8.8	4.0	11.83		
	240	9.3	3.7	12.48		
	202	11	3.2	14.83		
	170	13	2.7	17.63		
	161	14	3.1	18.60		
	134	17	2.6	22.33		
	125	18	2.4	23.91		
	104	22	2.4	28.89		
	97	23	2.2	30.84		
	89	25	2.0	33.57		
	84	27	1.9	35.63		
	70	32	1.6	42.75		
	54	41	1.2	55.31		
	51	44	1.2	59.06		
	47	48	1.1	64.29		
	41	54	0.9	72.50		

800						
(3000 min ⁻¹)	485	15	2.1	6.18	600/402	120/240
	401	18	1.7	7.49		
	326	22	1.4	9.20		
	254	28	1.2	11.83		
	240	30	1.2	12.48		
	202	36	1.0	14.83		
	170	42	0.8	17.63		
	161	45	1.0	18.60		
	134	53	0.8	22.33		
	125	57	0.8	23.91		
	104	69	0.7	28.89		
	97	73	0.7	30.84		
	89	73	0.7	33.57		
	84	73	0.7	35.63		
	70	73	0.7	42.75		

NOTA
Verificare sempre che la coppia M₂ utilizzata non ecceda il valore indicato nelle caselle in grigio
NOTE
Please check that the output torque M₂ does not exceed the value in the grey areas

DC

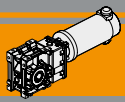

Motori applicabili

Motor adapters

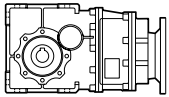
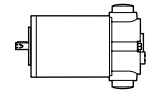
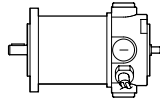

		ND		EC					
		120.120 120.240	180.120 180.240	070.12E 070.24E	100.120 100.240 100.24E	180.120 180.240 180.24E	250.120 250.240	350.120 350.240	600.120 600.240
CMB	402	6.18 - 72.50							

6.18 - 72.50

Rapporti di riduzione i
Ratio i

Dimensioni

Dimensions

NDCMB120/402 U
NDCMB180/402 U

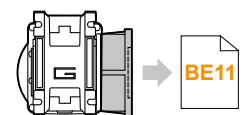
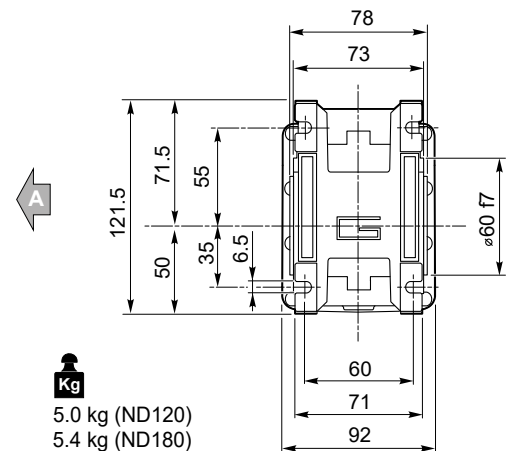
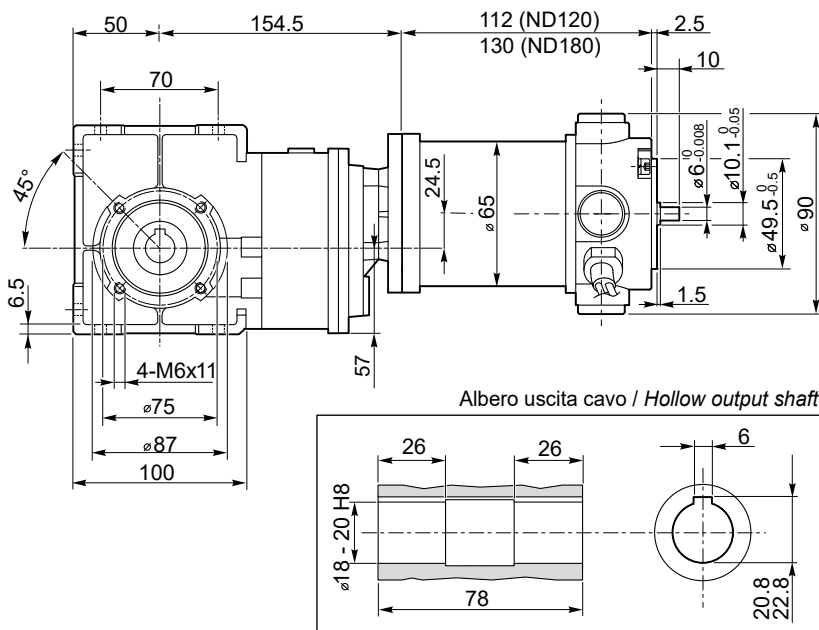

BE11

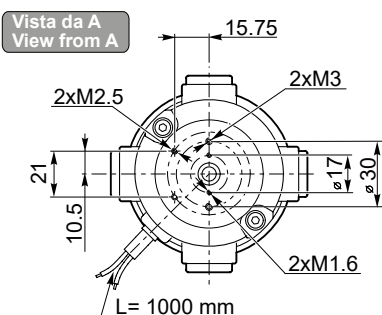

Freno / Brake

BA9



Encoder

BA9

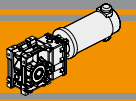

Dimensioni

Dimensions

ECMB070/402 U

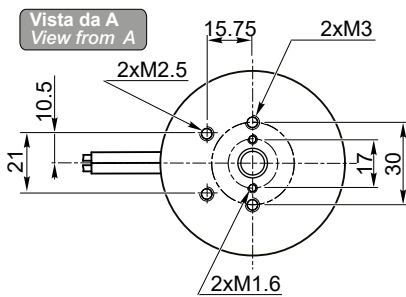
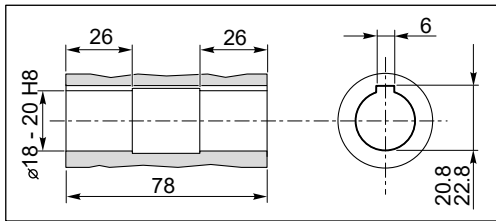
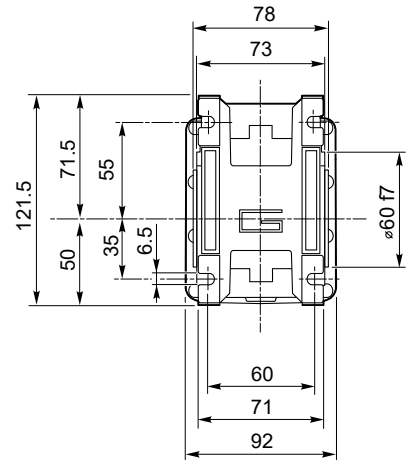
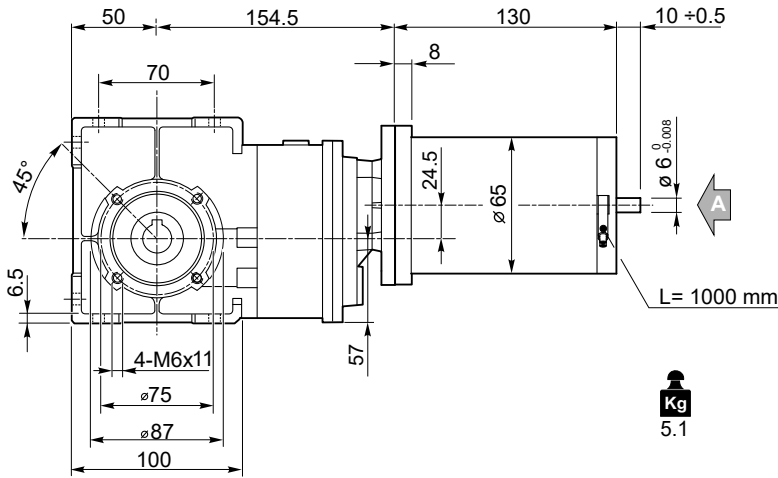

Freno / Brake → BB23

Encoder → BB24

Motori / Motors IP66 → BC2

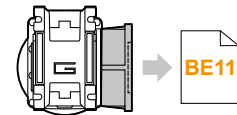

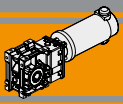

Dimensioni

Dimensions

ECMB100/402 U

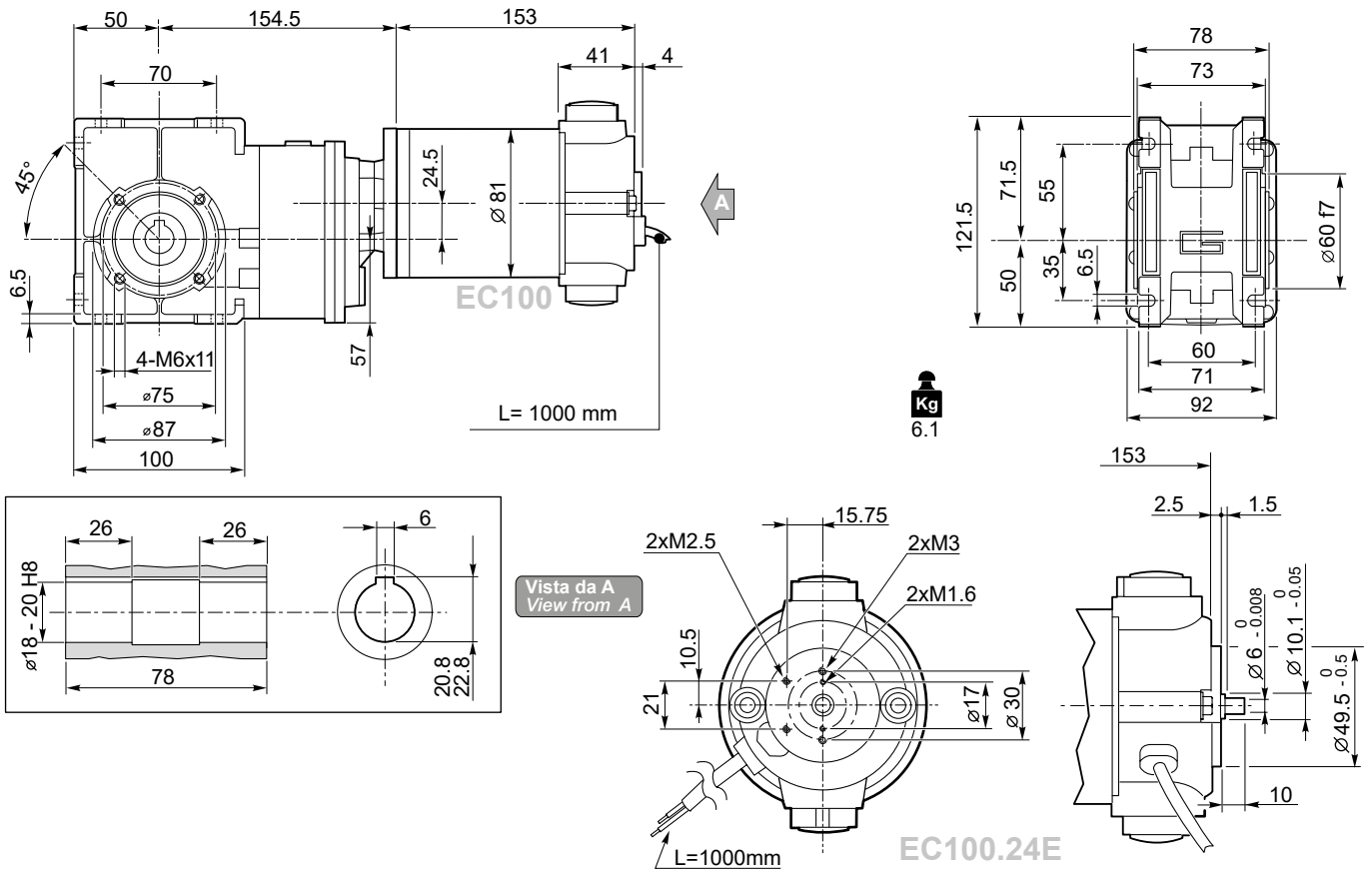

Motori / Motors IP66



Encoder



Freno / Brake

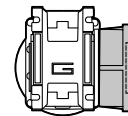

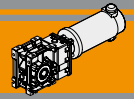

Dimensioni

Dimensions

ECMB180/402 U

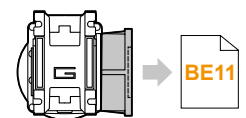
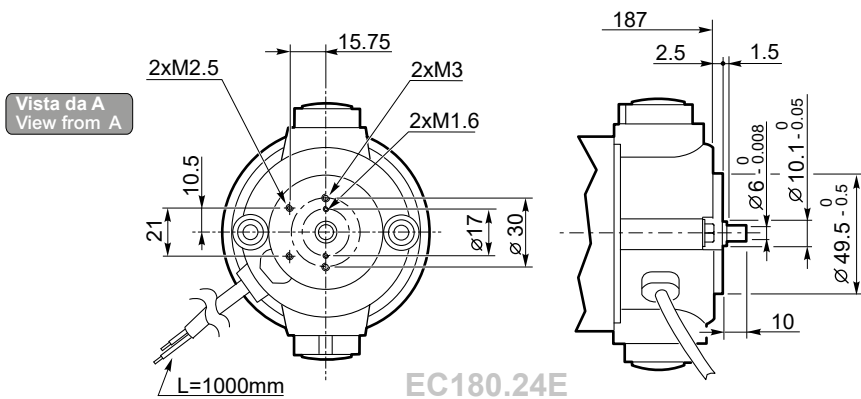
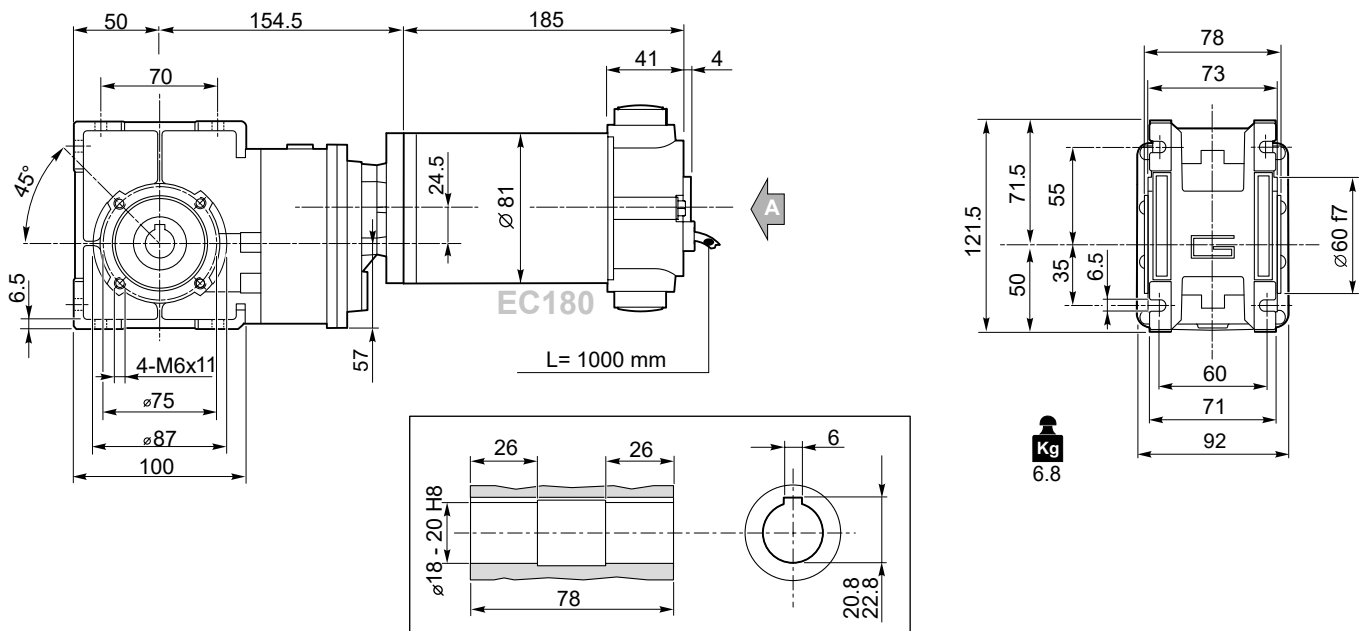

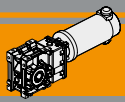

Dimensioni

Dimensions

ECMB250/402 U

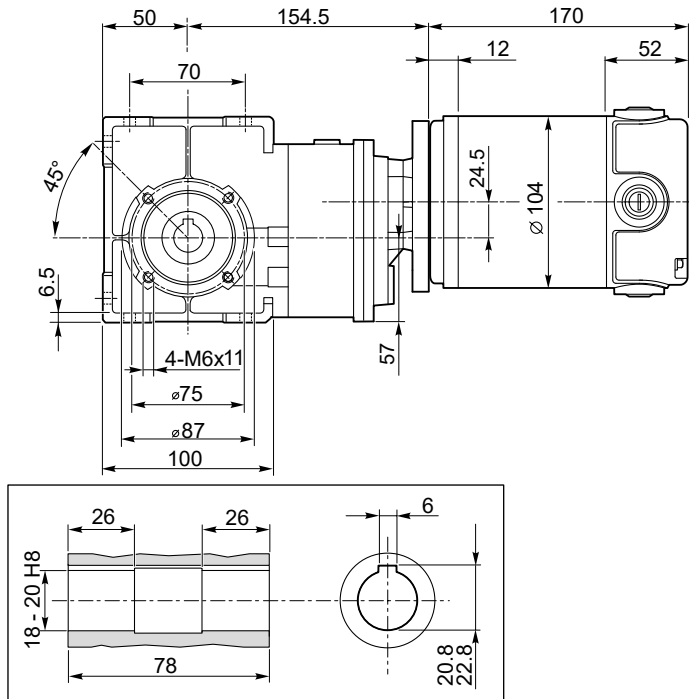

Kg
7.6

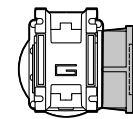
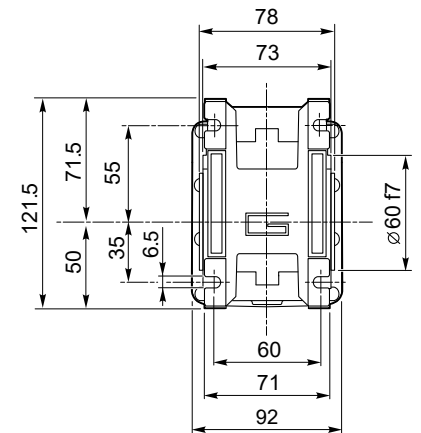

BE11

Motori / Motors IP66

BC8

ECMB350/402 U

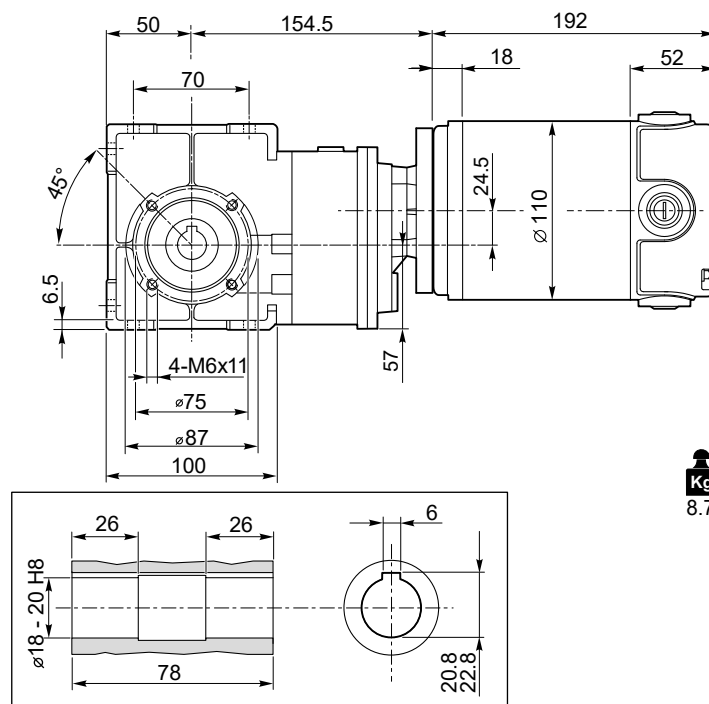

Kg
8.7

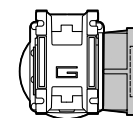
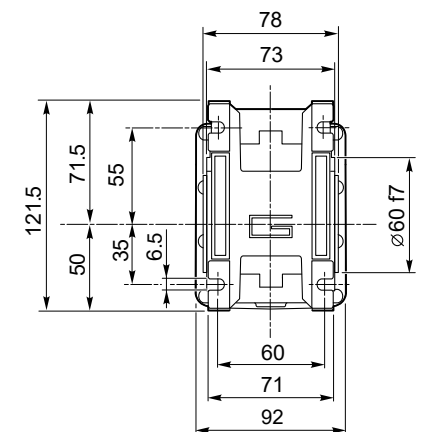

BE11

Freno / Brake

BB24

Motori / Motors IP66

BC10

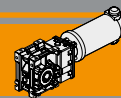

Dimensioni

Dimensions

ECMB600/402 U

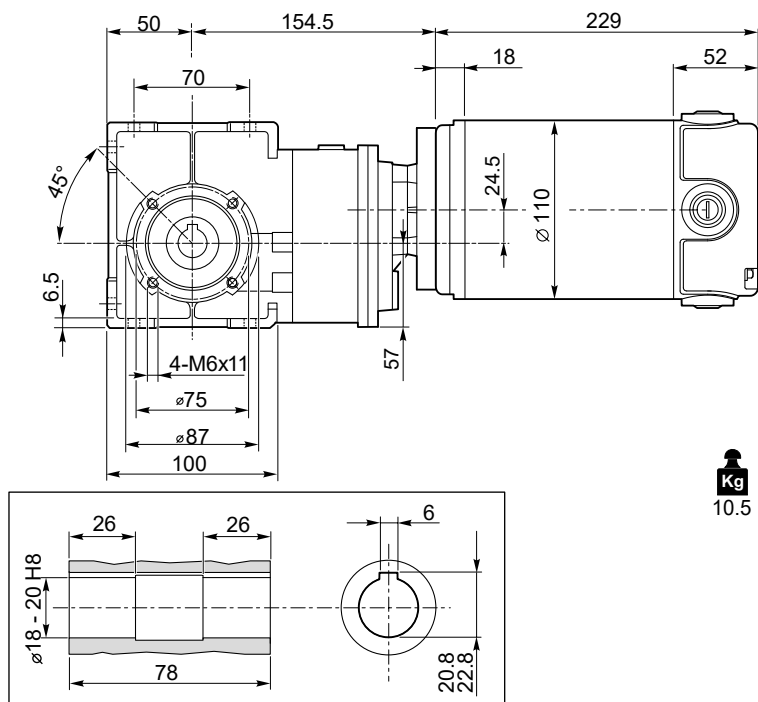

Kg
10.5

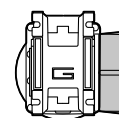
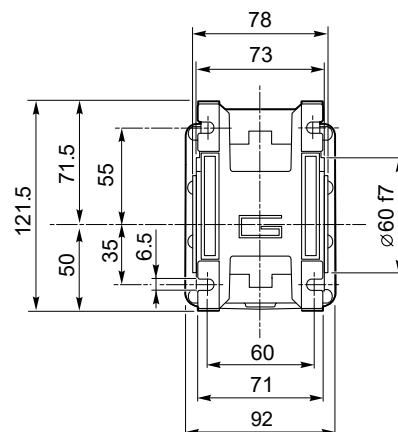

BE11

Freno / Brake

BB23

Motori / Motors IP66

BC12

NDCMB.../ F... - ECMB.../... F... Flange uscita / Output flanges

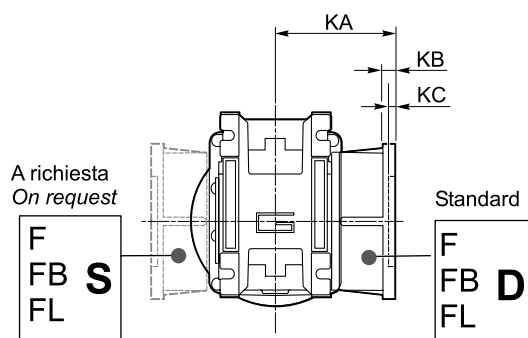
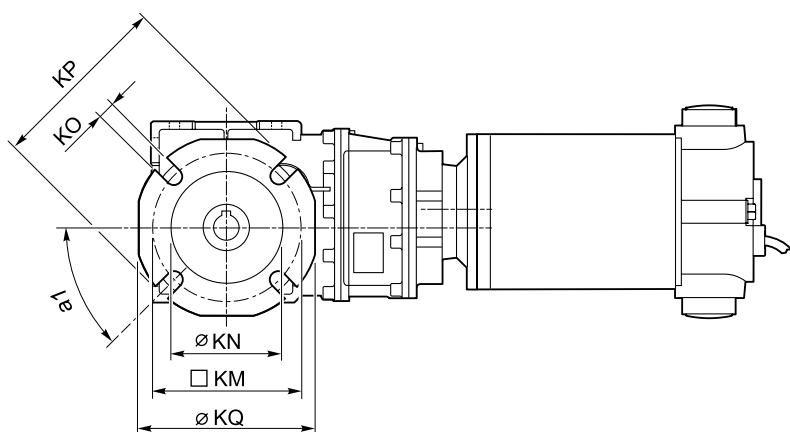

CMB	Flange uscita / Output flanges																										
	F					FL					FB																
	a ₁	KA	KB	KC	KM	KN H8	KO	KP	KQ	a ₁	KA	KB	KC	KM	KN H8	KO	KP	KQ	a ₁	KA	KB	KC	KM	KN H8	KO	KP	KQ
402	45°	67	7.5	4.5	80-95	60	9	110	95	45°	97	7.5	4.5	80-95	60	9	110	95	45°	80	8.5	5	115-125	95	9.5	140	112

DC

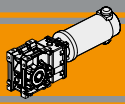

Accessori

Accessories

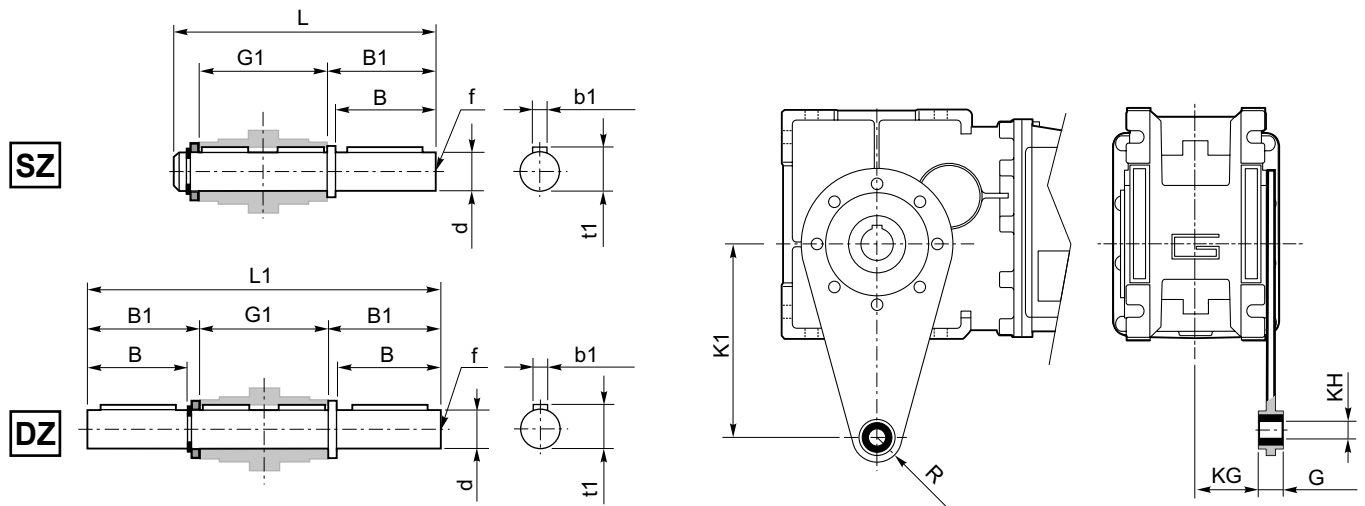

Albero lento / Output shaft

Braccio di reazione / Torque arm

CMB	d h7	B	B1	G1	L	L1	f	b1	t1
402	18	40	43	78	128	164	M6	6	20.5

CMB	K1	G	KG	KH	R
402	100	14	31	10	18

SC - Safety cover

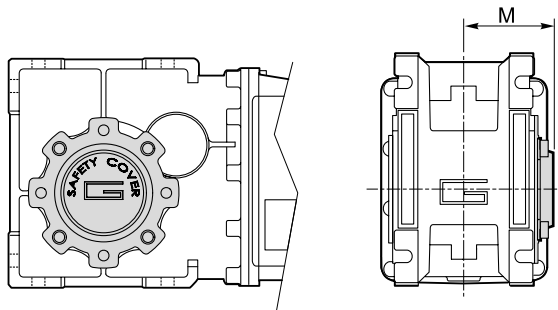

CMB	M
402	54.5

MINI 
TECNO
small but strong

NDFT
ECFT

Motoriduttori CC pendolari
DC Helical parallel gearmotors

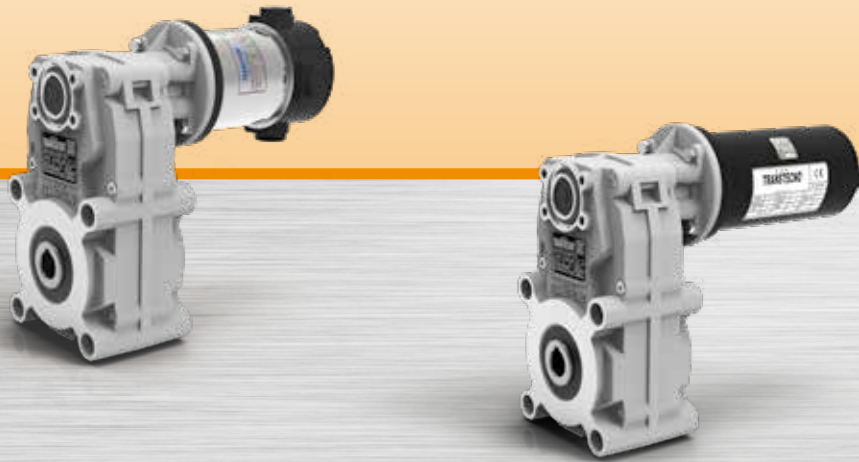

MINI 
TECNO brand of
TRANSTECNO



DC

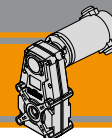

Indice	Index	Pag. Page
Caratteristiche tecniche	<i>Technical features</i>	BF2
Designazione	<i>Classification</i>	BF2
Sensi di rotazione	<i>Direction of rotation</i>	BF3
Simbologia	<i>Symbols</i>	BF3
Lubrificazione	<i>Lubrication</i>	BF3
Carichi radiali	<i>Radial loads</i>	BF4
Dati tecnici	<i>Technical data</i>	BF5
Motori applicabili	<i>Motor adapters</i>	BF6
Dimensioni	<i>Dimensions</i>	BF7

Questa sezione annulla e sostituisce ogni precedente edizione o revisione. Qualora questa sezione non Vi sia giunta in distribuzione controllata, l'aggiornamento dei dati ivi contenuto non è assicurato. **In tal caso la versione più aggiornata è disponibile sul nostro sito internet www.transtecno.com**

This section replaces any previous edition and revision. If you obtained this catalogue other than through controlled distribution channels, the most up to date content is not guaranteed. In this case the latest version is available on our web site www.transtecno.com

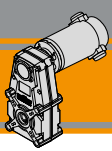
**NDFT
ECFT****Motoriduttori CC pendolari
DC Helical parallel gearmotors****Caratteristiche tecniche****Technical features**

I motoriduttori CC pendolari a magneti permanenti in neodimio **NDFT** e in ferrite **ECFT** hanno le seguenti caratteristiche principali:

NDFT neodymium permanent magnets and **ECFT** ferrite permanent magnets DC helical parallel gearmotors range has the following main features:

- Alimentazione in bassa tensione 12/24 Vcc
- Possibilità di montaggio encoder e freno
- Potenze motore disponibili da 100 a 800W S2
- Carcasse dei riduttori in pressofusione di alluminio
- Lubrificazione permanente con olio sintetico
- Ingranaggi cilindrici a denti elicoidali.

- Low voltage power supply 12/24 Vdc
- Suitable for encoder and brake assembly
- Motor power ratings available from 160 to 250W S2
- Die-cast aluminum housing
- Permanent synthetic oil long-life lubrication
- helical gears.

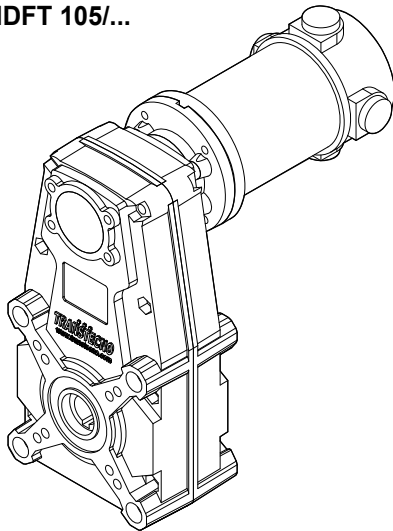
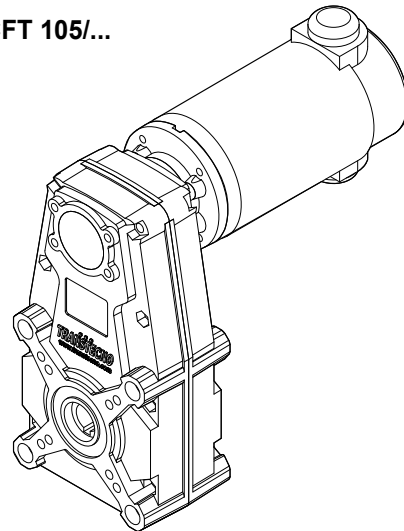
NDFT 105/...**ECFT 105/...****Designazione****Classification**

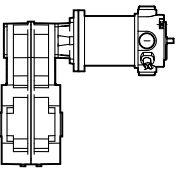
MOTORIDUTTORE / GEARMOTOR					
NDFT	120/146	U	60.63	O20	240
Tipo Type	Grandezza Size	Versione Riduttore Gearbox Version	Rapporto Ratio	Albero di uscita Output shaft	Versione Motore Motor Version
NDFT 	120/105/3 120/105/4 180/105/3	U...	Vedere tabella See tables	Vedere tabella See tables	120 240

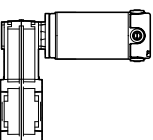
MOTORIDUTTORE / GEARMOTORS					
ECFT	180/146	U	60.63	O20	B5
Tipo Type	Grandezza Size	Versione Version	Rapporto Ratio	Albero cavo uscita Hollow output shaft	Versione motore Motor version
ECFT 	070/105/3 070/105/4 100/105/3 180/105/3	U...	vedi tabelle see tables	vedi tabelle see tables	120 240 12E 24E

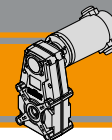

Sensi di rotazione

Direction of rotation

NDFT 105/3
ECFT 105/3

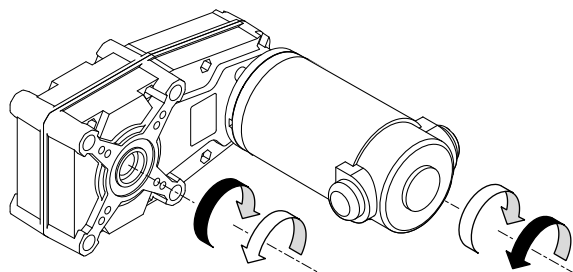
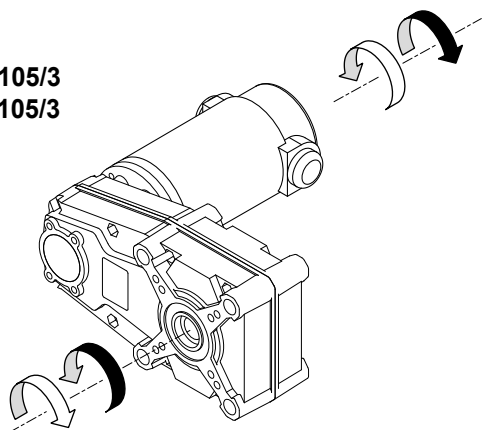

NDFT 105/4
ECFT 105/4

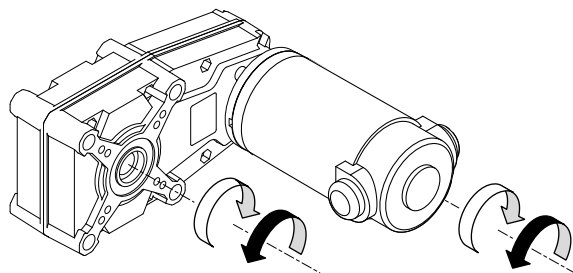
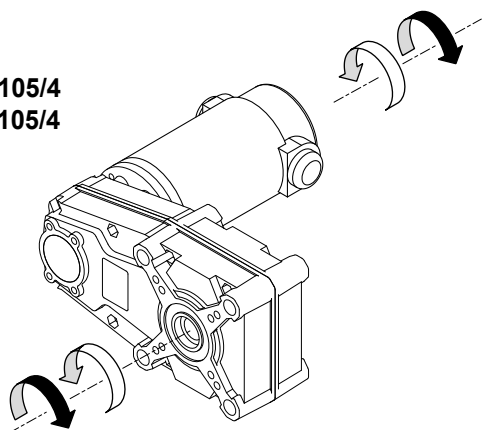

Simbologia

Symbols

n_1	[min^{-1}]	Velocità in ingresso / <i>Input speed</i>
n_2	[min^{-1}]	Velocità in uscita / <i>Output speed</i>
i		Rapporto di riduzione / <i>Ratio</i>
P_1	[kW]	Potenza in entrata / <i>Input power</i>
M_2	[Nm]	Coppia nominale in uscita in funzione di P_1 / <i>Output torque referred to P_1</i>
P_{n1}	[kW]	Potenza nominale in entrata / <i>Nominal input power</i>
M_{n2}	[Nm]	Coppia nominale in uscita in funzione di P_{n1} / <i>Nominal output torque referred to P_{n1}</i>
sf		Fattore di servizio / <i>Service factor</i>
R_2	[N]	Carico radiale ammissibile in uscita / <i>Permitted output radial load</i>
A_2	[N]	Carico assiale ammissibile in uscita / <i>Permitted output axial load</i>

Lubrificazione

Lubrication

Tutti i motoriduttori sono forniti completi di lubrificante sintetico viscosità 320, pertanto possono essere installati in qualunque posizione di montaggio e non necessitano di manutenzione.

Permanent synthetic oil long-life lubrication (viscosity grade 320) makes it possible to use the gearmotors in all mounting positions; for this reason they can be installed in any assembly position and do not require maintenance.

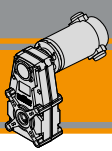

Carichi radiali

Radial loads

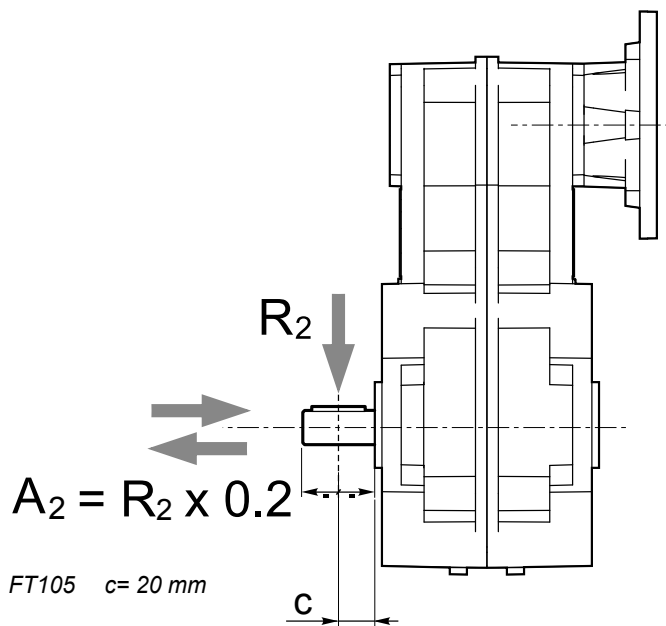

n_2 [min ⁻¹]	R_2 [N]
	FT105
70	1500
40	1700
30	1850
20	2000
10	2000
5	2000

Quando il carico radiale risultante non è applicato sulla mezzera dell'albero occorre calcolare quello effettivo con la seguente formula:

When the resulting radial load is not applied on the centre line of the shaft it is necessary to calculate the effective load with the following formula:

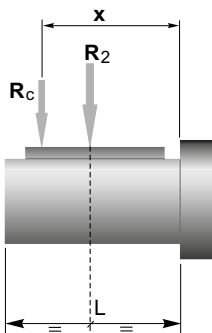



	FT105
a	82
b	62
R_{2MAX}	2000

$$R_c = \frac{R_2 \cdot a}{(b+x)} \leq R_{2MAX}$$

$$R \leq R_c$$

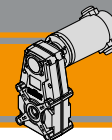
a, b = valori riportati nella tabella
a, b = values given in the table

Dati tecnici
NDFT
Technical data

P_1 [W]	n_2 [min ⁻¹]	M_2 [Nm]	sf	i		Versione motore Motor version	P_1 [W]	n_2 [min ⁻¹]	M_2 [Nm]	sf	i		Versione motore Motor version
160							250						
(3000 min ⁻¹)	146	10	3.2	20.57	120/105/3	120/240	(3000 min ⁻¹)	146	15	2.0	20.57	180/105/3	120/240
	90	16	2.4	33.32									
	68	21	2.4	44.36									
	55	26	1.9	54.87									
	42	34	1.5	71.84									
	39	37	1.4	77.07									
	34	43	1.2	88.87									
	24	60	0.8	124.81									
	17	86	0.6	181.35									
	13	86	0.6	224.32									
	9.5	86	0.6	315.05									
	8.1	86	0.6	368.19			120/105/4	120/240					
	5.6	86	0.6	534.98									
	4.5	86	0.6	661.76									
	3.2	86	0.6	929.40									



NOTA

Verificare sempre che la coppia M_2 utilizzata non ecceda il valore indicato nelle caselle in grigio

NOTE

Please check that the output torque M_2 does not exceed the value in the grey areas

Dati tecnici
ECFT
Technical data

P_1 [W]	n_2 [min ⁻¹]	M_2 [Nm]	sf	i		Versione motore Motor version	P_1 [W]	n_2 [min ⁻¹]	M_2 [Nm]	sf	i		Versione motore Motor version
100							250						
(3000 min ⁻¹)	146	6	5.1	20.57	070/105/3	12E/24E	(3000 min ⁻¹)	146	15	2.0	20.57	180/105/3	120/240
	90	10	3.9	33.32									
	68	13	3.8	44.36									
	55	16	3.1	54.87									
	42	21	2.4	71.84									
	39	23	2.2	77.07									
	34	27	1.9	88.87									
	24	37	1.4	124.81									
	17	54	0.9	181.35									
	13	67	0.8	224.32									
	9.5	86	0.6	315.05									
	8.1	86	0.6	368.19			070/105/4	12E/24E					
	5.6	86	0.6	534.98									
	4.5	86	0.6	661.76									
	3.2	86	0.6	929.40									
140													
(3000 min ⁻¹)	146	9	3.6	20.57	100/105/3	120/240/24E							
	90	14	2.8	33.32									
	68	19	2.7	44.36									
	55	23	2.2	54.87									
	42	30	1.7	71.84									
	39	32	1.6	77.07									
	34	37	1.4	88.87									
	24	52	1.0	124.81									
	16.5	76	0.7	181.35									

NOTA

Verificare sempre che la coppia M_2 utilizzata non ecceda il valore indicato nelle caselle in grigio

NOTE

Please check that the output torque M_2 does not exceed the value in the grey areas

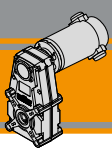

**NDFT
ECFT**

**Motoriduttori CC pendolari
DC Helical parallel gearmotors**



Motori applicabili

Motor adapters

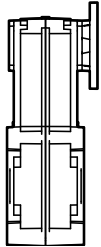
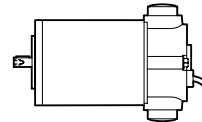
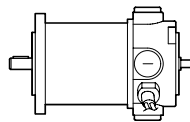

		ND		EC		
		120.120 120.240	180.120 180.240	070.12E 070.24E	100.120 100.240 100.24E	180.120 180.240
FT	105/3	20.57 - 315.05				
	105/4	368.19 - 929.4				

20.57 - 315.05

Rapporti di riduzione i
Ratio i

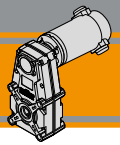

Dimensioni

Dimensions

NDFT 120/105

NDFT 120/105...U

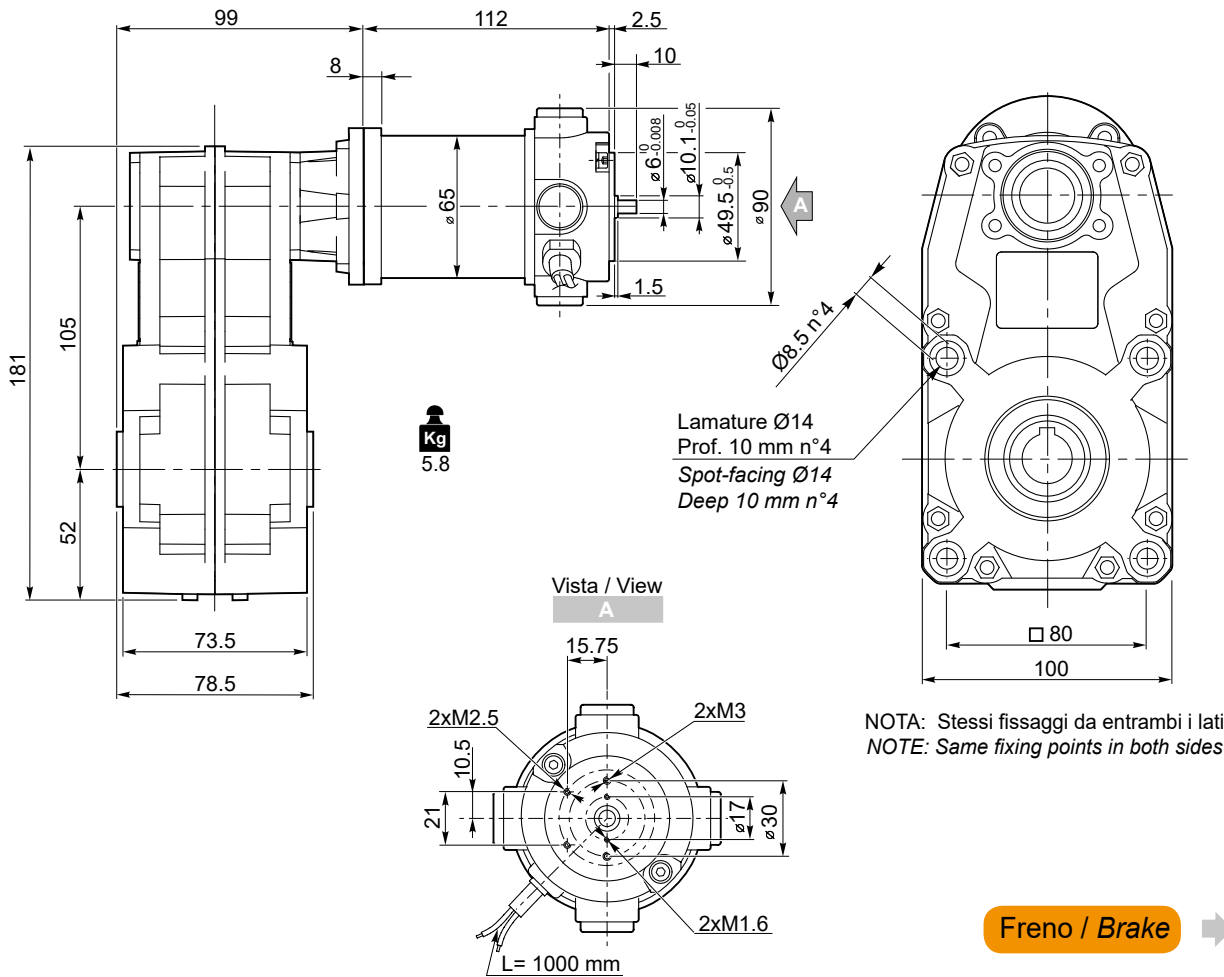

- Freno / Brake → BA9
- Encoder → BA9

O17

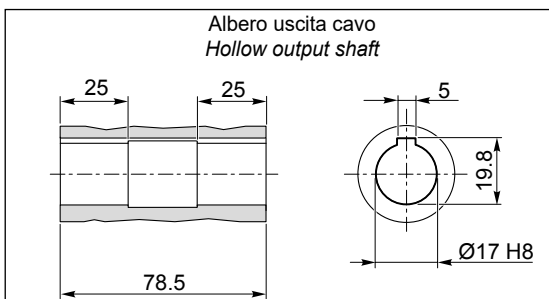

O20

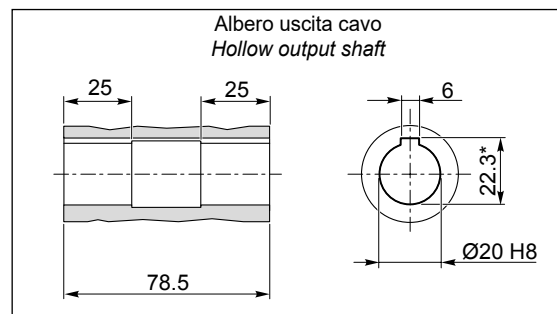

*: Sede linguetta ribassata / Special keyway

DC

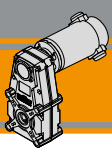

NDFT 180/105

NDFT 180/105...U

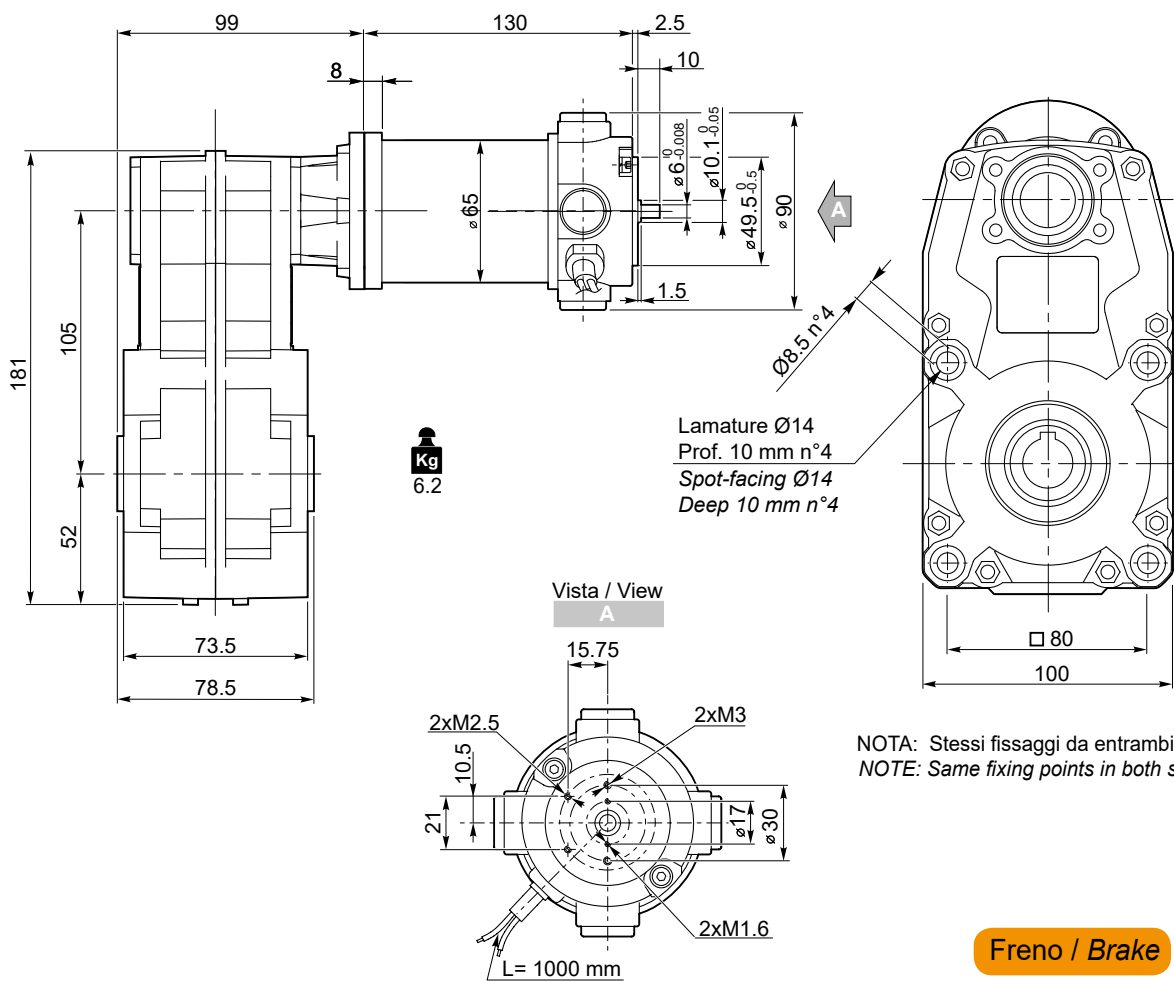

NOTA: Stessi fissaggi da entrambi i lati
NOTE: Same fixing points in both sides

- Freno / Brake ➔ BA9
- Encoder ➔ BA9

O17

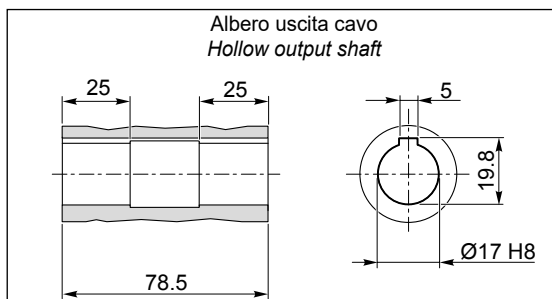

O20

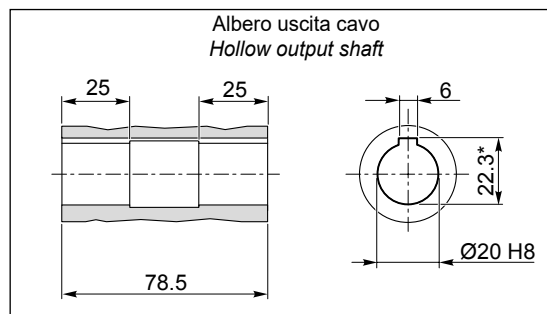

*: Sede linguetta ribassata / Special keyway

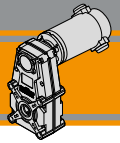

Dimensioni

Dimensions

ECFT 070/105

ECFT 070/105...U

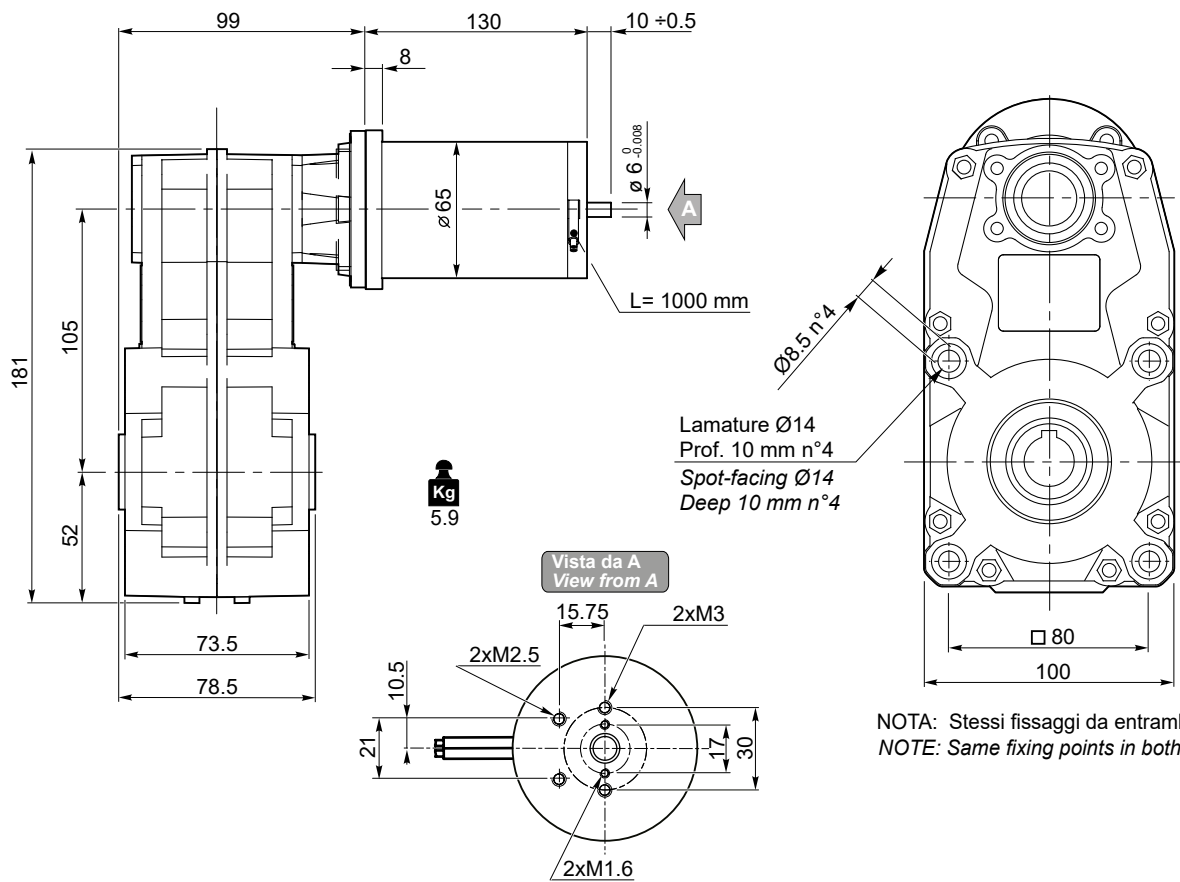

Freno / Brake → BB23

Encoder → BB24

Motori / Motors IP66 → BC2

O17

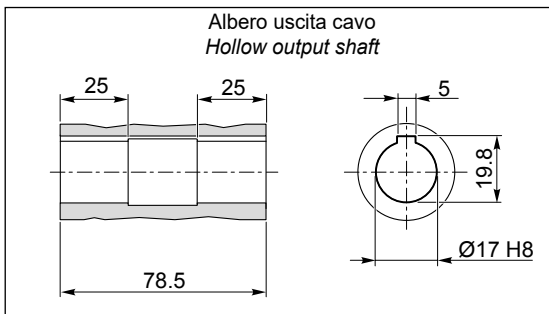

O20

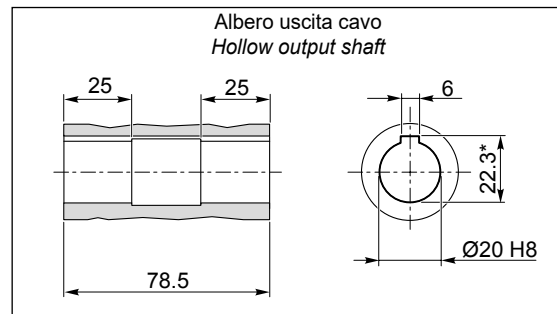

*: Sede linguetta ribassata / Special keyway

DC

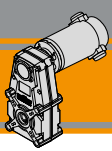

ECFT 100/105

ECFT 100/105...U

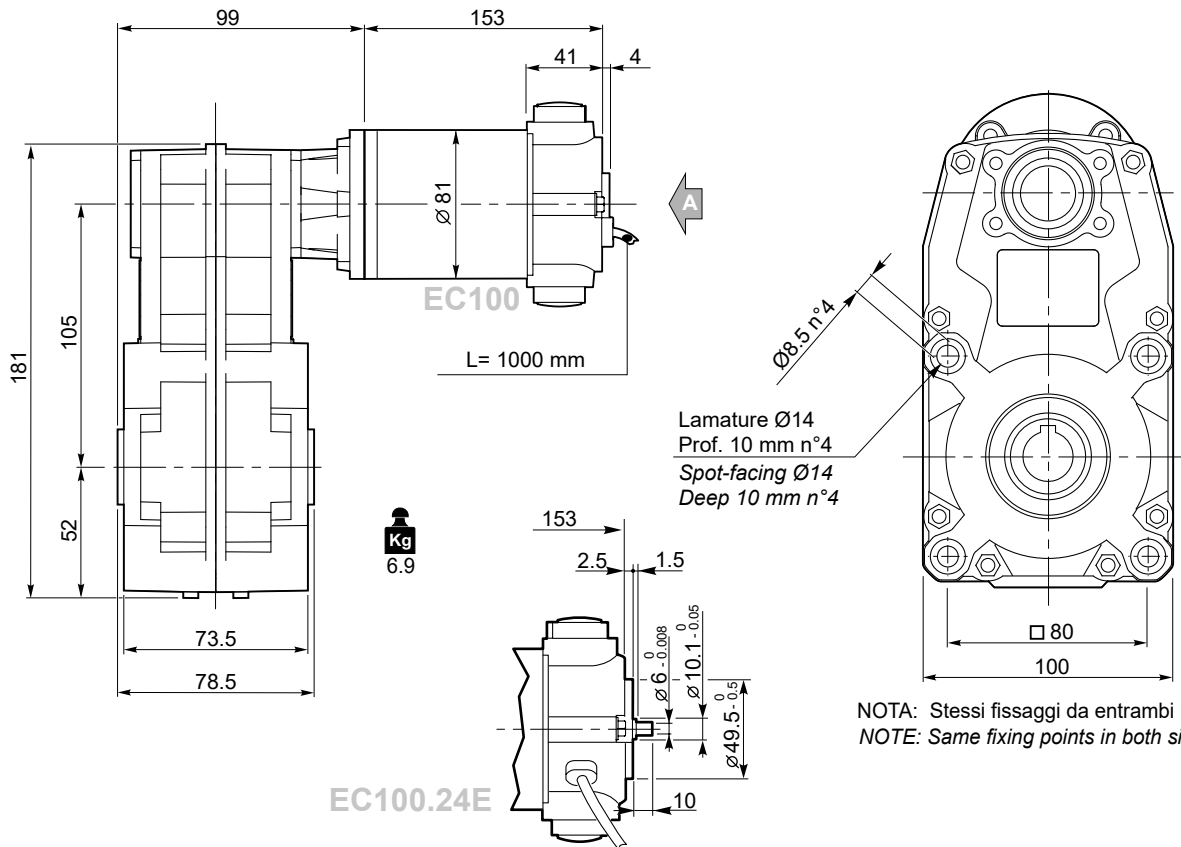

NOTA: Stessi fissaggi da entrambi i lati
NOTE: Same fixing points in both sides

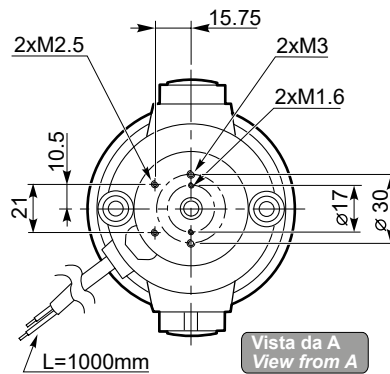

Freno / Brake → BB23

Encoder → BB24

Motori / Motors IP66 → BC4

O17

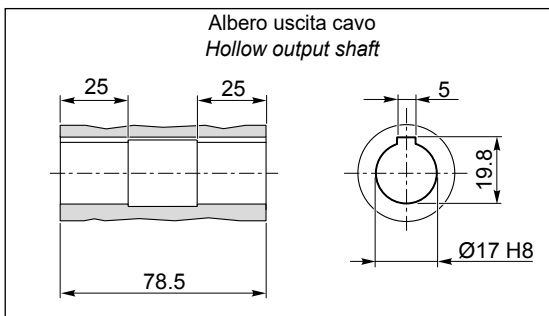

O20

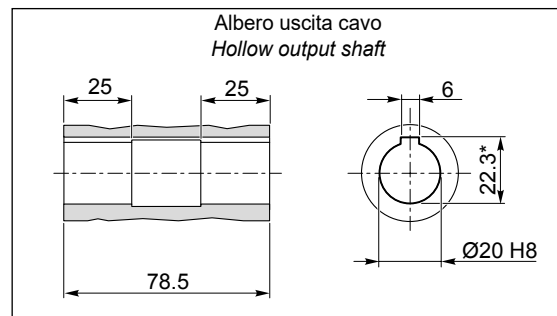

*: Sede linguetta ribassata / Special keyway

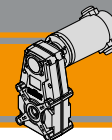

Dimensioni

Dimensions

ECFT 180/105

ECFT 180/105...U

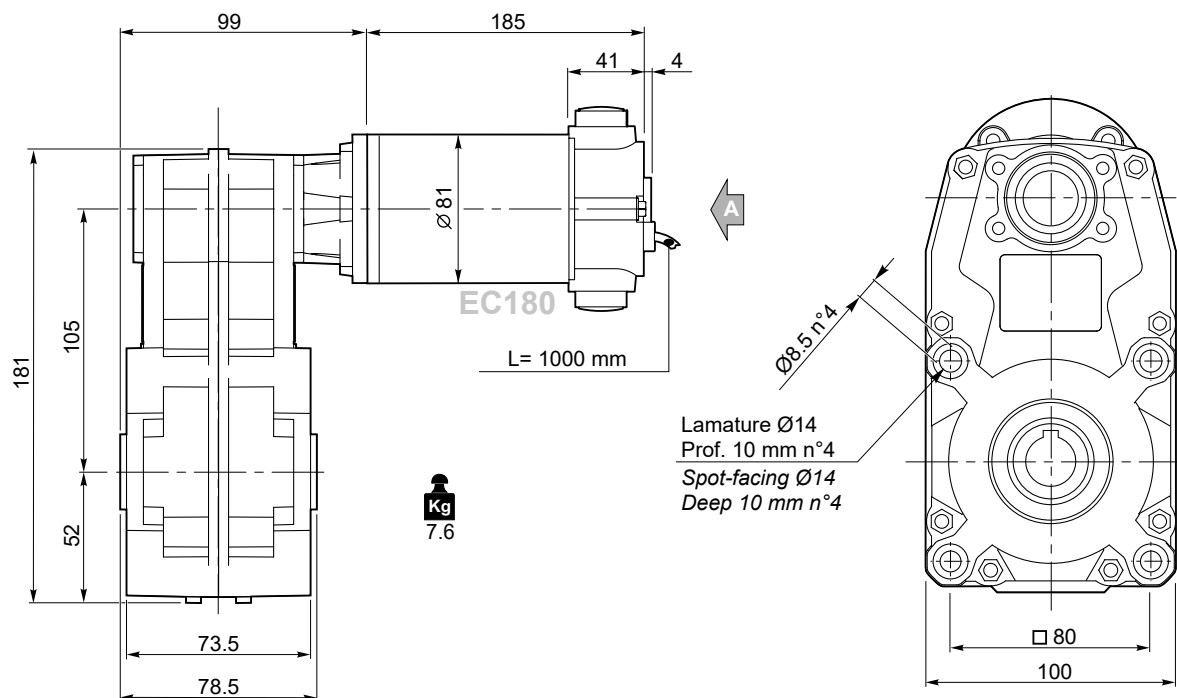

Lamature $\varnothing 14$
Prof. 10 mm n°4
Spot-facing $\varnothing 14$
Deep 10 mm n°4

NOTA: Stessi fissaggi da entrambi i lati
NOTE: Same fixing points in both sides

- Freno / Brake → BB23
- Encoder → BB24
- Motori / Motors IP66 → BC6

O17

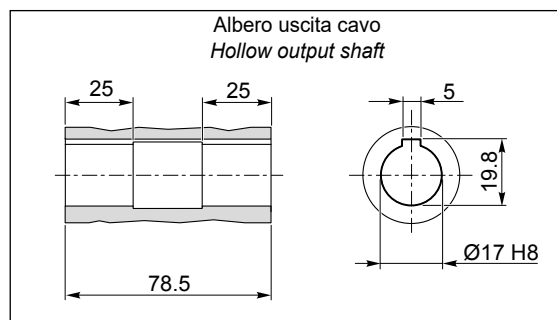

O20

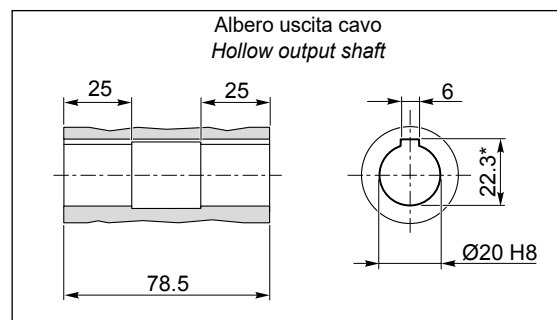

*: Sede linguetta ribassata / Special keyway

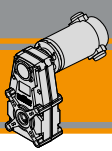

Note/Notes

MINI 
TECNO
small but strong

NDCM
ECM

Motoriduttori CC a vite senza fine
DC wormgearmotors



MINI 
TECNO brand of
TRANSTECNO



DC

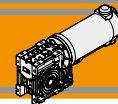

Indice	Index	Pag. Page
Caratteristiche tecniche	<i>Technical features</i>	BG2
Designazione	<i>Classification</i>	BG2
Simbologia	<i>Symbols</i>	BG3
Lubrificazione	<i>Lubrication</i>	BG3
Carichi radiali	<i>Radial loads</i>	BG3
Dati di dentatura	<i>Toothing data</i>	BG4
Rendimento	<i>Efficiency</i>	BG4
Dati tecnici per servizio S2	<i>Technical data for S2 duty</i>	BG5
Motori applicabili	<i>Motor adapters</i>	BG8
Dimensioni	<i>Dimensions</i>	BG8
Opzioni	<i>Options</i>	BG23
Accessori	<i>Accessories</i>	BG24

Questa sezione annulla e sostituisce ogni precedente edizione o revisione. Qualora questa sezione non Vi sia giunta in distribuzione controllata, l'aggiornamento dei dati ivi contenuto non è assicurato. **In tal caso la versione più aggiornata è disponibile sul nostro sito internet www.transtecno.com**

This section replaces any previous edition and revision. If you obtained this catalogue other than through controlled distribution channels, the most up to date content is not guaranteed. In this case the latest version is available on our web site www.transtecno.com

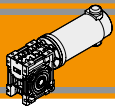

Caratteristiche tecniche

Technical features

I motoriduttori CC a vite senza fine a magneti permanenti in neodimio **NDCM** e in ferrite **ECM** hanno le seguenti caratteristiche principali:

NDCM neodymium permanent magnets and **ECM** ferrite permanent magnets DC wormgearmotors range has the following main features:

- Alimentazione in bassa tensione 12/24 Vcc
- Possibilità di montaggio encoder e freno
- Potenze motore disponibili da 100 a 800 W S2
- Carcasce dei riduttori in pressofusione di alluminio
- Lubrificazione permanente con olio sintetico
- Low voltage power supply 12/24 Vdc
- Suitable for encoder and brake assembly
- Motor power ratings available from 100 to 800 W S2
- Die-cast aluminum housing
- Permanent synthetic oil long life lubrication

Designazione

Classification

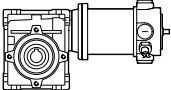
MOTORIDUTTORE / GEARMOTOR									
NDCM	120/030		U	10	SZDX	BRSX	90	240	VS
Tipo Type	Grandezza Size		Versione Riduttore Gearbox Version	Rapporto Ratio	Albero di uscita Output shaft	Braccio di reazione Torque arm	Angolo Angle	Versione Motore Motor Version	Opzioni Options
 <p>NDCM</p>	120/026	180/026	U F...	Vedere tabella See tables	SZDX SZSX DZ	BRDX BRSX	0° 90° 180° 270°	120 — 240	VS
	120/026 (D11)	180/026 (D11)							
	120/026 (D14)	180/026 (D14)							
	120/030	180/030							
	120/040	180/040				*			

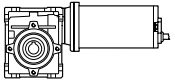
MOTORIDUTTORE / GEARMOTOR												
ECM	070/026					U	10	SZDX	BRSX	90	240	VS
Tipo Type	Grandezza Size					Versione Riduttore Gearbox Version	Rapporto Ratio	Albero di uscita Output shaft	Braccio di reazione Torque arm	Angolo Angle	Versione Motore Motor Version	Opzioni Options
 <p>ECM</p>	035/026	070/026	100/026	180/026	250/030	U F...	Vedere tabella See tables	SZDX SZSX DZ	BRDX BRSX	0° 90° 180° 270°	120	VS
	035/026 (D11)	070/026 (D11)	100/026 (D11)	180/026 (D11)	250/040							
	035/026 (D14)	070/026 (D14)	100/026 (D14)	180/026 (D14)								
	035/030	070/030	100/030	180/030	350/030							
			100/040	180/040	350/040							
	050/026				600/040							
050/026 (D11)												
050/026 (D14)												
050/030												

Versione Riduttore
Gearbox Version

Albero di uscita
Output shaft

Braccio di reazione
Torque arm *

Angolo
Angle

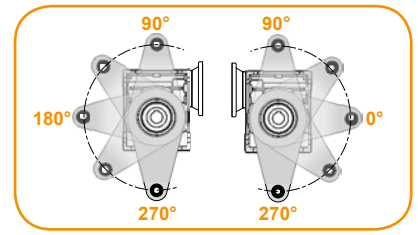
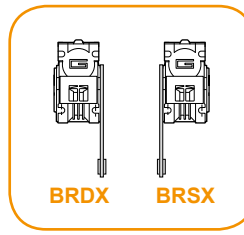
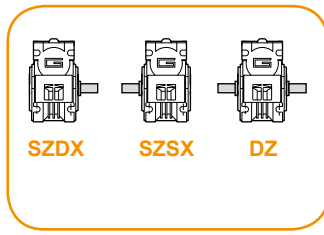
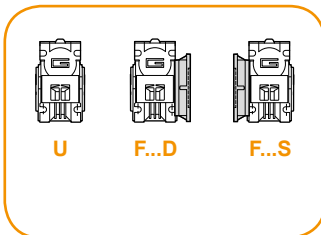

* NOTA: il braccio di reazione viene fornito smontato.
NOTE: the torque arm will be supplied not assembled.

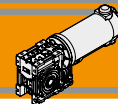

Simbologia

Symbols

n_1 [min ⁻¹]	Velocità in ingresso / <i>Input speed</i>	R_d %	Rendimento dinamico / <i>Dynamic efficiency</i>
n_2 [min ⁻¹]	Velocità in uscita / <i>Output speed</i>	A_2 [N]	Carico assiale ammissibile in uscita / <i>Permitted output axial load</i>
i	Rapporto di riduzione / <i>Ratio</i>	R_s %	Rendimento statico / <i>Static efficiency</i>
P_1 [kW]	Potenza in entrata / <i>Input power</i>	R_2 [N]	Carico radiale ammissibile in uscita / <i>Permitted output radial load</i>
M_2 [Nm]	Coppia in uscita in funzione di P_1 / <i>Output torque referred to P_1</i>	Z	Numero di principi della vite / <i>Worm starts</i>
sf	Fattore di servizio / <i>Service factor</i>	β	Angolo d'elica / <i>Helix angle</i>

Lubrificazione

Lubrication

I riduttori a vite senza fine della serie CM sono lubrificati a vita con olio sintetico di viscosità 320 e possono essere installati in qualunque posizione di montaggio.

Permanent synthetic oil long-life lubrication allow to use CM wormgearbox range in all mounting position.

Carichi radiali

Radial loads

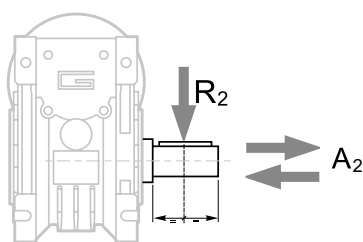

$$A_2 = R_2 \times 0.2$$

n_2 [min ⁻¹]	R_2 [N]		
	CM026	CM030	CM040
187	400	674	1264
140	490	743	1392
93	580	851	1596
70	610	936	1754
56	610	1008	1890
47	610	1069	2004
35	610	1179	2210
28	610	1270	2381
23	610	1356	2542
18	610	1471	2759
14	610	1600	3000

Quando il carico radiale risultante non è applicato sulla mezza-ria dell'albero occorre calcolare quello effettivo con la seguente formula:

When the resulting radial load is not applied on the centre line of the shaft it is necessary to calculate the effective load with the following formula:

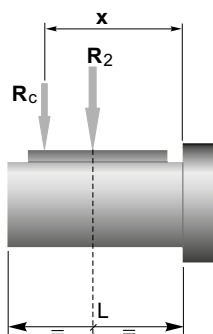

$$R_c = \frac{R_2 \cdot a}{(b + x)} \leq R_{2MAX}$$

$$R \leq R_c$$

*a, b = valori riportati nella tabella
a, b = values given in the table*

	CM		
	026	030	040
a	56	65	84
b	43	50	64
R_{2MAX}	610	1600	3000

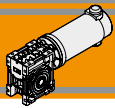

Dati di dentatura

Toothing data

	Dati della coppia vite-corona Worm wheel data	Rapporto / Ratio											
		5	7.5	10	15	20	25	30	40	50	60	80	100
CM026	Z	6	4	3	2	2		1	1	1	1		
	β	34° 35'	24° 41'	19° 1'	12° 57'	10° 30'		6° 33'	5° 17'	4° 26'	3° 49'		
CM030	Z	6	4	3	2	2	2	1	1	1	1	1	1
	β	27° 4'	24° 28'	18° 50'	12° 49'	10° 23'	8° 43'	6° 29'	5° 14'	4° 23'	3° 46'	2° 57'	2° 25'
CM040	Z	6	4	3	2	2	2	1	1	1	1	1	1
	β	34° 19'	24° 28'	18° 50'	12° 49'	10° 23'	8° 43'	6° 29'	5° 14'	4° 23'	3° 46'	2° 57'	2° 25'

Rendimento

Efficiency

	n_1 [min ⁻¹]	Rendimento Efficiency	Rapporto / Ratio												
			5	7.5	10	15	20	25	30	40	50	60	80	100	
CM026	2800	Rd	89	87	85	83	80		73	68	64	60			
			1400	87	84	83	78	74		66	61	57	53		
			900	84	83	80	75	71		61	57	52	48		
			Rs	72	71	68	61	56		46	41	36	34		
CM030	2800	Rd	89	88	86	84	81	78	74	70	65	62	57	52	
			1400	86	85	84	79	75	72	67	62	58	55	48	43
			900	84	83	81	75	71	68	62	58	53	49	43	39
			Rs	72	67	63	55	50	43	39	35	31	27	23	21
CM040	2800	Rd	90	89	87	84	83	80	77	73	69	66	60	56	
			1400	88	86	84	81	78	74	70	65	60	58	52	46
			900	86	84	82	77	74	70	66	60	57	53	46	41
			Rs	74	71	67	60	55	51	45	40	36	32	28	24



Rendimento teorico del riduttore dopo il rodaggio
Theoretical efficiency of the gearbox after the first running period

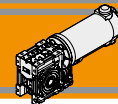

Dati tecnici per servizio S2

NDCM

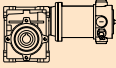
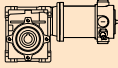

Technical data for S2 duty

P_1 [W]	n_2 [min ⁻¹]	M_2 [Nm]	sf	i		Versione motore Motor version	P_1 [W]	n_2 [min ⁻¹]	M_2 [Nm]	sf	i		Versione motore Motor version
160							250						
(3000 min ⁻¹)	600	2	4.4	5	120/026	120/240	(3000 min ⁻¹)	600	4	2.8	5	180/026	120/240
	400	3	3.3	7.5	120/026			400	5	2.1	7.5	180/026	
	300	4	2.5	10	120/026			300	7	1.6	10	180/026	
	200	6	1.7	15	120/026			200	10	1.1	15	180/026	
	150	8	1.3	20	120/026			150	13	0.9	20	180/026	
	100	11	1.1	30	120/026			100	17	0.7	30	180/026	
	75	14	0.8	40	120/026			75	16	0.7	40	180/026	
	60	14	0.7	50	120/026			60	14	0.7	50	180/026	
	50	13	0.7	60	120/026			50	13	0.7	60	180/026	
	600	2	5.7	5	120/030	120/240		600	4	3.7	5	180/030	120/240
	400	3	4.5	7.5	120/030			400	5	2.9	7.5	180/030	
	300	4	3.7	10	120/030			300	7	2.3	10	180/030	
	200	6	2.5	15	120/030			200	10	1.6	15	180/030	
	150	8	1.7	20	120/030			150	13	1.1	20	180/030	
	120	10	1.5	25	120/030			120	16	1.0	25	180/030	
	100	11	1.6	30	120/030			100	18	1.0	30	180/030	
	75	14	1.1	40	120/030			75	22	0.7	40	180/030	
	60	17	0.9	50	120/030			60	21	0.7	50	180/030	
	50	20	0.7	60	120/030			50	20	0.7	60	180/030	
	38	17	0.7	80	120/030			38	17	0.7	80	180/030	
	30	16	0.7	100	120/030			30	16	0.7	100	180/030	
	150	8	3.7	20	120/040	120/240		600	4	8.1	5	180/040	120/240
	120	10	2.7	25	120/040			400	5	5.8	7.5	180/040	
	100	12	3.2	30	120/040			300	7	4.8	10	180/040	
	75	15	2.3	40	120/040			200	10	3.5	15	180/040	
	60	18	1.8	50	120/040			150	13	2.3	20	180/040	
	50	20	1.4	60	120/040			120	16	1.8	25	180/040	
	38	24	1.1	80	120/040			100	18	2.1	30	180/040	
	30	29	0.8	100	120/040			75	23	1.5	40	180/040	
								60	27	1.2	50	180/040	
								50	32	0.9	60	180/040	
								38	38	0.7	80	180/040	
								30	34	0.7	100	180/040	

N.B.
Verificare sempre che la coppia M_2 utilizzata non ecceda il valore indicato nelle caselle in grigio

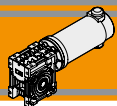
N.B.
Please check that the output torque M_2 does not exceed the value in the grey areas

**Dati tecnici per servizio S2****ECM****Technical data for S2 duty**

P_1 [W]	n_2 [min ⁻¹]	M_2 [Nm]	sf	i		Versione motore Motor version	P_1 [W]	n_2 [min ⁻¹]	M_2 [Nm]	sf	i		Versione motore Motor version
55							100						
(3000 min ⁻¹)	600	0.8	12.8	5	ECM035/026	120/240	(3000 min ⁻¹)	600	1.4	7.1	5	ECM070/026	12E/24E
	400	1.1	9.6	7.5				400	2.1	5.3	7.5		
	300	1.5	7.4	10				300	2.7	4.1	10		
	200	2.2	5.0	15				200	4.0	2.8	15		
	150	2.8	3.9	20				150	5.1	2.2	20		
	100	3.8	3.1	30				100	7.0	1.7	30		
	75	4.8	2.3	40				75	8.7	1.3	40		
	60	5.6	1.8	50				60	10	1.0	50		
	50	6.3	1.4	60				50	11	0.8	60		
	600	0.8	16.7	5			ECM035/030	120/240	600	1.4	9.2		
	400	1.2	13.0	7.5		400			2.1	7.1	7.5		
	300	1.5	10.6	10		300			2.7	5.8	10		
	200	2.2	7.3	15		200			4.0	4.0	15		
	150	2.8	4.9	20		150			5.2	2.7	20		
	120	3.4	4.4	25		120			6.2	2.4	25		
	100	3.9	4.6	30		100			7.1	2.5	30		
	75	4.9	3.3	40		75			8.9	1.8	40		
	60	5.7	2.6	50		60			10	1.4	50		
	50	6.5	2.1	60		50			12	1.2	60		
	38	8.0	1.5	80		38	15	0.8	80				
	30	9.1	1.2	100		30	17	0.7	100				
70							140						
(3000 min ⁻¹)	600	1.0	10.1	5	ECM050/026	120/240	(3000 min ⁻¹)	600	2.0	5.0	5	ECM100/026	120/240/24E
	400	1.5	7.6	7.5				400	2.9	3.8	7.5		
	300	1.9	5.8	10				300	3.8	2.9	10		
	200	2.8	4.0	15				200	5.5	2.0	15		
	150	3.6	3.1	20				150	7.1	1.5	20		
	100	4.9	2.5	30				100	10	1.2	30		
	75	6.1	1.8	40				75	12	0.9	40		
	60	7.1	1.4	50				60	14	0.7	50		
	50	8.0	1.1	60				50	13	0.7	60		
	600	1.0	13.1	5			ECM050/030	120/240	200	5.6	2.8		
	400	1.5	10.2	7.5		150			7.2	1.9	20		
	300	1.9	8.3	10		120			8.7	1.7	25		
	200	2.8	5.7	15		100			10	1.8	30		
	150	3.6	3.9	20		75			12	1.3	40		
	120	4.3	3.5	25		60			14	1.0	50		
	100	4.9	3.6	30		50			17	0.8	60		
	75	6.2	2.6	40		38			17	0.7	80		
	60	7.2	2.1	50		30			16	0.7	100		
	50	8.3	1.7	60		100			10	3.7	30	ECM100/040 120/240/24E	
	38	10.2	1.2	80		75	13	2.6	40				
	30	11.6	0.9	100		60	15	2.1	50				
						50	18	1.6	60				
						38	21	1.3	80				
						30	25	1.0	100				

NOTA
Verificare sempre che la coppia M2 utilizzata non ecceda il valore indicato nelle caselle in grigio

NOTE
Please check that the output torque M2 does not exceed the value in the grey areas

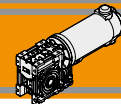

Dati tecnici per servizio S2

ECM

Technical data for S2 duty

P ₁ [W]	n ₂ [min ⁻¹]	M ₂ [Nm]	sf	i		Versione motore Motor version
-----------------------	--	------------------------	----	---	---	----------------------------------

P ₁ [W]	n ₂ [min ⁻¹]	M ₂ [Nm]	sf	i		Versione motore Motor version
-----------------------	--	------------------------	----	---	---	----------------------------------

250

(3000 min ⁻¹)	600	3.5	2.8	5	ECM180/026	120/240		
	400	5.2	2.1	7.5				
	300	6.8	1.6	10				
	200	10	1.1	15				
	150	13	0.9	20				
	100	17	0.7	30				
	75	16	0.7	40				
	60	14	0.7	50				
	50	13	0.7	60				
	600	3.5	3.7	5				
	400	5.3	2.9	7.5				
	300	6.8	2.3	10				
	200	10	1.6	15				
	150	13	1.1	20				
	120	16	1.0	25				
	100	18	1.0	30				
	75	22	0.7	40				
60	21	0.7	50					
50	20	0.7	60					
38	17	0.7	80					
30	16	0.7	100					
	600	3.5	3.7	5	ECM180/030	120/240/24E		
	400	5.3	2.9	7.5				
	300	6.8	2.3	10				
	200	10	1.6	15				
	150	13	1.1	20				
	120	16	1.0	25				
	100	18	1.0	30				
	75	22	0.7	40				
	60	21	0.7	50				
	50	20	0.7	60				
	38	17	0.7	80				
	30	16	0.7	100				
	200	10	3.5	15			ECM180/040	120/240/24E
	150	13	2.3	20				
	120	16	1.8	25				
	100	18	2.1	30				
	75	23	1.5	40				
	60	27	1.2	50				
	50	32	0.9	60				
	38	38	0.7	80				
	30	34	0.7	100				

500

(3000 min ⁻¹)	600	7.1	1.8	5	ECM350/030	120/240
	400	11	1.4	7.5		
	300	14	1.2	10		
	200	20	0.8	15		
	150	20	0.7	20		
	120	21	0.7	25		
	100	26	0.7	30		
	75	23	0.7	40		
	60	21	0.7	50		
	600	7.2	4.0	5		
	400	11	2.9	7.5		
	300	14	2.4	10		
	200	20	1.7	15		
	150	26	1.2	20		
	120	32	0.9	25		
	100	37	1.0	30		
	75	46	0.7	40		
60	46	0.7	50			
50	41	0.7	60			
38	39	0.7	80			
30	34	0.7	100			

800

(3000 min ⁻¹)	600	11	2.5	5	ECM600/040	120/240
	400	17	1.8	7.5		
	300	22	1.5	10		
	200	32	1.1	15		
	150	42	0.7	20		
	120	40	0.7	25		
	100	54	0.7	30		
	75	49	0.7	40		

350

(3000 min ⁻¹)	600	5.0	2.6	5	ECM250/030	120/240
	400	7.4	2.0	7.5		
	300	10	1.7	10		
	200	14	1.1	15		
	150	18	0.8	20		
	120	22	0.7	25		
	100	25	0.7	30		
	75	22	0.7	40		
	60	21	0.7	50		
	200	14	2.5	15		
	150	18	1.7	20		
	120	22	1.3	25		
	100	26	1.5	30		
	75	33	1.0	40		
	60	38	0.8	50		
	50	44	0.7	60		
	38	38	0.7	80		
30	35	0.7	100			

N.B.
Verificare sempre che la coppia M2 utilizzata non
ecceda il valore indicato nelle caselle in grigio
N.B.
Please check that the output torque M2 does not
exceed the value in the grey areas

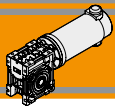

Motori applicabili

Motor adapters

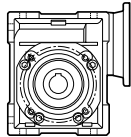
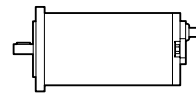
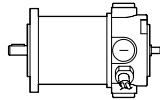

		ND		EC								
		120.120 120.240	180.120 180.240	035.12E 035.24E	050.12E 050.24E	070.12E 070.24E	100.120 100.240 100.24E	180.120 180.240	180.24E	250.120 250.240	350.120 350.240	600.120 600.240
CM	026	5-60	5-60	5-60	5-60	5-60	5-60	5-60				
	030	5-100	5-100	5-100	5-100	5-100	5-100	5-100	5-50	5-50	5-50	
	040	5-100	5-100				5-100	5-100	5-100	5-100	5-100	5-40

5-100

Rapporti di riduzione *i*
Ratio *i*

Dimensioni

Dimensions

NDCM120/026 U

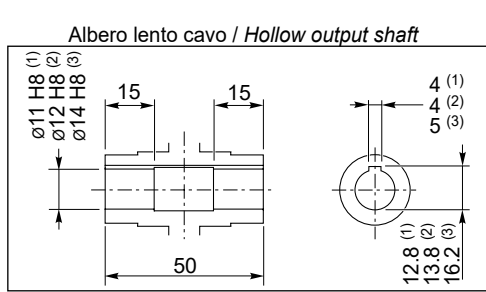
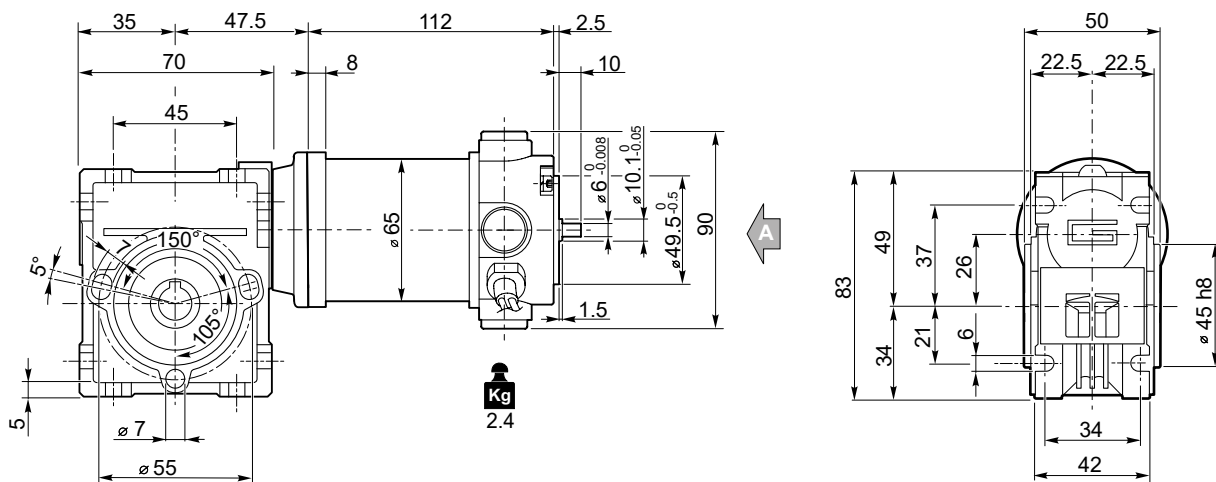

- (1): NDCM 120/026 (D11)
- (2): NDCM 120/026
- (3): NDCM 120/026 (D14)

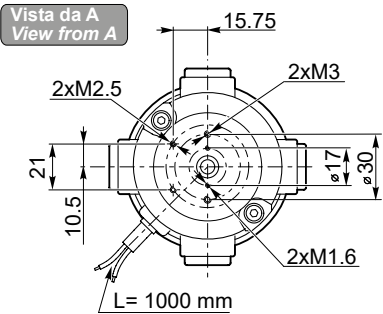

Freno / Brake → BA9

Encoder → BA9

BG22 → NDCM120/026 F...

II 6 → CL026

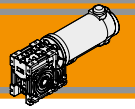

Dimensioni

Dimensions

NDCM120/030 U

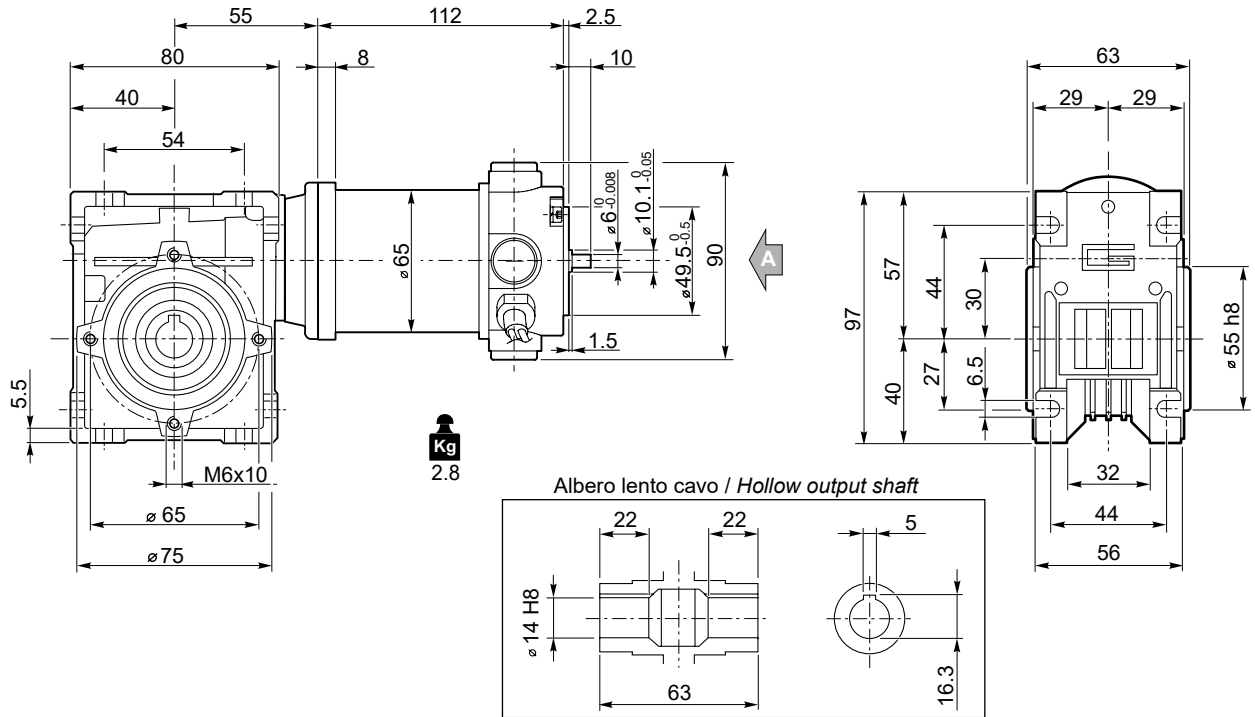

NDCM120/040 U

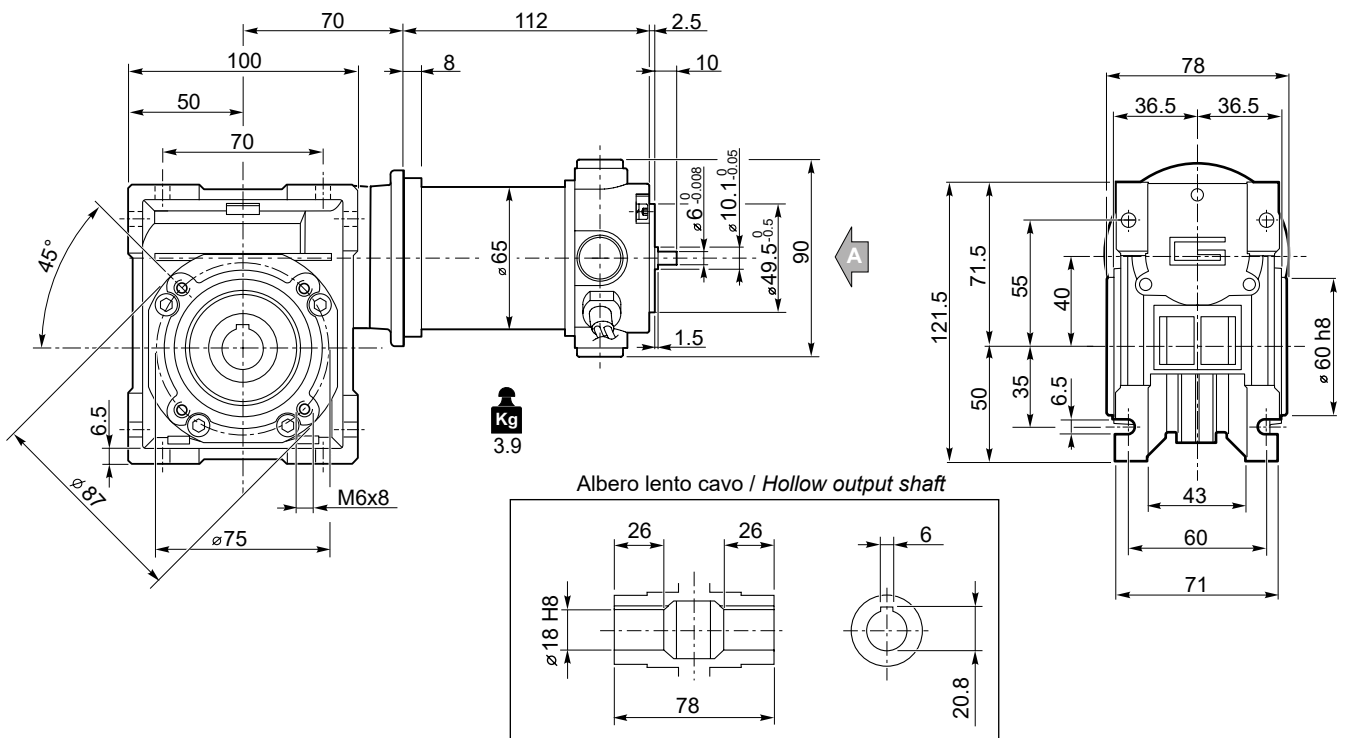

Vista da A
View from A

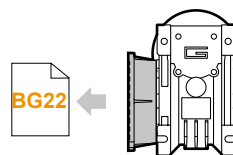
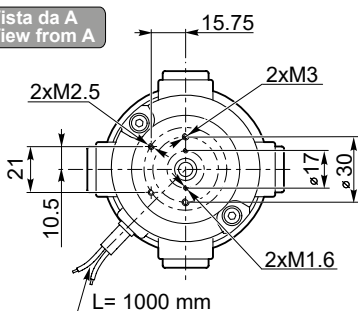

NDCM120/030 F
NDCM120/040 F...

Freno / Brake

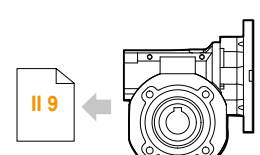

CL030
CL040

Encoder



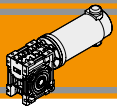

Dimensioni

Dimensions

NDCM180/026 U

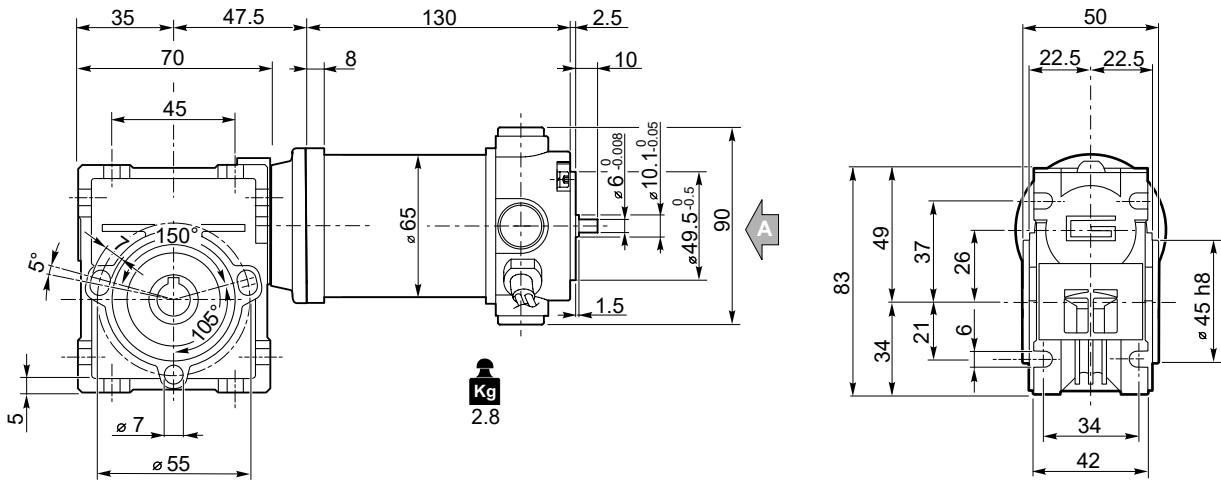

Albero lento cavo / Hollow output shaft

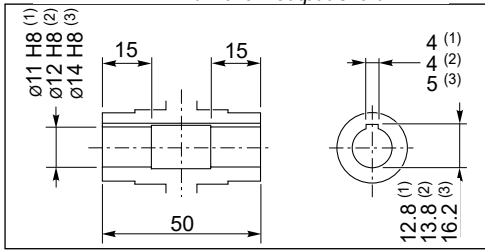

- (1): NDCM 180/026 (D11)
- (2): NDCM 180/026
- (3): NDCM 180/026 (D14)

Vista da A View from A

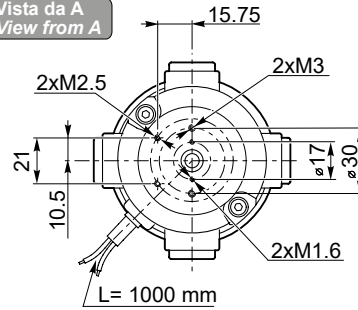

Freno / Brake



Encoder



NDCM180/026 F...

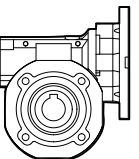

CL026

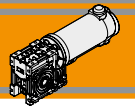

Dimensioni

Dimensions

NDCM180/030 U

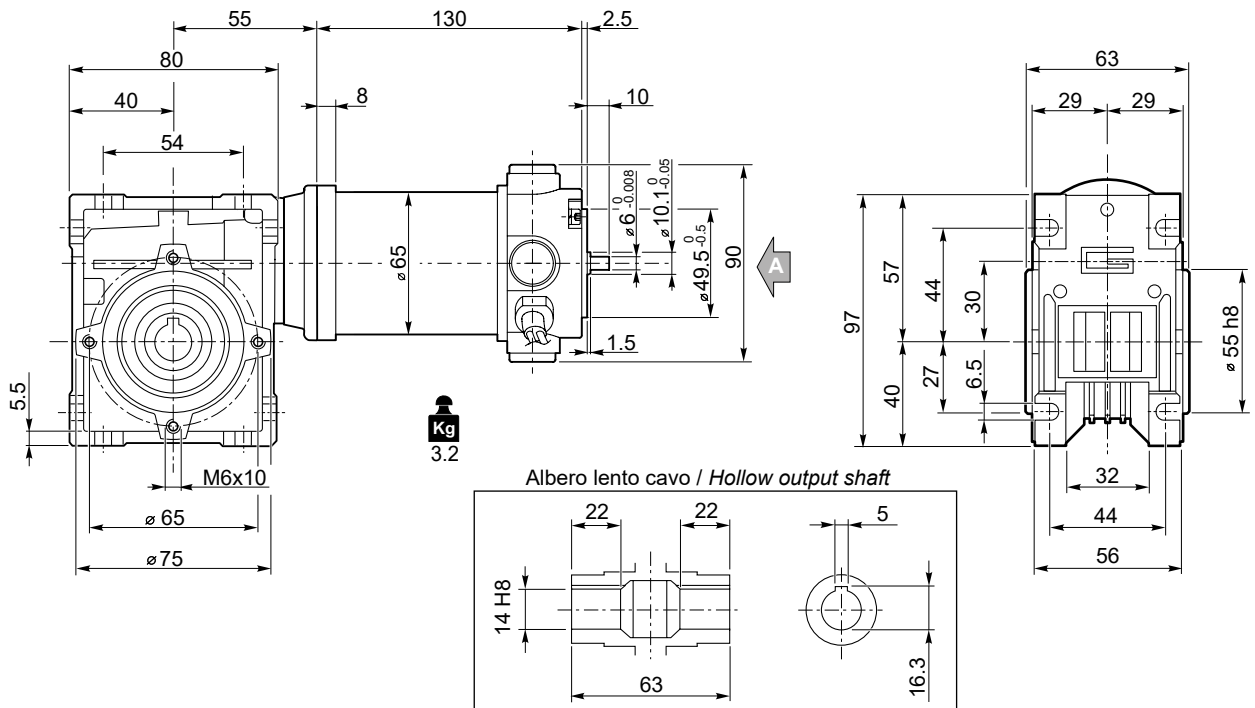

NDCM180/040 U

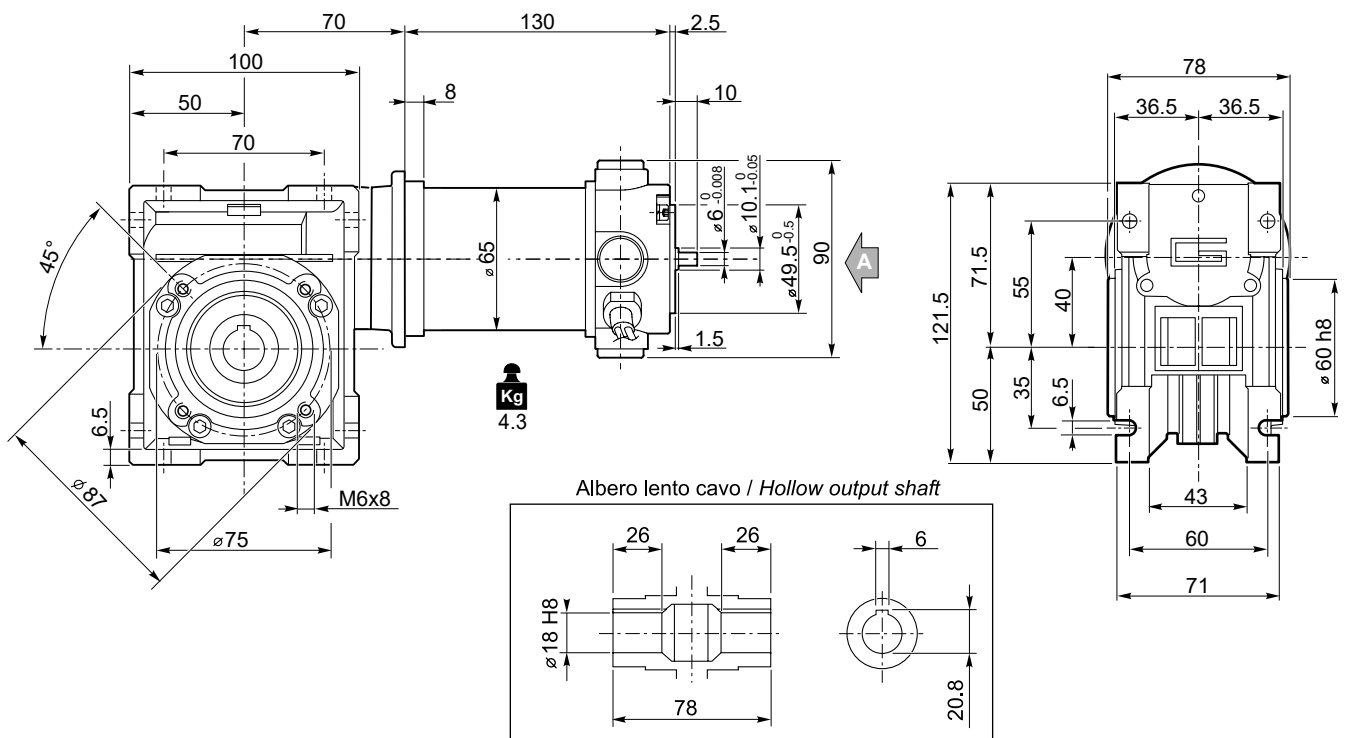

Vista da A
View from A

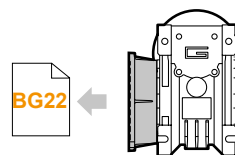
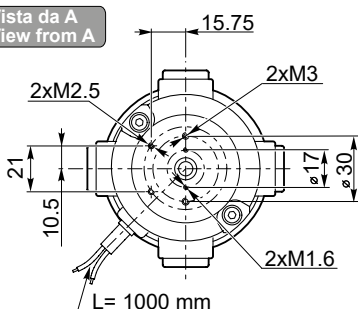

NDCM180/030 F
NDCM180/040 F...

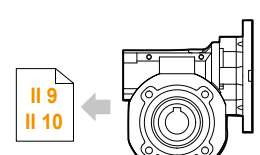

CL030
CL040

Freno / Brake



Encoder



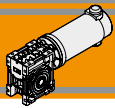

Dimensioni

Dimensions

ECM035/026 U

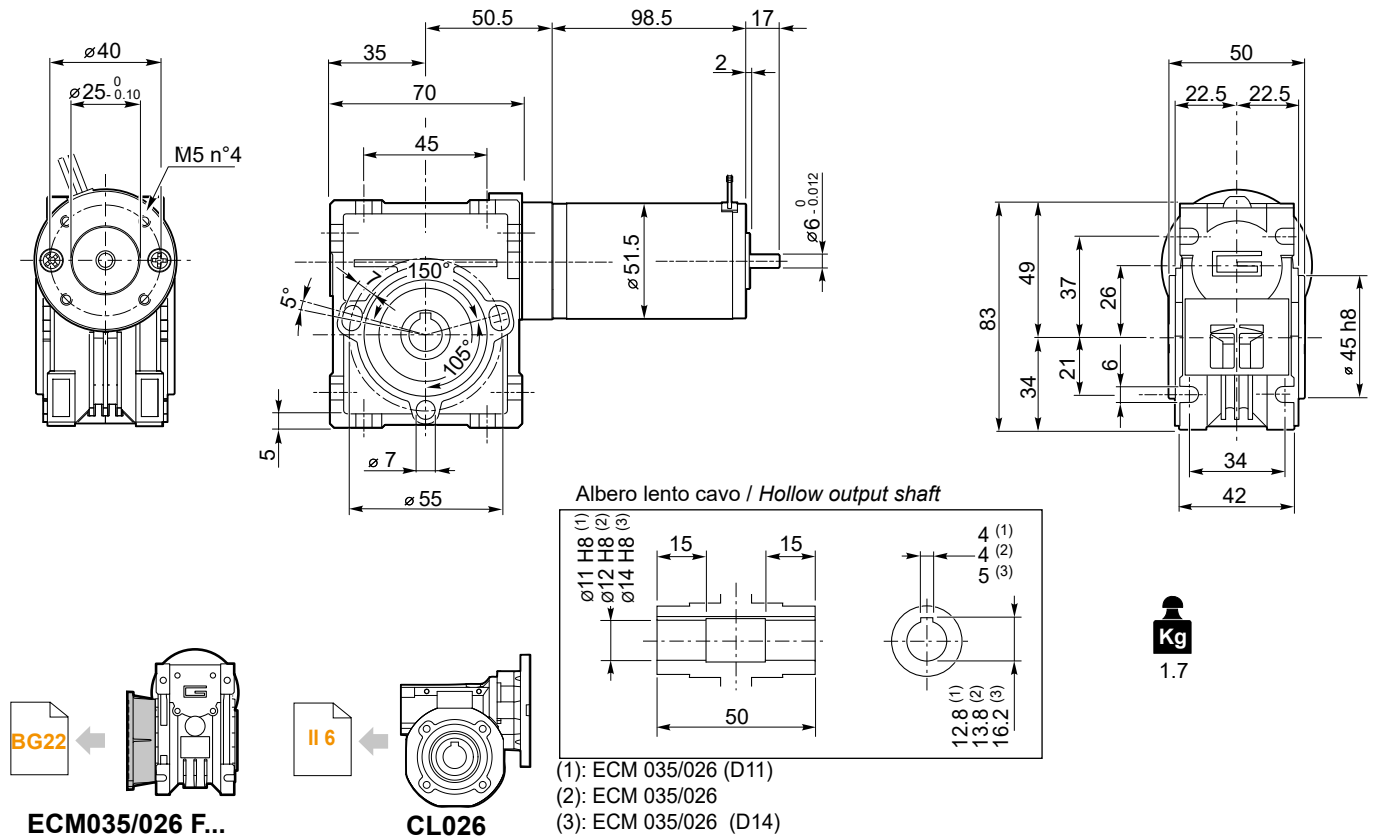

ECM035/030 U

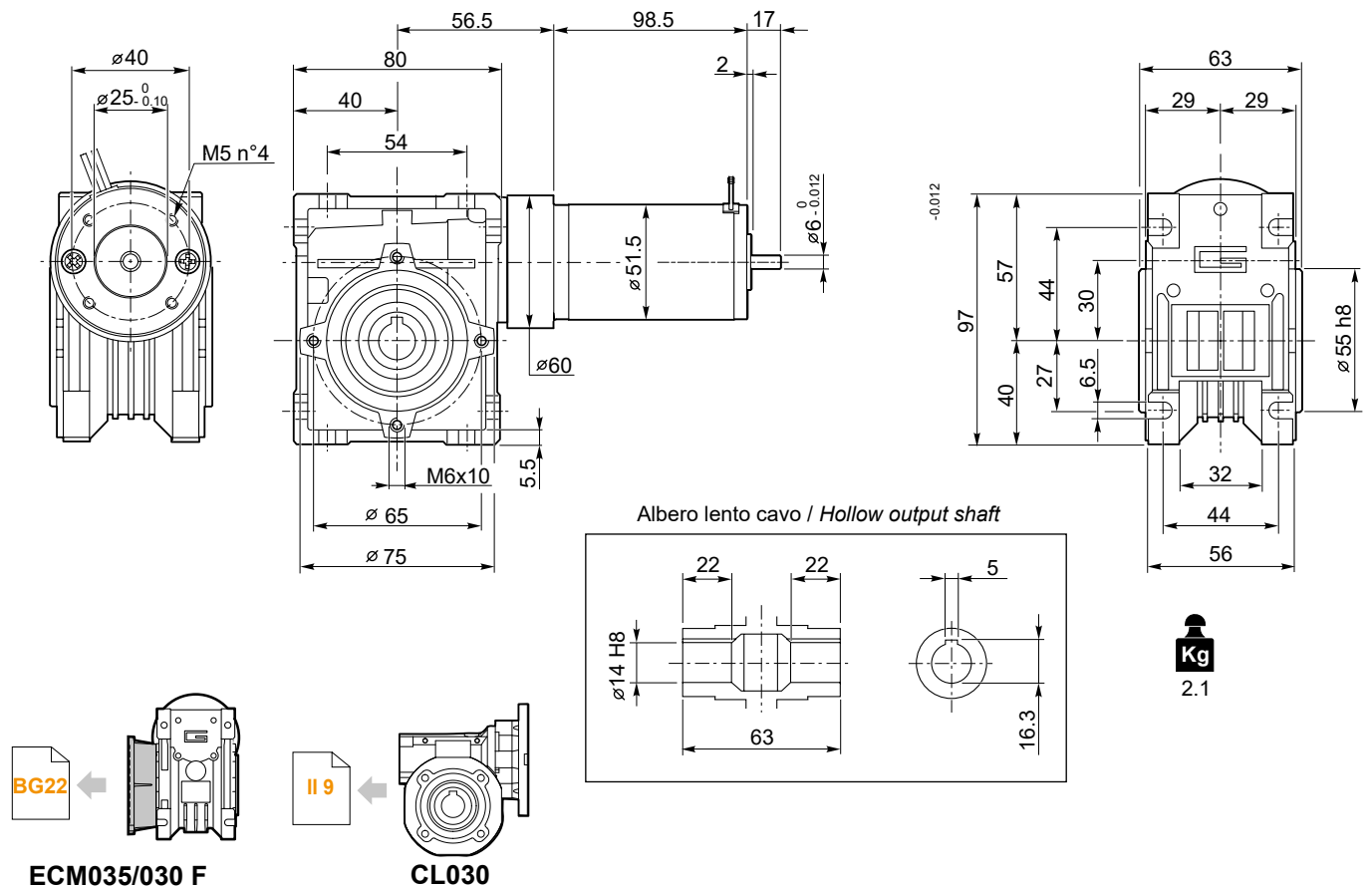

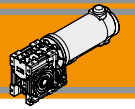

Dimensioni

Dimensions

ECM050/026 U

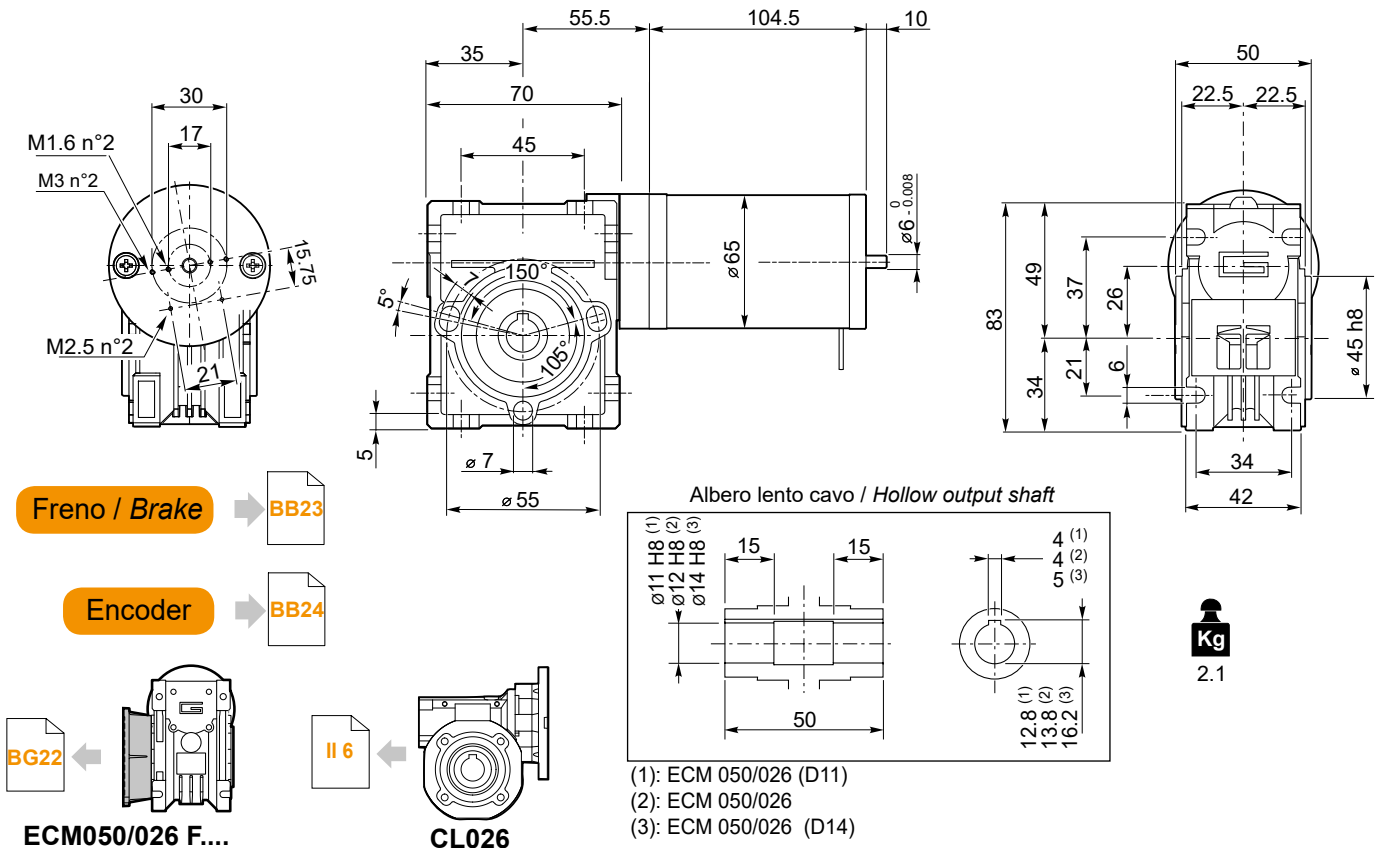

ECM050/030 U

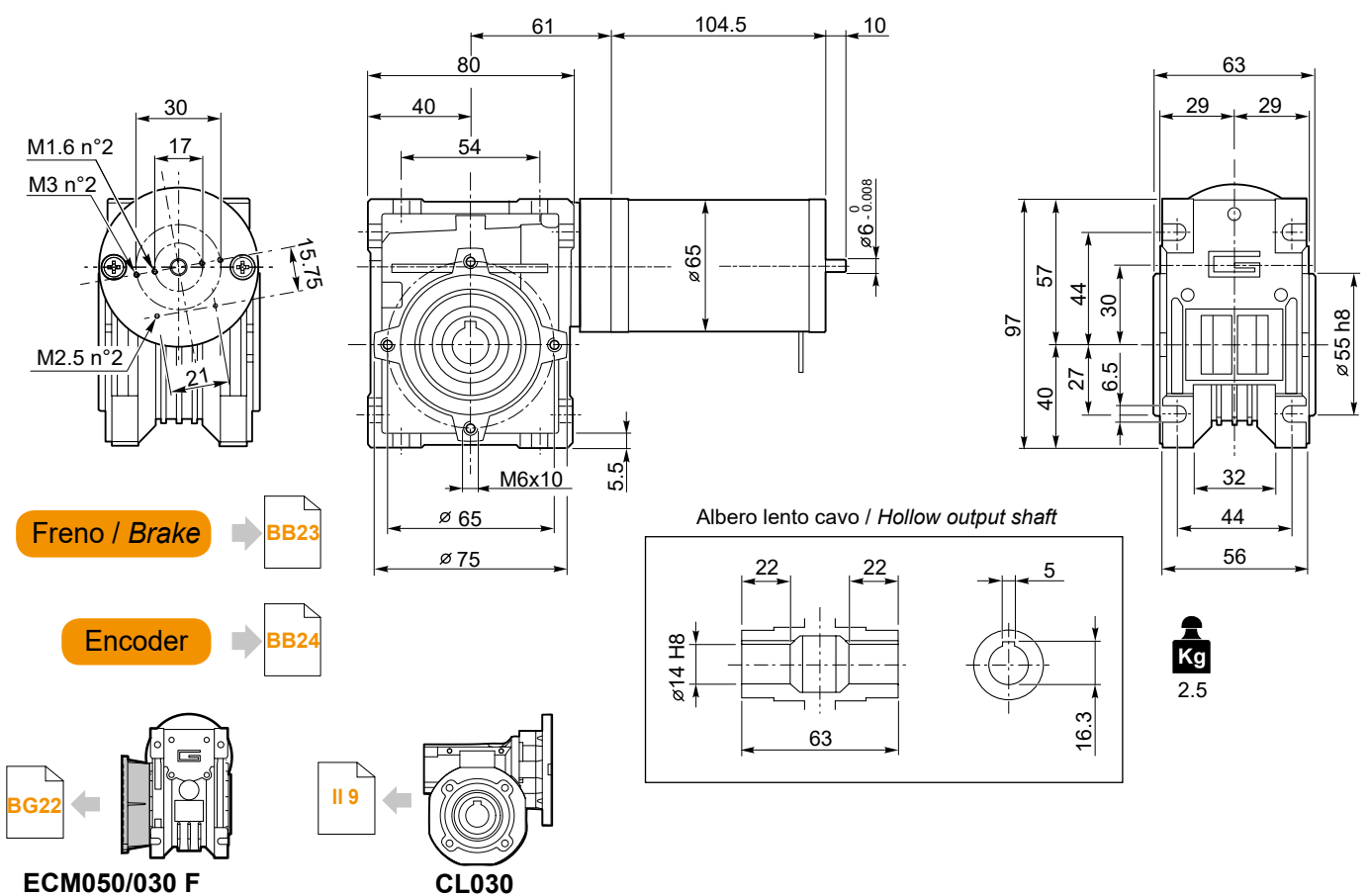

DC

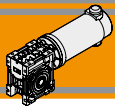

Dimensioni

Dimensions

ECM070/026 U

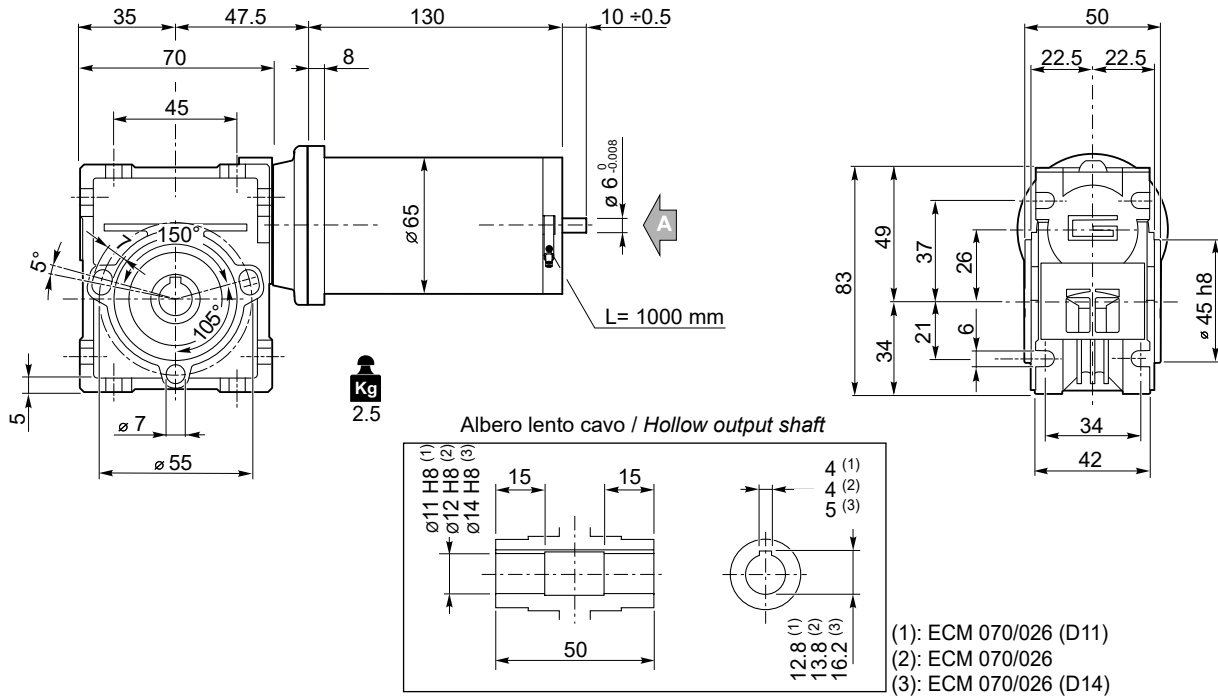

ECM070/030 U

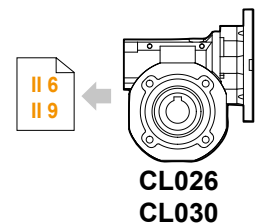
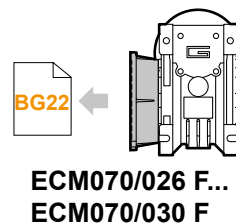
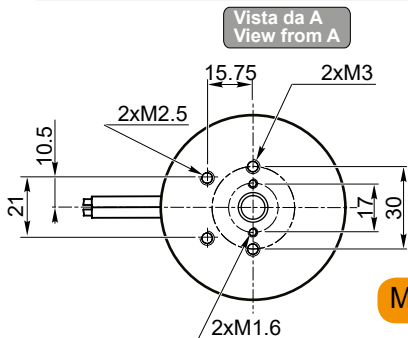
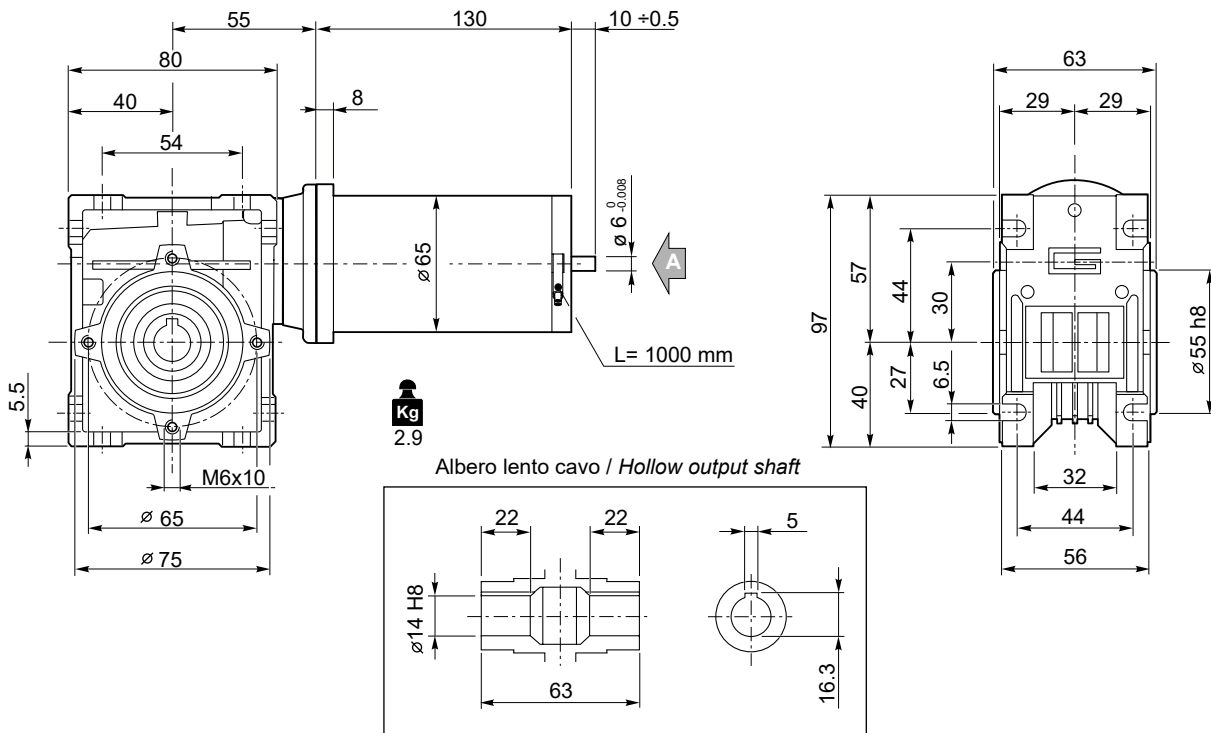

Motori / Motors IP66 → BC2

Freno / Brake → BB23

Encoder → BB24

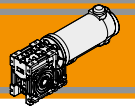

Dimensioni

Dimensions

ECM100/026 U

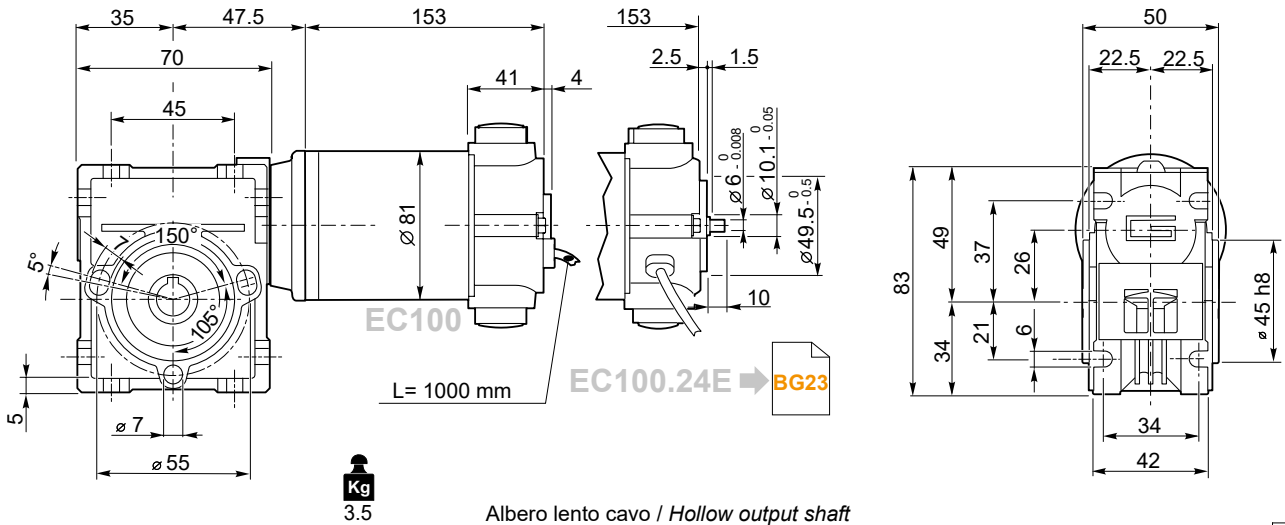

Kg
3.5

Albero lento cavo / Hollow output shaft

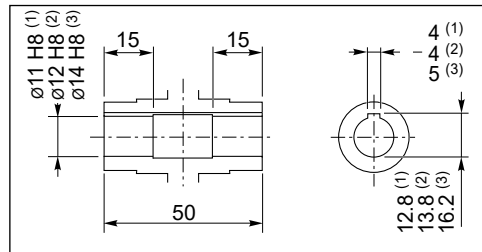

- (1): ECM 100/026 (D11)
- (2): ECM 100/026
- (3): ECM 100/026 (D14)

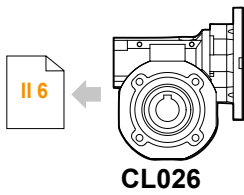
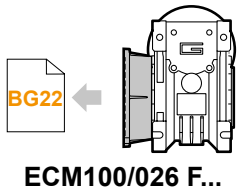

- Motori / Motors IP66** → **BC4**
- Freno / Brake** → **BB23**
- Encoder** → **BB24**

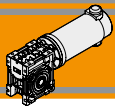

Dimensioni

Dimensions

ECM100/030 U

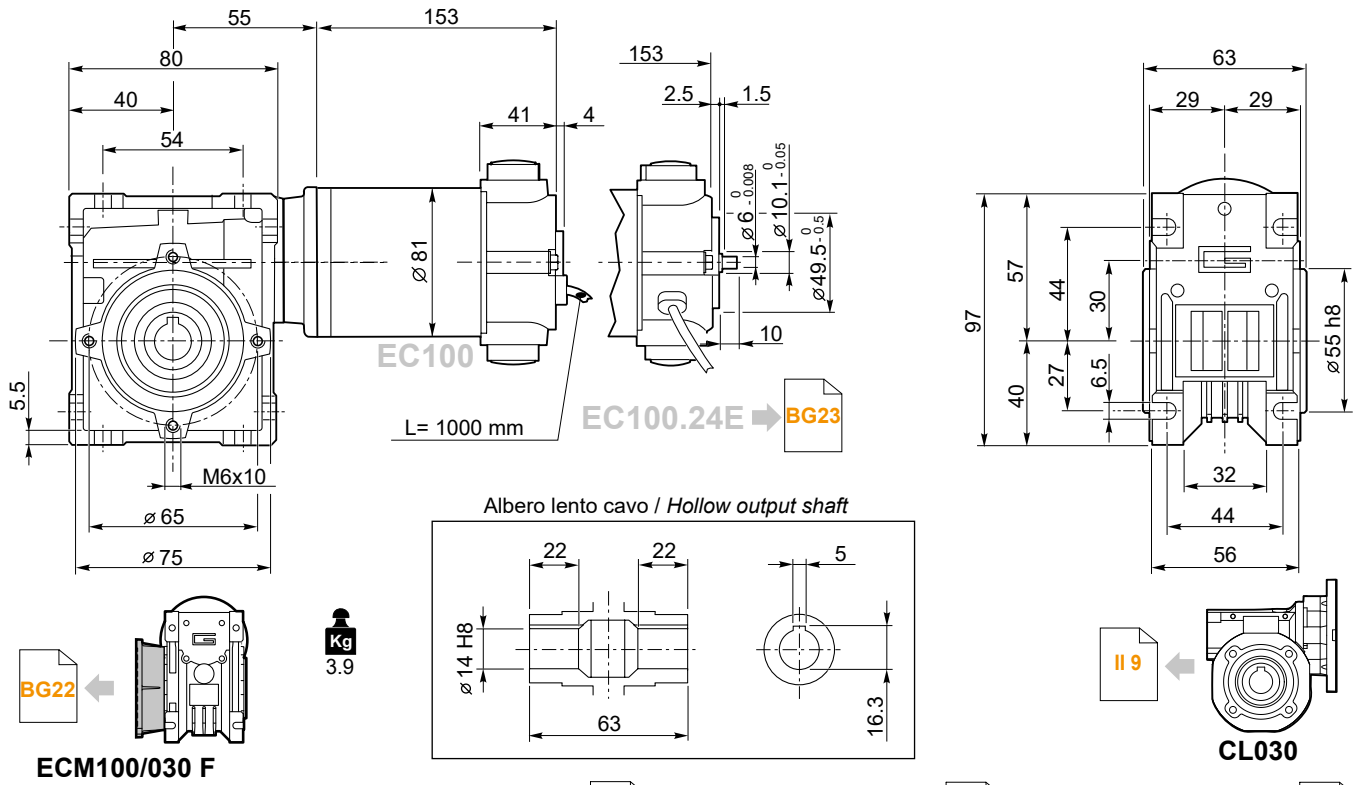

Motori / Motors IP66 → BC4

Freno / Brake → BB23

Encoder → BB24

ECM100/040 U

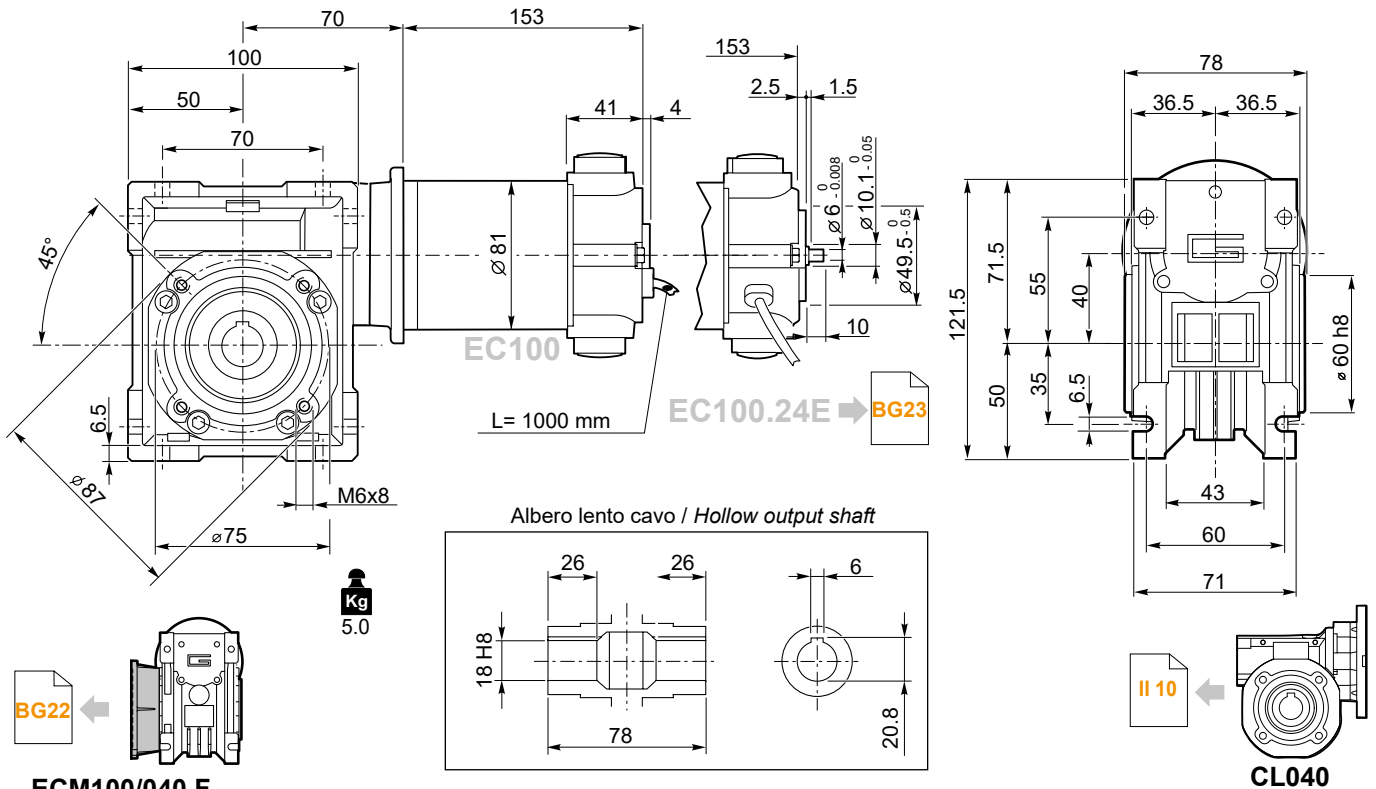

Motori / Motors IP66 → BC4

Freno / Brake → BB23

Encoder → BB24

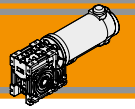

Dimensioni

Dimensions

ECM180/026 U

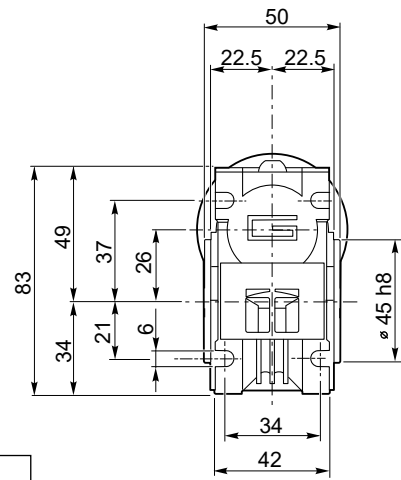
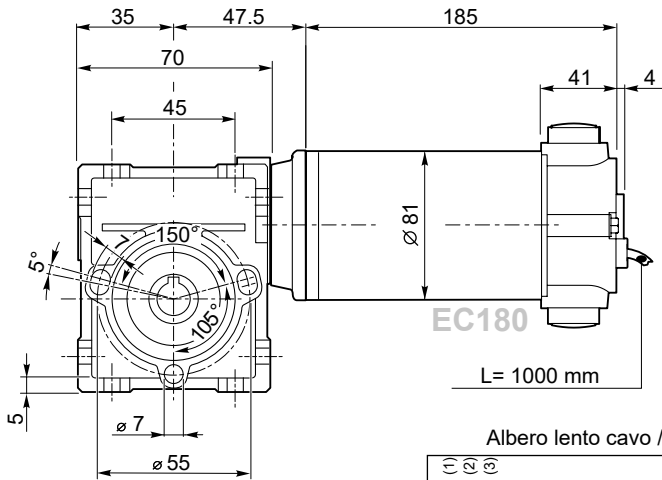

Albero lento cavo / Hollow output shaft

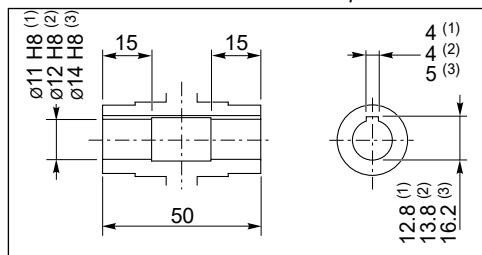

- (1): ECM 180/026 (D11)
- (2): ECM 180/026
- (3): ECM 180/026 (D14)

Kg
4.2

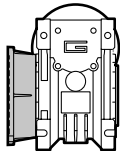

ECM180/026 F...

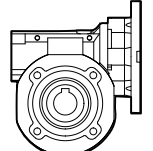

CL026

Motori / Motors IP66

BC6

Freno / Brake

BB23

Encoder

BB24

ECM180/030 U

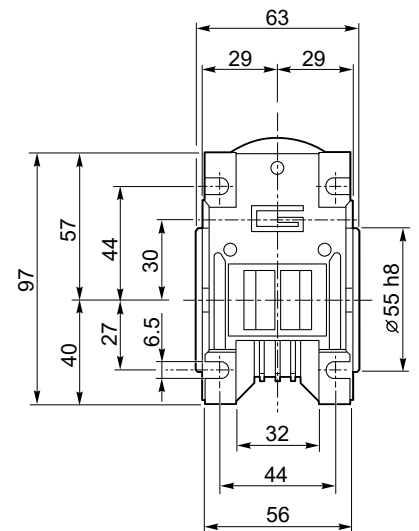
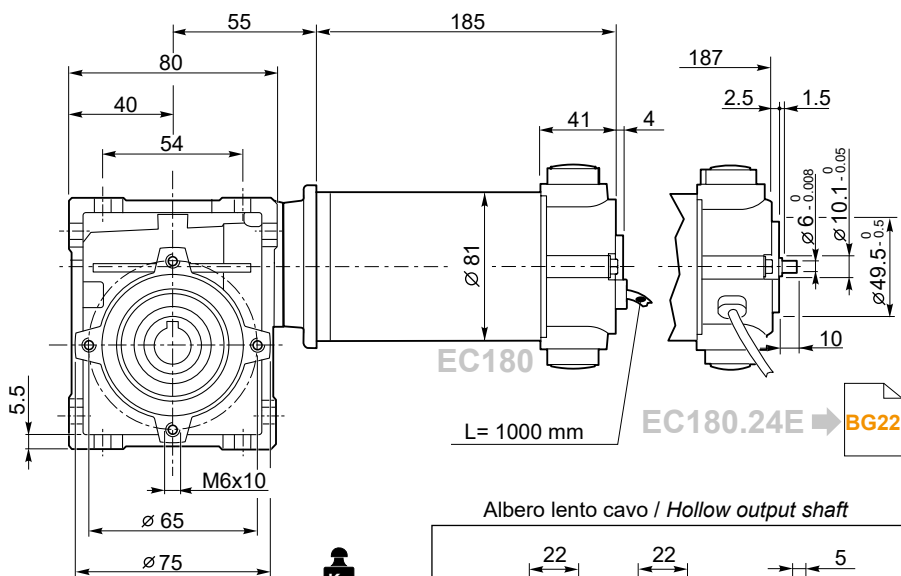

Albero lento cavo / Hollow output shaft

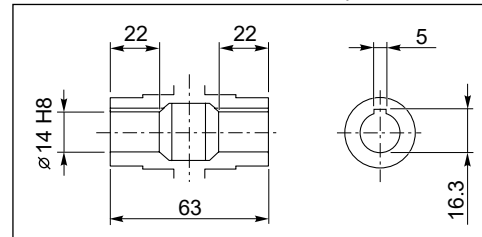

Kg
4.6

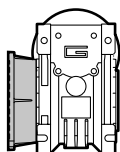

ECM180/030 F

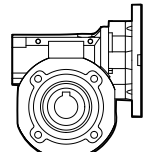

CL030

Motori / Motors IP66

BC6

Freno / Brake

BB23

Encoder

BB24

DC

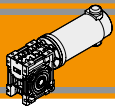

Dimensioni

Dimensions

ECM180/040 U

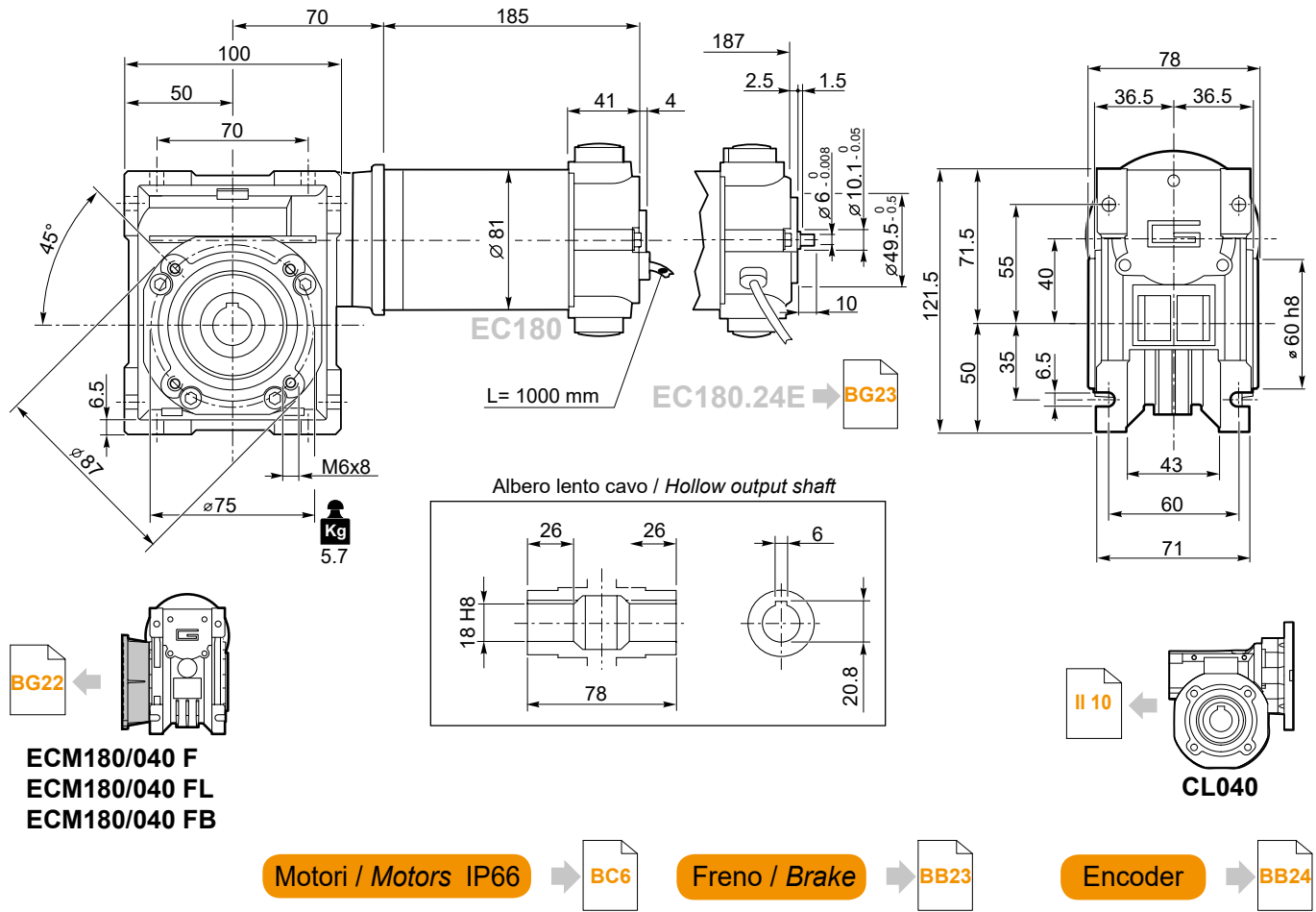

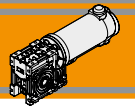

Dimensioni

Dimensions

ECM250/030 U

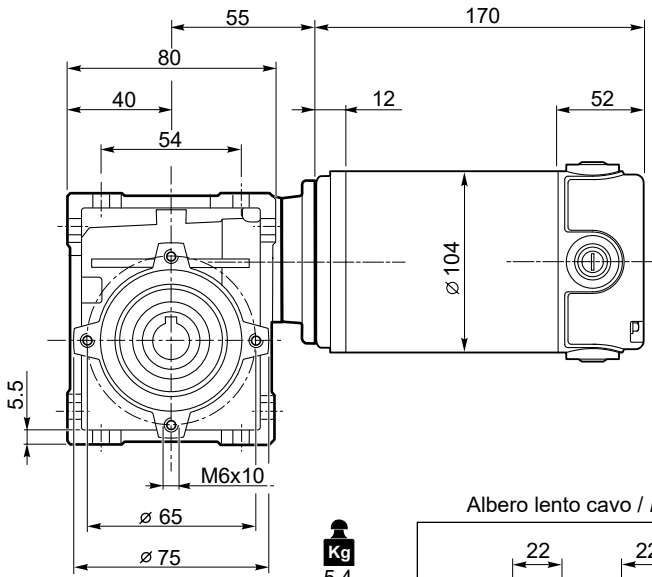

Kg
5.4

Albero lento cavo / Hollow output shaft

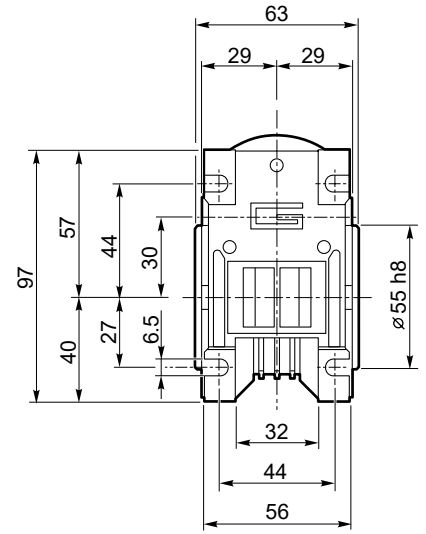
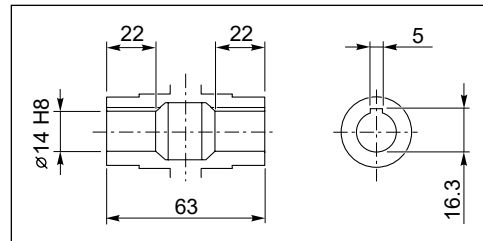

BG22

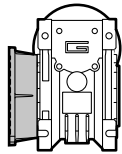

ECM250/030 F

II 9

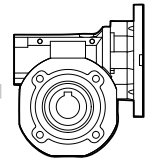

CL030

Motori / Motors IP66

BC8

ECM250/040 U

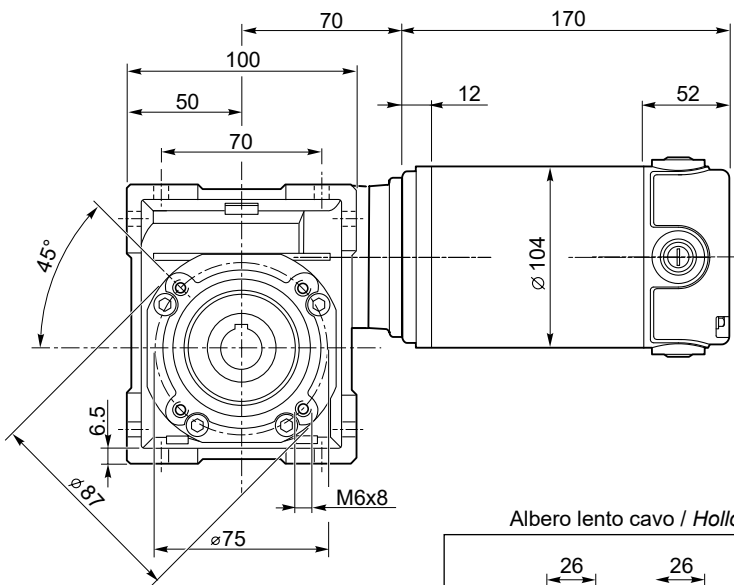

Kg
6.5

Albero lento cavo / Hollow output shaft

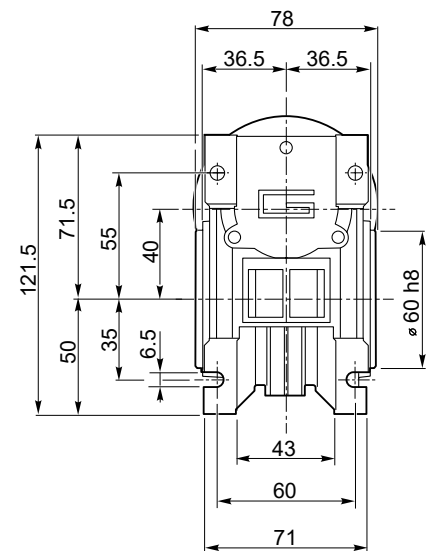
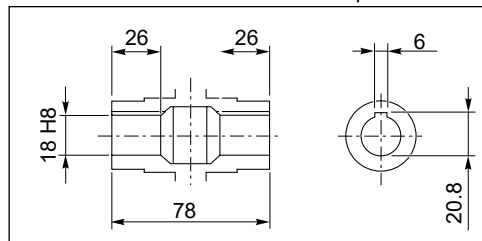

BG22

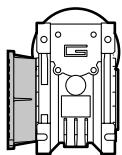

ECM250/040 F
ECM250/040 FL
ECM250/040 FB

II 10

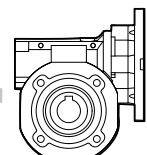

CL040

Motori / Motors IP66

BC8

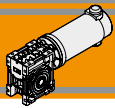

Dimensioni

Dimensions

ECM350/030 U

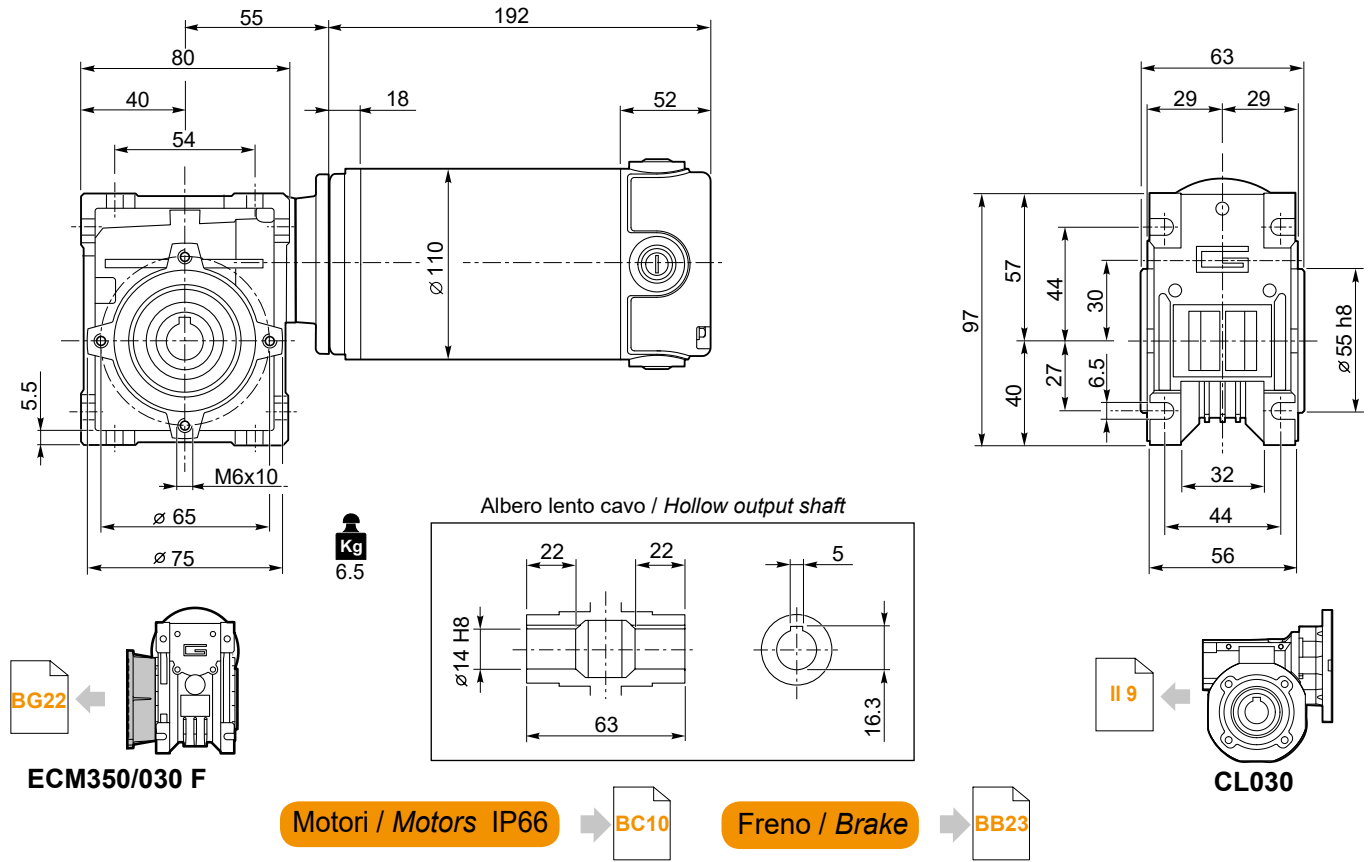

ECM350/040 U

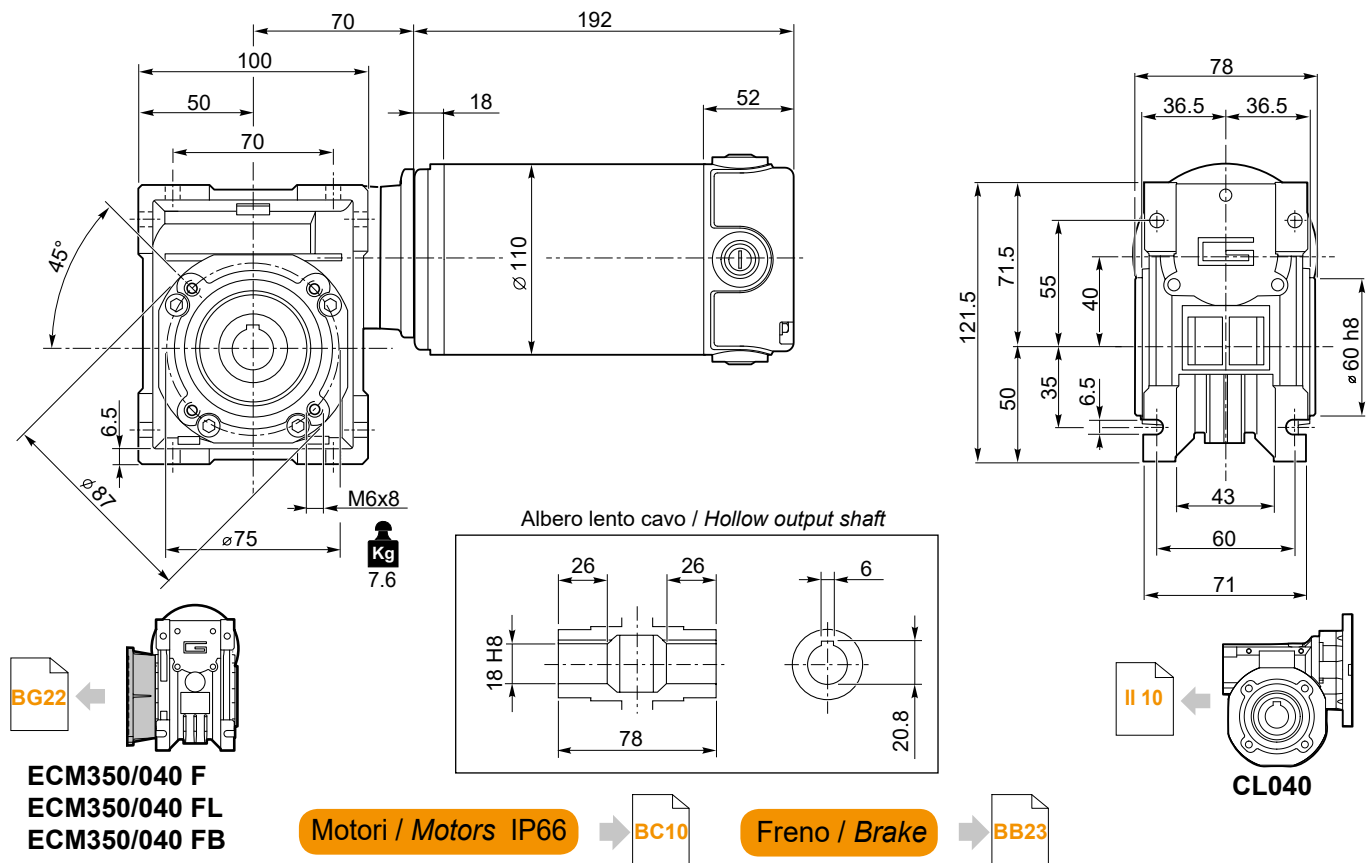

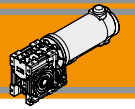

Dimensioni

Dimensions

ECM600/040 U

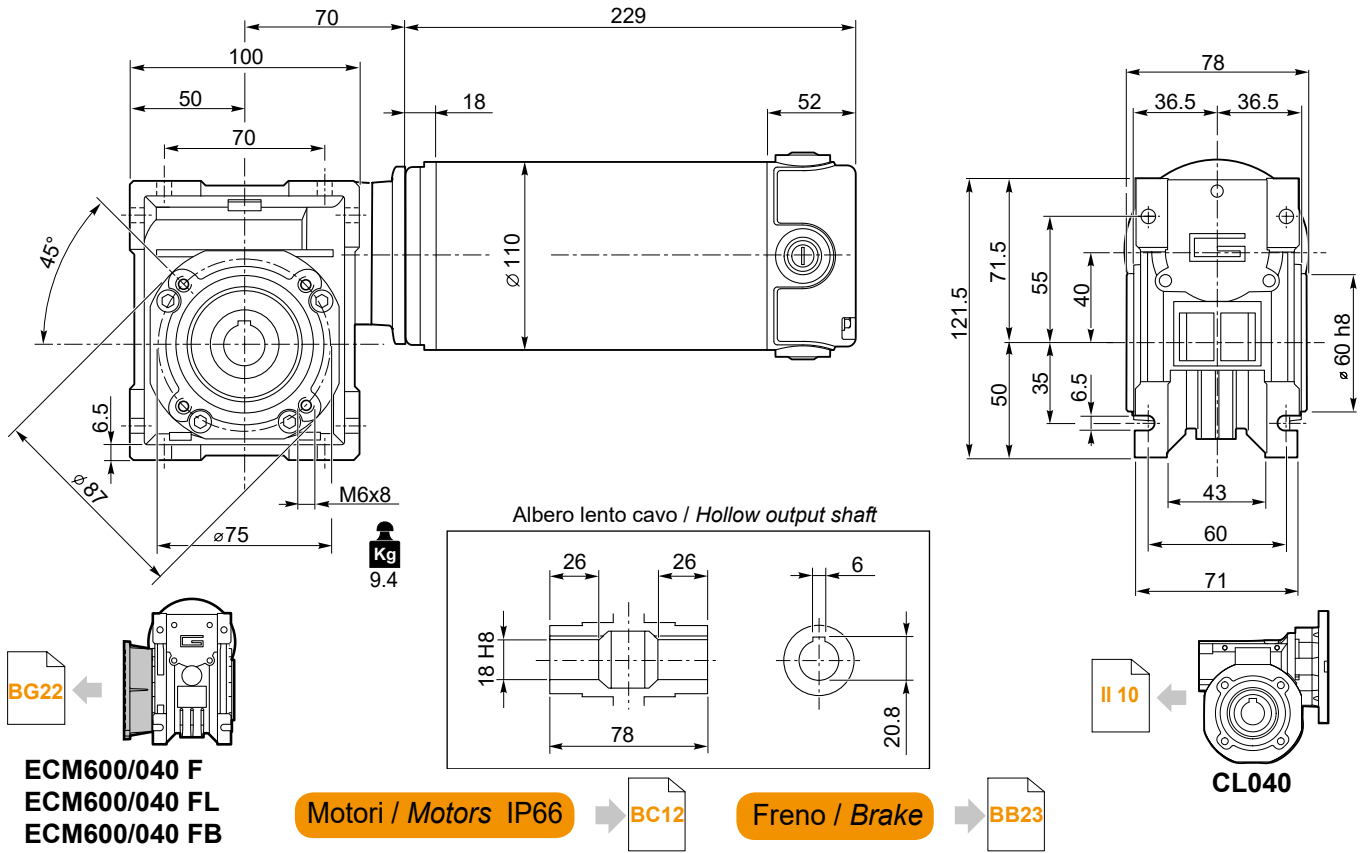

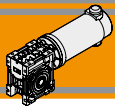

Dimensioni

Dimensions

NDCM.../.... F... - ECM.../... F... Flange uscita / Output flanges

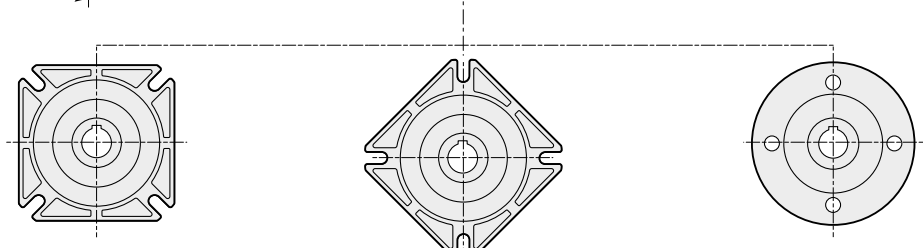
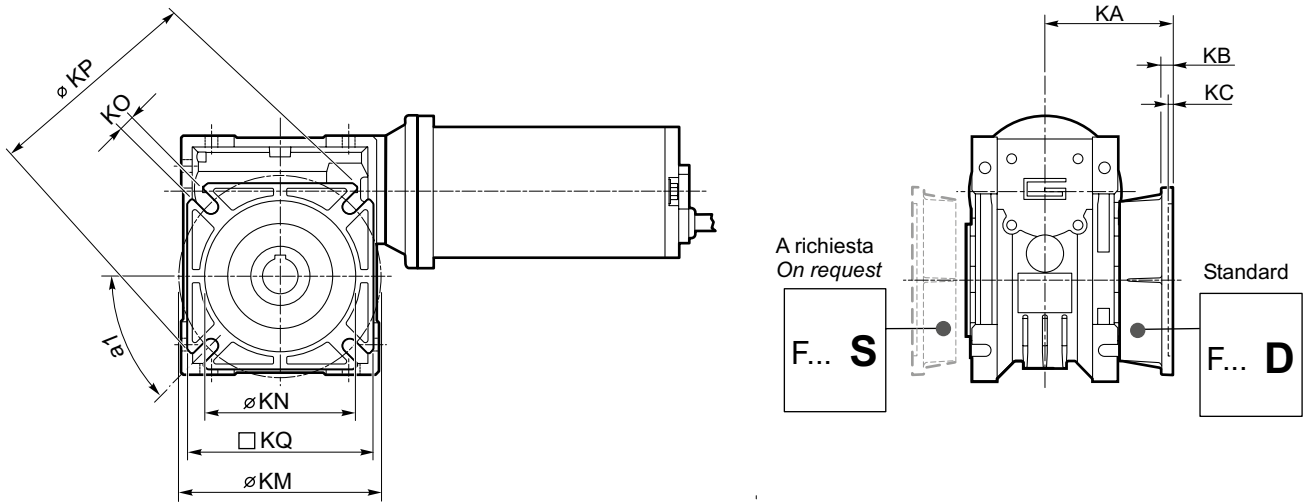

- ..CM026 ../. F**
..CM026 ../. F28
..CM026 ../. F30
..CM026 ../. F30S
..CM030 ../. F..
..CM040 ../. F..
- ..CM026 ../. F30C**
..CM026 ../. F30SC
- ..CM026 ../. F100**

	CM..F							CM..F28							CM..F30							CM..F30S ⁽¹⁾											
	a1	KA	KB	KC	KM	KN _{H8}	KO	KP	KQ	KA	KB	KC	KM	KN _{H8}	KO	KP	KQ	KA	KB	KC	KM	KN _{H8}	KO	KP	KQ	KA	KB	KC	KM	KN _{H8}	KO	KP	KQ
026 (D11)	45°	45	6	4.5	55-69	40	6.5	75	70	44	6.5	5	56-64	40	6.5	70	60	48	6.5	5	68	50	6.5	80	70	50	8.5	7	68	50	6.5	80	70
026 (D14)							(n.4)																										

(1): F30S eseguita con F30 e distanziale di spessore 2 mm / F30S made with F30 and spacer with 2mm thickness

	CM..F30C							CM..F30SC ⁽²⁾							CM..F100										
	a1	KA	KB	KC	KM	KN _{H8}	KO	KP	KQ	KA	KB	KC	KM	KN _{H8}	KO	KP	KQ	KA	KB	KC *	KM	KN _{h7}	KO	KP	KQ
026 (D11)	-	48	6.5	7	68	50	6.5	80	70	50	8.5	7	68	50	6.5	80	70	51.5	8	2 *	86	45	6.5	100	-
026 (D14)																									

(2): F30SC eseguita con F30C e distanziale di spessore 2 mm / F30SC made with F30C and spacer with 2mm thickness

*: Centraggio maschio / Male centering diameter

CM	CM..F							CM..FB							CM..FL										
	a1	KA	KB	KC	KM	KN _{H8}	KO	KP	KQ	KA	KB	KC	KM	KN _{H8}	KO	KP	KQ	KA	KB	KC	KM	KN _{H8}	KO	KP	KQ
030	45°	54.5	6	4	68	50	6.5(n.4)	80	70	—	—	—	—	—	—	—	—	—	—	—	—	—	—	—	—
040	45°	67	7.5	4	80-95	60	9(n.4)	110	95	80	8.5	5	115-125	95	9.5(n.4)	140	112	97	7.5	4.5	80-95	60	9 (n.4)	110	95

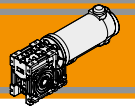

Dimensioni

Dimensions

EC100.24E
EC180.24E

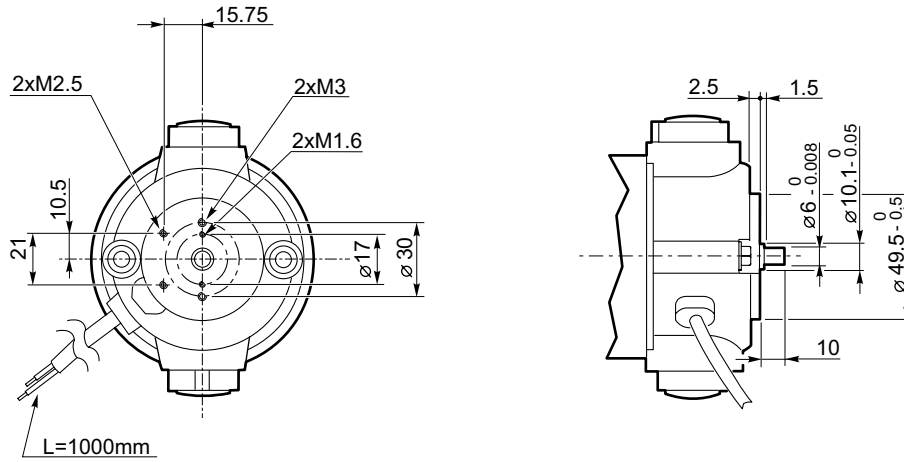

Opzioni

Options

VS - Vite sporgente / Extended input shaft

SC - Safety cover

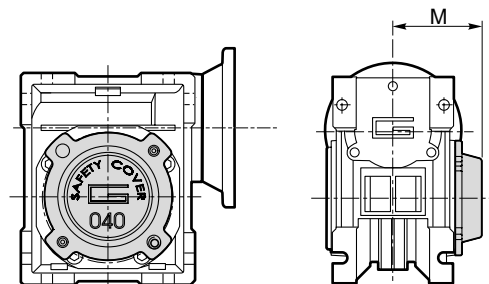
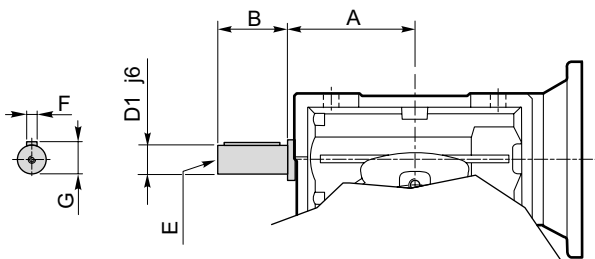

	A	B	D ₁ j6	E	F	G
CM 030	45	20	9	M4	3	10.2
CM 040	53	23	11	M5	4	12.5

	M
CM 030	47
CM 040	54.5

Costruito su richiesta
Built on request

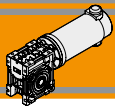

Accessori

Accessories

Albero lento

Output shaft

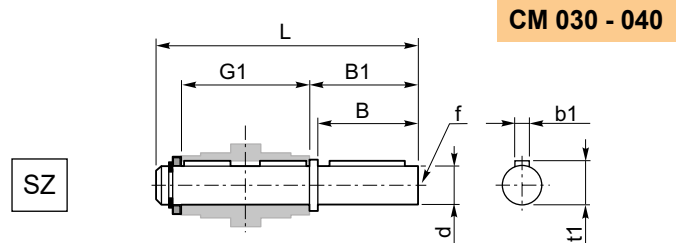
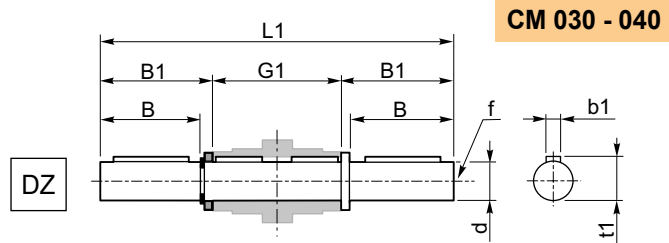

	d h7	B	B1	G1	L	L1	f	b1	t1
CM 030	14	30	32.5	63	102	128	M6	5	16
CM 040	18	40	43	78	128	164	M6	6	20.5

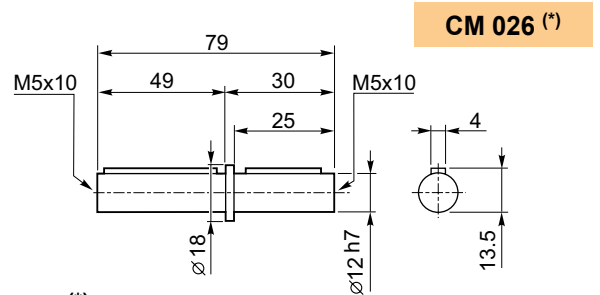

(*)
Nota: disponibile solo per cavo uscita Ø12
Note: available for output hollow shaft Ø12 only

Braccio di reazione

Torque arm

	K1	G	KG	KH	R
CM 030	85	14	23	8	15
CM 040	100	14	31	10	18

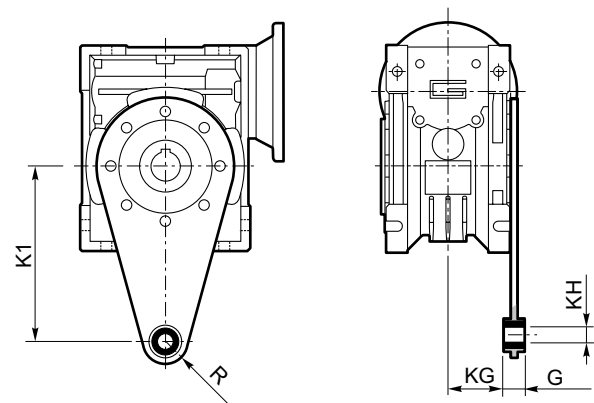

Motoriduttori CC a vite senza fine con precoppia
DC pre stage wormgearmotors

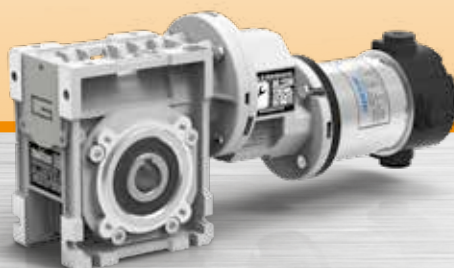

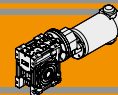

Indice	Index	Pag. Page
Caratteristiche tecniche	<i>Technical features</i>	BH2
Designazione	<i>Classification</i>	BH2
Simbologia	<i>Symbols</i>	BH3
Lubrificazione	<i>Lubrication</i>	BH3
Carichi radiali	<i>Radial loads</i>	BH3
Dati tecnici per servizio S2	<i>Technical data for S2 duty</i>	BH4
Motori applicabili	<i>Motor adapters</i>	BH5
Dimensioni	<i>Dimensions</i>	BH6
Opzioni	<i>Options</i>	BH13
Accessori	<i>Accessories</i>	BH13

Questa sezione annulla e sostituisce ogni precedente edizione o revisione. Qualora questa sezione non Vi sia giunta in distribuzione controllata, l'aggiornamento dei dati ivi contenuto non è assicurato. **In tal caso la versione più aggiornata è disponibile sul nostro sito internet www.transtecno.com**

This section replaces any previous edition and revision. If you obtained this catalogue other than through controlled distribution channels, the most up to date content is not guaranteed. In this case the latest version is available on our web site www.transtecno.com

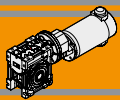

Caratteristiche tecniche

Technical features

I motoriduttori CC a vite senza fine con precoppia a magneti permanenti in neodimio **NDCMP** e in ferrite **ECMP** hanno le seguenti caratteristiche principali:

NDCMP neodymium permanent magnets and **ECMP** ferrite permanent magnets DC pre stage wormgearmotors range has the following main features:

- Alimentazione in bassa tensione 12/24 Vcc
- Possibilità di montaggio encoder e freno
- Potenze motore disponibili da 100 a 350W S2
- Carcasse dei riduttori in pressofusione di alluminio
- Lubrificazione permanente con olio sintetico

- Low voltage power supply 12/24 Vdc
- Suitable for encoder and brake assembly
- Motor power ratings available from 100 up to 350W S2
- Die-cast aluminum housings
- Permanent synthetic oil long-life lubrication.

Designazione

Classification

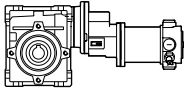
MOTORIDUTTORE / GEARMOTOR										
NDCMP	120/056/030		U	90	SZDX	BRSX	90	P4	240	VS
Tipo Type	Grandezza Size		Versione Riduttore Gearbox Version	Rapporto Ratio	Albero di uscita Output shaft	Braccio di reazione Torque arm	Angolo Angle	Pos. di montaggio precoppia Pre stage mounting position	Versione Motore Motor Version	Opzioni Options
 <p>NDCMP</p>	120/056/030	180/056/030	U FD FS FLD FLS FBD FBS	Vedere tabella <i>See tables</i>	SZDX SZSX DZ	BRDX BRSX *	0° 90° 180° 270°	P1 P2 P3 (standard) P4	120 — 240	VS
	120/056/040	180/056/040								

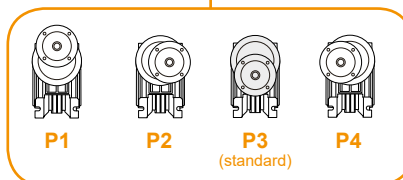

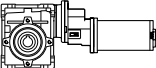
MOTORIDUTTORE / GEARMOTOR										
ECMP	070/056/030		U	90	SZDX	BRSX	90	P4	240	VS
Tipo Type	Grandezza Size		Versione Riduttore Gearbox Version	Rapporto Ratio	Albero di uscita Output shaft	Braccio di reazione Torque arm	Angolo Angle	Pos. di montaggio precoppia Pre stage mounting position	Versione Motore Motor Version	Opzioni Options
 <p>ECMP</p>	070/056/030	180/056/030	U FD FS FLD FLS FBD FBS	Vedere tabella <i>See tables</i>	SZDX SZSX DZ	BRDX BRSX *	0° 90° 180° 270°	P1 P2 P3 (standard) P4	120 240 24E	VS
	070/056/040	180/056/040								
	100/056/030	250/063/040								
	100/056/040									

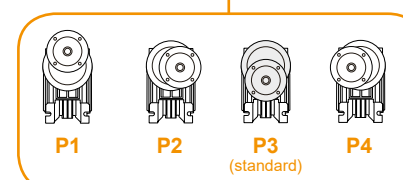

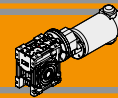

Designazione

Classification

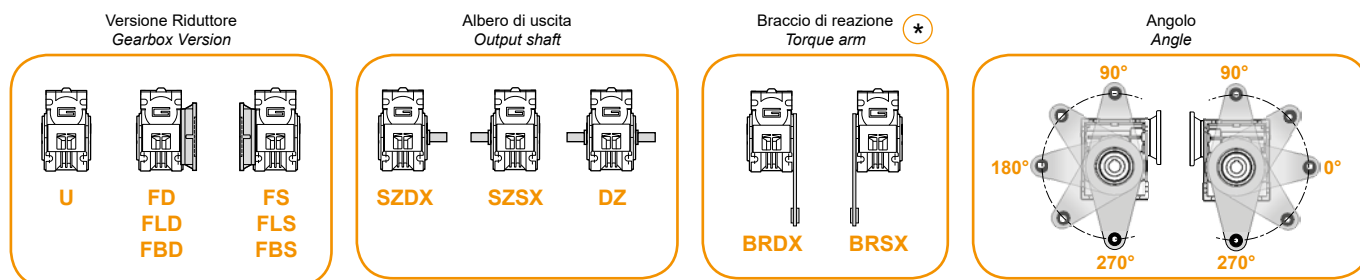

* NOTA: il braccio di reazione viene fornito smontato.
NOTE: the torque arm will be supplied not assembled.

Simbologia

Symbols

n_1 [min^{-1}] Velocità in ingresso / Input speed
 n_2 [min^{-1}] Velocità in uscita / Output speed
i Rapporto di riduzione / Ratio
 P_1 [kW] Potenza in entrata / Input power

M_2 [Nm] Coppia in uscita in funzione di P_1 / Output torque referred to P_1
sf Fattore di servizio / Service factor
 R_2 [N] Carico radiale ammissibile in uscita / Permitted output radial load
 A_2 [N] Carico assiale ammissibile in uscita / Permitted output axial load

Lubrificazione

Lubrication

I riduttori a vite senza fine con precoppia della serie CMP sono lubrificati a vita con olio sintetico di viscosità 320 e possono essere installati in qualunque posizione di montaggio.

Permanent synthetic oil long - life lubrication allow to use CMP range in all mounting positions.

Carichi radiali

Radial loads

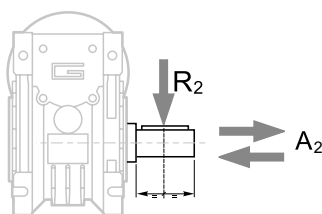

n_2 [min^{-1}]	R_2 [N]	
	CM030	CM040
35	1179	2210
28	1270	2381
23	1356	2542
18	1471	2759
14	1600	3000

Quando il carico radiale risultante non è applicato sulla mezzeria dell'albero occorre calcolare quello effettivo con la seguente formula:

When the resulting radial load is not applied on the centre line of the shaft it is necessary to calculate the effective load with the following formula:

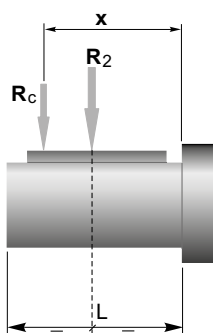

$$R_c = \frac{R_2 \cdot a}{(b+x)} \leq R_{2MAX}$$

$$R \leq R_c$$

a, b = valori riportati nella tabella
a, b = values given in the table

	CM	
	030	040
<i>a</i>	65	84
<i>b</i>	50	64
R_{2MAX}	1600	3000

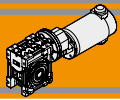

Dati tecnici per servizio S2

NDCMP

Technical data for S2 duty

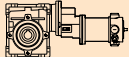
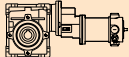
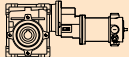
P_1 [W]	n_2 [min ⁻¹]	M_2 [Nm]	sf	i		Versione motore Motor version
160						
(3000 min ⁻¹)	50	21	1.0	60		120/056/030
	40	25	0.9	75		
	33	28	1.0	90		
	25	35	0.7	120		
	20	31	0.7	150		
	50	22	2.0	60		120/056/040
	40	26	1.7	75		
	33	30	1.9	90		
	25	36	1.3	120		
	20	43	1.1	150		
	17	48	0.9	180		
	13	55	0.7	240		
	10	51	0.7	300		

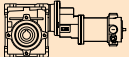
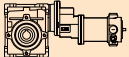
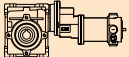
P_1 [W]	n_2 [min ⁻¹]	M_2 [Nm]	sf	i		Versione motore Motor version
250						
(3000 min ⁻¹)	50	31	0.7	60		180/056/030
	40	31	0.7	75		
	33	39	0.7	90		
	25	33	0.7	120		
	20	31	0.7	150		
	50	35	1.3	60		180/056/040
	40	41	1.1	75		
	33	46	1.2	90		
	25	56	0.9	120		
	20	66	0.7	150		
	17	61	0.7	180		
	13	57	0.7	240		
	10	51	0.7	300		



Dati tecnici per servizio S2

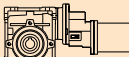
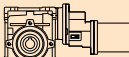
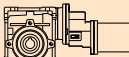

ECMP

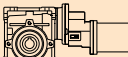
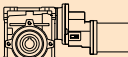
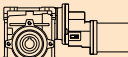
Technical data for S2 duty

P_1 [W]	n_2 [min ⁻¹]	M_2 [Nm]	sf	i		Versione motore Motor version
100						
(3000 min ⁻¹)	50	13	1.7	60		ECMP070/056/030
	40	16	1.4	75		
	33	17	1.6	90		
	25	22	1.1	120		
	20	25	0.9	150		
	50	14	3.2	60		ECMP070/056/040
	40	16	2.7	75		
	33	19	3.0	90		
	25	22	2.1	120		
	20	27	1.7	150		
	17	30	1.4	180		
	13	34	1.2	240		
	10	38	0.9	300		

P_1 [W]	n_2 [min ⁻¹]	M_2 [Nm]	sf	i		Versione motore Motor version
250						
(3000 min ⁻¹)	50	33	0.7	60		ECMP180/056/030
	40	31	0.7	75		
	33	39	0.7	90		
	25	33	0.7	120		
	20	31	0.7	150		
	50	35	1.3	60		ECMP180/056/040
	40	41	1.1	75		
	33	46	1.2	90		
	25	56	0.9	120		
	20	67	0.7	150		
	17	61	0.7	180		
	13	57	0.7	240		
	10	51	0.7	300		
	50	35	1.3	60		
	40	41	1.1	75		
	33	46	1.2	90		
	25	56	0.9	120		

P_1 [W]	n_2 [min ⁻¹]	M_2 [Nm]	sf	i		Versione motore Motor version
140						
(3000 min ⁻¹)	50	19	1.2	60		ECMP100/056/030
	40	22	1.0	75		
	33	24	1.1	90		
	25	30	0.8	120		
	20	31	0.7	150		
	50	19	2.3	60		ECMP100/056/040
	40	23	1.9	75		
	33	26	2.2	90		
	25	31	1.5	120		
	20	37	1.2	150		
	17	42	1.0	180		
	13	48	0.8	240		
	10	54	0.7	300		

P_1 [W]	n_2 [min ⁻¹]	M_2 [Nm]	sf	i		Versione motore Motor version
350						
(3000 min ⁻¹)	50	48	0.9	60		ECMP250/063/040
	40	57	0.8	75		
	33	65	0.9	90		
	25	69	0.7	120		

NOTA
Verificare sempre che la coppia M2 utilizzata non
ecceda il valore indicato nelle caselle in grigio
NOTE
Please check that the output torque M2 does not
exceed the value in the grey areas

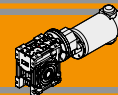

Motori applicabili

Motor adapters

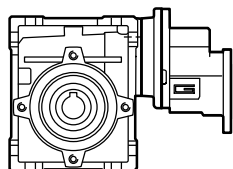
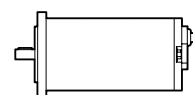
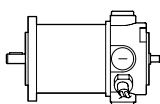

		ND		EC					
		120.120 120.240	180.120 180.240	070.12E 070.24E	100.120 100.240 100.24E	180.120 180.240	180.24E	250.120 250.240	350.120 350.240
CMP	056/030	150	150	150	150	150			
	056/040	300	300	300	300	300			
	063/040						120	120	120

150 Rapporto di riduzione massimo i_{max}
Maximum ratio i_{max}

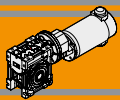

Dimensioni

Dimensions

NDCMP120/056/030 U

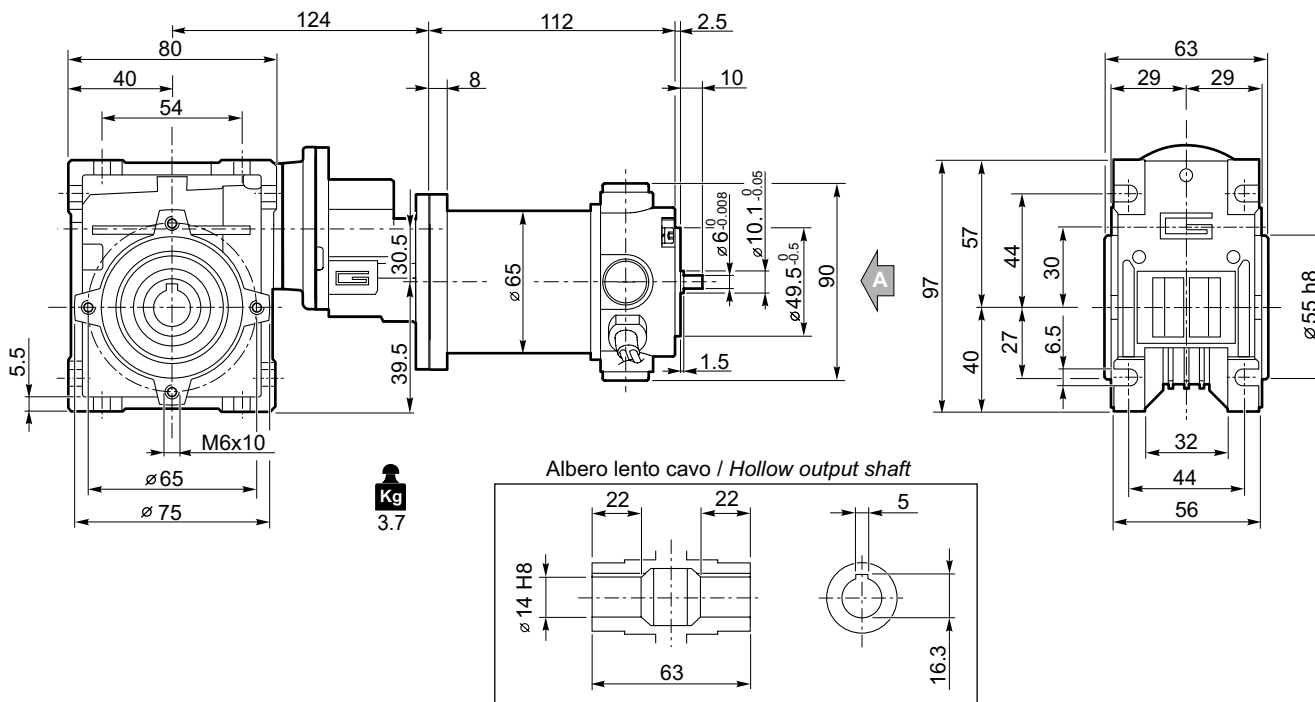

NDCMP120/056/040 U

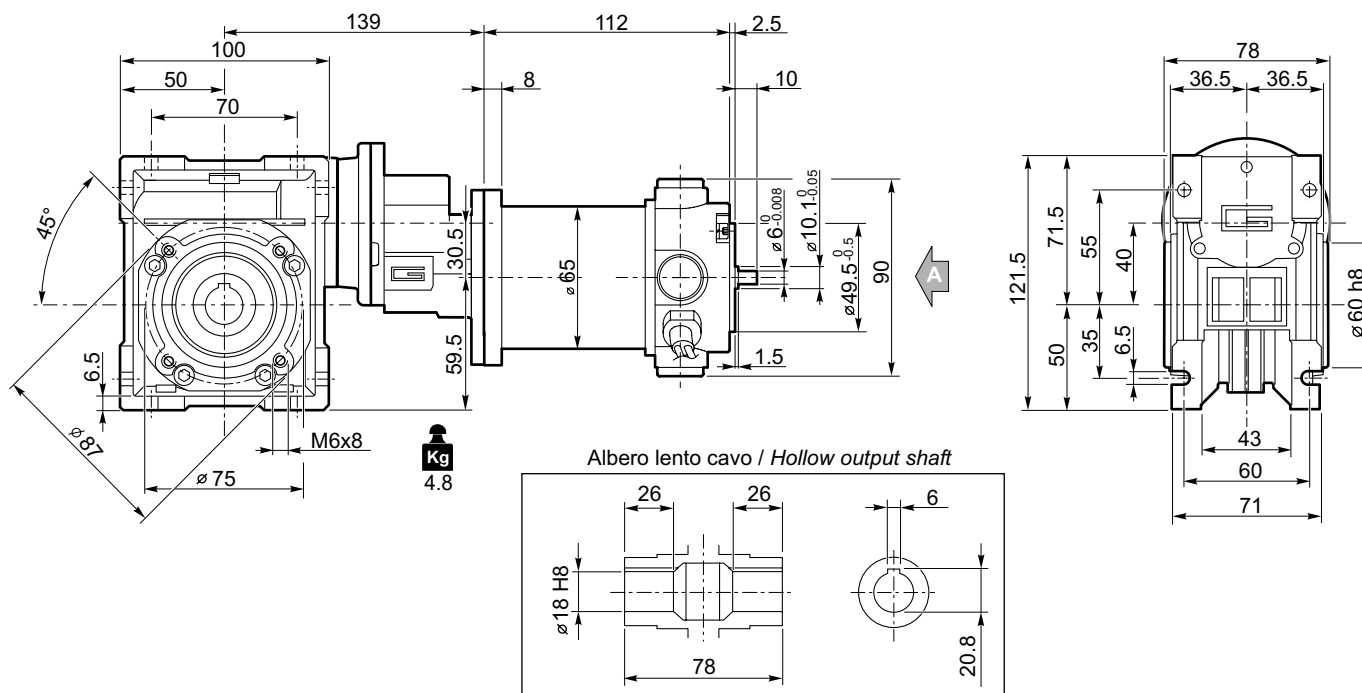

Vista da A
View from A

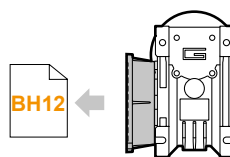
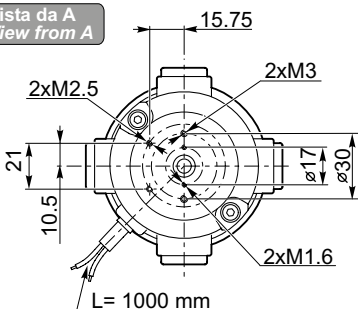

NDCMP120/056/030 F
NDCMP120/056/040 F...

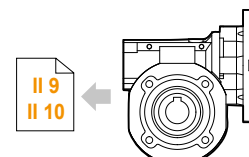

CL030
CL040

Freno / Brake

BA9

Encoder

BA9

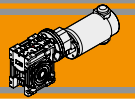

Dimensioni

Dimensions

NDCMP180/056/030 U

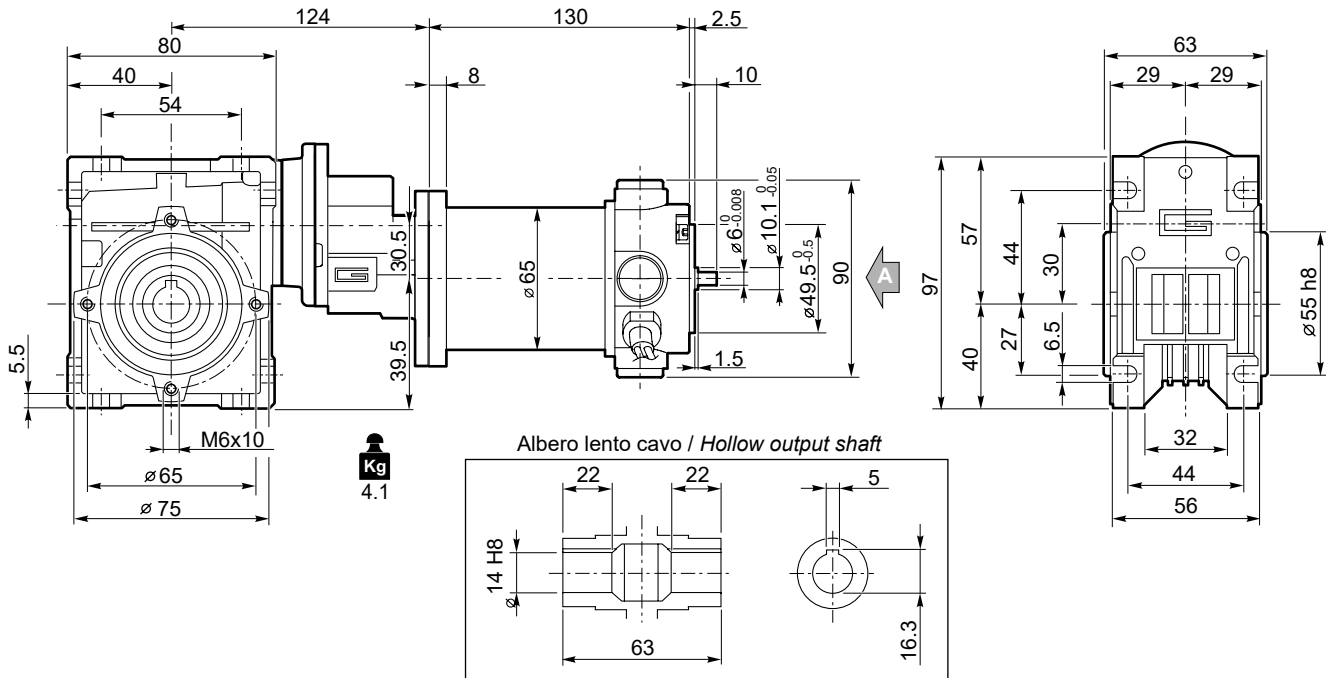

NDCMP180/056/040 U

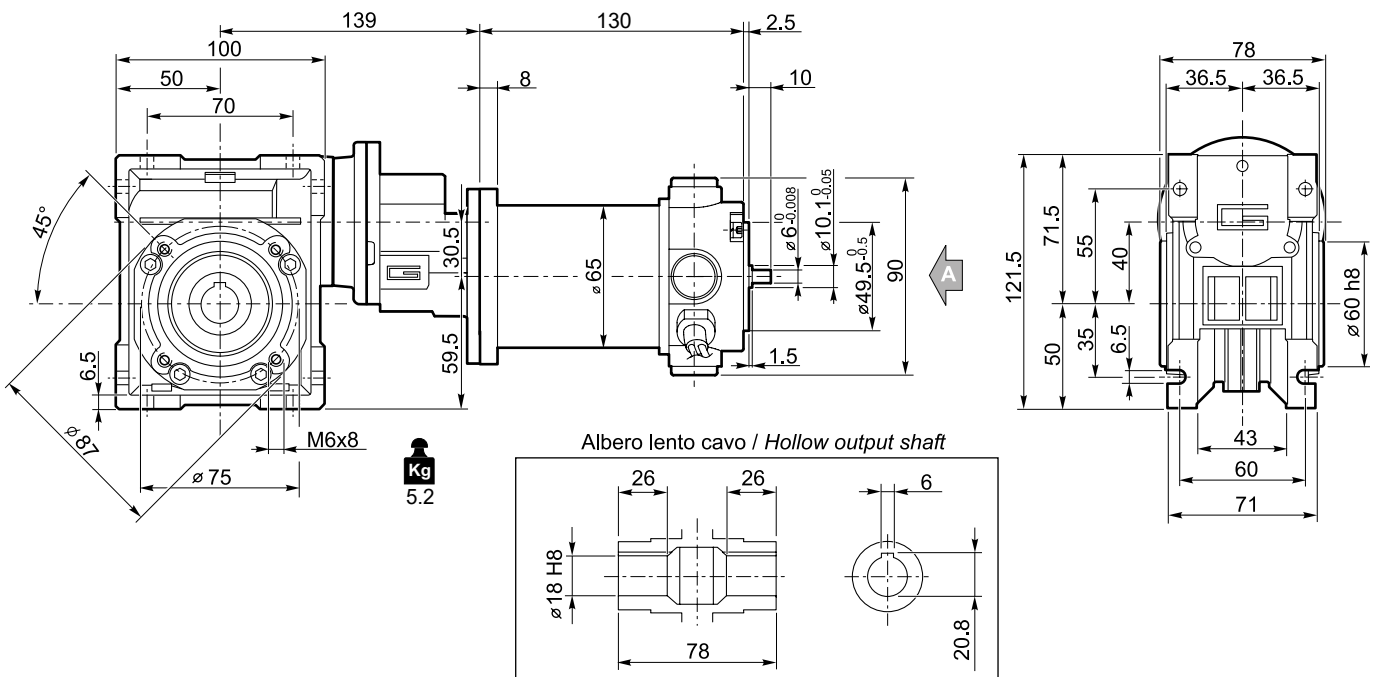

Vista da A
View from A

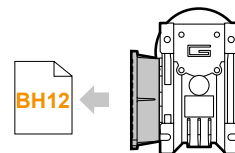
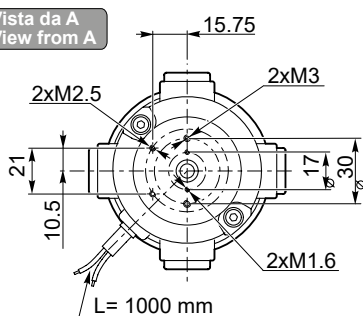

NDCMP180/056/030 F
NDCMP180/056/040 F..

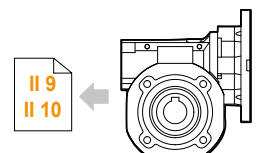

CL030
CL040

Freno / Brake



Encoder



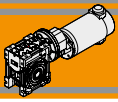

Dimensioni

Dimensions

ECMP070/056/030 U

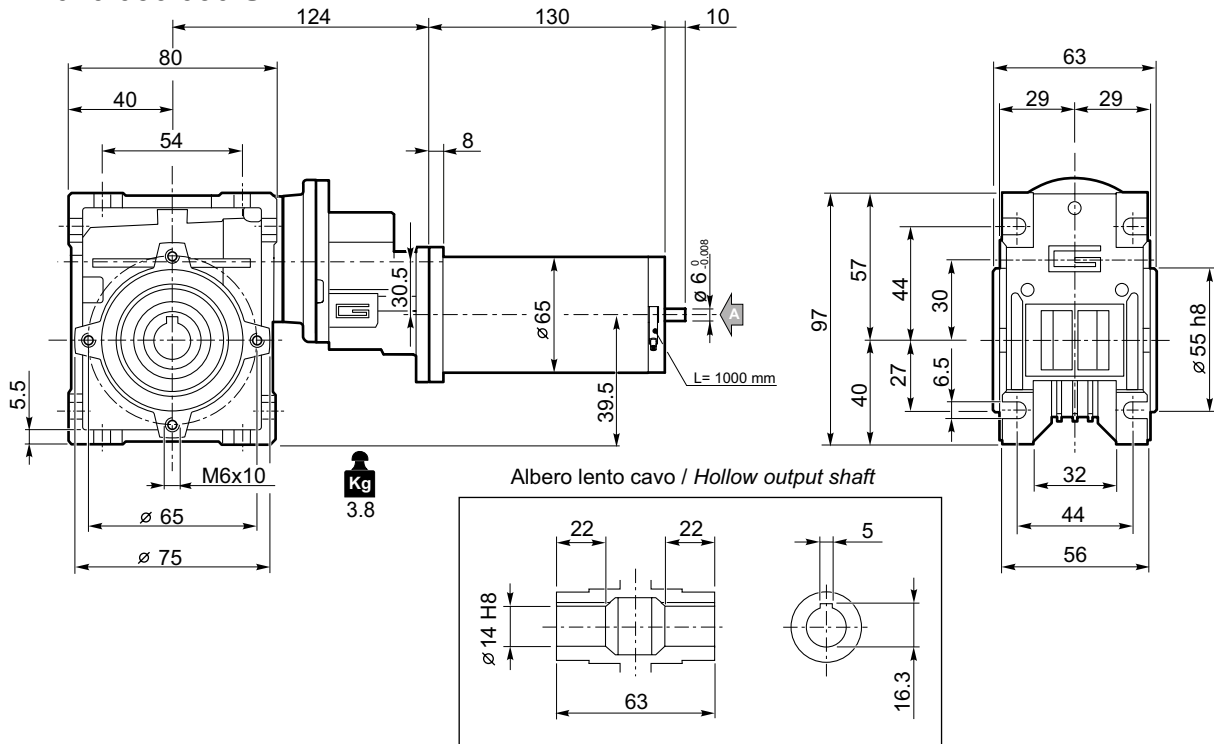

ECMP070/056/040 U

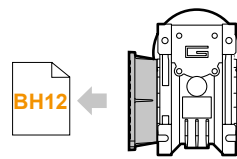
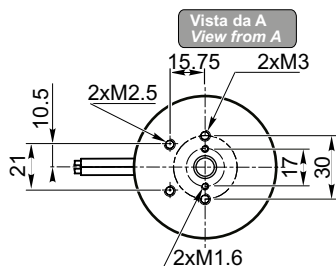
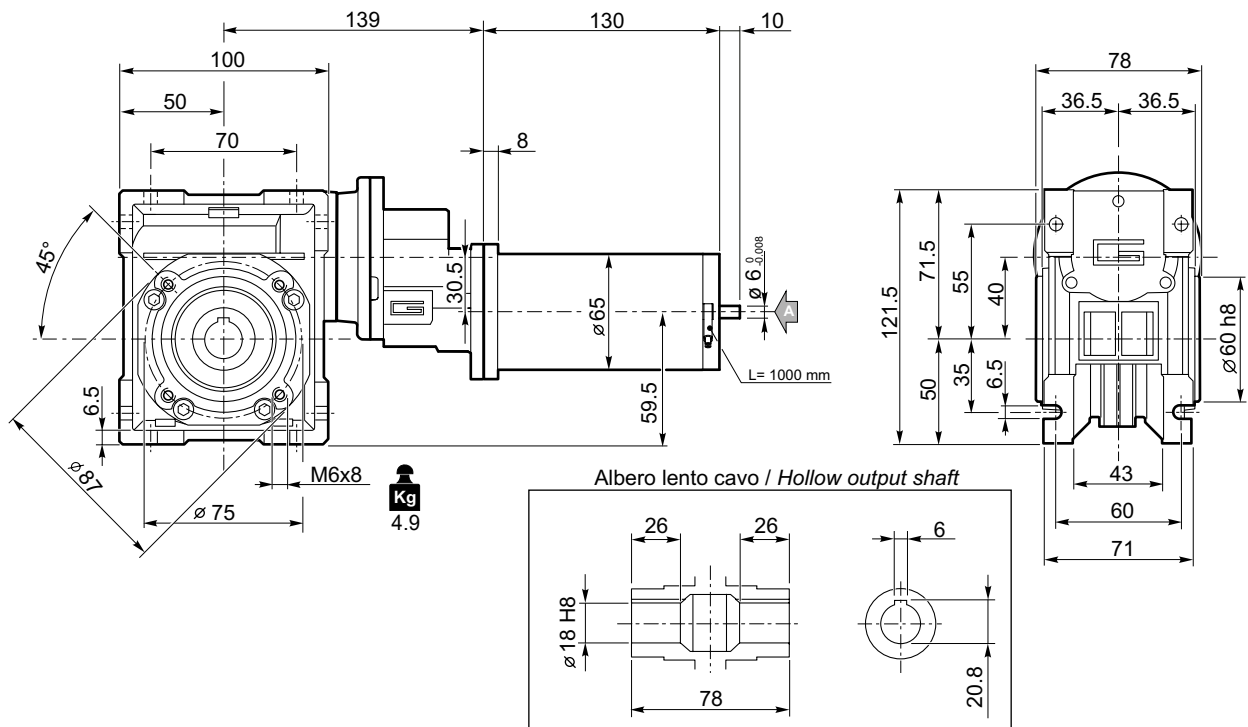

BH12
ECMP070/056/030 F
ECMP070/056/040 F..

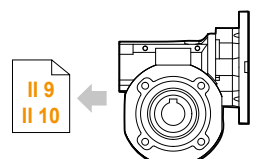

CL030
CL040

Motori / Motors IP66



Freno / Brake



Encoder



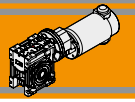

Dimensioni

Dimensions

ECMP100/056/030 U

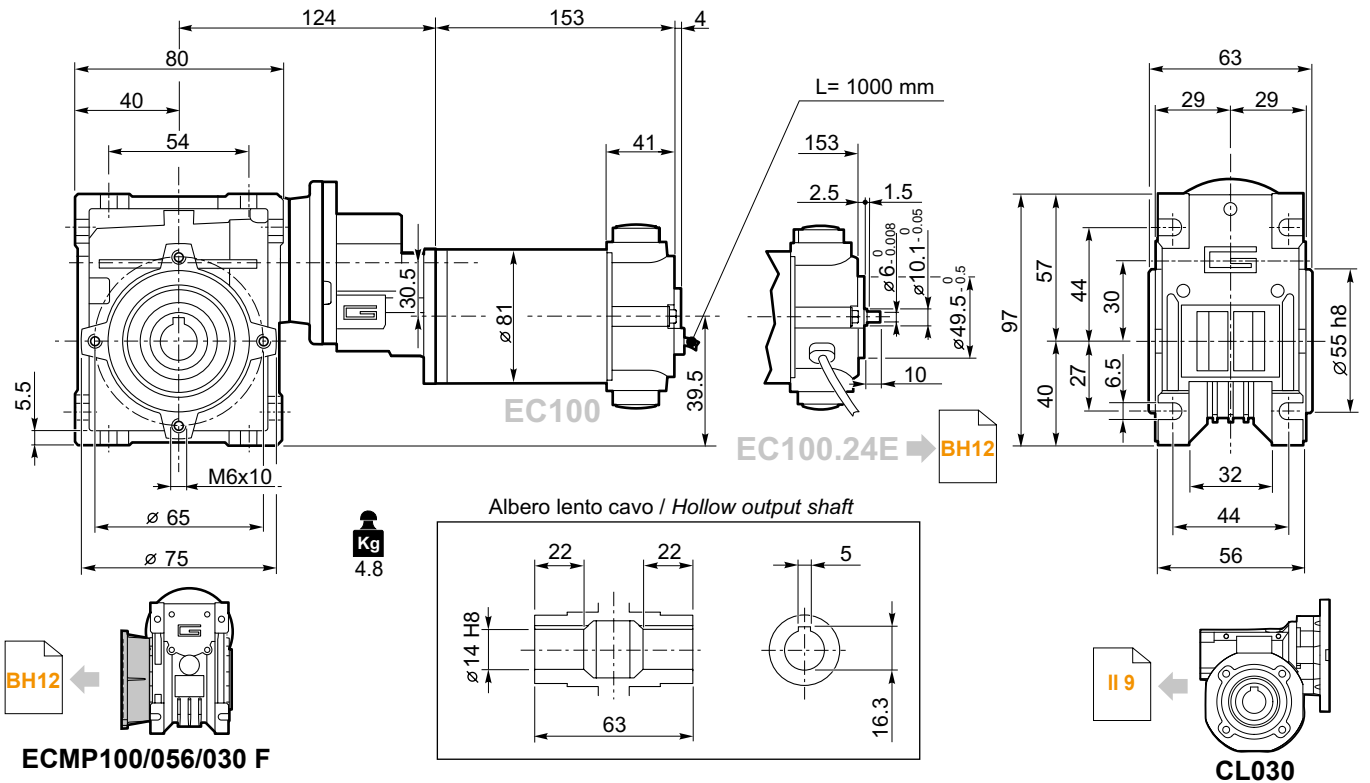

Motori / Motors IP66



Freno / Brake



Encoder



ECMP100/056/040 U

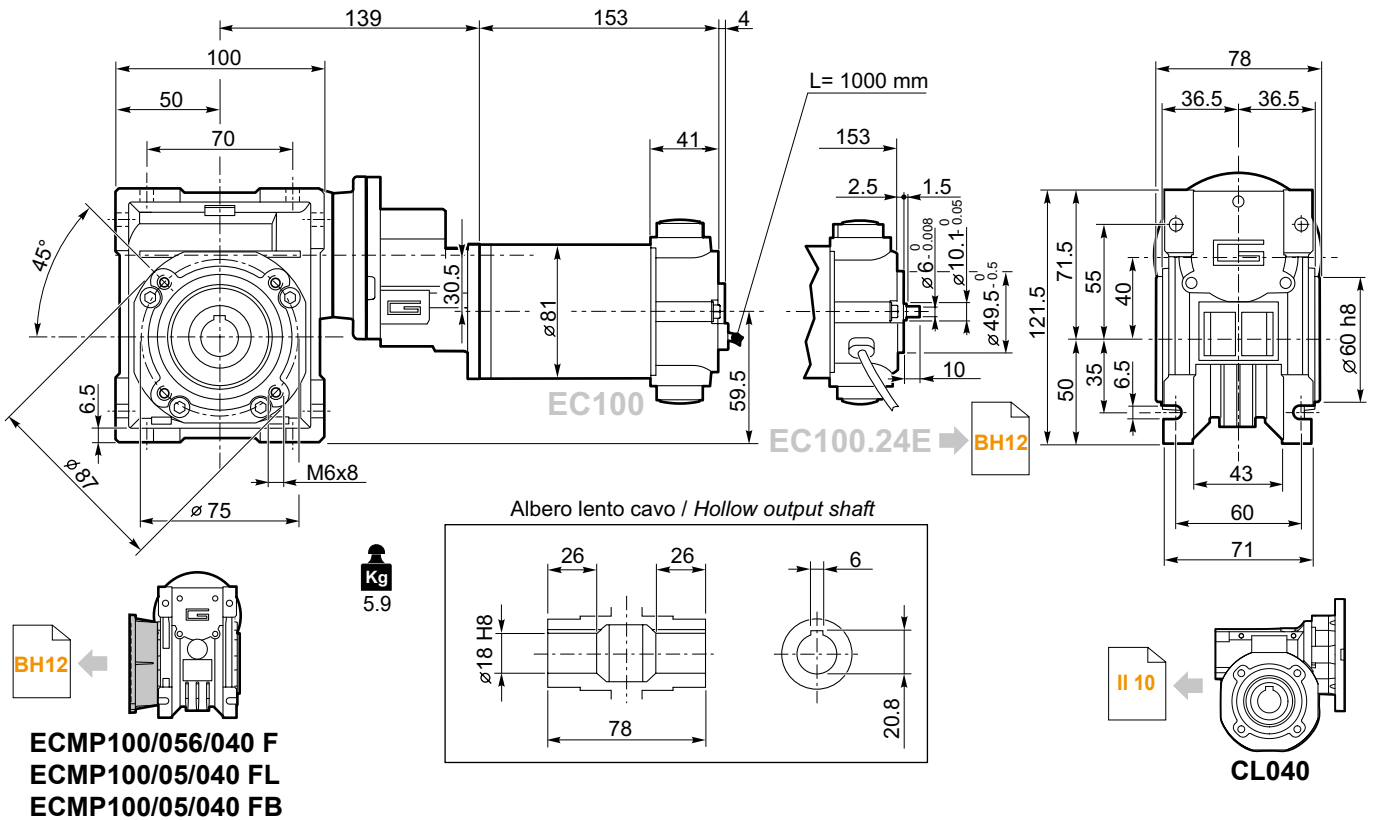

Motori / Motors IP66



Freno / Brake



Encoder



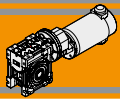

Dimensioni

Dimensions

ECMP180/056/030 U

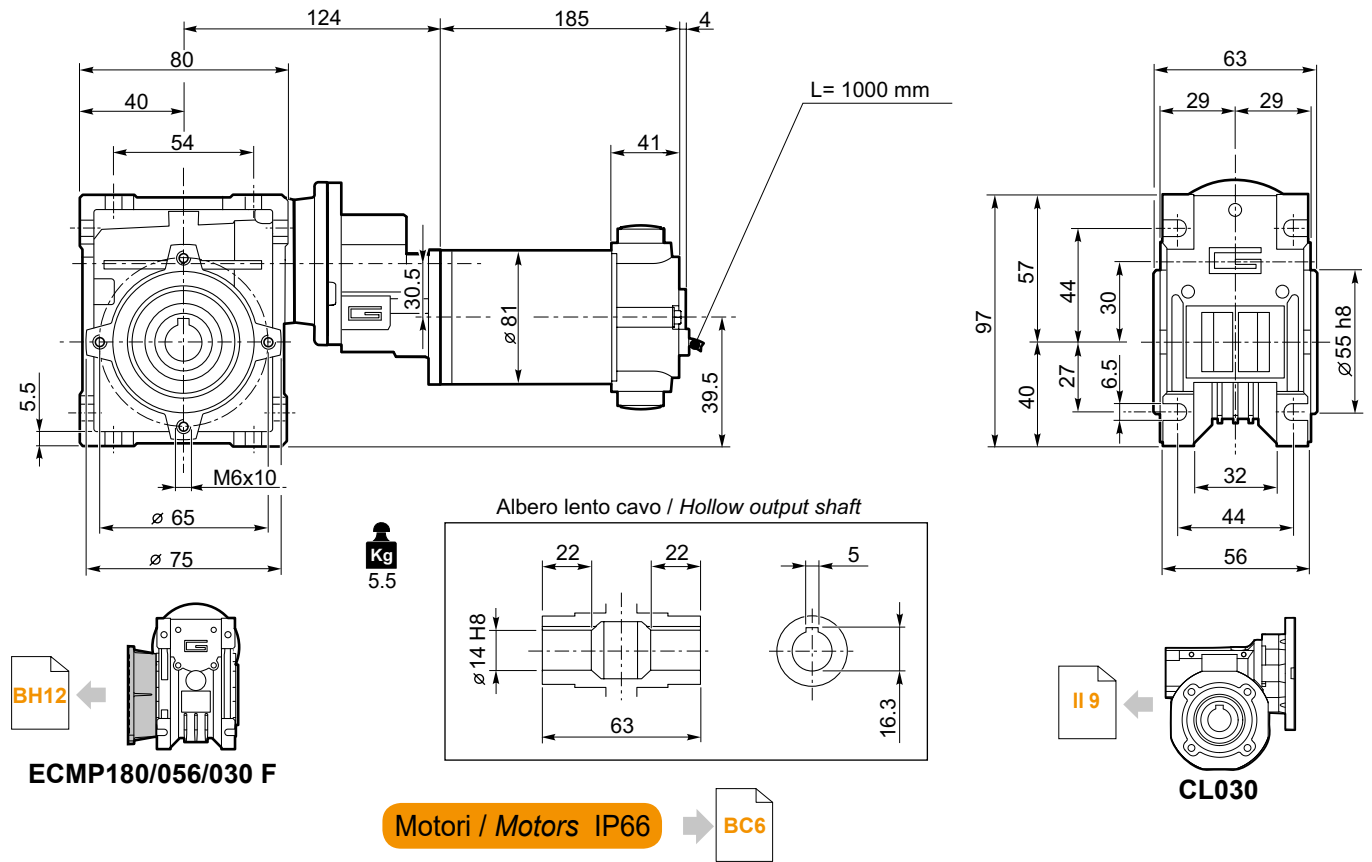

ECMP180/056/040 U

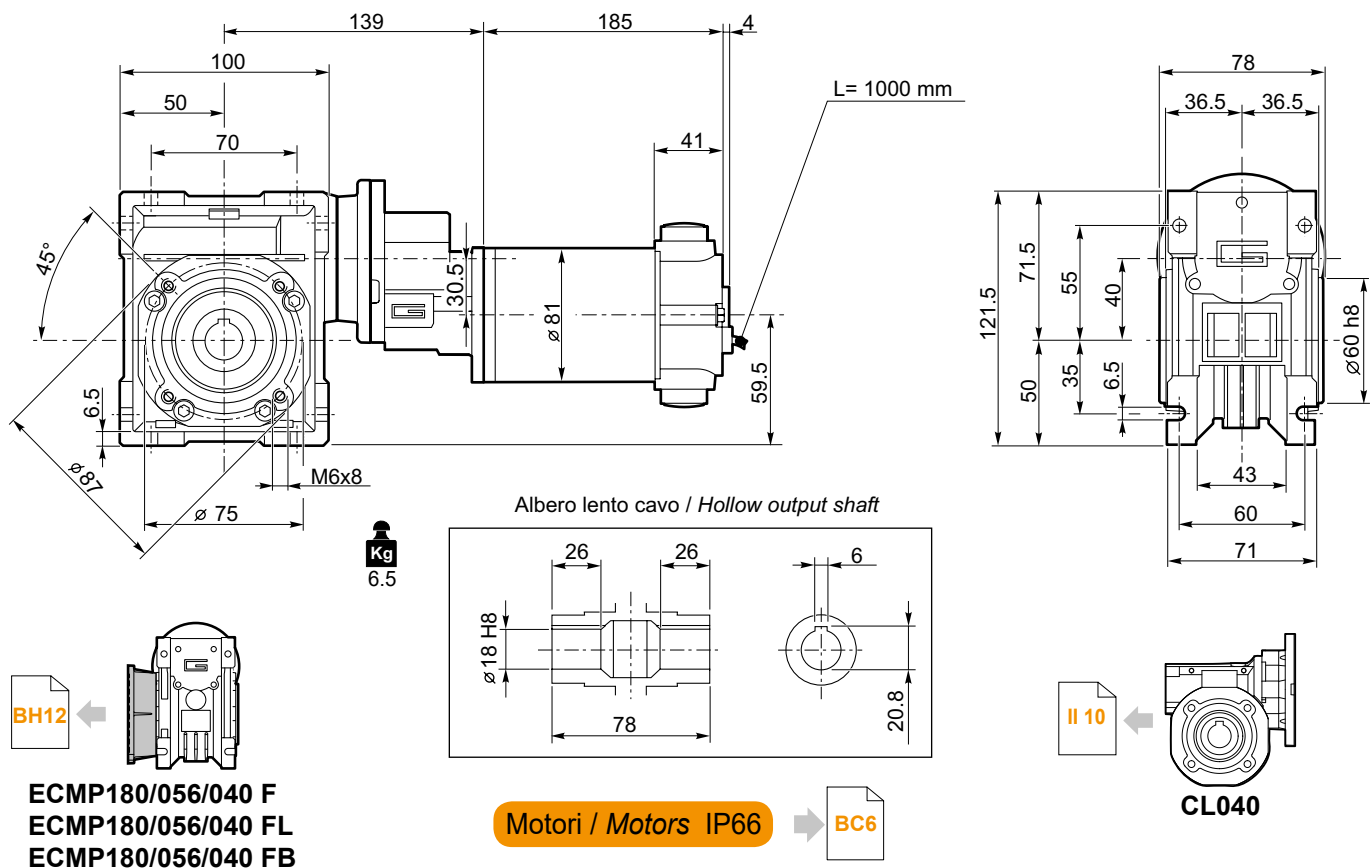

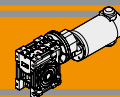

Dimensioni

Dimensions

ECMP180/063/040 U

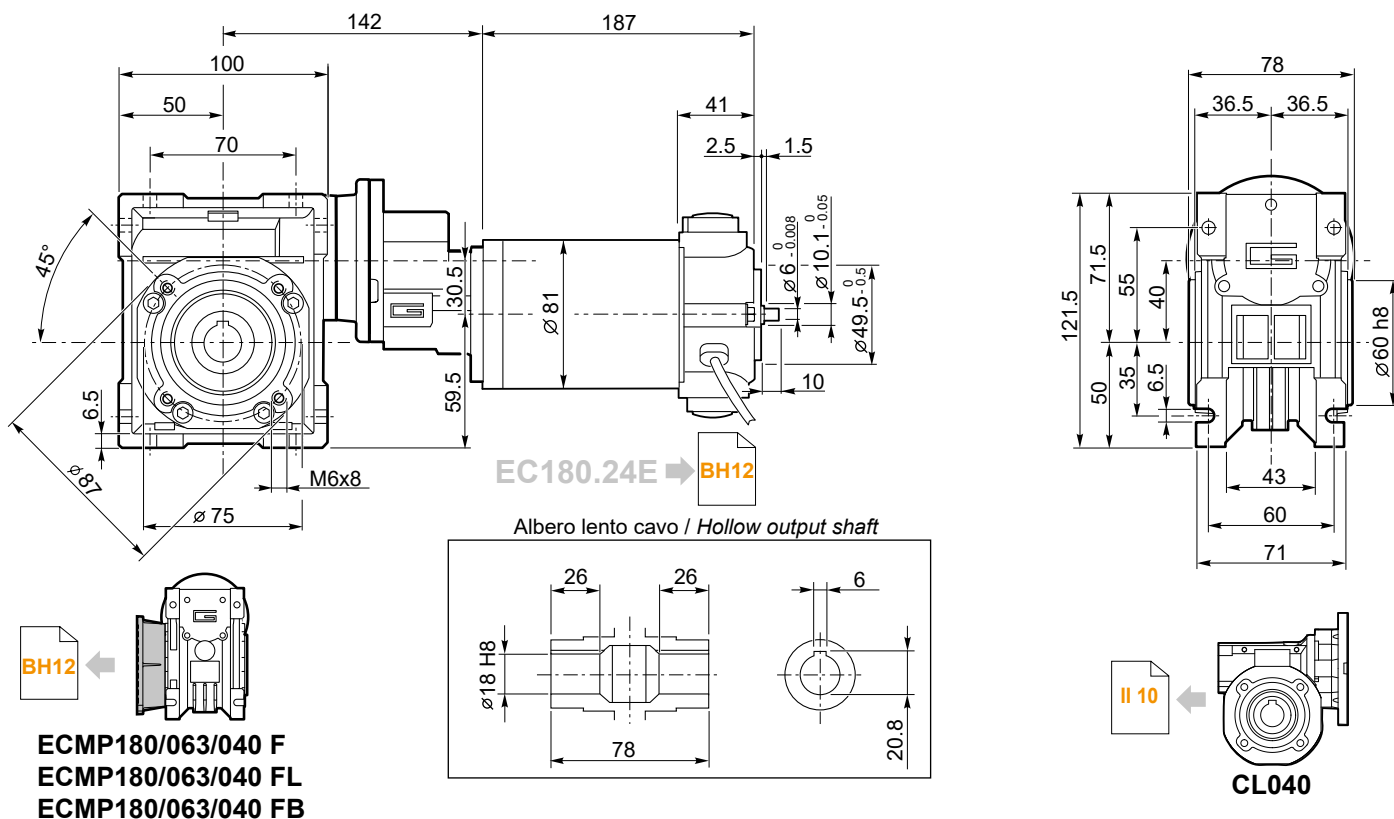

Motori / Motors IP66 → BC6

Freno / Brake → BB23

Encoder → BB24

ECMP250/063/040 U

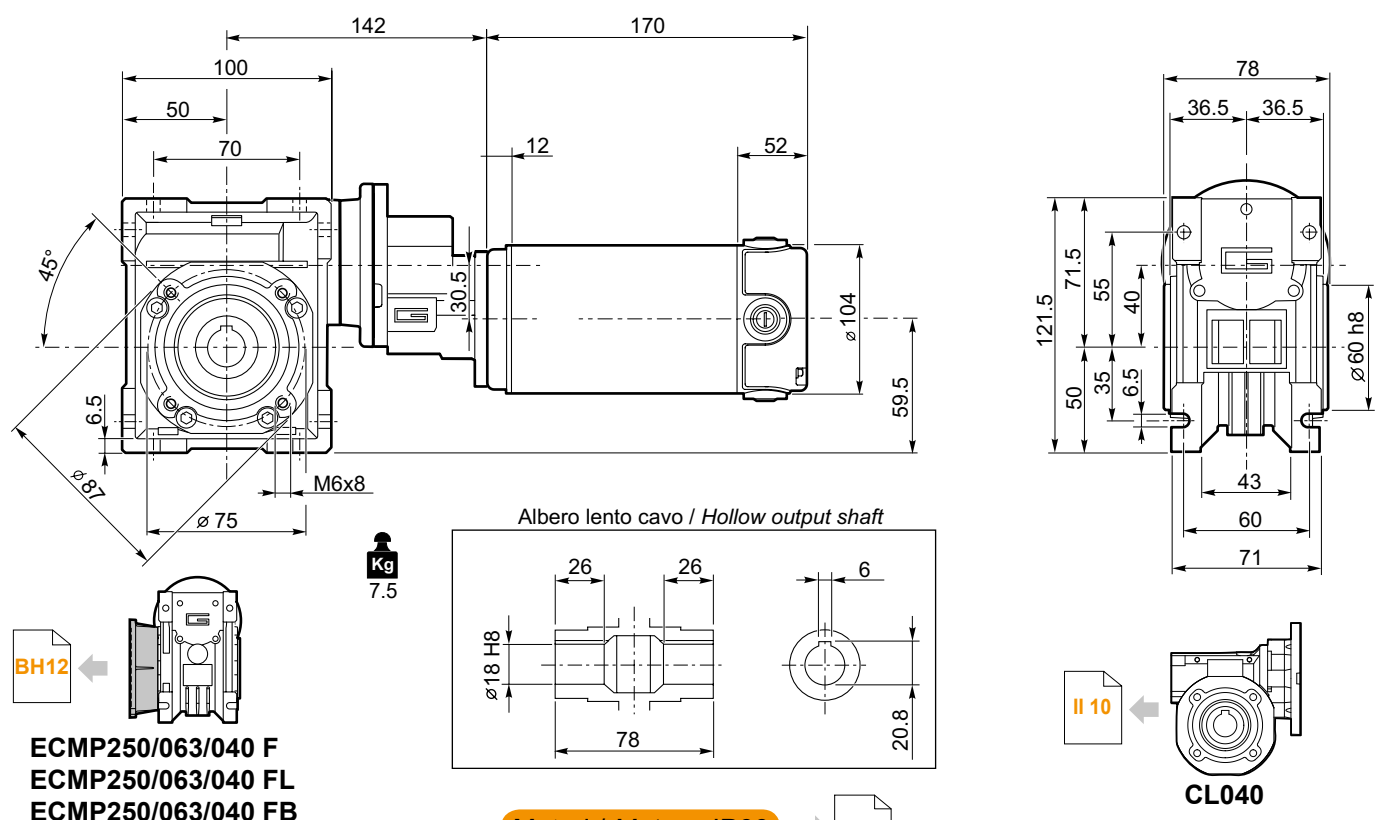

Motori / Motors IP66 → I8

DC

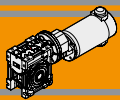

Dimensioni

Dimensions

EC100.24E
EC180.24E

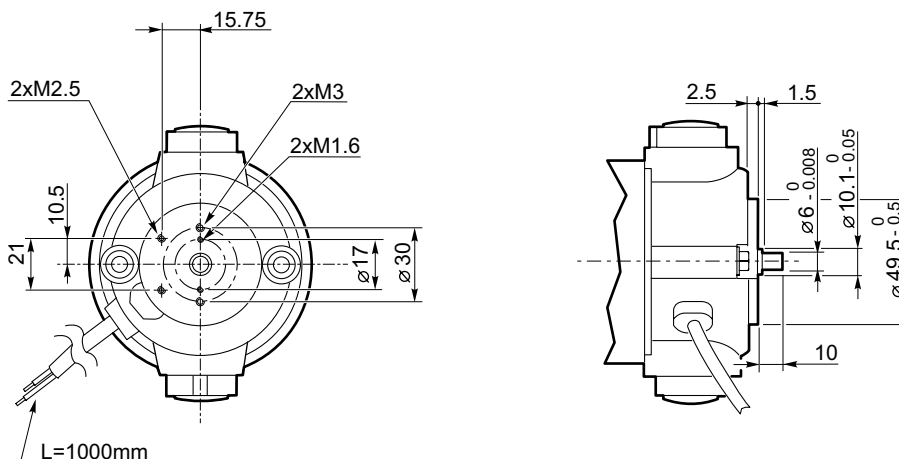

ECMP.../... F... Flange uscita / Output flanges

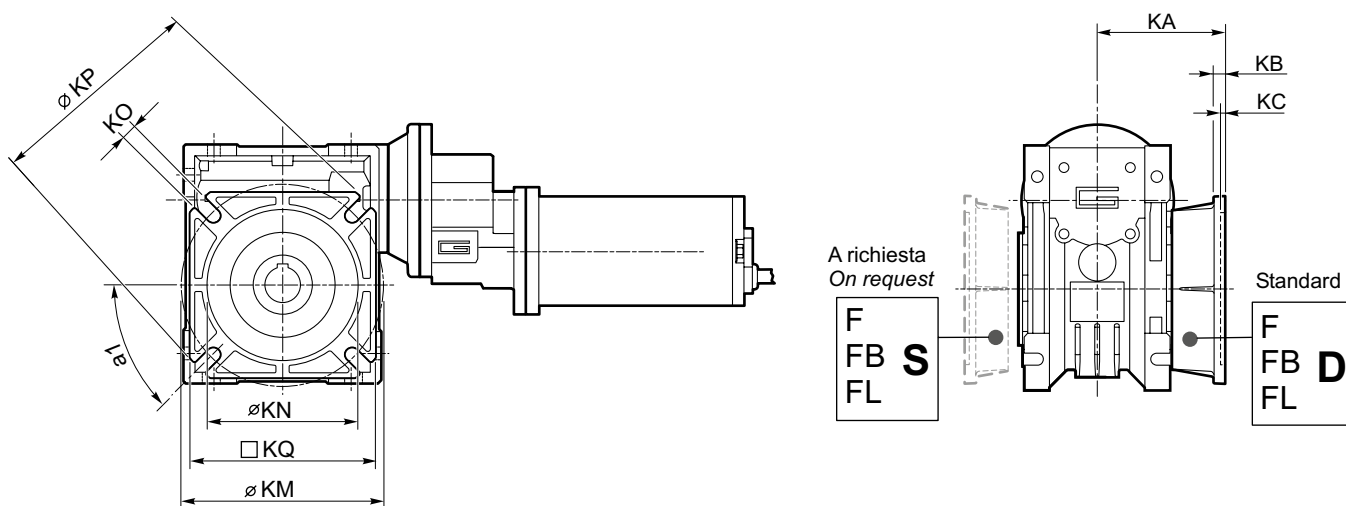

CMP	CMP..F								CMP..FB								CMP..FL								
	a1	KA	KB	KC	KM	KN _{H8}	KO	KP	KQ	KA	KB	KC	KM	KN _{H8}	KO	KP	KQ	KA	KB	KC	KM	KN _{H8}	KO	KP	KQ
056/030	45°	54.5	6	4	68	50	6.5(n.4)	80	70	—	—	—	—	—	—	—	—	—	—	—	—	—	—	—	—
056/040 063/040	45°	67	7.5	4	80-95	60	9(n.4)	110	95	80	8.5	5	115-125	95	9.5(n.4)	140	112	97	7.5	4.5	80-95	60	9(n.4)	110	95
063/050 071/050	45°	90	9	5	90-110	70	11(n.4)	125	110	89	9	5	130-145	110	9.5(n.4)	160	132	120	9	5	90-110	70	11(n.4)	125	110

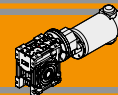

Opzioni

Options

VS - Vite sporgente / Extended input shaft

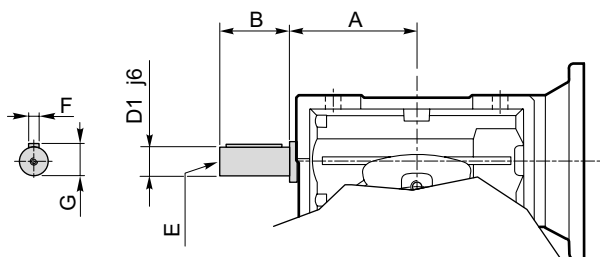

CMP	A	B	D ₁ j6	E	F	G
056/030	45	20	9	M4	3	10.2
056/040 063/040	53	23	11	M5	4	12.5

Costruito su richiesta
Built on request

SC - Safety cover

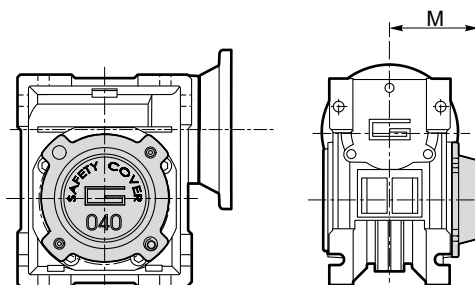

	M
CM 030	47
CM 040	54.5
CM 050	62.5
CM 063	73
CM 070	75
CM 075	79

Accessori

Accessories

Albero lento semplice e doppio

CMP	d h7	B	B1	G1	L	L1	f	b1	t1
056/030	14	30	32.5	63	102	128	M6	5	16
056/040 063/040	18	40	43	78	128	164	M6	6	20.5

Single and double output shaft

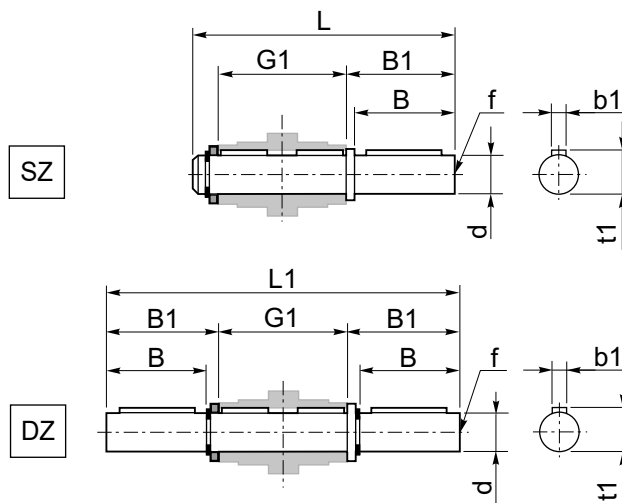

Braccio di reazione

CMP	K1	G	KG	KH	R
056/030	85	14	23	8	15
056/040 063/040	100	14	31	10	18

Torque arm

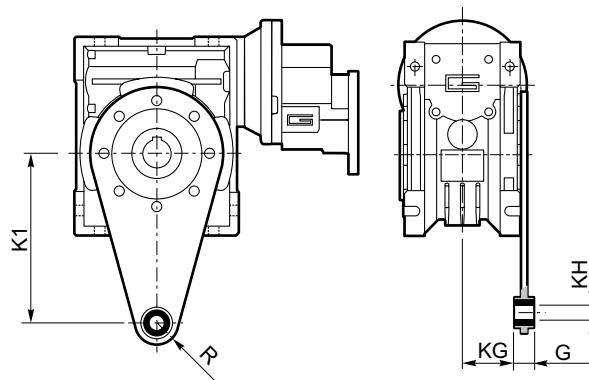

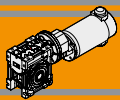

Note

MINI 
TECNO
small but strong

ECMM

Motoriduttori CC a vite senza fine combinati
DC double reduction wormgearmotors



MINI 
TECNO brand of
TRANSTECNO[®]



DC



Indice	Index	Pag. Page
Caratteristiche tecniche	<i>Technical features</i>	B12
Designazione	<i>Classification</i>	B12
Simbologia	<i>Symbols</i>	B12
Esecuzioni di montaggio	<i>Mounting executions</i>	B12
Combinazioni rapporti	<i>Combination ratio</i>	B13
Lubrificazione	<i>Lubrication</i>	B13
Dati tecnici per servizio S2	<i>Technical data for S2 duty</i>	B14
Motori applicabili	<i>Motor adapters</i>	B15
Dimensioni	<i>Dimensions</i>	B16
Accessori	<i>Accessories</i>	BI18
Opzioni	<i>Options</i>	BI18

Questa sezione annulla e sostituisce ogni precedente edizione o revisione. Qualora questa sezione non Vi sia giunta in distribuzione controllata, l'aggiornamento dei dati ivi contenuto non è assicurato. **In tal caso la versione più aggiornata è disponibile sul nostro sito internet www.transtecno.com**

This section replaces any previous edition and revision. If you obtained this catalogue other than through controlled distribution channels, the most up to date content is not guaranteed. In this case the latest version is available on our web site www.transtecno.com

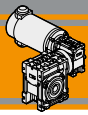
**ECMM**Motoriduttori CC a vite senza fine combinati
DC Double reduction wormgearmotors**Caratteristiche tecniche****Technical features**

I motoriduttori CC a vite senza fine combinati a magneti permanenti in ferrite **ECMM** hanno le seguenti caratteristiche principali:

- Alimentazione in bassa tensione 12/24Vcc
- Possibilità di montaggio encoder e freno
- Potenze motore disponibili da 100 a 500W S2
- Carcassa dei riduttori in pressofusione di alluminio.
- Lubrificazione permanente con olio sintetico

ECMM ferrite permanent magnets DC double reduction wormgearmotors range has the following main features:

- Low voltage power supply 12/24Vdc
- Suitable for encoder and brake assembly
- Motor power ratings available from 100 up to 800W S2
- Die cast aluminium housing
- Permanent synthetic oil long life lubrication

Designazione**Classification**

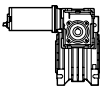
MOTORIDUTTORE / GEARMOTOR													
ECMM	100/026/026				U	150	SZDX	BRSX	90	B3	UB1	120	VS1
Tipo Type	Grandezza Size				Versione Version	Rapporto Ratio	Albero di uscita Output shaft	Braccio di reazione Torque arm	Angolo Angle	Pos. di montaggio Mounting position	Esecuzione di montaggio Mounting execution	Versione motore Motor version	Opzioni Options
	070/026/026 070/026/026 (D11) 070/026/026 (D14) 070/026/030 070/026/040	100/026/026 100/026/026 (D11) 100/026/026 (D14)	180/026/040 180/030/040	250/030/040 350/030/040	U F...	vedi tabelle see tables	SZDX SZSX DZ	BRDX BRSX *	0° 90° 180° 270°	B3 B8 B6 B7 V5 V6	UB1 UB2 US1 US2 UV1 UV2 UC1 UC2	120 240 24E	VS1 VS2

* NOTA: il braccio di reazione viene fornito smontato.
NOTE: the torque arm will be supplied not assembled.

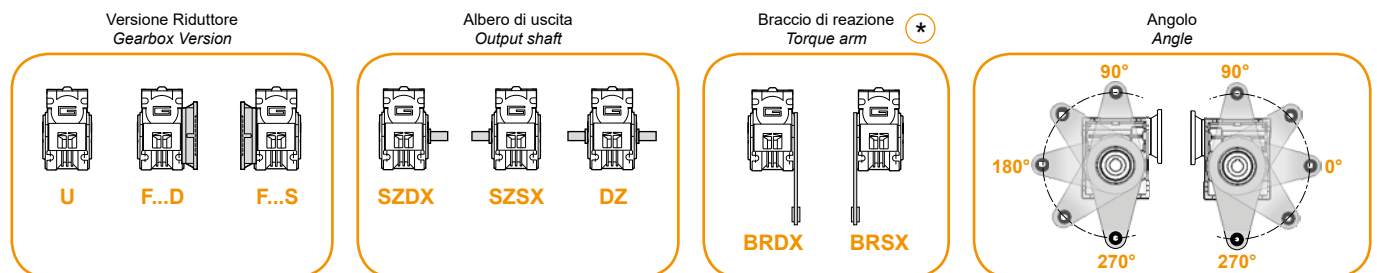
**Simbologia****Symbols**

n_1	[min^{-1}]	Velocità in ingresso / Input speed	M_2	[Nm]	Coppia in uscita in funzione di P_1 / Output torque referred to P_1
n_2	[min^{-1}]	Velocità in uscita / Output speed	sf		Fattore di servizio / Service factor
i		Rapporto di riduzione / Ratio	R_2	[N]	Carico radiale ammissibile in uscita / Permitted output radial load
P_1	[kW]	Potenza in entrata / Input power	A_2	[N]	Carico assiale ammissibile in uscita / Permitted output axial load

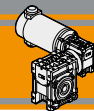

Esecuzioni di montaggio

Mounting executions

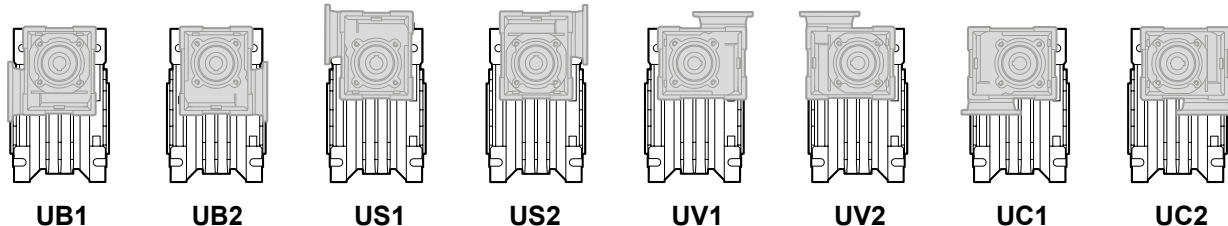

Combinazioni rapporti

Combination ratio

CMM 026/026 - CMM 026/030 - CMM 026/040												
i (i ₁ x i ₂)												
	150	225	300	450	600	900	1200	1500	1800	2400	3000	3600
i ₁	10	15	10	15	20	30	40	50	60	60	60	60
i ₂	15	15	30	30	30	30	30	30	30	40	50	60

CMM 030/040																
i (i ₁ x i ₂)																
	75	100	150	200	250	300	400	500	600	750	900	1200	1500	1800	2400	3000
i ₁	7.5	10	10	10	10	10	10	10	20	25	30	40	50	60	60	60
i ₂	10	10	15	20	25	30	40	50	30	30	30	30	30	30	40	50









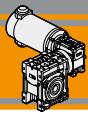

Lubrificazione

Lubrication

Tutti i motoriduttori nelle taglie 26, 30, 40 sono forniti completi di lubrificante sintetico viscosità 320, pertanto possono essere installati in qualunque posizione di montaggio e non necessitano di manutenzione.

Permanent synthetic oil long-life lubrication (viscosity grade 320) makes it possible to use the gearmotors size 26, 30, 40 in all mounting positions; for this reason they can be installed in any assembly position and do not require maintenance.

**Dati tecnici per servizio S2****Technical data for S2 duty**

P_1 [W]	n_2 [min ⁻¹]	M_2 [Nm]	sf	i		Versione motore Motor version	P_1 [W]	n_2 [min ⁻¹]	M_2 [Nm]	sf	i		Versione motore Motor version							
100							140													
(3000 min ⁻¹)	20.0	26	1.0	150		ECMM 070/026/026	12E/24E	(3000 min ⁻¹)	20.0	26	1.0	150		ECMM 100/026/026	120/240/24E					
	13.3	26	1.0	225							13.3	26				1.0	225			
	10.0	27	1.0	300							10.0	27				1.0	300			
	6.7	27	1.0	450							6.7	27				1.0	450			
	5.0	27	1.0	600							5.0	27				1.0	600			
	3.3	27	1.0	900							3.3	27				1.0	900			
	2.5	27	1.0	1200							2.5	27				1.0	1200			
	2.0	27	1.0	1500							2.0	27				1.0	1500			
	1.7	27	1.0	1800							1.7	27				1.0	1800			
	1.3	22	1.0	2400							1.3	22				1.0	2400			
	1.0	20	1.0	3000							1.0	20				1.0	3000			
	0.8	18	1.0	3600							0.8	18				1.0	3600			
	20.0	26	1.5	150					ECMM 070/026/030	12E/24E		20.0				37	1.1	150		ECMM 100/026/030
	13.3	39	1.0	225							13.3	39	1.0	225						
	10.0	40	1.0	300							10.0	40	1.0	300						
	6.7	40	1.0	450							6.7	40	1.0	450						
	5.0	40	1.0	600							5.0	40	1.0	600						
	3.3	40	1.0	900							3.3	40	1.0	900						
	2.5	40	1.0	1200							2.5	40	1.0	1200						
	2.0	40	1.0	1500							2.0	40	1.0	1500						
	1.7	40	1.0	1800							1.7	40	1.0	1800						
	1.3	34	1.0	2400							1.3	34	1.0	2400						
	1.0	30	1.0	3000							1.0	30	1.0	3000						
	0.8	27	1.0	3600							0.8	27	1.0	3600						
	20.0	27	3.2	150		ECMM 070/026/040	12E/24E					20.0	38	2.3	150		ECMM 100/026/040	120/240/24E		
	13.3	40	2.2	225							13.3	55	1.6	225						
	10.0	45	2.0	300							10.0	63	1.4	300						
	6.7	66	1.4	450							6.7	92	1.0	450						
	5.0	85	1.1	600							5.0	90	1.0	600						
	3.3	90	1.0	900							3.3	90	1.0	900						
	2.5	90	1.0	1200							2.5	90	1.0	1200						
	2.0	90	1.0	1500							2.0	90	1.0	1500						
	1.7	90	1.0	1800							1.7	90	1.0	1800						
	1.3	74	1.0	2400							1.3	74	1.0	2400						
	1.0	68	1.0	3000							1.0	68	1.0	3000						
	0.8	62	1.0	3600							0.8	62	1.0	3600						
	40.0	15	5.5	75					ECMM 070/030/040	12E/24E		40.0	21	3.9	75					ECMM 100/030/040
	30.0	20	4.2	100							30.0	28	3.0	100						
	20.0	28	3.2	150							20.0	38	2.3	150						
	15.0	36	2.1	200							15.0	50	1.5	200						
	12.0	43	1.6	250							12.0	59	1.1	250						
	10.0	46	2.0	300							10.0	63	1.4	300						
	7.5	55	1.3	400							7.5	77	1.0	400						
	6.0	63	1.1	500							6.0	87	0.8	500						
	5.0	86	1.0	600							5.0	119	0.8	600						
	4.0	103	0.9	750							4.0	90	1.0	750						
	3.3	118	0.8	900							3.3	90	1.0	900						
	2.5	74	1.0	1200							2.5	74	1.0	1200						
	2.0	90	1.0	1500							2.0	90	1.0	1500						
	1.7	90	1.0	1800				1.7	90	1.0	1800									
	1.3	74	1.0	2400				1.3	74	1.0	2400									
	1.0	68	1.0	3000				1.0	68	1.0	3000									





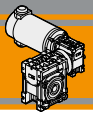

Nota: Verificare sempre che la coppia M2 utilizzata non ecceda il valore indicato nelle caselle in grigio

Note: Please check that the output torque M2 does not exceed the value into the grey areas



Dati tecnici per servizio S2

Technical data for S2 duty

P_1 [W]	n_2 [min ⁻¹]	M_2 [Nm]	sf	i		Versione motore Motor version	P_1 [W]	n_2 [min ⁻¹]	M_2 [Nm]	sf	i		Versione motore Motor version						
250							350												
(3000 min ⁻¹)	20.0	70	1.2	150		ECMM 180/026/040	120/240	(3000 min ⁻¹)	40.0	55	1.5	75		ECMM 250/030/040	120/240				
	13.3	103	0.8	225															
	10.0	116	0.8	300															
	40.0	40	2.1	75		ECMM 180/030/040	120/240/24E		30.0	72	1.2	100							
	30.0	52	1.6	100															
	20.0	71	1.2	150															
	15.0	92	0.8	200															
	12.0	67	1.0	250															
	10.0	90	1.0	300															
	7.5	74	1.0	400															
	6.0	68	1.0	500															
	5.0	90	1.0	600															
	4.0	90	1.0	750															
	3.3	90	1.0	900															
500							500												
(3000 min ⁻¹)	40.0	78	1.1	75		ECMM 350/030/040	120/240	(3000 min ⁻¹)	40.0	78	1.1	75		ECMM 350/030/040	120/240				
	30.0	101	0.8	100															
	20.0	87	1.0	150															

Motori applicabili

Motor adapters

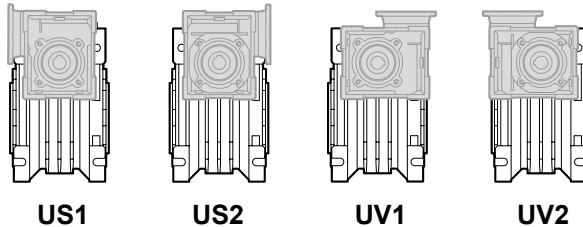

US1

US2

UV1

UV2

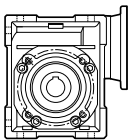
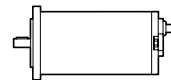

		EC			
		070.12E 070.24E	100.120 100.240	100.24E	180.120 180.240
CMM	026/026	150 - 3600	150 - 3600	150 - 3600	150 - 3600

150 - 3600

Rapporti di riduzione i
Ratio i

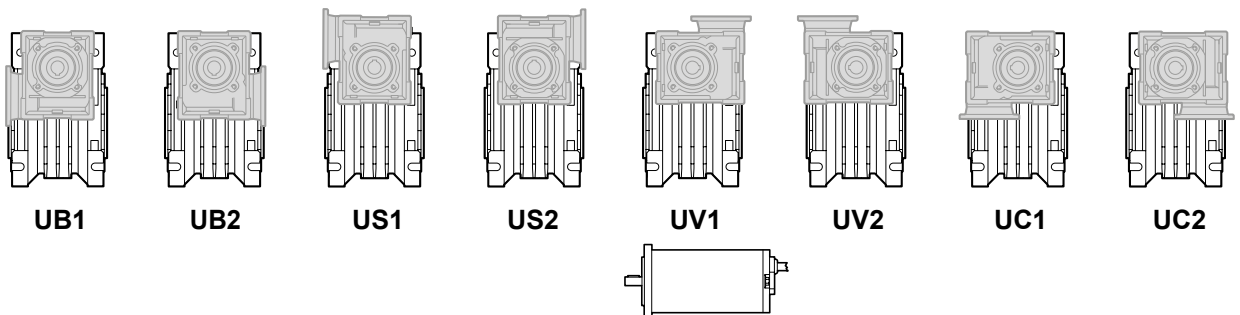

UB1

UB2

US1

US2

UV1

UV2

UC1

UC2

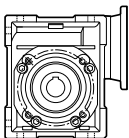
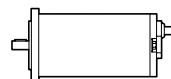

		EC						
		070.12E 070.24E	100.120 100.240	100.24E	180.120 180.240	180.24E	250.120 250.240	350.120 350.240
CMM	026/030	150 - 3600	150 - 3600	150 - 3600	150 - 3600			
	026/040	150 - 3600	150 - 3600	150 - 3600	150 - 3600			
	030/040	75 - 3000	75 - 3000	75 - 3000	75 - 3000	75 - 1500	75 - 1500	75 - 1500

75 - 1500

Rapporti di riduzione i
Ratio i

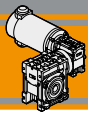

Dimensioni

Dimensions

CMM..U - CMM..F..																	
	A	C	D _{H8}	E	F	G	G1	H	H1	I	I1	K	L	M	N _{h8}	N1	N2
026/026 (D11)	45	70	11	83	22	47.5	50	35	34	26	26	34	42	55	45	22.5	21
026/026			12														
026/026 (D14)			14														
026/030	54	80	14	97	32	47.5	63	40	34	30	26	44	56	65	55	29	21
026/040	70	100	18	121.5	43	47.5	78	50	34	40	26	60	71	75	60	36.5	21
030/040	70	100	18	121.5	43	55	78	50	40	40	30	60	71	75	60	36.5	29

CMM..U - CMM..F..															
	O	P	Q	R	R1	S	T	V	Z	KE	a	b	t	Kg (*)	
026/026 (D11)	6	—	37	49	49	5	15	21	76	7	—	4	12.8	3.3	
026/026												4	13.8		
026/026 (D14)												5	16.2		
026/030	6.5	75	44	57	49	5.5	22	27	81	M6x10(n.4)	90°	5	16.3	4.1	
026/040	6.5	87	55	71.5	49	6.5	26	35	91.5	M6x8(n.4)	45°	6	20.8	5.2	
030/040	6.5	87	55	71.5	57	6.5	26	35	122	M6x8(n.4)	45°	6	20.8	5.6	

(*) **Nota:** Il peso in kg si riferisce al motoriduttore ECMM 070 /...
Note: The weight in kg is referred to the gearmotor ECMM 070 /...

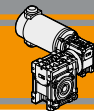

Dimensioni

Dimensions

ECMM070/...U

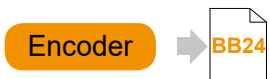
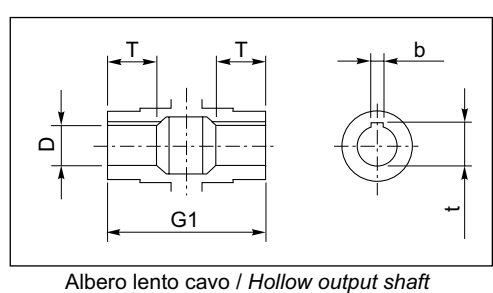
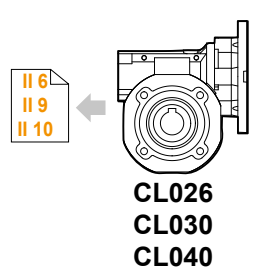
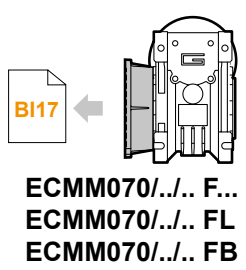
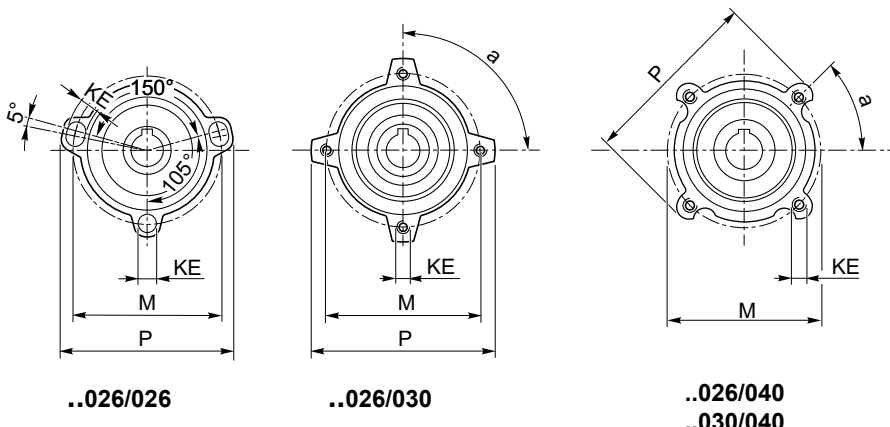
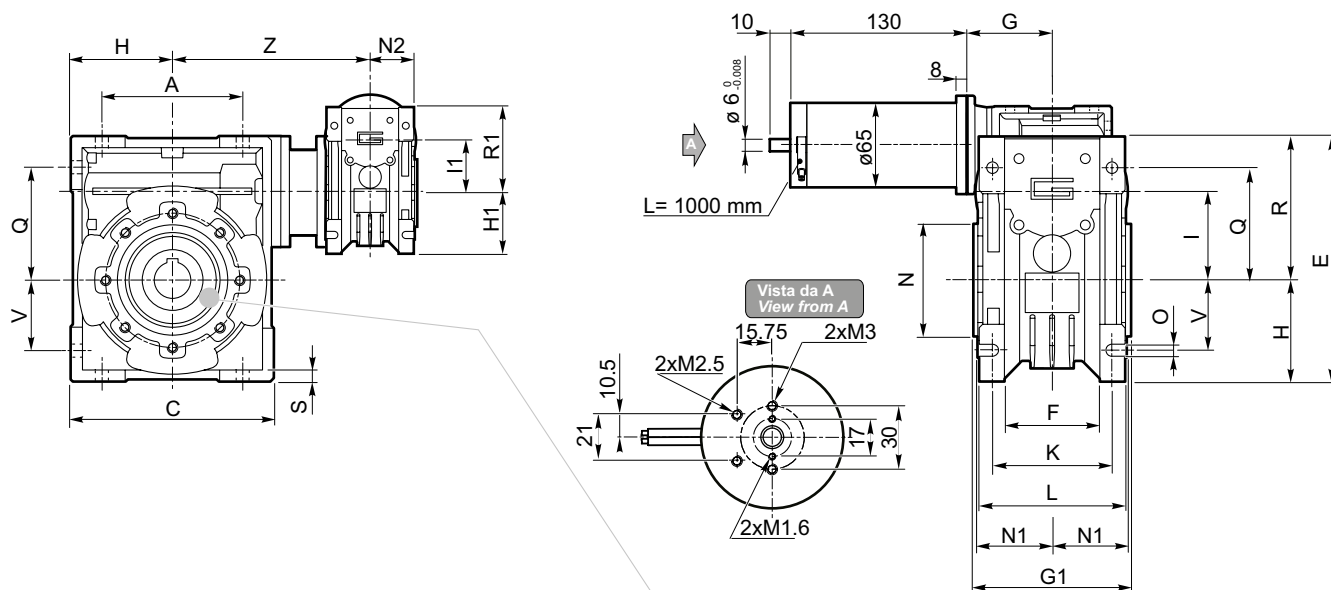

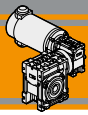
**Dimensioni****Dimensions**

CMM..U - CMM..F...																	
	A	C	D _{H8}	E	F	G	G1	H	H1	I	I1	K	L	M	N _{H8}	N1	N2
026/026 (D11)	45	70	11	83	22	47.5	50	35	34	26	26	34	42	55	45	22.5	21
026/026			12														
026/026 (D14)			14														
026/030	54	80	14	97	32	47.5	63	40	34	30	26	44	56	65	55	29	21
026/040	70	100	18	121.5	43	47.5	78	50	34	40	26	60	71	75	60	36.5	21
030/040	70	100	18	121.5	43	55	78	50	40	40	30	60	71	75	60	36.5	29

CMM..U - CMM..F...														
	O	P	Q	R	R1	S	T	V	Z	KE	a	b	t	Kg (*)
026/026 (D11)	6	—	37	49	49	5	15	21	76	7	—	4	12.8	3.3
026/026												4	13.8	
026/026 (D14)												5	16.2	
026/030	6.5	75	44	57	49	5.5	22	27	81	M6x10(n.4)	90°	5	16.3	5.1
026/040	6.5	87	55	71.5	49	6.5	26	35	91.5	M6x8(n.4)	45°	6	20.8	6.2
030/040	6.5	87	55	71.5	57	6.5	26	35	122	M6x8(n.4)	45°	6	20.8	6.6

(*) **Nota:** Il peso in kg si riferisce al motoriduttore ECMM 100 /...

Note: The weight in kg is referred to the gearmotor ECMM 100 /...

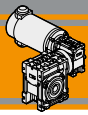
**Dimensioni****Dimensions**

CMM..U - CMM..F - CMM..FB - CMM..FL																	
	A	C	D _{H8}	E	F	G	G1	H	H1	I	I1	K	L	M	N _{H8}	N1	N2
026/040	70	100	18	121.5	43	47.5	78	50	34	40	26	60	71	75	60	36.5	21
030/040	70	100	18	121.5	43	55	78	50	40	40	30	60	71	75	60	36.5	29

CMM..U - CMM..F - CMM..FB - CMM..FL														
	O	P	Q	R	R1	S	T	V	Z	KE	a	b	t	Kg (*)
026/040	6.5	87	55	71.5	49	6.5	26	35	91.5	M6x8(n.4)	45°	6	20.8	6.9
030/040	6.5	87	55	71.5	57	6.5	26	35	122	M6x8(n.4)	45°	6	20.8	7.3

(*) **Nota:** Il peso in kg si riferisce al motoriduttore ECMM 180 /...

Note: The weight in kg is referred to the gearmotor ECMM 180 /...

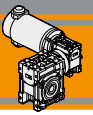

Dimensioni

Dimensions

ECMM180/...U

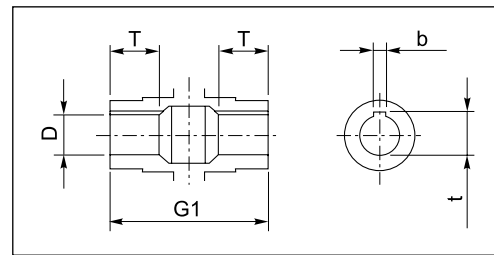
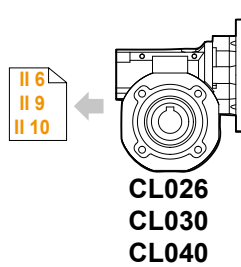
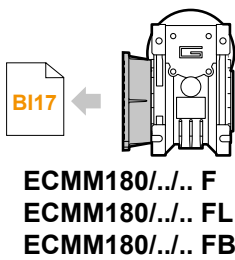
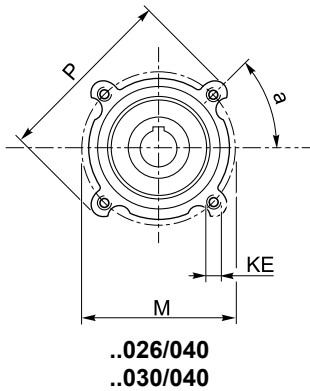
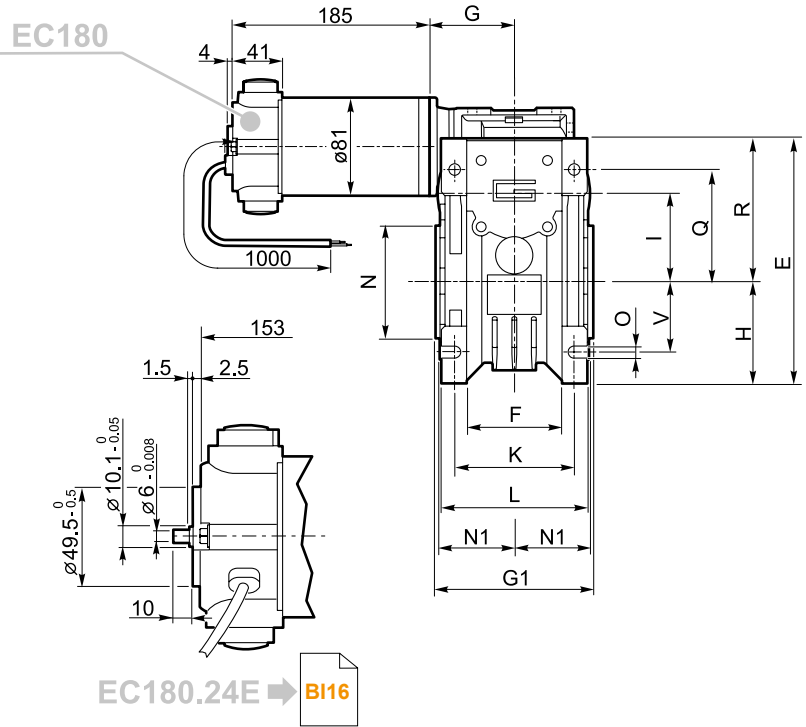
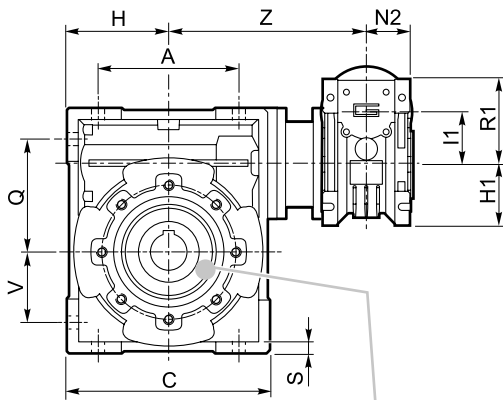

Albero lento cavo / Hollow output shaft

Motori / Motors IP66 → **BC6**

Freno / Brake → **BB23**

Encoder → **BB24**

**Dimensioni****Dimensions**

CMM..U - CMM..F - CMM..FB - CMM..FL																	
	A	C	D _{H8}	E	F	G	G1	H	H1	I	I1	K	L	M	N _{H8}	N1	N2
030/040	70	100	18	121.5	43	55	78	50	40	40	30	60	71	75	60	36.5	29

CMM..U - CMM..F - CMM..FB - CMM..FL															
	O	P	Q	R	R1	S	T	V	Z	KE	a	b	t	kg (*)	
030/040	6.5	87	55	71.5	57	6.5	26	35	122	M6x8(n.4)	45°	6	20.8	8.2	

(*) **Nota:** Il peso in kg si riferisce al motoriduttore ECMM 250 /...

Note: The weight in kg is referred to the gearmotor ECMM 250 /...

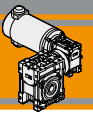

Dimensioni

Dimensions

ECMM250/...U

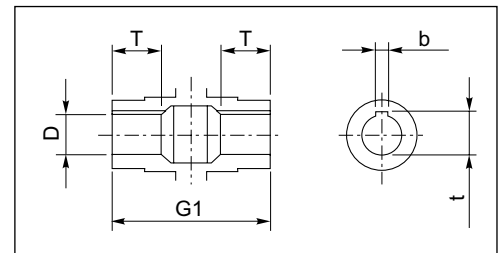
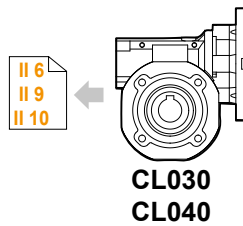
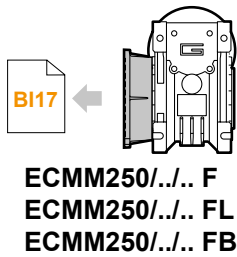
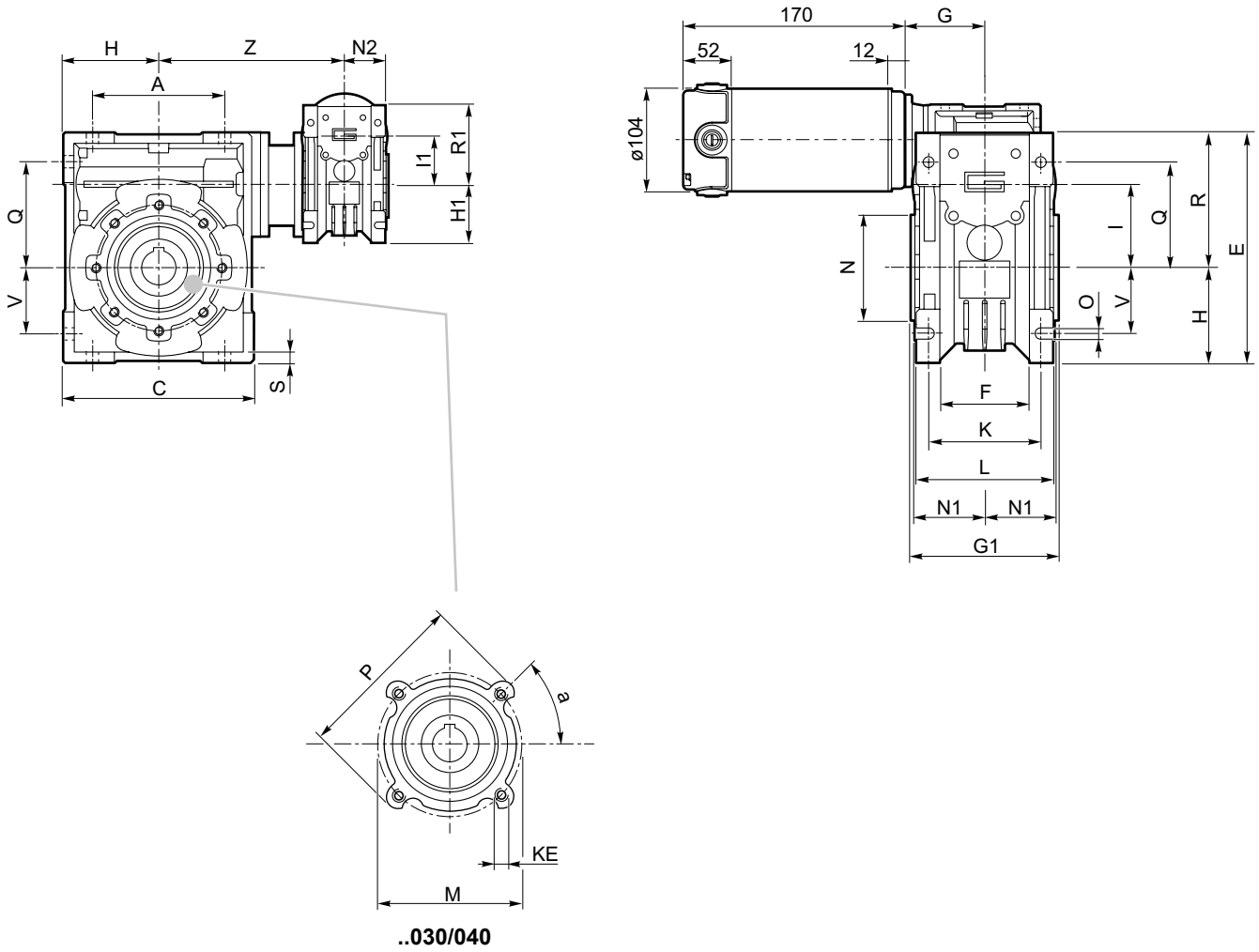

Albero lento cavo / Hollow output shaft

Motori / Motors IP66

BC8

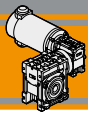
**Dimensioni****Dimensions**

CMM..U - CMM..F - CMM..FB - CMM..FL																	
	A	C	D _{H8}	E	F	G	G1	H	H1	I	I1	K	L	M	N _{H8}	N1	N2
030/040	70	100	18	121.5	43	55	78	50	40	40	30	60	71	75	60	36.5	29

CMM..U - CMM..F - CMM..FB - CMM..FL														
	O	P	Q	R	R1	S	T	V	Z	KE	a	b	t	Kg (*)
030/040	6.5	87	55	71.5	57	6.5	26	35	122	M6x8(n.4)	45°	6	20.8	9.2

(*) **Nota:** Il peso in kg si riferisce al motoriduttore ECMM 350 /...

Note: The weight in kg is referred to the gearmotor ECMM 350 /...

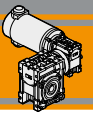

Dimensioni

Dimensions

ECMM350/...U

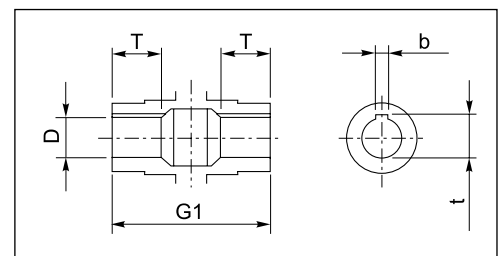
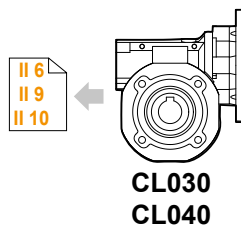
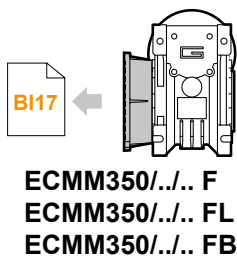
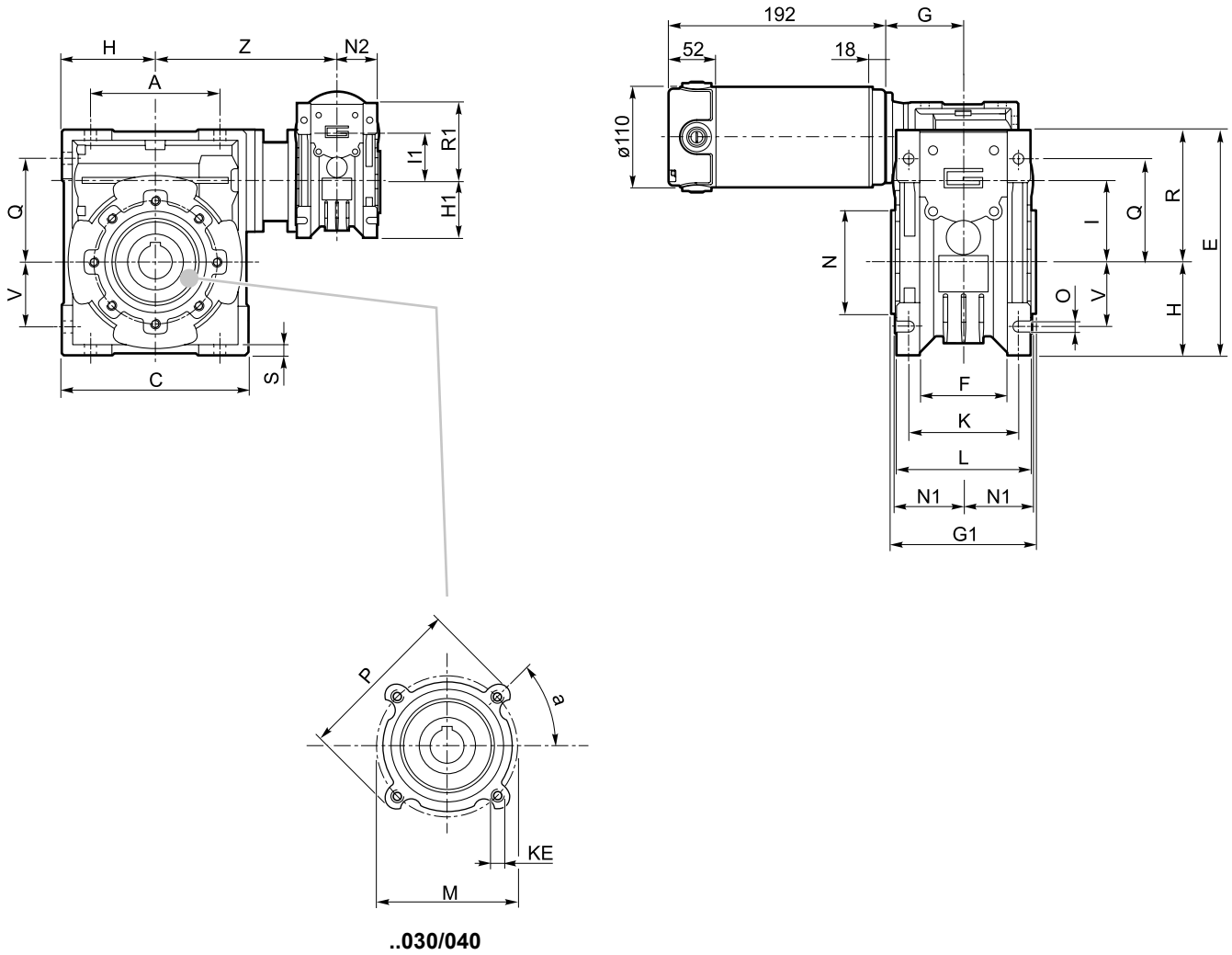

Albero lento cavo / Hollow output shaft



DC

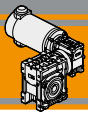

Dimensioni

Dimensions

EC100.24E
EC180.24E

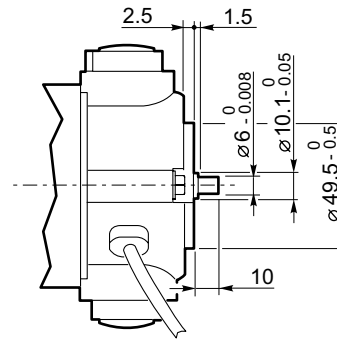
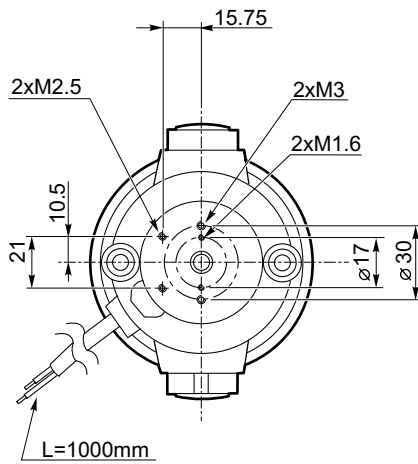

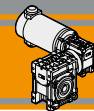

Dimensioni

Dimensions

ECMM.../... F... Flange uscita / Output flanges

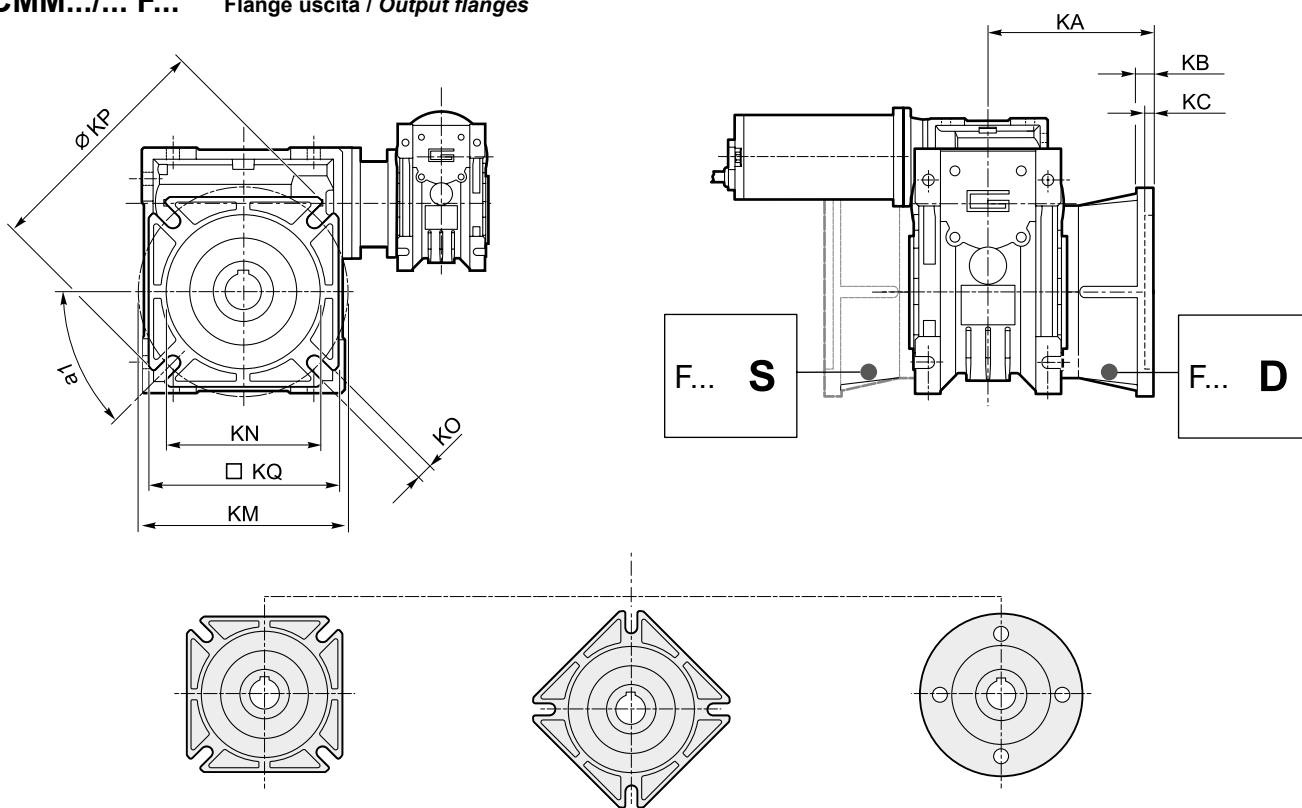

- ..ECMM.../.../026.. F
- ..ECMM.../.../026.. F28
- ..ECMM.../.../026.. F30
- ..ECMM.../.../026.. F30S
- ...ECMM.../.../030.. F..
- ..ECMM.../.../040.. F..
- ..ECMM.../.../026.. F30C
- ..ECMM.../.../026.. F30SC
- ..ECMM.../.../026.. F100

	CM..F						CM..F28						CM..F30						CM..F30S ⁽¹⁾														
	a1	KA	KB	KC	KM	KN _{H8}	KO	KP	KQ	KA	KB	KC	KM	KN _{H8}	KO	KP	KQ	KA	KB	KC	KM	KN _{H8}	KO	KP	KQ	KA	KB	KC	KM	KN _{H8}	KO	KP	KQ
026 (D11)	45°	45	6	4.5	55-69	40	6.5	75	70	44	6.5	5	56-64	40	6.5	70	60	48	6.5	5	68	50	6.5	80	70	50	8.5	7	68	50	6.5	80	70
026							(n.4)																										
026 (D14)																																	

(1): F30S eseguita con F30 e distanziale di spessore 2 mm / F30S made with F30 and spacer with 2mm thickness

	CM..F30C						CM..F30SC ⁽²⁾						CM..F100												
	a1	KA	KB	KC	KM	KN _{H8}	KO	KP	KQ	KA	KB	KC	KM	KN _{H8}	KO	KP	KQ	KA	KB	KC *	KM	KN _{H7}	KO	KP	KQ
026 (D11)	-	48	6.5	7	68	50	6.5	80	70	50	8.5	7	68	50	6.5	80	70	51.5	8	2 *	86	45	6.5	100	-
026																									
026 (D14)																									

(2): F30SC eseguita con F30C e distanziale di spessore 2 mm / F30SC made with F30C and spacer with 2mm thickness

*: Centraggio maschio / Male centering diameter

CM	CM..F						CM..FB						CM..FL												
	a1	KA	KB	KC	KM	KN _{H8}	KO	KP	KQ	KA	KB	KC	KM	KN _{H8}	KO	KP	KQ	KA	KB	KC	KM	KN _{H8}	KO	KP	KQ
030	45°	54.5	6	4	68	50	6.5(n.4)	80	70	-	-	-	-	-	-	-	-	-	-	-	-	-	-	-	-
040	45°	67	7.5	4	80-95	60	9(n.4)	110	95	80	8.5	5	115-125	95	9.5(n.4)	140	112	97	7.5	4.5	80-95	60	9 (n.4)	110	95

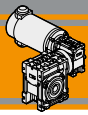

Accessori

Accessories

Albero lento semplice e doppio

Single and double output shaft

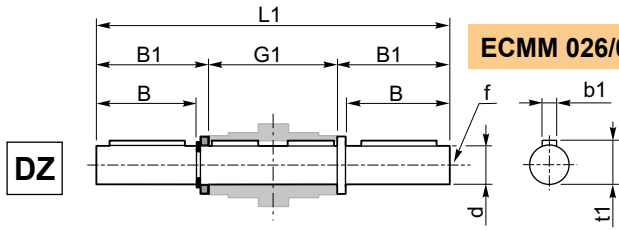

ECMM 026/030 - ECMM 030/040

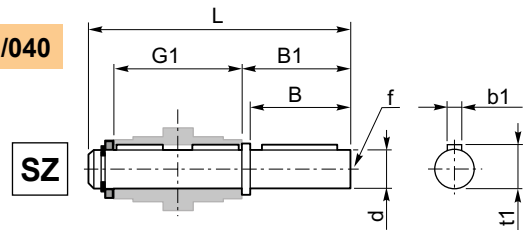

ECMM	d _{h7}	B	B1	G1	L	L1	f	b1	t1
026/030	14	30	32.5	63	102	128	M6	5	16
026/040 030/040	18	40	43	78	128	164	M6	6	20.5

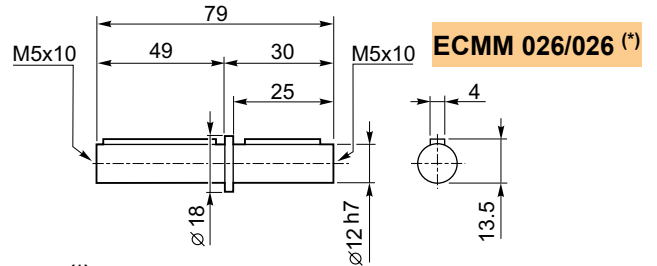

ECMM 026/026 (*)

(*)
Nota: disponibile solo per cavo uscita Ø12
Note: available for output hollow shaft Ø12 only

Braccio di reazione

Torque arm

ECMM	K1	G	KG	KH	R
026/030	85	14	23	8	15
026/040 030/040	100	14	31	10	18

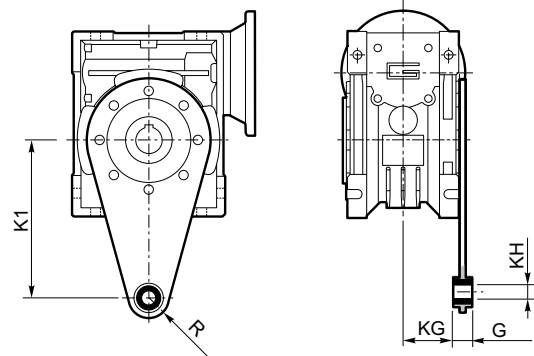

Opzioni

Options

VS1 - VS2 - Vite sporgente / Extended input shaft

SC - Safety cover

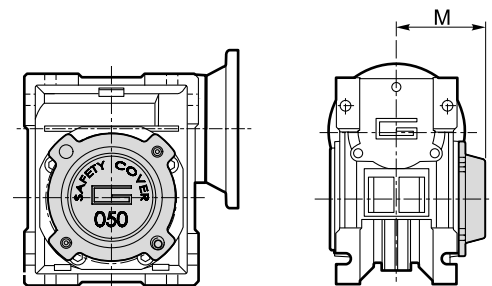
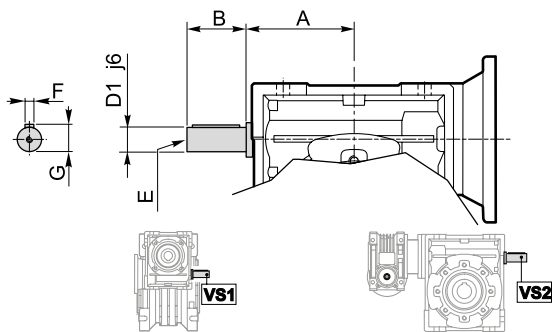

CMM	VS1						VS2					
	A	B	D ₁ j6	E	F	G	A	B	D ₁ j6	E	F	G
026/030	—	—	—	—	—	—	45	20	9	M4	3	10.2
026/040	—	—	—	—	—	—	53	23	11	M5	4	12.5
030/040	45	20	9	M4	3	10.2	53	23	11	M5	4	12.5

M	CM	
	30	40
	47	54.5

Costruito su richiesta
Built on request

MINI 
TECNO
small but strong

NDP
ECP

Motoriduttori CC epicicloidali
DC planetary gearmotors



MINI 
TECNO brand of
TRANSTECNO



DC

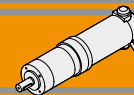

Indice	Index	Pag. Page
Caratteristiche tecniche	<i>Technical features</i>	BL2
Designazione	<i>Classification</i>	BL2
Versioni	<i>Versions</i>	BL2
Simbologia	<i>Symbols</i>	BL2
Lubrificazione	<i>Lubrication</i>	BL3
Carichi radiali	<i>Radial loads</i>	BL3
Rapporti	<i>Ratios</i>	BL3
Dati tecnici	<i>Technical data</i>	BL4
Motori applicabili	<i>IEC Motor adapters</i>	BL10
Dimensioni	<i>Dimensions</i>	BL11

Questa sezione annulla e sostituisce ogni precedente edizione o revisione. Qualora questa sezione non Vi sia giunta in distribuzione controllata, l'aggiornamento dei dati ivi contenuto non è assicurato. **In tal caso la versione più aggiornata è disponibile sul nostro sito internet www.transtecno.com**

This section replaces any previous edition and revision. If you obtained this catalogue other than through controlled distribution channels, the most up to date content is not guaranteed. In this case the latest version is available on our web site www.transtecno.com

Caratteristiche tecniche

Technical features

I motoriduttori CC epicicloidali a magneti permanenti in neodimio **NDP** e in ferrite **ECP** hanno le seguenti caratteristiche principali:

NDP neodymium permanent magnets and **ECP** ferrite permanent magnets DC planetary gearmotors range has the following main features:

- Alimentazione in bassa tensione 12/24 Vcc
- Possibilità di montaggio encoder e freno
- Potenze motore disponibili da 100 a 500W S2
- Entrata ed uscita coassiali
- Design compatto
- Lubrificazione permanente a grasso
- Possono essere installati in qualunque posizione di montaggio.
- Low voltage power supply 12/24 Vdc
- Suitable for encoder and brake assembly
- Motor power ratings available from 100 up to 500W S2
- In-line input and output
- Compact design
- Permanent grease oil long-life lubrication
- Can be intalled in all mounting position.

Designazione

Classification

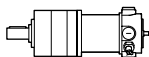
MOTORIDUTTORE / GEARMOTOR								
NDP	120/62		2	C	90	34.97	120	BR
Tipo Type	Grandezza Size		Stadi riduttore Gearbox stages	Versione riduttore Gearbox Version	Flangia uscita Output flange	Rapporto Ratio	Versione Motore Motor Version	Opzioni Options
NDP 	120/52 120/62	180/52 180/62	1 2 3	U C	80 90 105 120	Vedere tabella See tables	120 240	BR BRL

MOTORIDUTTORE / GEARMOTOR														
ECP	070/62							2	C	90	34.97	120	BR	
Tipo Type	Grandezza Size							Stadi riduttore Gearbox stages	Versione riduttore Gearbox Version	Flangia Uscita Output flange	Rapporto Ratio	Versione Motore Motor Version	Opzioni Options	
ECP 	020/42	035/42 035/52	050/42 050/52	070/52 070/62	100/52 100/62	180/52 180/62	250/62	350/62	1 2 3	U C	80 90 105 120	Vedere tabella See tables	120 240 24E	BR BRL

Versioni

Versions

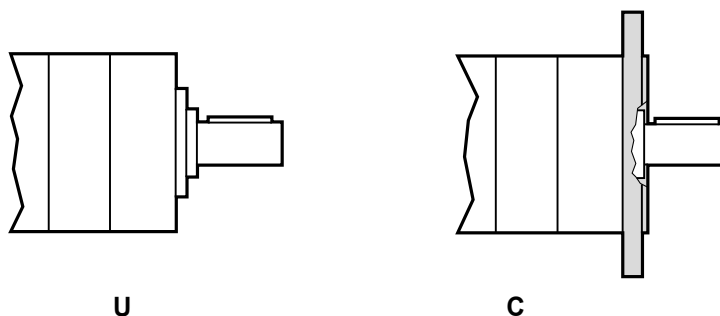

Simbologia

Symbols

n_1 [min ⁻¹]	Velocità in ingresso / Input speed	sf	Fattore di servizio / Service factor
n_2 [min ⁻¹]	Velocità in uscita / Output speed	Rd %	Rendimento dinamico / Dynamic efficiency
i	Rapporto di riduzione / Ratio	A ₂ [N]	Carico assiale ammissibile in uscita / Permitted output axial load
P ₁ [kW]	Potenza in entrata / Input power	R ₂ [N]	Carico radiale ammissibile in uscita / Permitted output radial load
M ₂ [Nm]	Coppia in uscita in funzione di P ₁ / Output torque referred to P ₁		

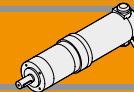
Lubrificazione
Lubrication

I riduttori epicicloidali sono lubrificati in modo permanente, non richiedono quindi ulteriore manutenzione. Questo gli consente di essere installati praticamente ovunque.

Planetary gearboxes are life-time lubricated with grease, therefore they are maintenance free. They can be installed in any location.

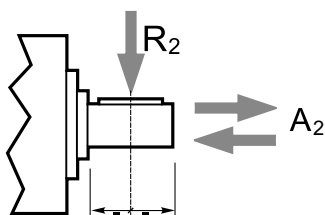
Carichi radiali
Radial loads

Numero di stadi Stages number	Carichi Radiali R_2 [N] / Radial Load R_2 [N]		
	P42	P52	P62
1	160	200	240
2	230	320	360
3	300	450	520

Numero di stadi Stages number	Carichi Assiali A_2 [N] / Axial Load A_2 [N]		
	P42	P52	P62
1	50	60	70
2	80	100	100
3	110	150	150

Rapporti
Ratios

Numero di stadi Stages number	Per tutte le grandezze di riduttori della serie P For all gearbox sizes of P range	
	Rapporti / Ratios	
1	3.70	
	4.28	
	5.18	
2	6.75	
	13.73	
	15.88	
	18.36	
	19.20	
	22.20	
	25.01	
	26.85	
	28.93	
	34.97	
3	45.56	
	50.89	
	58.85	
	68.06	
	71.16	
	78.71	
	92.70	
	95.17	
	99.50	
	107.20	
	115.07	
	123.97	
	129.62	
	139.13	
	149.90	
168.84		
181.24		
195.26		
236.09		
307.54		

Rapporti preferenziali per le taglie P42, P52, P62.
Preferred ratios for P42, P52, P62.

Disponibile a 4 stadi con rapporti fino a 2076
 Available 4 stages with ratio up to 2076

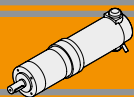

Dati tecnici per servizio S2

NDP

Technical data for S2 duty

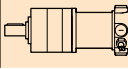
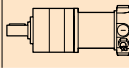
P_1 [W]	n_2 [min ⁻¹]	M_2 [Nm]	sf	i		Versione motore Motor version	P_1 [W]	n_2 [min ⁻¹]	M_2 [Nm]	sf	i		Versione motore Motor version		
160							160								
(3000 min ⁻¹)	811	2	2.6	3.70	NDP120/521	120/240	(3000 min ⁻¹)	59	18	2.8	50.89	NDP120/623	120/240		
	701	2	2.3	4.28			51	21	2.4	58.85					
	579	2	1.9	5.18			44	24	2.1	68.06					
	444	3	1.5	6.75			42	25	2.0	71.16					
	218	5	2.3	13.73			NDP120/522	120/240	38	28	1.8			78.71	
	189	6	2.0	15.88					32	33	1.5			92.70	
	163	7	1.7	18.36					32	34	1.5			95.17	
	156	7	1.6	19.20					30	36	1.4			99.50	
	135	8	1.4	22.20					28	38	1.3			107.20	
	120	10	1.3	25.01					26	41	1.2			115.07	
	112	10	1.2	26.85					24	44	1.1			123.97	
	104	11	1.1	28.93					23	46	1.1			129.62	
	86	13	0.9	34.97	22	50			1.0	139.13					
	66	17	0.7	45.56	20	54			0.9	149.90					
	59	18	1.4	50.89	NDP120/523	120/240			18	60	0.8	168.84			
	51	21	1.2	58.85					17	65	0.8	181.24			
	44	24	1.0	68.06			15	70	0.7	195.26					
	42	25	1.0	71.16			13	71	0.7	236.09					
	38	28	0.9	78.71			9.8	71	0.7	307.54					
	32	33	0.8	92.70											
	32	34	0.7	95.17											
	30	36	0.7	99.50											
	28	36	0.7	107.20											
	26	36	0.7	115.07											
	24	36	0.7	123.97											
	23	36	0.7	129.62											
	22	36	0.7	139.13											
	20	36	0.7	149.90											
	18	36	0.7	168.84											
	17	36	0.7	181.24											
	15	36	0.7	195.26											
	13	36	0.7	236.09											
	9.8	36	0.7	307.54											
	579	2	3.8	5.18	NDP120/621	120/240									
	444	3	2.9	6.75											
	218	5	4.8	13.73	NDP120/622	120/240									
	189	6	4.1	15.88											
	163	7	3.6	18.36											
	156	7	3.4	19.20											
	135	8	2.9	22.20											
	120	10	2.6	25.01											
	112	10	2.4	26.85											
	104	11	2.3	28.93											
	86	13	1.9	34.97											
	66	17	1.4	45.56											

NOTA
Per sf=0.7 verificare che la coppia utilizzata non ecceda il valore M2 indicato.

NOTE
For sf=0.7 check that the duty torque does not exceed the value M2

 Motoriduttori preferenziali / Preferred gearmotors

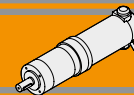
Dati tecnici per servizio S2
NDP
Technical data for S2 duty

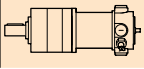
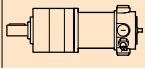
P_1 [W]	n_2 [min ⁻¹]	M_2 [Nm]	sf	i		Versione motore Motor version	P_1 [W]	n_2 [min ⁻¹]	M_2 [Nm]	sf	i		Versione motore Motor version	
250							250							
(3000 min ⁻¹)	59	28	0.9	50.89	NDP180/523	120/240	(3000 min ⁻¹)	59	28	1.8	50.89	NDP180/623	120/240	
	51	33	0.8	58.85				51	33	1.5	58.85			
	44	36	0.7	68.06				44	38	1.3	68.06			
	42	36	0.7	71.16				42	40	1.3	71.16			
	38	36	0.7	78.71				38	44	1.1	78.71			
	32	36	0.7	92.70				32	52	1.0	92.70			
	32	36	0.7	95.17				32	53	0.9	95.17			
	30	36	0.7	99.50				30	56	0.9	99.50			
	28	36	0.7	107.20				28	60	0.8	107.20			
	26	36	0.7	115.07				26	64	0.8	115.07			
	24	36	0.7	123.97				24	69	0.7	123.97			
	23	36	0.7	129.62				23	71	0.7	129.62			
	22	36	0.7	139.13				22	71	0.7	139.13			
	20	36	0.7	149.90				20	71	0.7	149.90			
	18	36	0.7	168.84				18	71	0.7	168.84			
	17	36	0.7	181.24				17	71	0.7	181.24			
	15	36	0.7	195.26				15	71	0.7	195.26			
	13	36	0.7	236.09				13	71	0.7	236.09			
	9.8	36	0.7	307.54				9.8	71	0.7	307.54			
	811	2	3.4	3.70			NDP180/621	120/240						
	701	3	2.9	4.28										
	579	3	2.4	5.18										
	444	4	1.9	6.75										
	218	8	3.0	13.73	NDP180/622	120/240								
	189	10	2.6	15.88										
	163	11	2.3	18.36										
	156	12	2.2	19.20										
	135	13	1.9	22.20										
	120	15	1.7	25.01										
	112	16	1.6	26.85										
	104	17	1.4	28.93										
	86	21	1.2	34.97										
	66	27	0.9	45.56										

NOTA

Per sf=0.7 verificare che la coppia utilizzata non ecceda il valore M2 indicato.

NOTE

For sf=0.7 check that the duty torque does not exceed the value M2

 Motoriduttori preferenziali / Preferred gearmotors

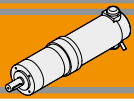

Dati tecnici per servizio S2

ECP

Technical data for S2 duty

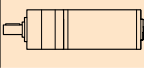
P_1 [W]	n_2 [min ⁻¹]	M_2 [Nm]	sf	i		Versione motore Motor version		
30								
(2850 min ⁻¹)	770	0.24	12.7	3.70	ECP020/421	120/24E		
	666	0.27	11.0	4.28				
	550	0.33	9.0	5.18				
	422	0.43	6.9	6.75				
	208	0.82	9.1	13.73	ECP020/422	120/24E		
	179	0.95	7.9	15.88				
	155	1.1	6.8	18.36				
	148	1.2	6.5	19.20				
	128	1.3	5.6	22.20				
	114	1.5	5.0	25.01				
	106	1.6	4.7	26.85				
	99	1.7	4.3	28.93				
	81	2.1	3.6	34.97				
	63	2.7	2.7	45.56				
	56	2.8	5.3	50.89			ECP020/423	120/24E
	48	3.3	4.6	58.85				
	42	3.8	3.9	68.06				
	40	4.0	3.8	71.16				
	36	4.4	3.4	78.71				
	31	5.2	2.9	92.70				
	30	5.3	2.8	95.17				
	29	5.6	2.7	99.50				
	27	6.0	2.5	107.20				
	25	6.4	2.3	115.07				
	23	6.9	2.2	123.97				
	22	7.3	2.1	129.62				
	20	7.8	1.9	139.13				
	19	8.4	1.8	149.90				
	17	9.5	1.6	168.84				
	16	10	1.5	181.24				
	15	11	1.4	195.26				
	12	13	1.1	236.09				
	9.3	17	0.9	307.54				

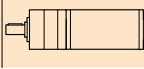
P_1 [W]	n_2 [min ⁻¹]	M_2 [Nm]	sf	i		Versione motore Motor version		
55								
(2850 min ⁻¹)	31	12	1.3	95.17	ECP035/423	120/240		
	30	13	1.2	99.50				
	28	14	1.1	107.20				
	26	14	1.0	115.07				
	24	16	1.0	123.97				
	23	16	0.9	129.62				
	22	18	0.9	139.13				
	20	19	0.8	149.90				
	18	21	0.7	168.84				
	17	21	0.7	181.24				
	15	21	0.7	195.26				
	13	21	0.7	236.09				
	10	21	0.7	307.54				
	811	0.53	7.5	3.70			ECP035/521	120/240
	701	0.62	6.5	4.28				
	579	0.75	5.4	5.18				
	444	0.97	4.1	6.75				
	218	1.9	6.5	13.73			ECP035/522	120/240
	189	2.1	5.6	15.88				
	163	2.5	4.8	18.36				
	156	2.6	4.6	19.20				
	135	3.0	4.0	22.20				
	120	3.4	3.6	25.01				
	112	3.6	3.3	26.85				
	104	3.9	3.1	28.93				
	86	4.7	2.5	34.97				
	66	6.2	2.0	45.56				
	59	6.4	3.9	50.89	ECP035/523	120/240		
	51	7.4	3.4	58.85				
	44	8.6	2.9	68.06				
	42	9.0	2.8	71.16				
	38	9.9	2.5	78.71				
	32	11.7	2.1	92.70				
	31	12.0	2.1	95.17				
	30	12.5	2.0	99.50				
	28	13.5	1.9	107.20				
	26	14.5	1.7	115.07				
	24	15.6	1.6	123.97				
	23	16.3	1.5	129.62				
	22	17.5	1.4	139.13				
	20	18.9	1.3	149.90				
	18	21.3	1.2	168.84				
	17	22.8	1.1	181.24				
	15	24.6	1.0	195.26				
	13	29.7	0.8	236.09				
	10	35.7	0.7	307.54				

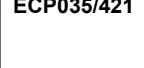
P_1 [W]	n_2 [min ⁻¹]	M_2 [Nm]	sf	i		Versione motore Motor version
55						
(3000 min ⁻¹)	811	0.53	5.6	3.70	ECP035/421	120/240
	701	0.62	4.9	4.28		
	579	0.75	4.0	5.18		
	444	0.97	3.1	6.75		
	218	1.9	4.0	13.73	ECP035/422	120/240
	189	2.1	3.5	15.88		
	163	2.5	3.0	18.36		
	156	2.6	2.9	19.20		
	135	3.0	2.5	22.20		
	120	3.4	2.2	25.01		
	112	3.6	2.1	26.85		
	104	3.9	1.9	28.93		
	86	4.7	1.6	34.97		
	65.8	6.2	1.2	45.56		
	59	6.4	2.3	50.89		
	51	7.4	2.0	58.85		
	44	8.6	1.7	68.06		
	42	9.0	1.7	71.16		
	38	9.9	1.5	78.71		
	32	12	1.3	92.70		

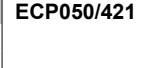
P_1 [W]	n_2 [min ⁻¹]	M_2 [Nm]	sf	i		Versione motore Motor version
70						
(3000 min ⁻¹)	811	0.65	4.6	3.70	ECP050/421	12E/24E
	701	0.75	4.0	4.28		
	579	0.91	3.3	5.18		
	444	1.2	2.5	6.75		
	218	2.3	3.3	13.73	ECP050/422	12E/24E
	189	2.6	2.9	15.88		
	163	3.0	2.5	18.36		
	156	3.2	2.4	19.20		
	135	3.7	2.0	22.20		
	120	4.1	1.8	25.01		
	112	4.4	1.7	26.85		
	104	4.8	1.6	28.93		
	86	5.8	1.3	34.97		
	66	7.5	1.0	45.56		

NOTA
Per sf=0.7 verificare che la coppia utilizzata non
ecceda il valore M2 indicato.

NOTE
For sf=0.7 check that the duty torque does not
exceed the value M2

 Motoriduttori preferenziali / Preferred gearmotors

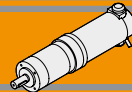
Dati tecnici per servizio S2
ECP
Technical data for S2 duty

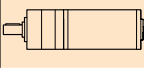
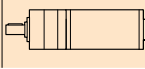
P_1 [W]	n_2 [min ⁻¹]	M_2 [Nm]	sf	i		Versione motore Motor version	P_1 [W]	n_2 [min ⁻¹]	M_2 [Nm]	sf	i		Versione motore Motor version					
70							100											
(2850 min ⁻¹)	59	7.8	1.9	50.89	ECP050/423	12E/24E	(3000 min ⁻¹)	811	0.92	4.4	3.70	ECP070/521	120/240					
	51	9.1	1.7	58.85					701	1.1	3.8			4.28				
	44	10	1.4	68.06					579	1.3	3.1			5.18				
	42	11	1.4	71.16					444	1.7	2.4			6.75				
	38	12	1.2	78.71														
	32	14	1.1	92.70					218	3.2	3.8			13.73	ECP070/522	120/240		
	31	15	1.0	95.17					189	3.7	3.3			15.88				
	30	15	1.0	99.50					163	4.3	2.8			18.36				
	28	17	0.9	107.20					156	4.5	2.7			19.20				
	26	18	0.8	115.07					135	5.2	2.3			22.20				
	24	19	0.8	123.97					120	5.8	2.1			25.01				
	23	20	0.8	129.62					112	6.2	1.9			26.85				
	22	21	0.7	139.13					104	6.7	1.8			28.93				
	20	21	0.7	149.90					86	8.1	1.5			34.97				
	18	21	0.7	168.84					66	11	1.1			45.56				
	17	21	0.7	181.24														
	15	21	0.7	195.26					59	11	2.3			50.89	ECP070/523	120/240		
	13	21	0.7	236.09					51	13	2.0			58.85				
	9.8	21	0.7	307.54			44	15	1.7	68.06								
							42	15	1.6	71.16								
	163	3.0	4.0	18.36	ECP050/522	12E/24E	38	17	1.5	78.71								
	156	3.2	3.8	19.20					32	20	1.2	92.70						
	135	3.7	3.3	22.20					31	21	1.2	95.17						
	120	4.1	2.9	25.01					30	22	1.2	99.50						
	112	4.4	2.7	26.85					28	23	1.1	107.20						
	104	4.8	2.5	28.93					26	25	1.0	115.07						
	86	5.8	2.1	34.97					24	27	0.9	123.97						
	66	7.5	1.6	45.56					23	28	0.9	129.62						
									22	30	0.8	139.13						
	59	7.8	3.2	50.89			ECP050/523	12E/24E	20	33	0.8	149.90						
	51	9.1	2.8	58.85					18	36	0.7	168.84						
	44	10	2.4	68.06					17	36	0.7	181.24						
	42	11	2.3	71.16					15	36	0.7	195.26						
	38	12	2.1	78.71					13	36	0.7	236.09						
	32	14	1.8	92.70					9.8	36	0.7	307.54						
	31	15	1.7	95.17														
	30	15	1.6	99.50					120.0	5.8	4.3	25.01	ECP070/622	120/240				
	28	17	1.5	107.20					112	6.2	4.0	26.85						
	26	18	1.4	115.07					104	6.7	3.7	28.93						
	24	19	1.3	123.97					86	8.1	3.1	34.97						
	23	20	1.3	129.62					66	11	2.4	45.56						
	22	21	1.2	139.13														
	20	23	1.1	149.90					59	11	4.5	50.89			ECP070/623	120/240		
	18	26	1.0	168.84					51	13	3.9	58.85						
	17	28	0.9	181.24					44	15	3.4	68.06						
	15	30	0.8	195.26					42	15	3.2	71.16						
	13	36	0.7	236.09					38	17	2.9	78.71						
	9.8	36	0.7	307.54			32	20	2.5	92.70								
							31	21	2.4	95.17								
							30	22	2.3	99.50								
							28	23	2.1	107.20								
							26	25	2.0	115.07								
							24	27	1.9	123.97								
							23	28	1.8	129.62								
							22	30	1.7	139.13								
							20	33	1.5	149.90								
							18	37	1.4	168.84								
							17	39	1.3	181.24								
							15	42	1.2	195.26								
							13	51	1.0	236.09								
							9.8	67	0.7	307.54								

NOTA

Per sf=0.7 verificare che la coppia utilizzata non ecceda il valore M2 indicato.

NOTE

For sf=0.7 check that the duty torque does not exceed the value M2

Motoriduttori preferenziali / Preferred gearmotors

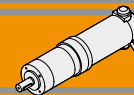
Dati tecnici per servizio S2
ECP
Technical data for S2 duty

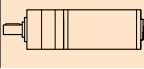
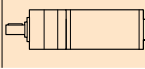
P_1 [W]	n_2 [min ⁻¹]	M_2 [Nm]	sf	i		Versione motore Motor version	P_1 [W]	n_2 [min ⁻¹]	M_2 [Nm]	sf	i		Versione motore Motor version					
250							350											
(3000 min ⁻¹)	811	2.4	3.4	3.70	ECP180/621	120/240/24E	(3000 min ⁻¹)	59	39.9	1.3	50.89	ECP250/623	120/240					
	701	2.7	2.9	4.28					51	46.1	1.1			58.85				
	579	3.3	2.4	5.18					44	53.4	0.9			68.06				
	444	4.3	1.9	6.75					42	55.8	0.9			71.16				
	218	8.2	3.0	13.73			ECP180/622	120/240/24E	38	61.7	0.8			78.71				
	189	9.5	2.6	15.88							32			72.7	0.7	92.70		
	163	11	2.3	18.36							32			74.6	0.7	95.17		
	156	12	2.2	19.20							30			71.0	0.7	99.50		
	135	13	1.9	22.20							28			71.0	0.7	107.20		
	120	15	1.7	25.01							26			71.0	0.7	115.07		
	112	16	1.6	26.85					24	71.0	0.7	123.97						
	104	17	1.4	28.93					23	71.0	0.7	129.62						
	86	21	1.2	34.97					22	71.0	0.7	139.13						
	66	27	0.9	45.56					20	71.0	0.7	149.90						
	59	28	1.8	50.89	ECP180/623	120/240/24E	18	71.0	0.7	168.84								
	51	33	1.5	58.85					17	71.0	0.7	181.24						
	44	38	1.3	68.06					15	71.0	0.7	195.26						
	42	40	1.3	71.16					13	71.0	0.7	236.09						
	38	44	1.1	78.71					9.8	71.0	0.7	307.54						
	32	52	1.0	92.70														
	31	53	0.9	95.17														
	30	56	0.9	99.50														
	28	60	0.8	107.20														
	26	64	0.8	115.07														
	24	69	0.7	123.97														
	23	71	0.7	129.62														
	22	71	0.7	139.13														
	20	71	0.7	149.90														
	18	71	0.7	168.84														
	17	71	0.7	181.24														
	15	71	0.7	195.26														
	13	71	0.7	236.09														
	9.8	71	0.7	307.54														
350							500											
(3000 min ⁻¹)	811	3.3	2.4	3.70	ECP250/621	120/240	(3000 min ⁻¹)	811	4.6	1.7	3.70	ECP350/621	120/240					
	701	3.8	2.1	4.28					701	5.4	1.5			4.28				
	579	4.6	1.7	5.18					579	6.5	1.2			5.18				
	444	6.0	1.3	6.75					444	8.5	0.9			6.75				
	218	11.5	2.2	13.73	ECP250/622	120/240	218	16	1.5	13.73	ECP350/622	120/240						
	189	13.3	1.9	15.88					189	19			1.3	15.88				
	163	15.4	1.6	18.36					163	22			1.2	18.36				
	156	16.1	1.6	19.20					156	23			1.1	19.20				
	135	18.6	1.3	22.20					135	26			1.0	22.20				
	120	21.0	1.2	25.01					120	29			0.8	25.01				
	112	22.6	1.1	26.85					112	32			0.8	26.85				
	104	24.3	1.0	28.93					104	34			0.7	28.93				
	86	29.4	0.9	34.97					86	36			0.7	34.97				
	66	38.3	0.7	45.56					66	36			0.7	45.56				
	59	56	0.9	50.89	ECP350/623	120/240	59	56	0.9	50.89								
	51	65	0.8	58.85					51	65	0.8	58.85						
	44	71	0.7	68.06					44	71	0.7	68.06						
	42	71	0.7	71.16					42	71	0.7	71.16						
	38	71	0.7	78.71					38	71	0.7	78.71						
	32	71	0.7	92.70					32	71	0.7	92.70						
	31	71	0.7	95.17					31	71	0.7	95.17						
	30	71	0.7	99.50					30	71	0.7	99.50						
	28	71	0.7	107.20					28	71	0.7	107.20						
	26	71	0.7	115.07					26	71	0.7	115.07						
	24	71	0.7	123.97			24	71	0.7	123.97								
	23	71	0.7	129.62			23	71	0.7	129.62								
	22	71	0.7	139.13			22	71	0.7	139.13								
	20	71	0.7	149.90			20	71	0.7	149.90								
	18	71	0.7	168.84			18	71	0.7	168.84								
	17	71	0.7	181.24			17	71	0.7	181.24								
	15	71	0.7	195.26			15	71	0.7	195.26								
	13	71	0.7	236.09			13	71	0.7	236.09								
	9.8	71	0.7	307.54			9.8	71	0.7	307.54								

NOTA

Per sf=0.7 verificare che la coppia utilizzata non ecceda il valore M2 indicato.

NOTE

For sf=0.7 check that the duty torque does not exceed the value M2

Motoriduttori preferenziali / Preferred gearmotors

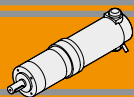

NDP
ECP

Motoriduttori CC epicicloidali
DC planetary gearmotors



Motori applicabili

Motor adapters

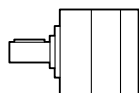
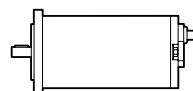
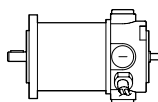

		ND		EC								
		120.120 120.240	180.120 180.240	020.120 020.24E	035.120 035.240	050.12E 050.24E	070.120 070.240	100.120 100.240 100.24E	180.120 180.240	180.24E	250.120 250.240	350.120 350.240
P	42						*	*	*			
	52											
	62											



Combinazioni preferenziali / Preferred combinations

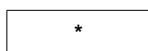

* Contattare il nostro servizio tecnico / Please contact our technical department

Dimensioni

Dimensions

NDP120/... U

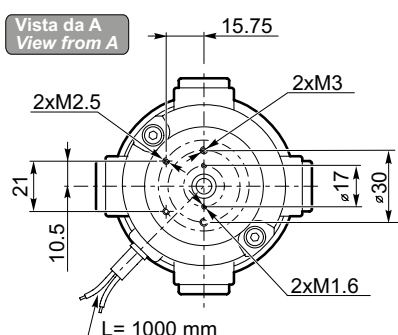
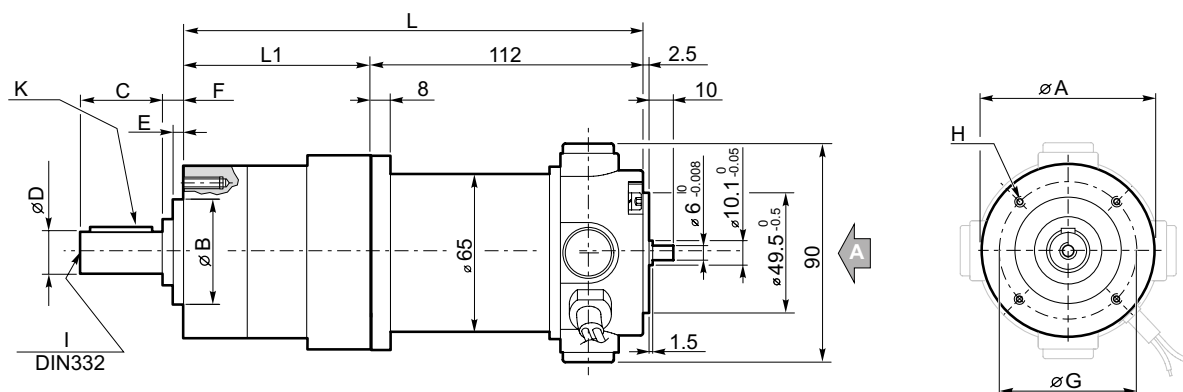

Freno / Brake → BA9

Encoder → BA9

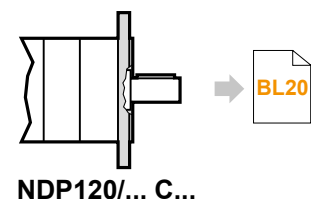

Tipo Type	Numero di stadi Stages number	Dimensioni / Dimensions											
		L1	L	A	B	C	D	E	F	G	H	I	K
NDP120/52...	1	74	186	52	32 h8	20.8	12 h7	3	4.2	40	M5x10	M4x10	4x4x16
	2	88	200										
	3	102	214										
NDP120/62...	1	74	186	62	40 j7	30	14 h7	5	9	52	M5x10	M5x12	5x5x18
	2	90	202										
	3	106	218										

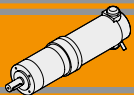

Dimensioni

Dimensions

NDP180/... U

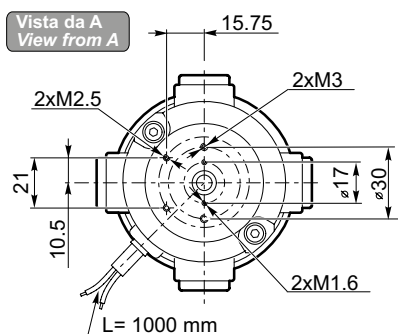
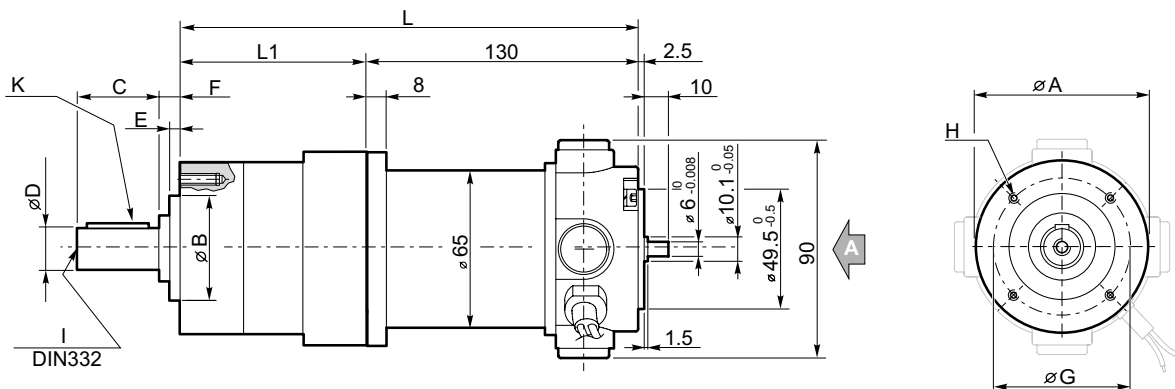

- Freno / Brake → BA9
- Encoder → BA9

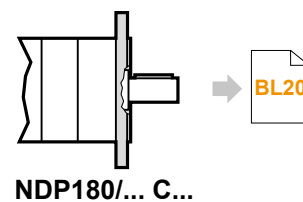

Tipo Type	Numero di stadi Stages number	Dimensioni / Dimensions											
		L1	L	A	B	C	D	E	F	G	H	I	K
NDP180/52	1	74	204	52	32 h8	20.8	12 h7	3	4.2	40	M5x10	M4x10	4x4x16
	2	88	218										
	3	102	232										
NDP180/62	1	74	204	62	40 j7	30	14 h7	5	9	52	M5x10	M5x12	5x5x18
	2	90	220										
	3	106	236										

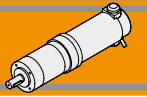

Dimensioni

Dimensions

ECP020/42... U

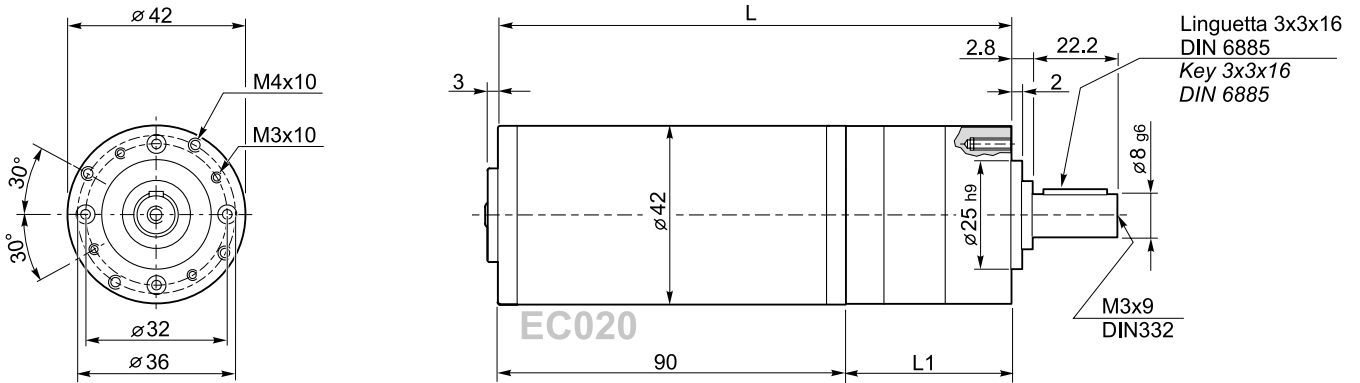

Encoder BB24

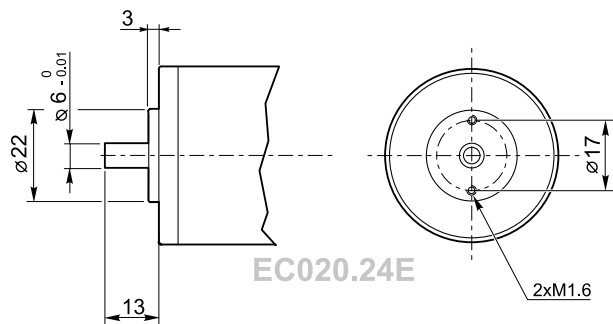

	Numero di stadi / Stages number		
ECP020/42...	1	2	3
L1	60	73	86
L	150	163	176

ECP035/... U

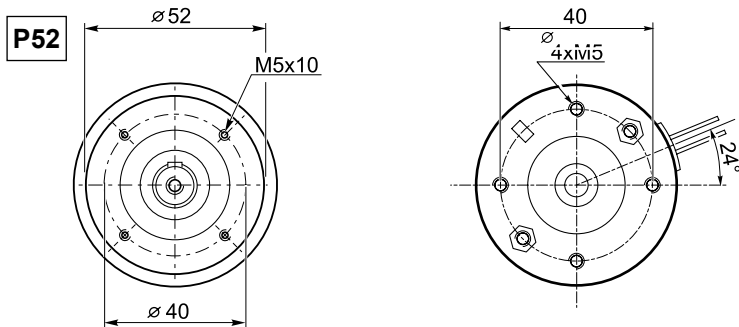
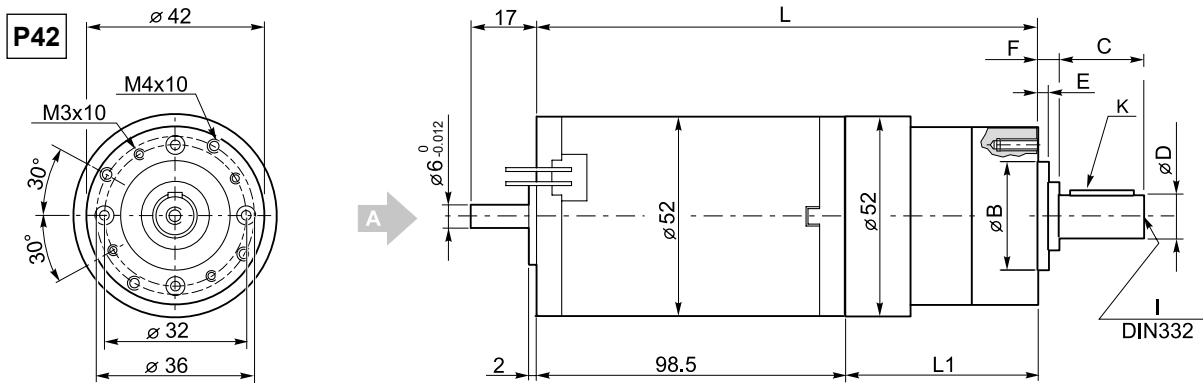

Tipo Type	Numero di stadi Stages number	Dimensioni / Dimensions								
		L1	L	B	C	D	E	F	I	K
ECP035/42...	1	60	158.5	25 h9	22.2	8 g6	2	2.8	M3x9	3x3x16
	2	73	171.5							
	3	86	184.5							
ECP035/52...	1	72.5	175.5	32 h8	20.8	12 h7	3	4.2	M4x10	4x4x16
	2	86.5	189.5							
	3	100.5	203.5							

DC

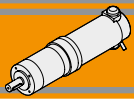

Dimensioni

Dimensions

ECP050/... U

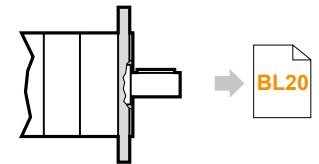
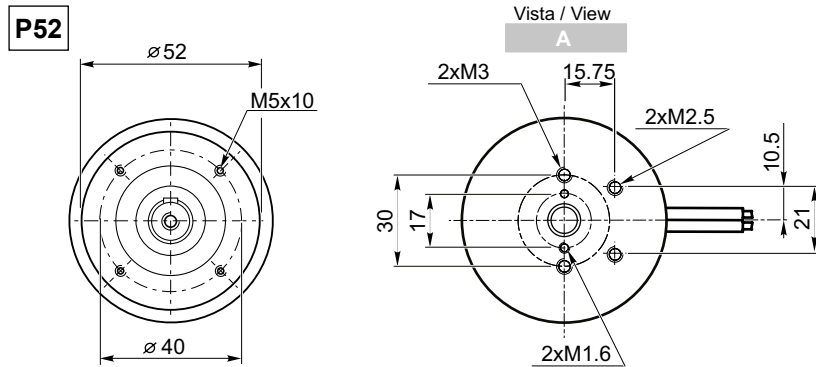
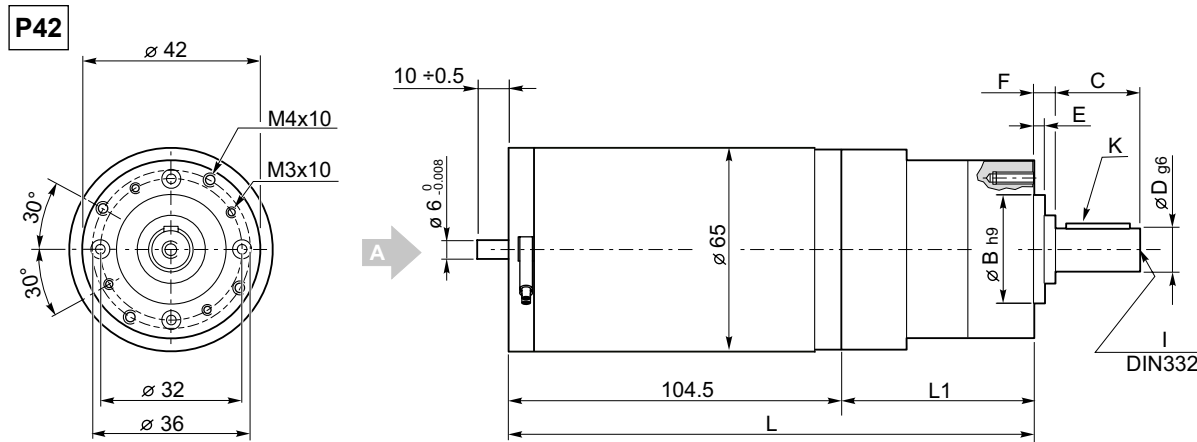

ECP050/... C...



Tipo Type	Numero di stadi Stages number	Dimensioni / Dimensions								
		L1	L	B	C	D	E	F	I	K
ECP050/42...	1	60	164.5	25 h9	22.2	8 g6	2	2.8	M3x9	3x3x16
	2	73	177.5							
	3	86	190.5							
ECP050/52...	1	72.5	177	32 h8	20.8	12 h7	3	4.2	M4x10	4x4x16
	2	86.5	191							
	3	100.5	205							

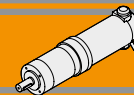
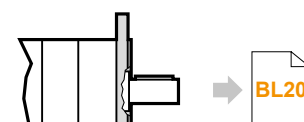
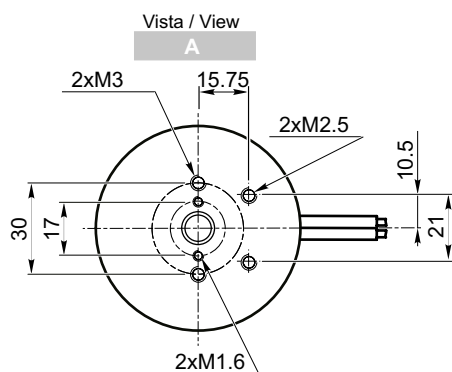
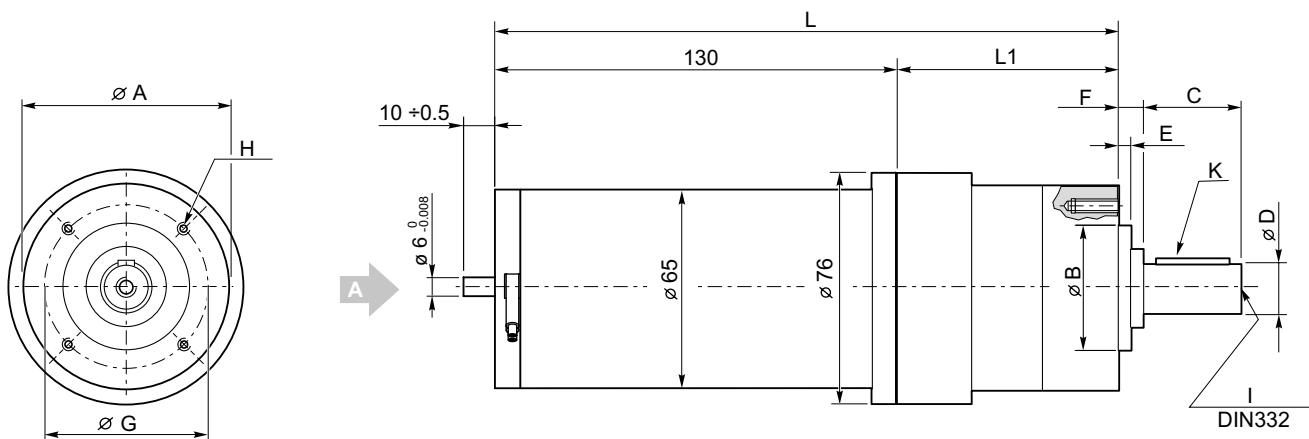

Dimensioni
Dimensions
ECP070/... U

ECP070/... C...

Motori / Motors IP66

Freno / Brake

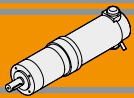
Encoder

Tipo Type	Numero di stadi Stages number	Dimensioni / Dimensions											
		L1	L	A	B	C	D	E	F	G	H	I	K
ECP070/52...	1	74	204	52	32 h8	20.8	12 h7	3	4.2	40	M5x10	M4x10	4x4x16
	2	88	218										
	3	102	232										
ECP070/62...	1	74	204	62	40 j7	30	14 h7	5	9	52	M5x10	M5x12	5x5x18
	2	90	220										
	3	106	236										



Dimensioni

Dimensions

ECP100/... U... 120/140

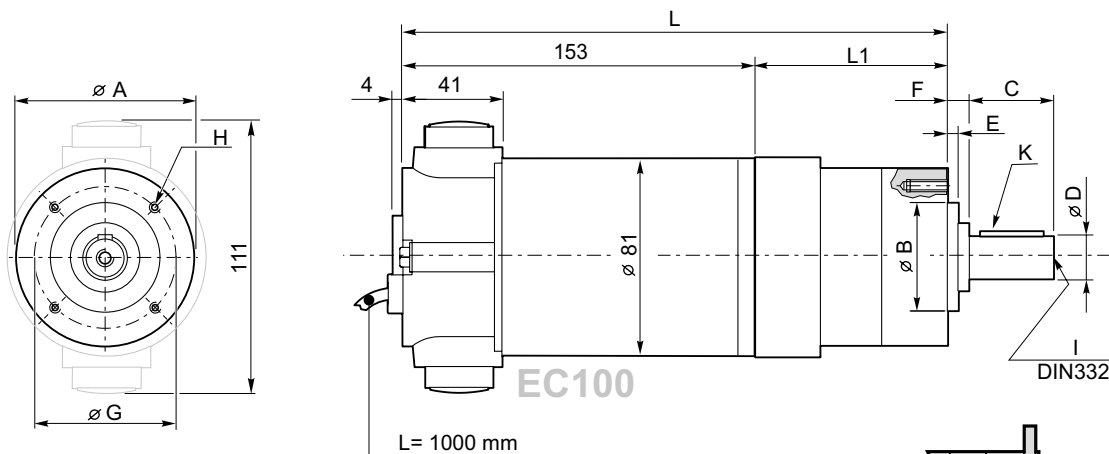

ECP100/... U... 24E

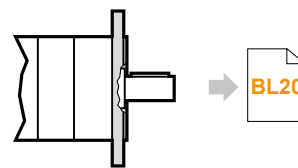
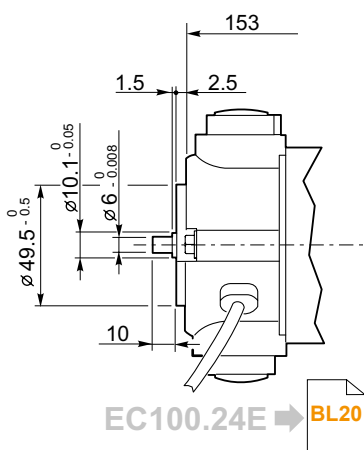

ECP100/... C...

Motori / Motors IP66 \rightarrow **BC4**

Freno / Brake \rightarrow **BB23**

Encoder \rightarrow **BB24**

Tipo Type	Numero di stadi Stages number	Dimensioni / Dimensions											
		L1	L	A	B	C	D	E	F	G	H	I	K
ECP100/52...	1	74	227	52	32 h8	20.8	12 h7	3	4.2	40	M5x10	M4x10	4x4x16
	2	88	241										
	3	102	255										
ECP100/62...	1	74	227	62	40 j7	30	14 h7	5	9	52	M5x10	M5x12	5x5x18
	2	90	243										
	3	106	259										

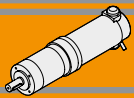

Dimensioni

Dimensions

ECP250/... U

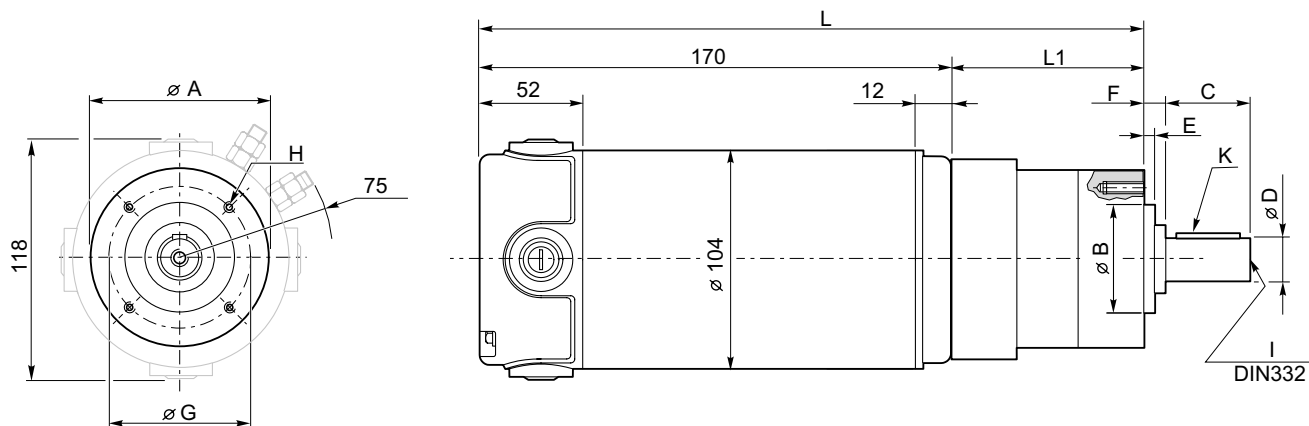

Motori / Motors IP66



BC8

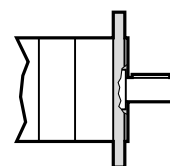

ECP250/... C...



BL20

Tipo Type	Numero di stadi Stages number	Dimensioni / Dimensions											
		L1	L	A	B	C	D	E	F	G	H	I	K
ECP250/62...	1	76	246	62	40 j7	30	14 h7	5	9	52	M5x10	M5x12	5x5x18
	2	92	262										
	3	108	278										

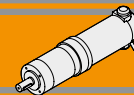

Dimensioni

Dimensions

ECP350/... U

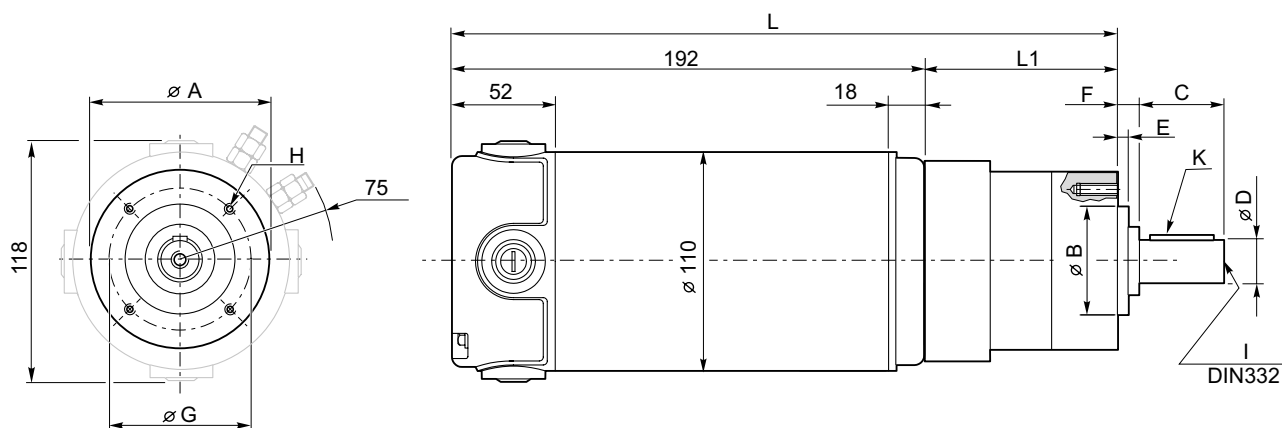

Motori / Motors IP66



Freno / Brake

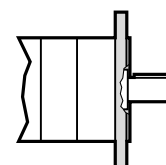

ECP350/... C...

Tipo Type	Numero di stadi Stages number	Dimensioni / Dimensions											
		L1	L	A	B	C	D	E	F	G	H	I	K
ECP350/62...	1	76	268	62	40 j7	30	14 h7	5	9	52	M5x10	M5x12	5x5x18
	2	92	284										
	3	108	300										

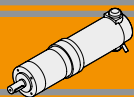

Dimensioni

Dimensions

ECP100.24E
ECP180.24E

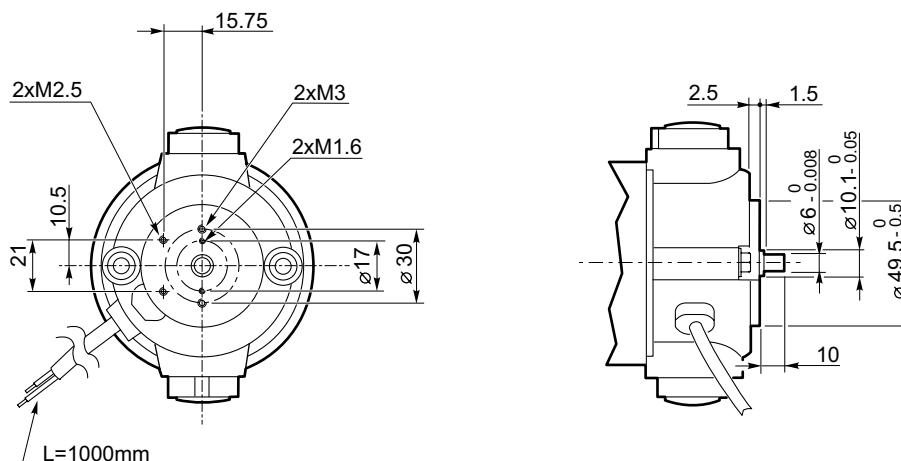

NDP.../... C... - ECP.../... C... Flange uscita / Output flanges

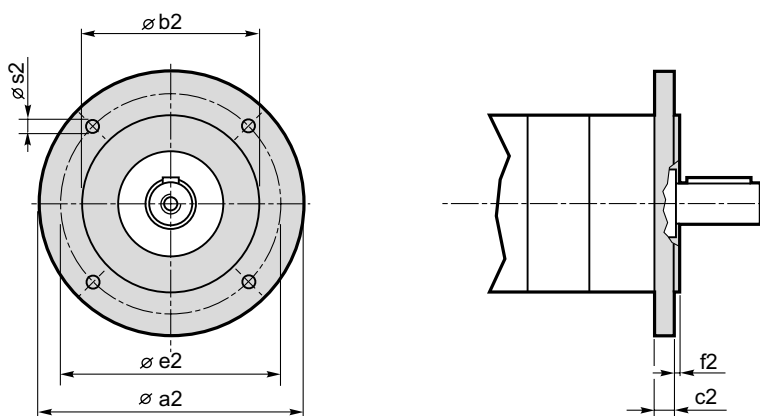

Dimensioni / Dimensions							
P	a2	b2	c2	e2	f2	s2	Flangia uscita Output flange
52	80	50 j7	9	65	2.5	M5	C80
	90	60 j7	9	75	2.5	5.5	C90
	105	70 j7	9	85	2.5	6.5	C105
	120	80 j7	9	100	3.0	6.5	C120
62	80	50 j7	9	65	2.5	M5	C80
	90	60 j7	9	75	2.5	5.5	C90
	105	70 j7	9	85	2.5	6.5	C105
	120	80 j7	9	100	3.0	6.5	C120

MINI  **TECNO**
small but strong

NDWMP
ECWMP

Motoriduttori CC combinati
DC double reduction gearmotors



MINI  **TECNO** brand of
TRANSTECNO[®]



DC

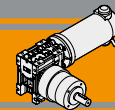

Indice	Index	Pag. Page
Caratteristiche tecniche	<i>Technical features</i>	BM2
Designazione	<i>Classification</i>	BM2
Versioni	<i>Versions</i>	BM2
Simbologia	<i>Symbols</i>	BM2
Lubrificazione	<i>Lubrication</i>	BM3
Carichi radiali	<i>Radial loads</i>	BM3
Rapporti	<i>Ratios</i>	BM3
Dati tecnici	<i>Technical data</i>	BM4
Dimensioni	<i>Dimensions</i>	BM6

Questa sezione annulla e sostituisce ogni precedente edizione o revisione. Qualora questa sezione non Vi sia giunta in distribuzione controllata, l'aggiornamento dei dati ivi contenuto non è assicurato. **In tal caso la versione più aggiornata è disponibile sul nostro sito internet www.transtecno.com**

This section replaces any previous edition and revision. If you obtained this catalogue other than through controlled distribution channels, the most up to date content is not guaranteed. In this case the latest version is available on our web site www.transtecno.com

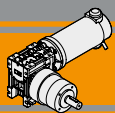

Caratteristiche tecniche

Technical features

L'accoppiamento di un riduttore a vite senza fine con un riduttore epicicloidale consente di ottenere elevati rapporti di riduzione ($i_{max} = 1/18452$) e di disporre di un gruppo autolubrificato compatto, silenzioso e con un'elevata affidabilità.

The coupling of a wormgearbox to a planetary gearbox allows to obtain high reduction ratios ($i_{max} = 1/18452$) and to get a compact, silent, self lubricated with high reliability group.

Designazione

Classification

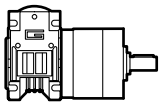
MOTORIDUTTORE / GEARMOTOR								
NDWMP	120/026/52		2	CD	90	405	240	BR
Tipo Type	Grandezza Size		Numero stadi epicicloidale Planetary stages number	Versione Riduttore Gearbox Version	Flangia Uscita Output flange	Rapporto Ratio	Versione Motore Motor Version	Opzioni Options
	120/026/52 120/026/62	180/026/62	1	US	80	Vedere tabella See tables	120 240	BR BRL
			2	UD	90			
			3	CS	105			
				CD	120			

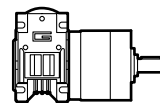
MOTORIDUTTORE / GEARMOTOR									
ECWMP	070/026/52			2	CD	90	405	240	BR
Tipo Type	Grandezza Size			Numero stadi epicicloidale Planetary stages number	Versione Riduttore Gearbox Version	Flangia Uscita Output flange	Rapporto Ratio	Versione Motore Motor Version	Opzioni Options
	070/026/52 070/026/62	100/026/52 100/026/62	180/026/62	1	US	80	Vedere tabella See tables	120 240 24E	BR BRL
				2	UD	90			
				3	CS	105			
					CD	120			

Versioni

Versions

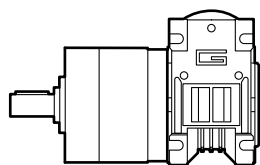

US

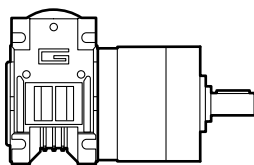

UD

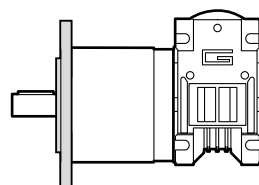

CS

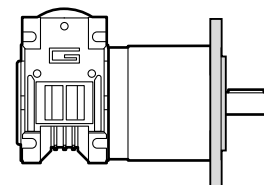

CD

Simbologia

Symbols

- n_1 [min^{-1}] Velocità in ingresso / *Input speed*
- n_2 [min^{-1}] Velocità in uscita / *Output speed*
- i Rapporto di riduzione / *Ratio*
- P_1 [kW] Potenza in entrata / *Input power*
- M_n [Nm] Coppia nominale in uscita del riduttore / *Maximum output torque of the gearbox*
- M_2 [Nm] Coppia in uscita in funzione di P_1 / *Output torque referred to P_1*
- sf Fattore di servizio / *Service factor*
- Rd % Rendimento dinamico / *Dynamic efficiency*
- A_2 [N] Carico assiale ammissibile in uscita / *Permitted output axial load*
- R_2 [N] Carico radiale ammissibile in uscita / *Permitted output radial load*

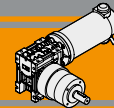

Lubrificazione

Lubrication

I riduttori a vite senza fine della serie CM sono lubrificati a vita con olio sintetico di viscosità 320 e possono essere installati in qualunque posizione di montaggio.

Permanent synthetic oil long-life lubrication allow to use CM wormgearbox range in all mounting position.

I riduttori epicicloidali sono lubrificati in modo permanente, non richiedono quindi ulteriore manutenzione. Questo gli consente di essere installati praticamente ovunque.

Planetary gearboxes are life-time lubricated with grease, therefore they are maintenance free. They can be installed in any location.

Carichi radiali

Radial loads

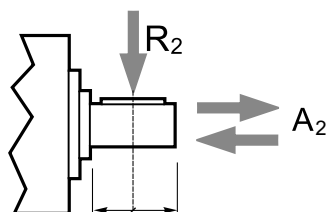

Numero di stadi Stages number	Carichi Radiali R_2 [N] Radial Load R_2 [N]		
	P52	P62	P81
1	200	240	400
2	320	360	600
3	450	520	1000

Numero di stadi Stages number	Carichi Assiali A_2 [N] Axial Load A_2 [N]		
	P52	P62	P81
1	60	70	80
2	100	100	120
3	150	150	200

Rapporti

Ratios

Motoriduttore Gearmotor	Numero stadi epicicloidale Planetary stages number	Rapporto epicicloidale Planetary ratio	Rapporto vite senza fine Wormgearbox ratio	Rapporto finale Total ratio
.../026/052 .../026/062	1	6.75	10	67.5
			15	101.3
			20	135
			30	202.5
			40	270
			50	337.5
	2	25.01	10	250.1
			15	375.15
			20	500.2
			30	750.3
			40	1000.4
			50	1250.5
		45.56		60

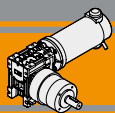

Dati tecnici per servizio S2

NDWMP

Technical data for S2 duty

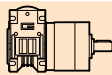
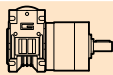
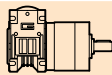
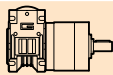
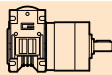
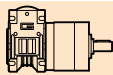
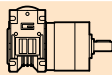
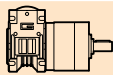
P_1 [W]	n_2 [min ⁻¹]	M_2 [Nm]	sf	i		Versione motore Motor version	P_1 [W]	n_2 [min ⁻¹]	M_2 [Nm]	sf	i		Versione motore Motor version											
160							250																	
(3000 min ⁻¹)	44.4	22.8	1.1	67.5		120/026/521	120/240	(3000 min ⁻¹)	44.4	25.0	1.0	67.5		180/026/521	120/240									
	29.6	25.0	1.0	101.3																				
	22.2	25.0	1.0	135																				
	14.8	25.0	1.0	202.5																				
	11.1	25.0	1.0	270																				
	8.9	25.0	1.0	337.5																				
	7.4	25.0	1.0	405																				
	12.0	25.0	1.0	250.1					120/026/522	120/240		44.4				35.7	1.1	67.5		180/026/621	120/240			
	8.0	25.0	1.0	375.15																				
	6.0	25.0	1.0	500.2																				
	4.0	25.0	1.0	750.3																				
	3.0	25.0	1.0	1000.4																				
	2.4	25.0	1.0	1250.5																				
	2.0	25.0	1.0	1500.6																				
	1.1	25.0	1.0	2734																				
	44.4	23	1.7	67.5		120/026/621	120/240					29.6	40.0	1.0	101.3		180/026/622	120/240						
	29.6	34	1.2	101.3																				
	22.2	40	1.0	135.0																				
	14.8	40	1.0	202.5																				
	11.1	40	1.0	270.0																				
	8.9	40	1.0	337.5																				
	7.4	40	1.0	405.0																				
	12.0	50.0	1.0	250.1																				
	8.0	50.0	1.0	375.15																				
	6.0	50.0	1.0	500.2																				
	4.0	50.0	1.0	750.3																				
	3.0	50.0	1.0	1000.4																				
	2.4	50.0	1.0	1250.5																				
	2.0	50.0	1.0	1500.6																				
	1.1	50.0	1.0	2734																				

Nota: Verificare sempre che la coppia M_2 utilizzata non ecceda il valore indicato nelle caselle in grigio

Note: Please check that the output torque M_2 does not exceed the value into the grey areas

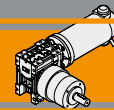

Dati tecnici per servizio S2

ECWMP

Technical data for S2 duty

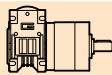
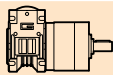
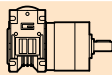
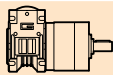
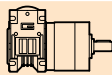
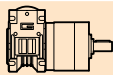
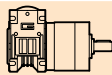
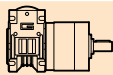
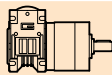
P_1 [W]	n_2 [min ⁻¹]	M_2 [Nm]	sf	i		Versione motore Motor version	P_1 [W]	n_2 [min ⁻¹]	M_2 [Nm]	sf	i		Versione motore Motor version				
100							140										
(3000 min ⁻¹)	44.4	14	1.8	67.5		070/026/521	120/240	(3000 min ⁻¹)	44.4	20	1.3	67.5		100/026/521	120/240/24E		
	29.6	21	1.2	101.3					29.6	25	1.0	101.3					
	22.2	25	1.0	135.0													
	14.8	25	1.0	202.5													
	11.1	25	1.0	270.0													
	8.9	25	1.0	337.5													
	7.4	25	1.0	405													
	12.0	25.0	1.0	250.1					070/026/522	120/240		44.4	25.0	1.0	67.5		180/026/521
	8.0	25.0	1.0	375.15		44.4	37				1.1	67.5		180/026/621	120/240		
	6.0	25.0	1.0	500.2													
	4.0	25.0	1.0	750.3													
	3.0	25.0	1.0	1000.4													
	2.4	25.0	1.0	1250.5													
	2.0	25.0	1.0	1500.6													
	1.1	25.0	1.0	2734													
	44.4	14.3	2.8	67.5		070/026/621	120/240		44.4	25.0	1.0	67.5		180/026/521	120/240		
	29.6	20.1	2.0	101.3					44.4	37	1.1	67.5					180/026/621
	22.2	25.4	1.6	135													
	14.8	34.0	1.2	202.5													
	11.1	40.0	1.0	270													
	8.9	40.0	1.0	337.5													
	7.4	40.0	1.0	405													
	12.0	50.0	1.0	250.1					070/026/622	120/240		29.6	40	1.0	101.3		
	8.0	50.0	1.0	375.15		22.2	40				1.0	135.0					
	6.0	50.0	1.0	500.2													
	4.0	50.0	1.0	750.3													
	3.0	50.0	1.0	1000.4													
	2.4	50.0	1.0	1250.5													
	2.0	50.0	1.0	1500.6													
	1.1	50.0	1.0	2734													

Nota: Verificare sempre che la coppia M2 utilizzata non ecceda il valore indicato nelle caselle in grigio

Note: Please check that the output torque M2 does not exceed the value into the grey areas

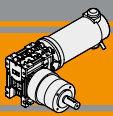

Dimensioni

Dimensions

NDWMP120/026/52...U

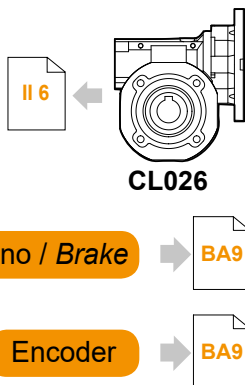
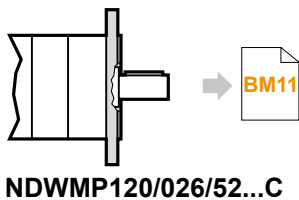
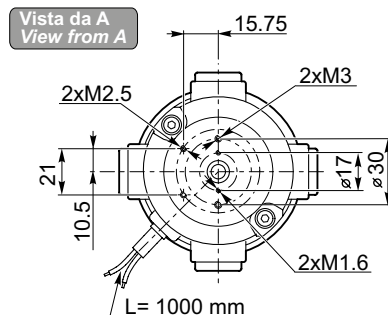
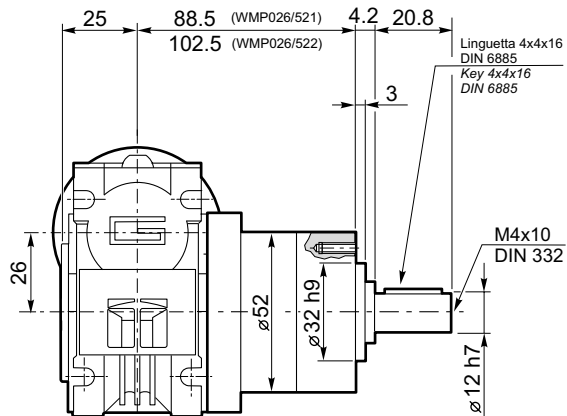
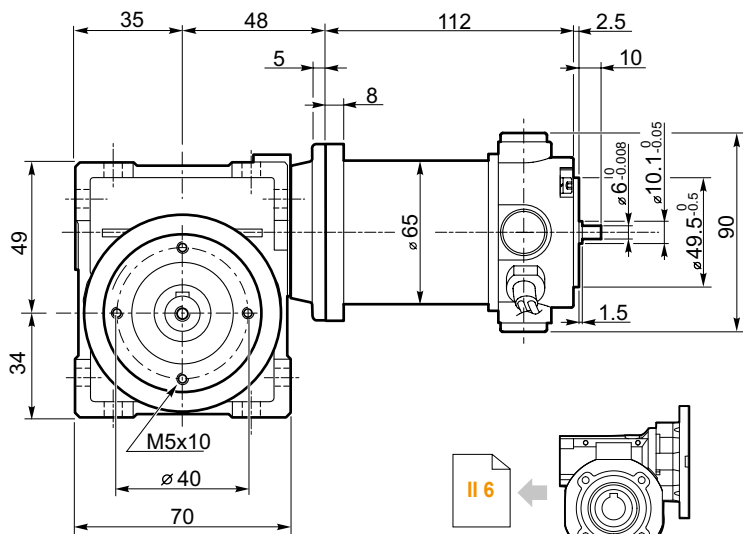

Freno / Brake → BA9

Encoder → BA9

NDWMP120/026/62...U

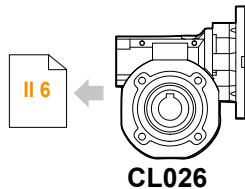
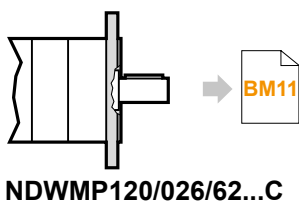
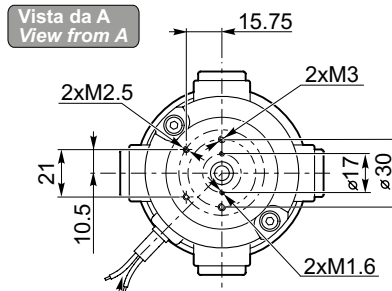
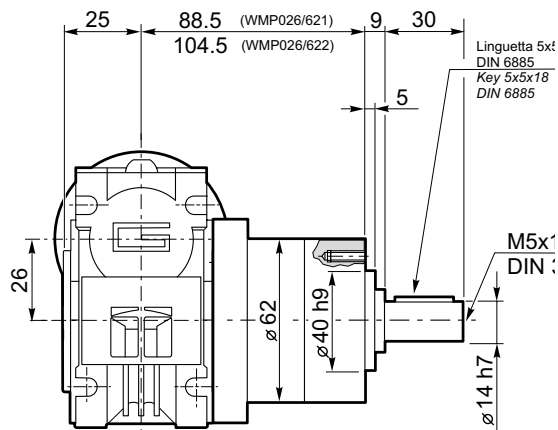
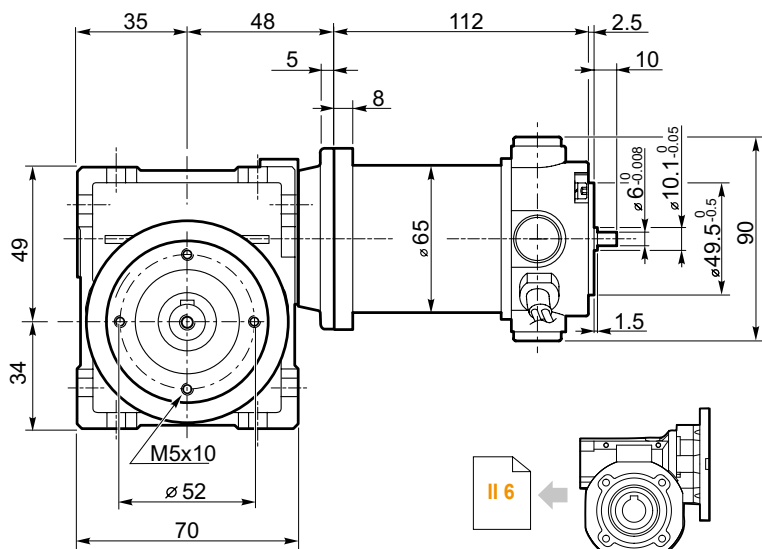

Freno / Brake → BA9

Encoder → BA9

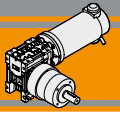

Dimensioni

Dimensions

NDWMP180/026/62...U

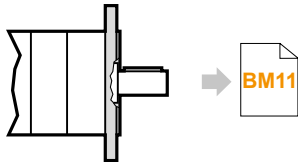
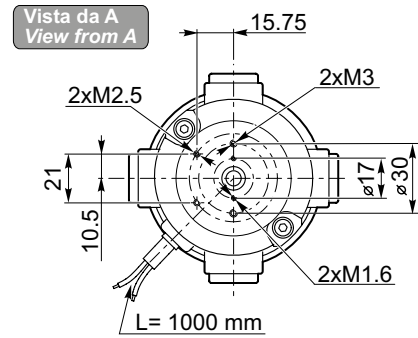
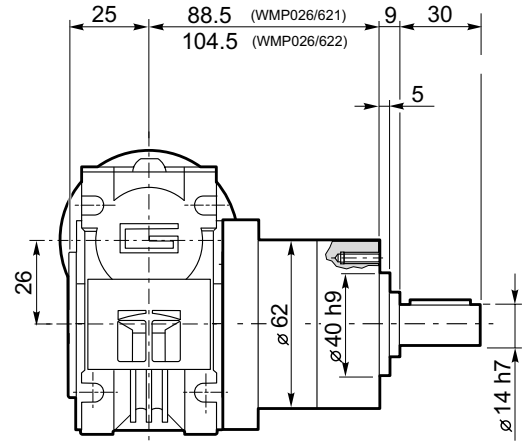
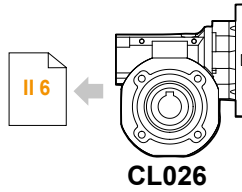
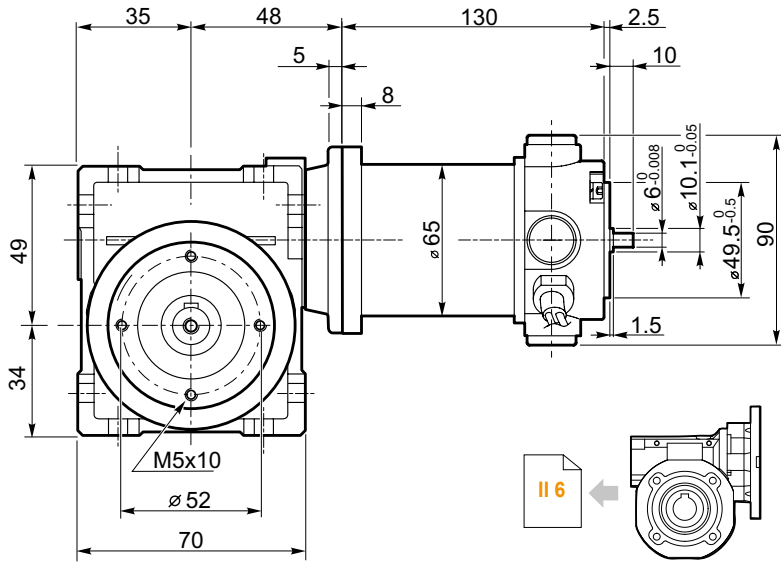

NDWMP180/026/62...C



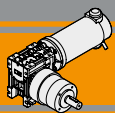

Dimensioni

Dimensions

ECWMP070/026/52...U

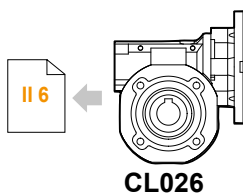
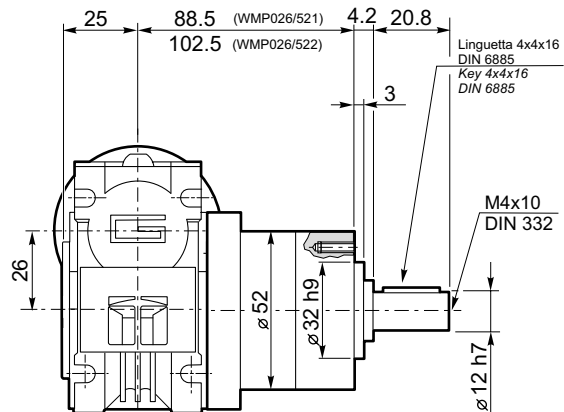
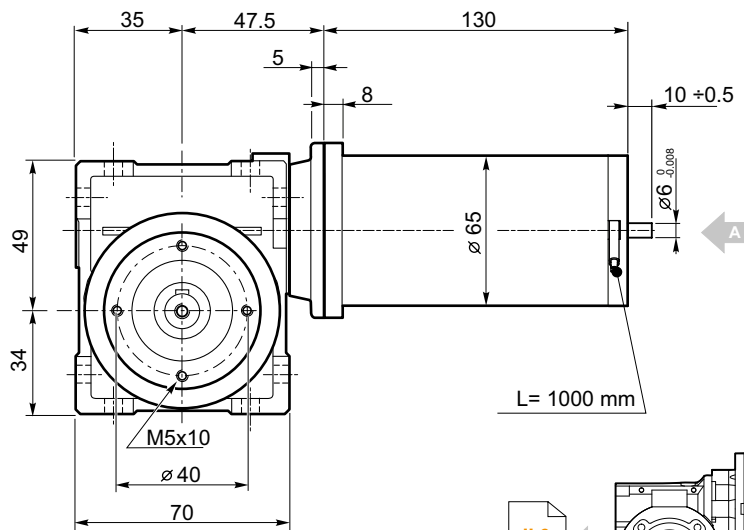

Vista / View
A

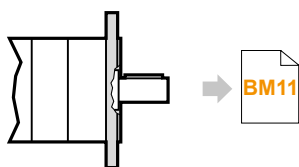
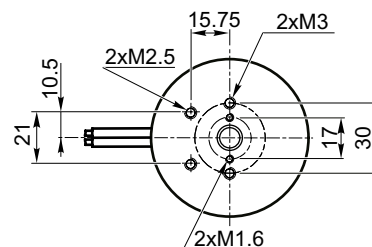

ECWMP070/026/52...C

Motors / Motors IP66



Brake / Freno



Encoder



ECWMP070/026/62...U

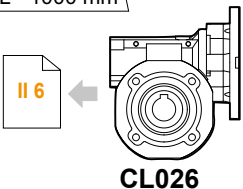
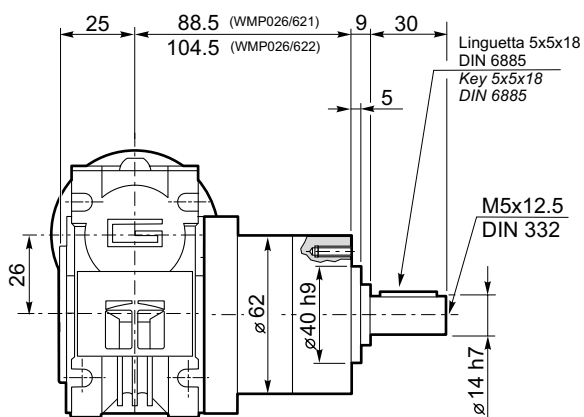
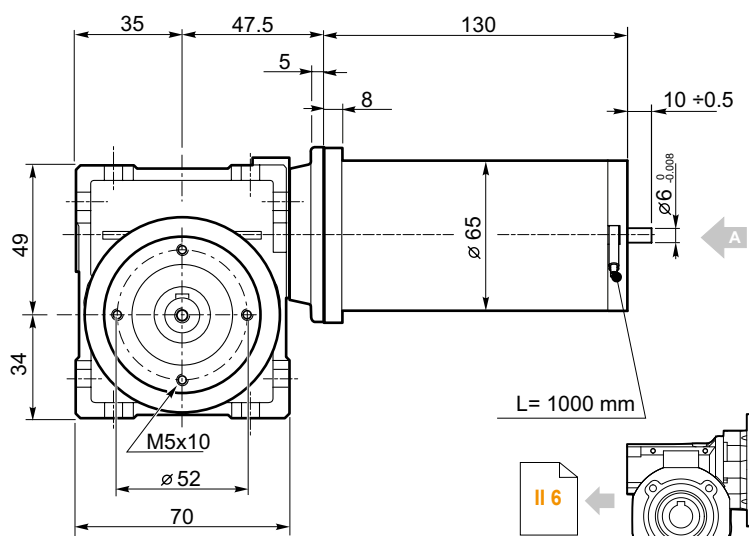

Vista / View
A

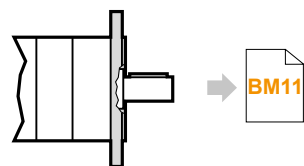
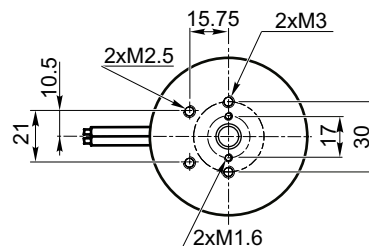

ECWMP070/026/62...C

Motors / Motors IP66



Brake / Freno



Encoder



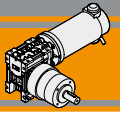

Dimensioni

Dimensions

ECWMP100/026/52...U

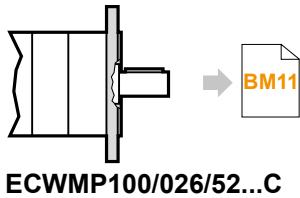
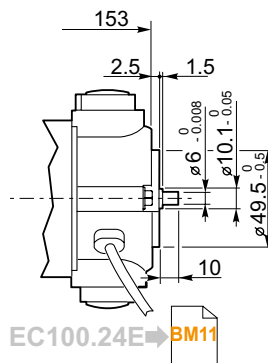
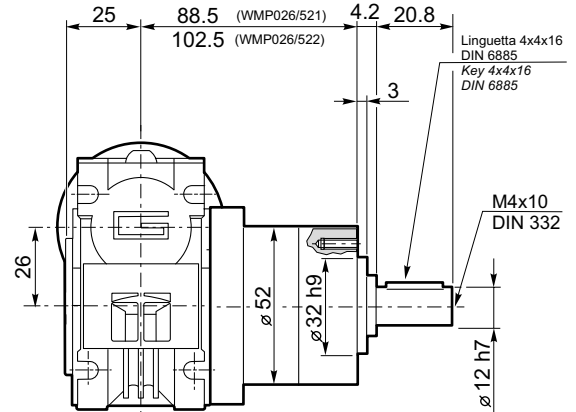
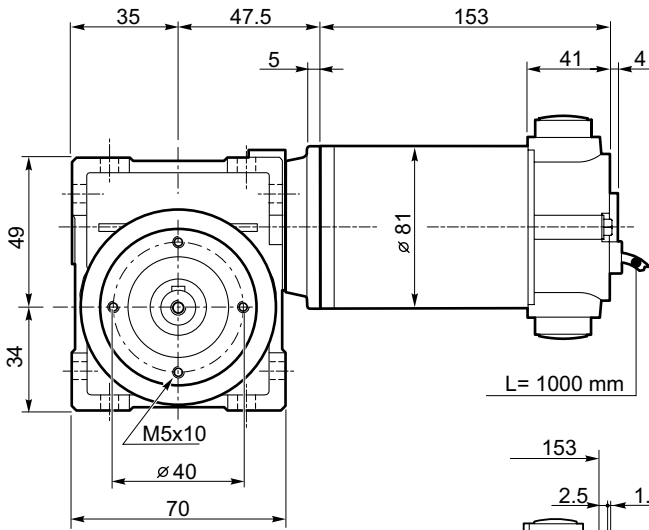

Motori / Motors IP66 →

BC4

Freno / Brake →

BB23

Encoder →

BB24

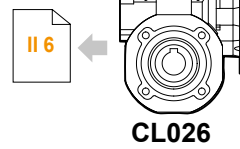

ECWMP100/026/62...U

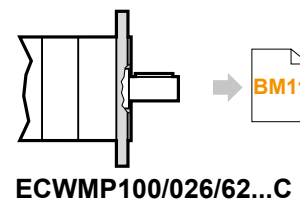
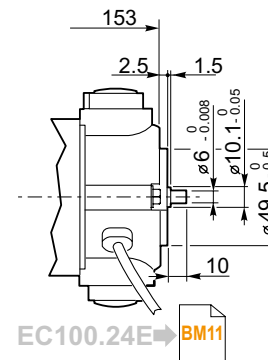
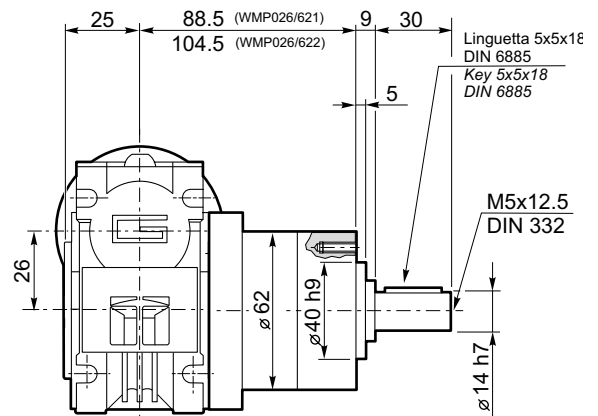
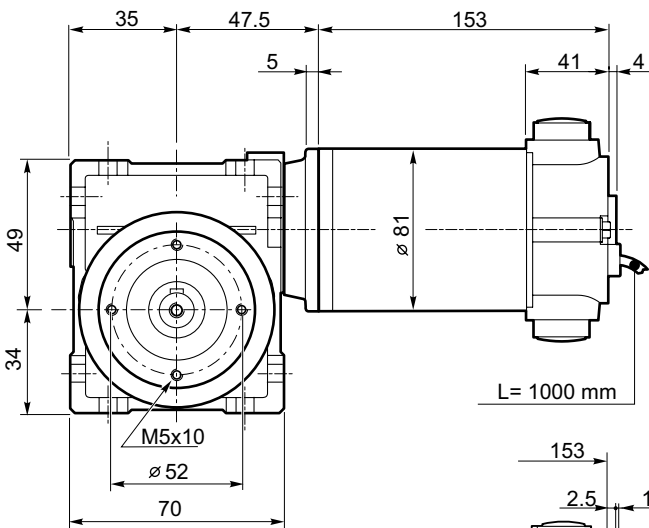

Motori / Motors IP66 →

BC4

Freno / Brake →

BB23

Encoder →

BB24

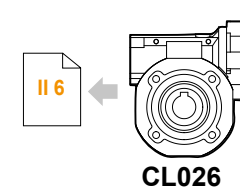

DC

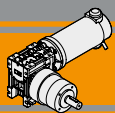

Dimensioni

Dimensions

ECWMP180/026/62...U

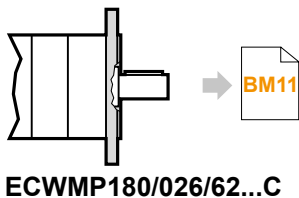
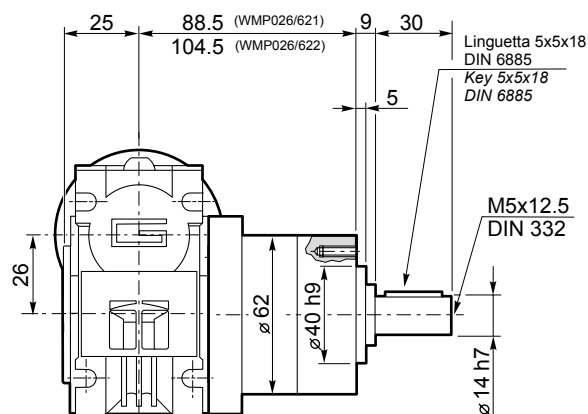
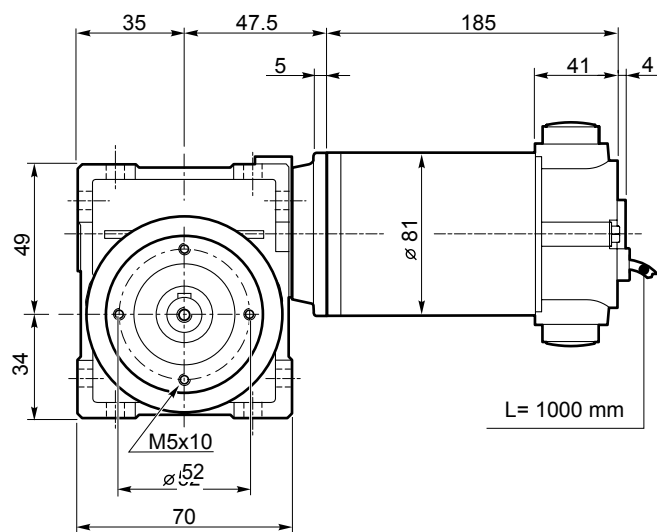

- Motori / Motors IP66 → **BC6**
- Freno / Brake → **BB23**
- Encoder → **BB24**

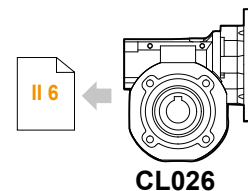

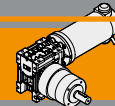

Dimensioni

Dimensions

ECWMP100.24E
ECWMP180.24E

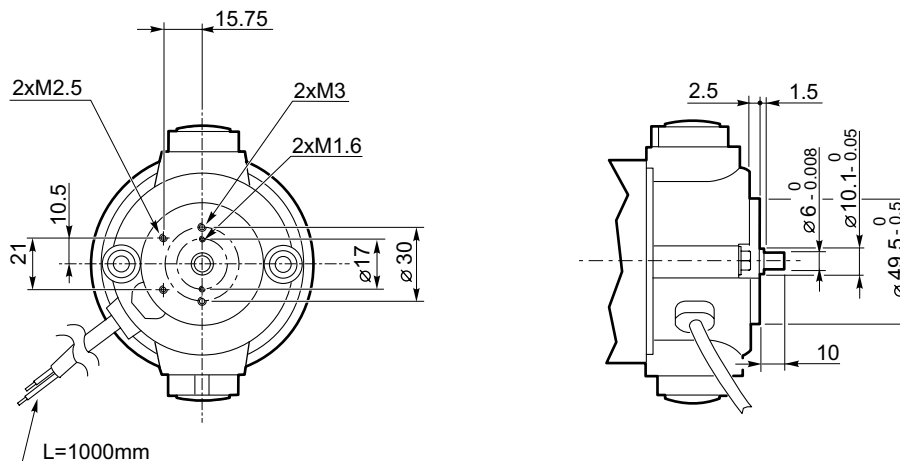

NDWMP.../.../... C... - ECWMP.../.../... C... Flange uscita / Output flanges

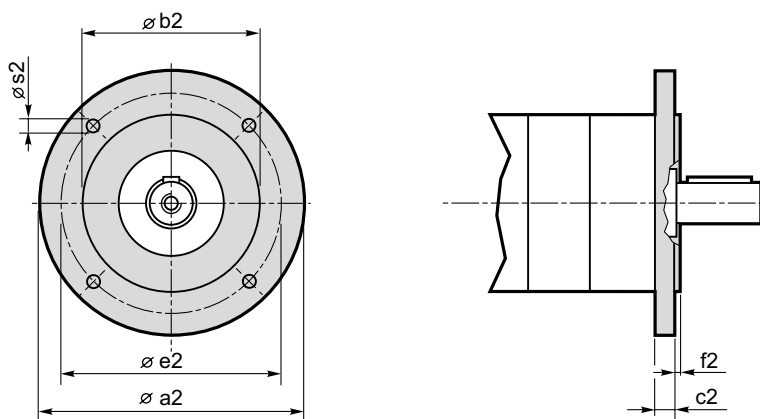

Dimensioni / Dimensions							
P	a2	b2	c2	e2	f2	s2	Flangia uscita Output flange
52	80	50 j7	9	65	2.5	M5	C80
	90	60 j7	9	75	2.5	5.5	C90
	105	70 j7	9	85	2.5	6.5	C105
	120	80 j7	9	100	3.0	6.5	C120
62	80	50 j7	9	65	2.5	M5	C80
	90	60 j7	9	75	2.5	5.5	C90
	105	70 j7	9	85	2.5	6.5	C105
	120	80 j7	9	100	3.0	6.5	C120

Azionamenti per motori CC
DC motor controls



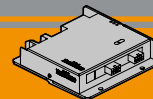

	Indice	Index	Pag. Page
PLN19-8	Schema dei collegamenti	<i>Main connection diagram</i>	BN2
	Caratteristiche tecniche	<i>Technical features</i>	BN2
	Dimensioni	<i>Dimensions</i>	BN3
	Opzioni	<i>Options</i>	BN3
PLN20 PLN40	Schema dei collegamenti	<i>Main connection diagram</i>	BN4
	Caratteristiche tecniche	<i>Technical features</i>	BN5
	Dotazioni	<i>Equipment</i>	BN5
	Manuale	<i>User manual</i>	BN5
	Dimensioni	<i>Dimensions</i>	BN6
	GUIDA alla selezione dell'azionamento	<i>Drive selection GUIDE</i>	BN7
	Note	<i>Note</i>	BN8

Questa sezione annulla e sostituisce ogni precedente edizione o revisione. Qualora questa sezione non Vi sia giunta in distribuzione controllata, l'aggiornamento dei dati ivi contenuto non è assicurato. **In tal caso la versione più aggiornata è disponibile sul nostro sito internet www.transtecno.com**

This section replaces any previous edition and revision. If you obtained this catalogue other than through controlled distribution channels, the most up to date content is not guaranteed. In this case the latest version is available on our web site www.transtecno.com

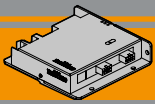

AZIONAMENTO UNIDIREZIONALE PWM PER LA REGOLAZIONE DI VELOCITA' DEI MOTORI A CORRENTE CONTINUA A BASSA TENSIONE

LOW VOLTAGE SINGLE DIRECTION PWM DC MOTORS CONTROL

SCHEMA DEI COLLEGAMENTI - MAIN CONNECTION DIAGRAM

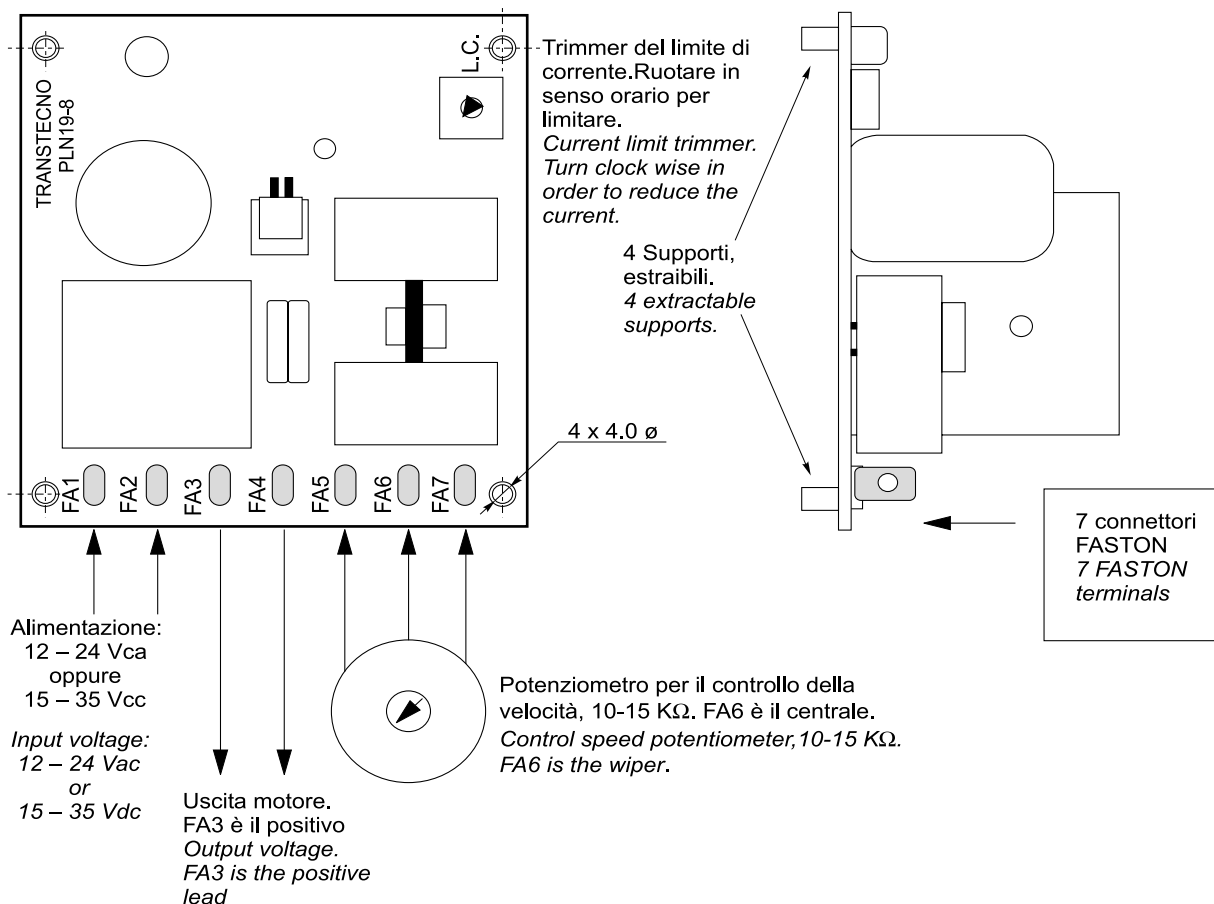

Attenzione: se si scollega il potenziometro con la scheda alimentata, il motore ruota alla velocità nominale.

Warning: if speed pot is disconnected when the board is powered, the motor runs at its maximum speed.

Caratteristiche tecniche

Technical features

- Alimentazione ai terminali FA1 e FA2:
12 - 24 Vca oppure 15 - 35 Vcc.
- Regolazione della velocità mediante potenziometro 10-15 KΩ.
- Trimmer di Limitazione della corrente, per adattare la scheda anche a motori di piccole potenze. Per limitare l'erogazione di corrente, ruotare in senso orario il trimmer.
- Uscita motore ai terminali FA3 e FA4, regolabile da 0 a Vcc MAX che è proporzionale alla tensione di ingresso. Con 35 Vcc di alimentazione, l'uscita MAX è circa 30 Vcc.
- Corrente di uscita (*): Massima corrente ammessa: 8 A in ambiente ventilato, servizio continuo.
- Peso: 0.120 Kg.
- Line voltage at terminals FA1 and FA2:
12 - 24 Vac or 15 - 35 Vdc.
- The speed of the drive is to be controlled by potentiometer, 10-15 KΩ.
- Current Limit trimmer, in order to suit the board for small motors. In order to limit the current, turn clock wise the trimmer.
- Output voltage from terminals FA3 and FA4, from 0 up to Vdc MAX which is proportional to the input voltage. With 35 Vdc input voltage, the max output voltage is about 30 Vdc.
- Output current (*): Maximum output current allowed: 8 A in a ventilated environment, continuous duty.
- Weight: 0.120 Kg.

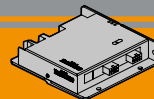

Dimensioni

Dimensions

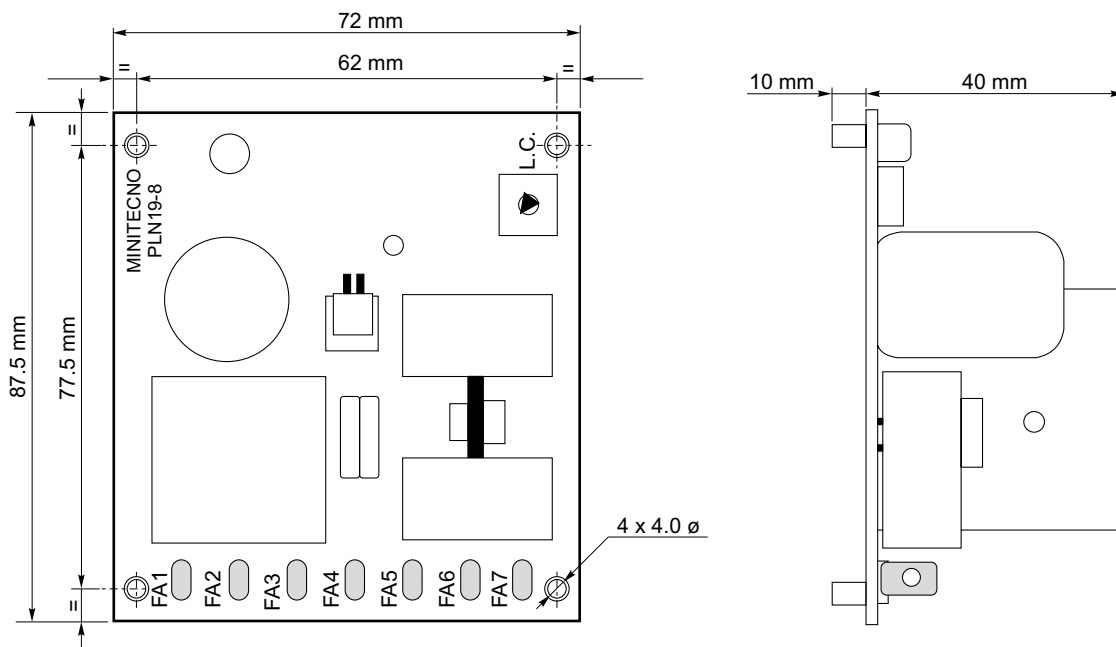

Opzioni

Options

1. Potenzimetro 10 kΩ
2. Supporto per montaggio su guida DIN

1. Speed potentiometer 10 kΩ
2. DIN mounting support

(*) il valore massimo di corrente motore deve essere utilizzato in **ambiente ventilato**. In ambienti non ventilati e per temperatura ambiente di 45 °C, ridurre la corrente motore massima a 4 A; servizio continuo.

(*) *the maximum output current value must be used in a ventilated environment. Derate the maximum output current down to 4 A if the environment is not ventilated and the temperature is about 45 °C; continuous duty.*

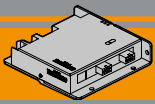

AZIONAMENTO BIDIREZIONALE PWM PER LA REGOLAZIONE DI VELOCITA' DEI MOTORI A CORRENTE CONTINUA A BASSA TENSIONE

LOW VOLTAGE BIDIRECTIONAL PWM DC MOTORS CONTROL

SCHEMA DEI COLLEGAMENTI - MAIN CONNECTION DIAGRAM

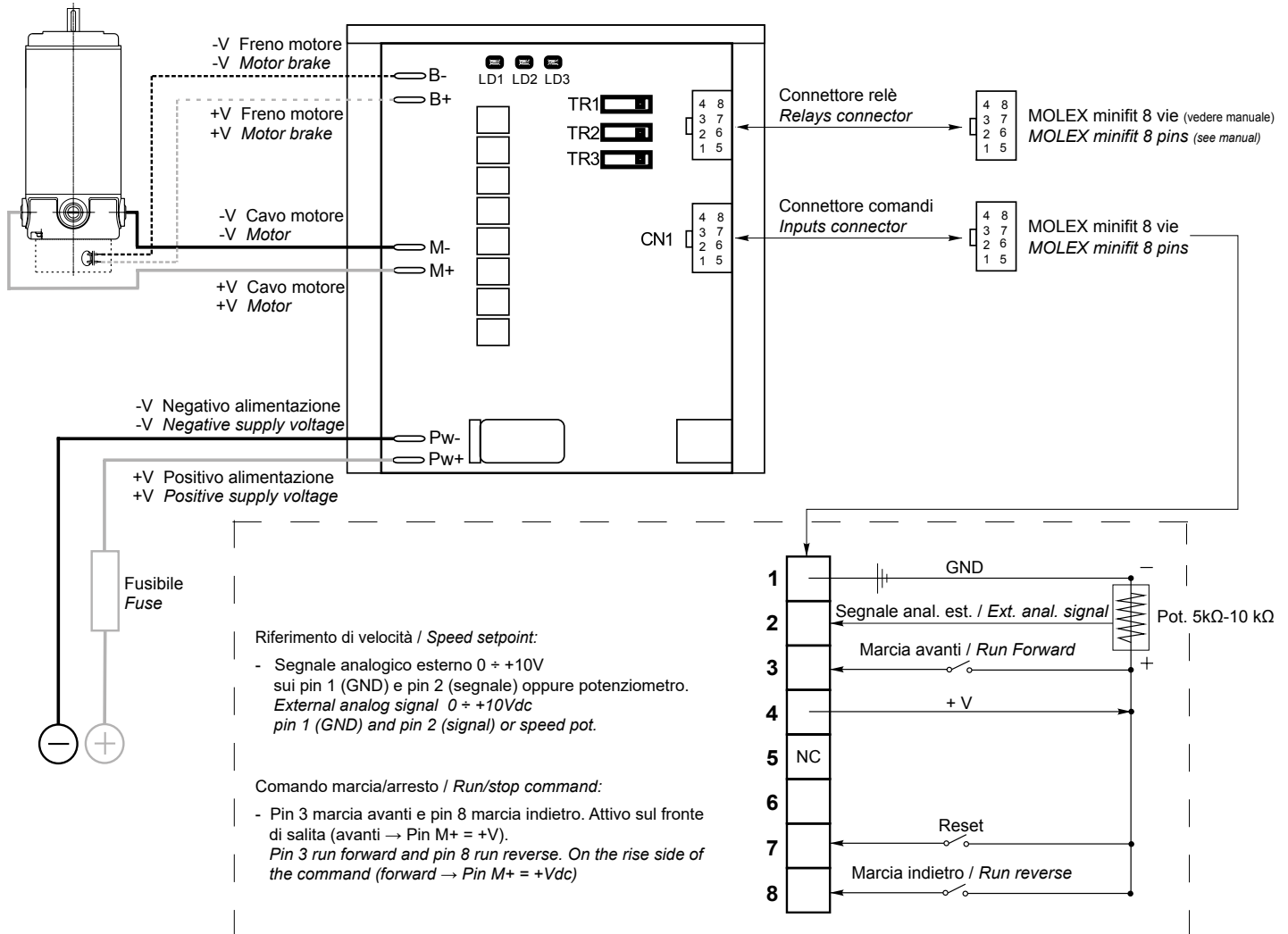

Fusibile:

150-200% della corrente motore. Max 3 volte la corrente nominale della scheda, con intervento entro pochi secondi.

Fuse:

150-200 % rated motor current. Max 3 times rated current of the drive (trip time in few seconds).

Trimmer multigiro:

TR1: Accelerazione: selezione da 0.5 a 10 sec.

TR2: Limite di corrente: riduce il limite di corrente nominale da 100% a circa 30% (corrente di picco 3 volte la corrente selezionata).

TR3: Decelerazione: selezione da 0.5 a 10 sec.

Multiturn trimmers:

TR1: Acceleration time: from 0.5 to 10 sec.

TR2: Current limitation: rated current limited from 100% to about 30% (peak current 3 times the selected limited current).

TR3: Deceleration time: from 0.5 to 10 sec.

LED:

LD1: Visualizza lo stato di funzionamento con limite di corrente attivo (il motore assorbe più della corrente selezionata e l'azionamento opera in limitazione).

LD2: Stato dell'azionamento: lampeggio veloce e continuo = funzionamento normale, lampeggio lento e codificato = presenza di un allarme

LD3: Segnalazione presenza alimentazione.

LED:

LD1: ON when the drive runs under current limitation (motor requires more than the rated current and drive supplies only limited current).

LD2: Status: quick continuous flash = drive ok, slow coded flash = fault).

LD3: Power ON

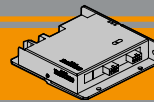

Caratteristiche tecniche

Technical features

- Scheda bidirezionale a transistor a ricircolo di corrente.
 - Selezionabili i seguenti parametri (mediante trimmer):
 - rampa di accelerazione: 0.5 - 10 sec
 - rampa di decelerazione: 0.5 - 10 sec
 - limite corrente 100%-30% circa
 - Temperatura di lavoro: 0°C / +40°C (allarme sotto zero)
 - Diagnostica tramite LED
 - Frequenza di commutazione: 16kHz
 - Dotata di coperchio
 - Velocità regolabile con potenziometro 5-10 kΩ o con segnale 0-10 Vcc
 - Limitazione della corrente regolabile
 - Sensore termico di protezione
- *Transistor bidirectional drive with regenerative current system.*
 - *Following settings can be adjusted (by built in trimmers):*
 - *acceleration ramp: 0.5 - 10 sec*
 - *deceleration ramp: 0.5 - 10 sec*
 - *current limit 100% - about 30%*
 - *Room temperature: 0°C / +40°C (alarm below zero)*
 - *LED for system diagnosis*
 - *Switching frequency: 16kHz*
 - *Covered*
 - *5-10 kΩ Speed pot. or 0-10 Vdc external signal for speed regulation*
 - *Variable current limit*
 - *Thermal sensor for protection*

Modello Model number	Tensione di alimentazione DC input voltage [Vdc]	Tensione di uscita Motor voltage [Vdc]*	Corrente di uscita nominale DC load current [A]	Corrente di picco motore Maximum load current [A]**	Campo di alimentazione Power supply range [Vdc]
PLN20	12 ÷ 24	0 ÷ Vin	20	60 (4 sec)	10 ÷ 30
PLN40	12 ÷ 24	0 ÷ Vin	40	120 (1 sec)	10 ÷ 30

* L'azionamento riduce la tensione nominale di 1-2 Vcc. Il fenomeno è normale e fisiologico. Se serve ottenere 24 ÷ 12 Vcc in uscita sotto ogni condizione di carico, si suggerisce di sovralimentare di un paio di volt.

** Un timer impone il limite con un andamento temporale iperbolico, cioè quanta più corrente eroga e tanto meno è il tempo per il quale ciò è ammesso, prima che appunto la scheda vada in limitazione. Alla corrente di picco (x 3 volte quella nominale) la scheda funziona per pochi secondi.

* *The drive reduces the rated voltage of 1-2 Vdc. This is normal and physiological. If 24 ÷ 12 VDC output is required under all load conditions, it is advisable to supercharge a couple of volts.*

** *A timer imposes a limit with a temporary hyperbolic performance, which means the more current is requested, the less time is permitted with this current before the drive is limited. When the current reaches its peak (3 times the rated value) the drive will work for a few seconds.*

Dotazioni

Equipment

	PLN20 PLN40
Trimmer di selezione ACCEL, DECEL e LIMITE di CORRENTE / <i>Selection Trimmer ACCEL, DECEL, CURRENT LIMIT</i>	■
2 contatti: marcia avanti e marcia indietro / <i>2 contacts : forward and reverse</i>	■
Riferimento di velocità / <i>Speed setpoint reference</i>	■
3 LEDs di segnalazione / <i>3 LEDs signals</i>	■
Segnale di comando di eventuale freno negativo di stazionamento / <i>Command signal for possible negative electromagnetic brake</i>	■
Predisposizione per montaggio a libro e a zoccolo / <i>Arranged for 2 different ways of mounting</i>	■
Memorizzazione e segnalazione degli allarmi / <i>Memory storage and report of alarm</i>	■
2 ingressi digitali ausiliari / <i>2 auxiliary digital inputs</i>	■#
1 relè segnalazione allarmi / <i>Alarm output relays</i>	■

uno impegnato dal reset / *one comitted by reset*



Manuale



User manual

Per approfondimenti si raccomanda di scaricare il manuale d'uso dal nostro sito www.transtecno.com alla pagina dei prodotti.

Please, download the user manual for more information from our web site www.transtecno.com from the product page.

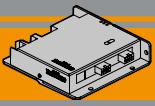

**AZIONAMENTO BIDIREZIONALE PWM PER LA
REGOLAZIONE DI VELOCITA' DEI MOTORI A
CORRENTE CONTINUA A BASSA TENSIONE**

**LOW VOLTAGE BIDIRECTIONAL
PWM DC MOTORS CONTROL**

Dimensioni

Dimensions

PLN20

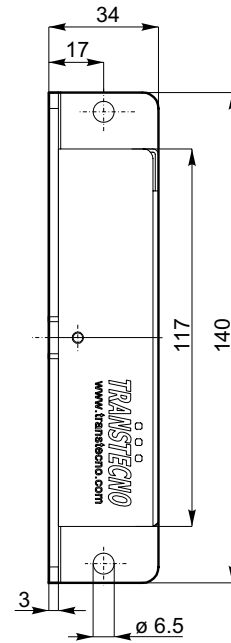
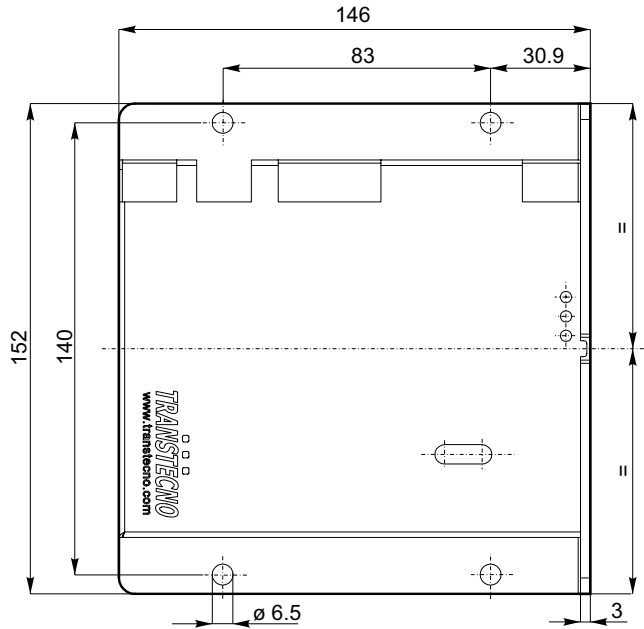

PLN40

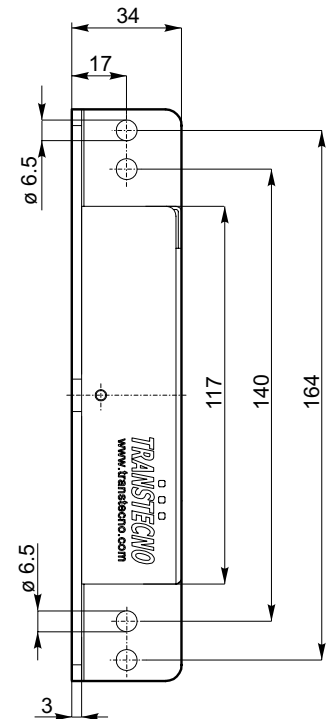
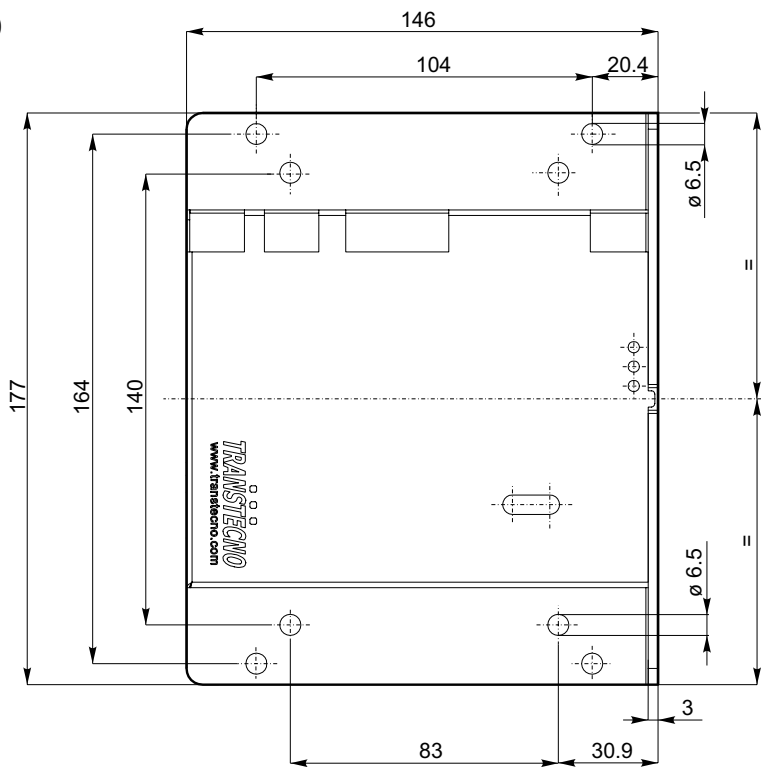

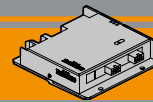

GUIDA alla selezione dell'azionamento

Drive selection GUIDE

Corrente di uso del motore ≤ Corrente nominale dell'azionamento

Real motor current ≤ Rated current of the drive

Attenzione: la reale corrente assorbita dal motore può essere diversa da quella indicata in targhetta.

Warning: the real absorbed current by the motor can be different from the one written on the nameplate.

PLN19-8 = max 6 A

PLN19-8 = max 6 A

PLN20 = max 22 A

PLN20 = max 22 A

PLN40 = max 44 A

PLN40 = max 44 A

Vedere sotto la tabella per esemplificazioni

See the table below for quick reference

Codice motore Motor code	Corrente motore Motor current S1	Scheda-Drive (servizio motore-motor duty) S1	Corrente motore Motor current S2	Scheda-Drive (servizio motore-motor duty) S2
EC020.120	3.2	PLN19-8 – PLN20	4	PLN19-8 – PLN20
EC020.240	1.5	PLN19-8 – PLN20	2	PLN19-8 - PLN20
EC035.120	5.2	PLN19-8 – PLN20	8	PLN20
EC035.240	2.6	PLN19-8 - PLN20	4	PLN19-8 - PLN20
EC050.120	6.8	PLN20	9.4	PLN20
EC050.240	3.4	PLN19-8 - PLN20	4.7	PLN19-8 - PLN20
EC070.120	8.4	PLN20	11.8	PLN20
EC070.240	4.2	PLN19-8 - PLN20	5.9	PLN19-8 - PLN20
EC100.120	12	PLN20	16.8	PLN20
EC100.240	6	PLN19-8 - PLN20	8.4	PLN20
EC100.24E	6	PLN19-8 - PLN20	8.4	PLN20
ND100.120	13.9	PLN20	19	PLN20
ND100.240	6.9	PLN20	9.0	PLN20
EC180.120	21.5	PLN20	30	PLN40
EC180.240	10.8	PLN20	15	PLN20
EC180.24E	10.8	PLN20	15	PLN20
ND180.120	20	PLN20	30	PLN40
ND180.240	10	PLN20	14	PLN20
EC250.120	30	PLN40	39	PLN40
EC250.240	15	PLN20	19.5	PLN20
EC350.240	21	PLN20	29.4	PLN40
EC350.240BR				
EC600.240	35.5	PLN40	47	PLN40
EC600.240BR				

MINI  **TECNO**
small but strong



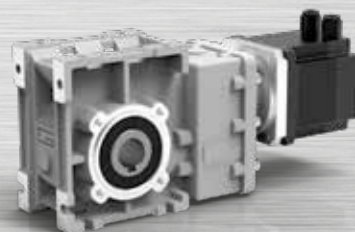
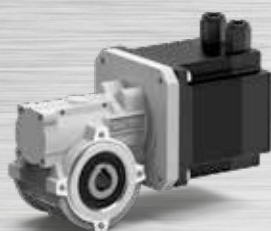
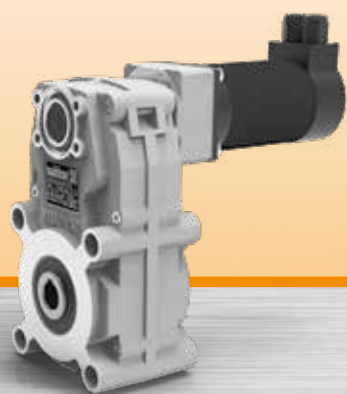







Motoriduttori BLDC
BLDC gearmotors



MINI  **TECNO** brand of
TRANSTECNO

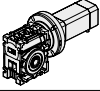

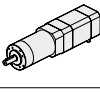
BLDC

	Indice	Index	Pag. Page
 	C-A Motori brushless CC BL	Brushless DC motors BL	C-A1
 	C-B Motoriduttori brushless CC ad assi ortogonali BLCMB	Brushless DC helical bevel gearmotors BLCMB	C-B1
 	C-C Motoriduttori brushless CC pendolari BLFT	Brushless DC helical parallel gearmotors BLFT	C-C1
 	C-D Motoriduttori brushless CC a vite senza fine BLCM	Brushless DC wormgearmotors BLCM	C-D1
 	C-E Motoriduttori brushless CC epicicloidali BLP	Brushless DC planetary gearmotors BLP	C-E1
 	C-F Azionamenti per motori brushless CC BLD	Brushless DC motor controls BLD	C-F1

Questo catalogo annulla e sostituisce ogni precedente edizione o revisione.
Ci riserviamo inoltre il diritto di apportare modifiche senza preavviso.
La versione più aggiornata è disponibile sul sito
www.transtecno.com

*This catalogue supersedes any previous edition and revision.
We reserve the right to implement modifications without notice.
The most updated version is available on our website
www.transtecno.com*

MINI  **TECNO**
small but strong

BL



Motori brushless CC
Brushless DC motors

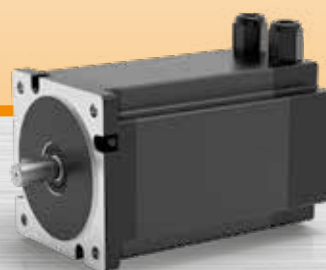
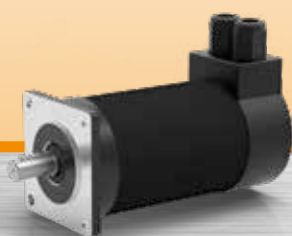

MINI  **TECNO** brand of
TRANSTECNO



BLDC

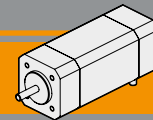

	Indice	Index	Pag. Page
	Caratteristiche tecniche	<i>Technical features</i>	CA2
	Grado di protezione IP	<i>IP enclosures protection indexes</i>	CA2
	Classe di isolamento termico	<i>Insulation class</i>	CA2
	Tipi di servizio IEC	<i>IEC duty cycle ratings</i>	CA2
	Legenda / Glossario dei grafici	<i>Key / Diagram Glossary</i>	CA3
	Formule utili	<i>Useful formulas</i>	CA3
BLS022.240	Specifiche costruttive	<i>General features</i>	CA4
	Prestazioni	<i>Performances</i>	CA4
	Dimensioni	<i>Dimensions</i>	CA5
	Diagramma dei collegamenti	<i>Connection diagram</i>	CA5
BLS043.240	Specifiche costruttive	<i>General features</i>	CA6
	Prestazioni	<i>Performances</i>	CA6
	Dimensioni	<i>Dimensions</i>	CA7
	Diagramma dei collegamenti	<i>Connection diagram</i>	CA7
BL070.480	Specifiche costruttive	<i>General features</i>	CA8
	Prestazioni	<i>Performances</i>	CA8
	Dimensioni	<i>Dimensions</i>	CA9
	Diagramma dei collegamenti	<i>Connection diagram</i>	CA9
BL140.480	Specifiche costruttive	<i>General features</i>	CA10
	Prestazioni	<i>Performances</i>	CA10
	Dimensioni	<i>Dimensions</i>	CA11
	Diagramma dei collegamenti	<i>Connection diagram</i>	CA11
BL210.480	Specifiche costruttive	<i>General features</i>	CA12
	Prestazioni	<i>Performances</i>	CA12
	Dimensioni	<i>Dimensions</i>	CA13
	Diagramma dei collegamenti	<i>Connection diagram</i>	CA13

Questa sezione annulla e sostituisce ogni precedente edizione o revisione. Qualora questa sezione non Vi sia giunta in distribuzione controllata, l'aggiornamento dei dati ivi contenuto non è assicurato. **In tal caso la versione più aggiornata è disponibile sul nostro sito internet www.transtecno.com**

This section replaces any previous edition and revision. If you obtained this catalogue other than through controlled distribution channels, the most up to date content is not guaranteed. In this case the latest version is available on our web site www.transtecno.com

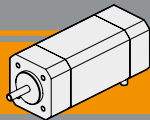

Caratteristiche tecniche

Technical features

I motori brushless CC della serie BL vengono realizzati in 5 taglie con coppie da 0.22 Nm a 2.1 Nm, e sono forniti con driver esterno.

I vantaggi di utilizzare i motori brushless anziché i tradizionali motori cc a spazzole, sono i seguenti:

- Lunga durata nel tempo
- Elevata efficienza
- Commutazione elettronica e controllo del motore tramite sensori digitali (encoder, resolver ecc..)
- Ampio campo di regolazione della velocità
- Mancanza di manutenzione

I motori della serie BL sono estremamente compatti e grazie al basso momento di inerzia offrono una elevata prestazione dinamica, ed inoltre sono economici in quanto dotati di sensori di Hall (anziché encoder o resolver).

Le 3 fasi dell'avvolgimento del motore sono a bassa tensione 24V / 36V / 48V e quindi offrono maggiori garanzie in termini di sicurezza dell'impianto, soprattutto nelle applicazioni dove l'operatore può essere a contatto con il motore stesso.

Tutti i motori sono realizzati con grado di protezione IP55.

Brushless DC motors from the BL range are available in 5 sizes with torque from 0.22 Nm to 2.1 Nm and they are supplied with external driver.

The advantages of using brushless motors instead of traditional DC brushed motors are the following:

- Longer life time
- Higher efficiency
- Electronic commutation and control of the motor via digital sensors (encoder, resolver etc.)
- Wide speed range
- Maintenance free

BL motors have a compact design and thanks to low inertia they have high performances and are a low cost solution already including Hall sensors, as opposed to an encoder or resolver.

The 3 phase windings of the motor have a low voltage of 24/36/48 V and so these motors are safer to use when a machine operator has direct contact with them.

IP55 protection index for all the motors.

Grado di protezione IP

IP enclosures protection indexes

Indica il grado di isolamento meccanico del corpo motore.

1^a cifra protezione alla penetrazione di corpi solidi.

2^a cifra protezione contro la penetrazione d'acqua.

Indicates the degree of mechanical insulation of the motor body. 1st figure indicating level of protection against the penetration of solid bodies.

2nd figure: indicating degree to which the motor is waterproof.

5	Protetto contro la polvere <i>Dust proof</i>	5	Protetto contro i getti d'acqua <i>Water jet proof</i>
----------	---	----------	---

Classe di isolamento termico

Insulation class

Classe / Class	Δt °C Temp. ambiente: 40°C Ambient temperature: 40°C
B	90°C
F	115°C
H	140°C

Tipi di servizio IEC

IEC duty cycle ratings

S1	Servizio continuo. Funzionamento a carico costante per una durata sufficiente al raggiungimento dell'equilibrio termico.	Continuous duty. The motor works at a constant load for enough time to reach temperature equilibrium
S2	Servizio di durata limitata. Funzionamento a carico costante per una durata inferiore a quella necessaria al raggiungimento dell'equilibrio termico, seguito da un periodo di riposo tale da riportare il motore alla temperatura ambiente.	Short time duty. The motor works at a constant load, but not long enough to reach temperature equilibrium, and the rest periods are long enough for the motor to reach ambient temperature.
S3	Servizio periodico intermittente. Sequenze di cicli identici di marcia e di riposo a carico costante, senza raggiungimento dell'equilibrio termico. La corrente di spunto ha effetti trascurabili sul surriscaldamento del motore.	Intermittent periodic duty. Sequential, identical run and rest cycles with constant load. Temperature equilibrium is never reached. Starting current has little effect on temperature rise.

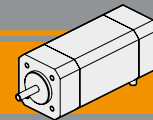

Legenda / Glossario dei grafici

Key / Diagram Glossary

Dato un motore brushless CC, la velocità di rotazione è funzione lineare della coppia; così pure la corrente assorbita è una funzione lineare della coppia. Velocità e corrente variano in maniera sensibile al variare del carico.

With a brushless DC motor, the rotational speed is a linear function of the torque. In the same way, the absorbed current is also a linear function of the torque. Speed and current change a lot against applied torque.

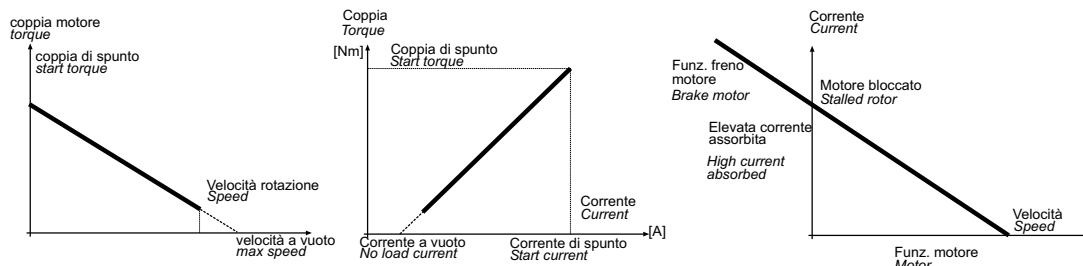

La potenza utile (potenza all' albero) si ricava dalla formula:

$$P_n [W] = M_n \cdot S = \frac{2\pi}{60} \cdot n_1 \cdot M_n$$

The output power is calculated using the formula:

$$P_n [W] = M_n \cdot S = \frac{2\pi}{60} \cdot n_1 \cdot M_n$$

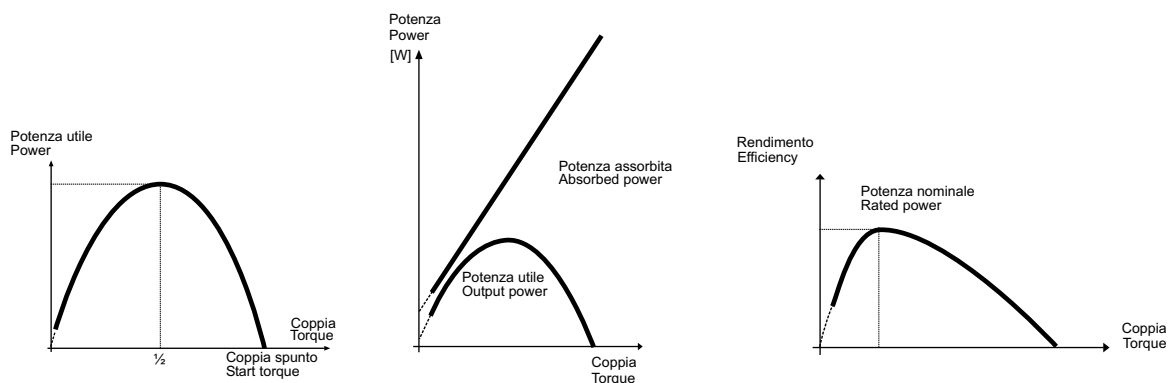

Poiché la tensione di alimentazione è costante mentre la corrente è linearmente crescente al crescere della coppia, l'andamento della potenza assorbita è una retta crescente. Dal rapporto tra la potenza meccanica e la potenza assorbita si ottiene il grafico dell'efficienza.

Since the supply voltage is constant, whereas the current increases in a linear manner as the torque increases, the absorbed power trend is a straight line going up. Efficiency is shown from the ratio between the output power and the absorbed power.

Formule utili

Useful formulas

$$\eta = \frac{P_n}{P_a}$$

$$P_a = V \cdot I$$

$$P_n = V \cdot I \cdot \eta$$

$$P_n = M_n \cdot S_v$$

$$S_v = \frac{n_1}{9.55}$$

$$\eta = \frac{P_n}{P_a}$$

$$P_a = V \cdot I$$

$$P_n = V \cdot I \cdot \eta$$

$$P_n = M_n \cdot S_v$$

$$S_v = \frac{n_1}{9.55}$$

[HP] · 746 = [W].
Esempio 2 HP = circa 1500 W.

[HP] · 746 = [W].
Example 2 HP = approx. 1500 W.

S	—	Servizio	<i>Duty</i>
P_n	[W]	Potenza in uscita	<i>Rated power</i>
P_a	[W]	Potenza assorbita	<i>Absorbed power</i>
M_n	[Nm]	Coppia nominale	<i>Rated torque</i>
V	[V]	Tensione	<i>Voltage</i>
I	[A]	Corrente assorbita	<i>Absorbed current</i>
n₁	[min ⁻¹]	Numero giri motore	<i>Motor speed</i>
S_v	[rad/s]	Velocità angolare	<i>Angular speed</i>
IC	—	Classe d'isolamento termico	<i>Thermal insulation class</i>
FF	—	Fattore di forma	<i>Form factor</i>
IP	—	Classe di protezione	<i>protection class</i>
η	—	Rendimento	<i>Efficiency</i>
Kg	—	Massa	<i>Mass</i>

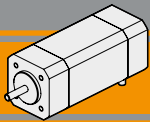

BLS022.240

Specifiche costruttive

General features

Tipologia di avvolgimento <i>Winding type</i>	delta	Max forza radiale <i>Max radial force</i>	75N @ 20 mm dalla flangia 75N @ 20 mm from flange
Angolo sensori Hall <i>HALL effect angle</i>	120 gradi elettrici 120 degree electrical angle	Max forza assiale <i>Max axial force</i>	15N
Gioco radiale <i>Radial play</i>	0.025 mm @ 460 g	Classe di isolamento termico <i>Insulation class</i>	Classe B Class B
Gioco assiale <i>End play</i>	0.025 mm @ 4000 g	Isolamento dielettrico <i>Dielectric strength</i>	500Vcc x 1 minuto 500 Vdc 1 minute
Scentratura albero <i>Shaft run out</i>	0.025 mm	Resistenza isolamento <i>Insulation resistance</i>	100MΩ minimo, 500Vcc 100MΩ min, 500 Vdc

Modello <i>Model</i>	Poli <i>Poles</i>	Fasi <i>Phases</i>	Tensione nominale	Velocità nominale	Coppia nominale	Potenza nominale	Coppia di picco	Corrente nominale	Corrente di picco	Resistenza fase-fase	Induttanza fase-fase	Costante di coppia	Costante FCEM	Inerzia rotore	Peso
			<i>Rated voltage</i>	<i>Rated speed</i>	<i>Rated torque</i>	<i>Rated power</i>	<i>Peak torque</i>	<i>Rated current</i>	<i>Peak current</i>	<i>Line to line resistance</i>	<i>Line to line inductance</i>	<i>Torque constant</i>	<i>Back EMF</i>	<i>Rotor inertia</i>	<i>Weight</i>
			[V]	[min ⁻¹]	[Nm]	[W]	[Nm]	[A]	[A]	[Ω]	[mH]	[Nm/A]	[V/kRPM]	[gcm ²]	[kg]
BLS022.240	4	3	36	4000	0.22	92	0.66	3.7	11.2	0.64	2.1	0.06	6.28	119	0.72
BLS022.240	4	3	24	3000	0.22	70	0.66	3.7	11.2	0.64	3.1	0.06	6.28	119	0.72



Prestazioni

Performances

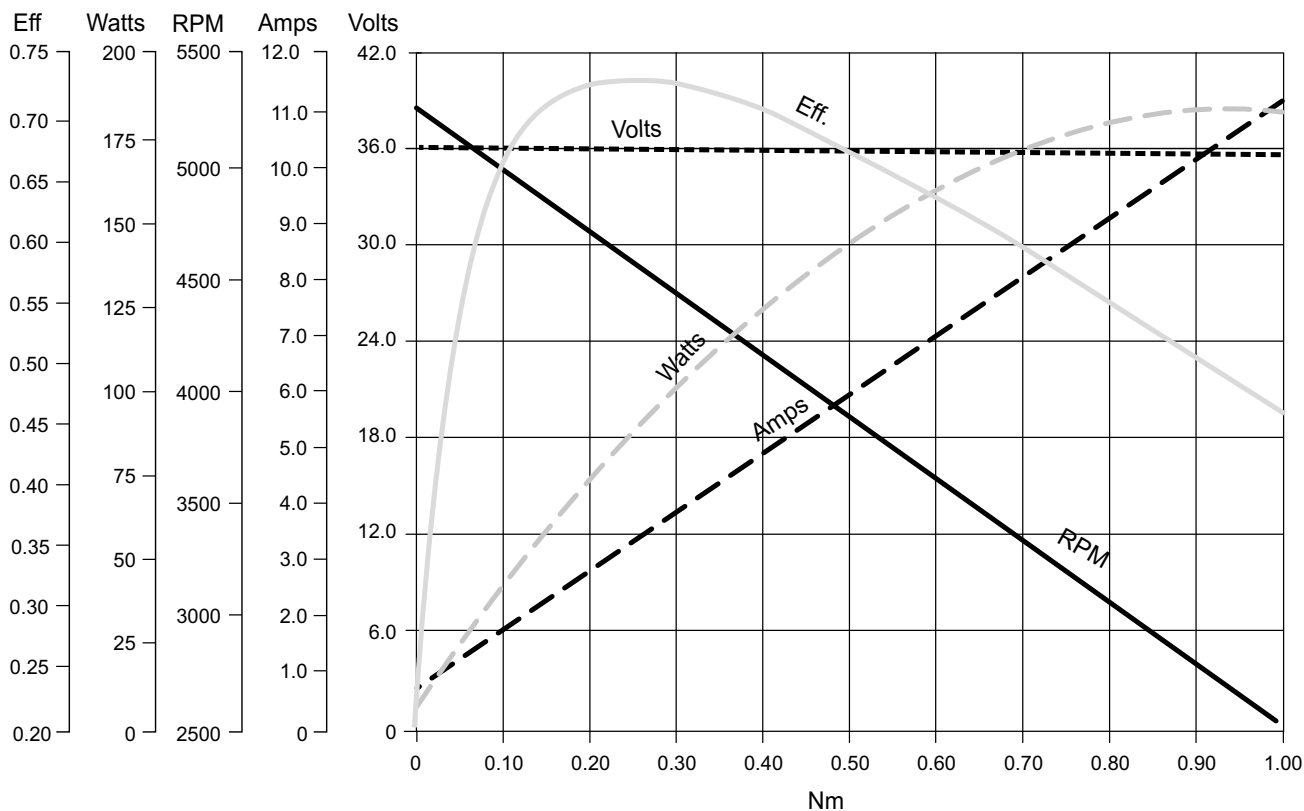

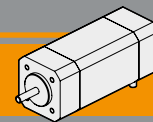
BLS022.240
Dimensioni
Dimensions
BLS022.240

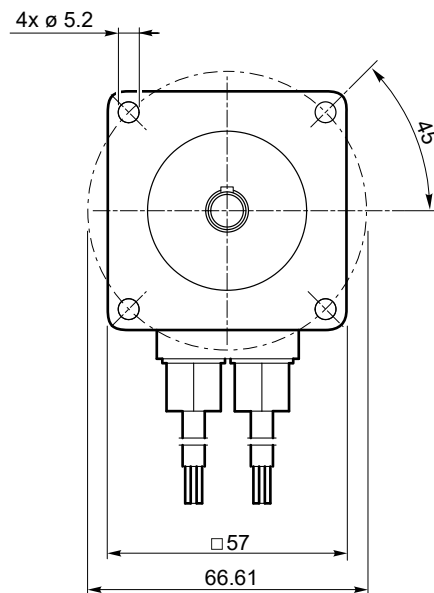
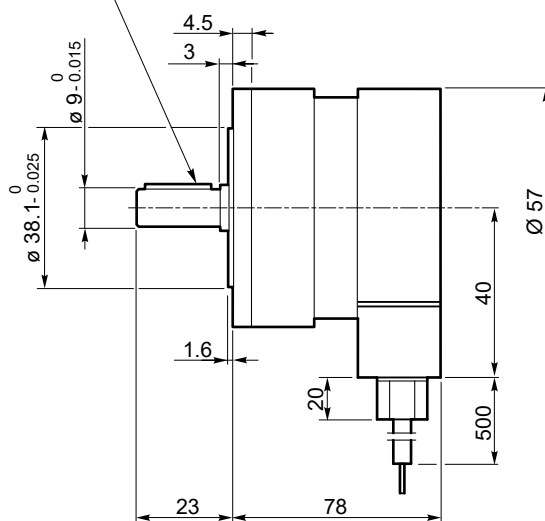
 Linguetta 3x3x16
 DIN 6885
 Key 3x3x16
 DIN 6885

Diagramma dei collegamenti
Connection diagram

Cavi di potenza Power leads	Descrizione Description
Giallo / Yellow	Fase U / U motor Phase
Rosso / Red	Fase V / V motor Phase
Nero / Black	Fase W / W motor Phase

Nota: Si raccomanda di seguire fedelmente gli schemi di collegamento qui riportati, pericolo di danneggiamento del motore o dell'elettronica.

Note: Pls, follow strictly the above connection diagrams, danger for the motor and the electric control

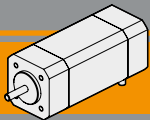
Cavi di segnale Signal leads	Descrizione Description
Blue	HALL fase U U phase HALL
Verde Green	HALL fase V V phase HALL
Bianco White	HALL fase W W phase HALL
Rosso (piccolo) Red (small)	Alimentazione HALL + 5Vcc Supply voltage for Hall sensors, + 5 Vdc
Nero (piccolo) Black (small)	Comune per i segnali di HALL Ground for HALL sensors



BLS043.240

Specifiche costruttive

General features

Tipologia di avvolgimento <i>Winding type</i>	delta	Max forza radiale <i>Max radial force</i>	75N @ 20 mm dalla flangia 75N @ 20 mm from flange
Angolo sensori Hall <i>HALL effect angle</i>	120 gradi elettrici 120 degree electrical angle	Max forza assiale <i>Max axial force</i>	15N
Gioco radiale <i>Radial play</i>	0.025 mm @ 460 g	Classe di isolamento termico <i>Insulation class</i>	Classe B Class B
Gioco assiale <i>End play</i>	0.025 mm @ 4000 g	Isolamento dielettrico <i>Dielectric strength</i>	500Vcc x 1 minuto 500 Vdc 1 minute
Scantatura albero <i>Shaft run out</i>	0.025 mm	Resistenza isolamento <i>Insulation resistance</i>	100MΩ minimo, 500Vcc 100MΩ min, 500 Vdc

Modello <i>Model</i>	Poli <i>Poles</i>	Fasi <i>Phases</i>	Tensione nominale	Velocità nominale	Coppia nominale	Potenza nominale	Coppia di picco	Corrente nominale	Corrente di picco	Resistenza fase-fase	Induttanza fase-fase	Costante di coppia	Costante FCEM	Inerzia rotore	Peso
			<i>Rated voltage</i>	<i>Rated speed</i>	<i>Rated torque</i>	<i>Rated power</i>	<i>Peak torque</i>	<i>Rated current</i>	<i>Peak current</i>	<i>Line to line resistance</i>	<i>Line to line inductance</i>	<i>Torque constant</i>	<i>Back EMF</i>	<i>Rotor inertia</i>	<i>Weight</i>
			[V]	[min ⁻¹]	[Nm]	[W]	[Nm]	[A]	[A]	[Ω]	[mH]	[Nm/A]	[V/kRPM]	[gcm ²]	[kg]
BLS043.240	4	3	36	4000	0.43	180	1.27	6.8	20.5	0.35	1.0	0.063	6.6	230	1.25
BLS043.240	4	3	24	3000	0.43	130	1.27	6.8	20.5	0.35	1.0	0.063	6.6	230	1.25



Prestazioni

Performances

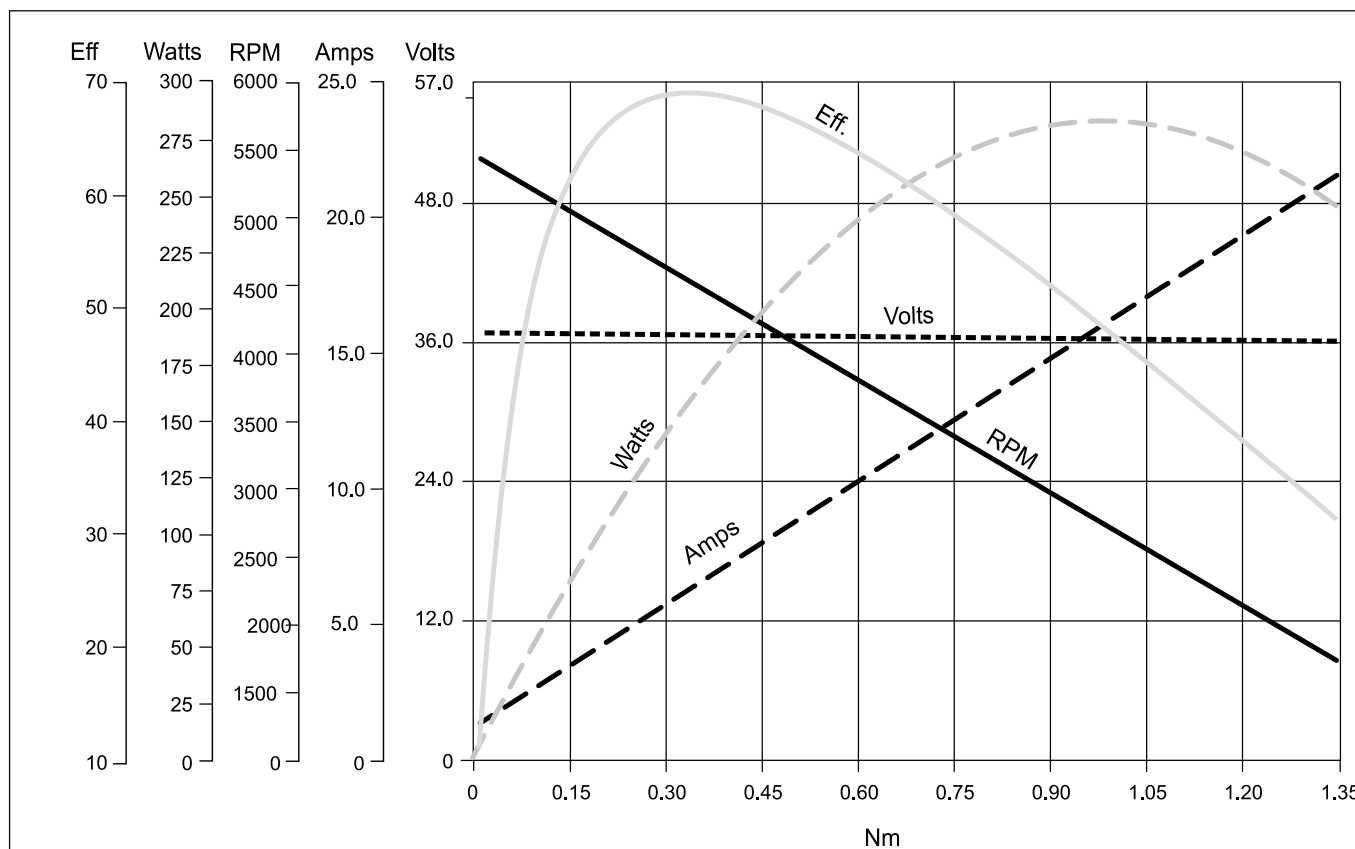

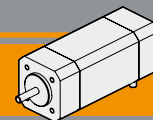
BLS043.240
Dimensioni
Dimensions
BLS043.240

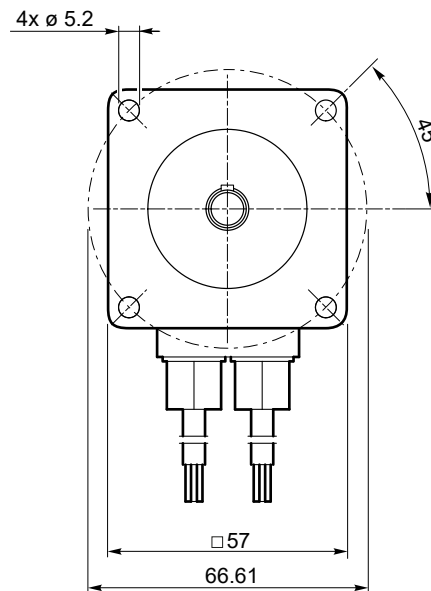
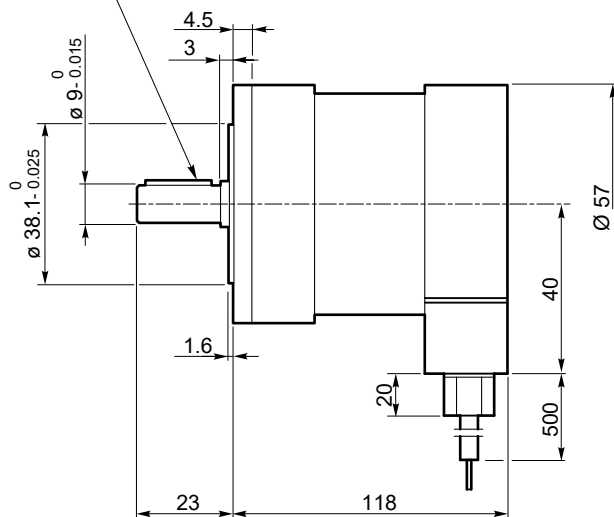
 Linguetta 3x3x16
 DIN 6885
 Key 3x3x16
 DIN 6885

Diagramma dei collegamenti
Connection diagram

Cavi di potenza Power leads	Descrizione Description
Giallo / Yellow	Fase U / U motor Phase
Rosso / Red	Fase V / V motor Phase
Nero / Black	Fase W / W motor Phase

Nota: Si raccomanda di seguire fedelmente gli schemi di collegamento qui riportati, pericolo di danneggiamento del motore o dell'elettronica.

Note: Pls, follow strictly the above connection diagrams, danger for the motor and the electric control

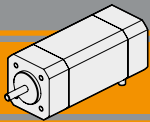
Cavi di segnale Signal leads	Descrizione Description
Blue	HALL fase U U phase HALL
Verde Green	HALL fase V V phase HALL
Bianco White	HALL fase W W phase HALL
Rosso (piccolo) Red (small)	Alimentazione HALL + 5Vcc Supply voltage for Hall sensors, + 5 Vdc
Nero (piccolo) Black (small)	Comune per i segnali di HALL Ground for HALL sensors



BL070.480

Specifiche costruttive

General features

Tipologia di avvolgimento <i>Winding type</i>	Stella <i>Star</i>	Max forza radiale <i>Max radial force</i>	220N @ 20 mm dalla flangia <i>220N @ 20 mm from flange</i>
Angolo sensori Hall <i>HALL effect angle</i>	120 gradi elettrici <i>120 degree electrical angle</i>	Max forza assiale <i>Max axial force</i>	60N
Gioco radiale <i>Radial play</i>	0.02 mm @ 450g	Classe di isolamento termico <i>Insulation class</i>	Classe B <i>Class B</i>
Gioco assiale <i>End play</i>	0.08 mm @ 450g	Isolamento dielettrico <i>Dielectric strength</i>	500Vcc x 1 minuto <i>500 Vdc 1 minute</i>
Scenatura albero <i>Shaft run out</i>	0.05 mm	Resistenza isolamento <i>Insulation resistance</i>	100MΩ minimo, 500Vcc <i>100MΩ min, 500 Vdc</i>

Modello <i>Model</i>	Poli <i>Poles</i>	Fasi <i>Phases</i>	Tensione nominale <i>Rated voltage</i>	Velocità nominale <i>Rated speed</i>	Coppia nominale <i>Rated torque</i>	Potenza nominale <i>Rated power</i>	Coppia di picco <i>Peak torque</i>	Corrente nominale <i>Rated current</i>	Corrente di picco <i>Peak current</i>	Resistenza fase-fase <i>Line to line resistance</i>	Induttanza fase-fase <i>Line to line inductance</i>	Costante di coppia <i>Torque constant</i>	Costante FCEM <i>Back EMF</i>	Inerzia rotore <i>Rotor inertia</i>	Peso <i>Weight</i>
			[V]	[min ⁻¹]	[Nm]	[W]	[Nm]	[A]	[A]	[Ω]	[mH]	[Nm/A]	[V/kRPM]	[gcm ²]	[kg]
BL070.480	8	3	48	3000	0.7	220	2.1	6.5	20	0.34	1.0	0.107	9	800	2.1

Azionamenti
Drives



Prestazioni

Performances

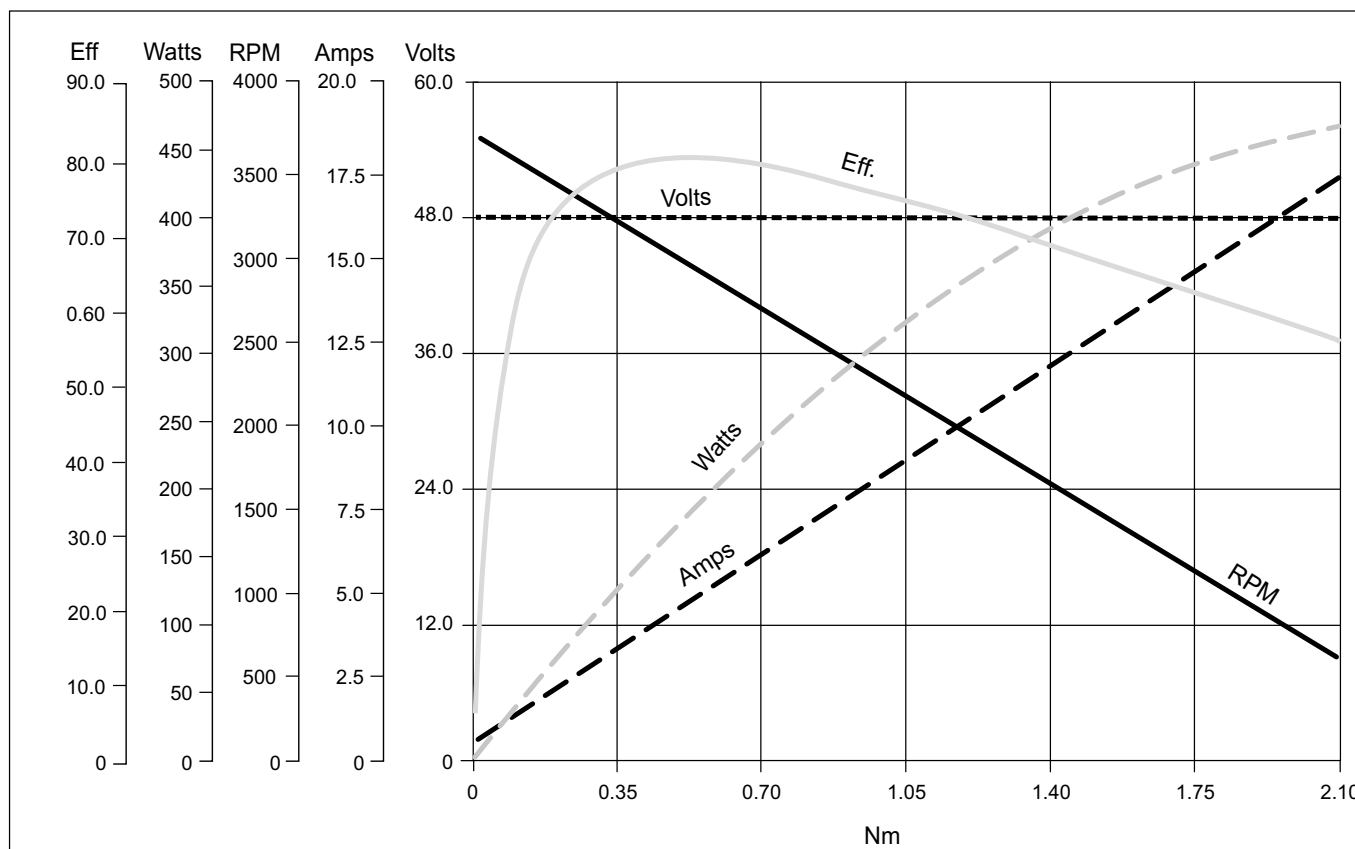

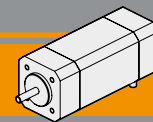
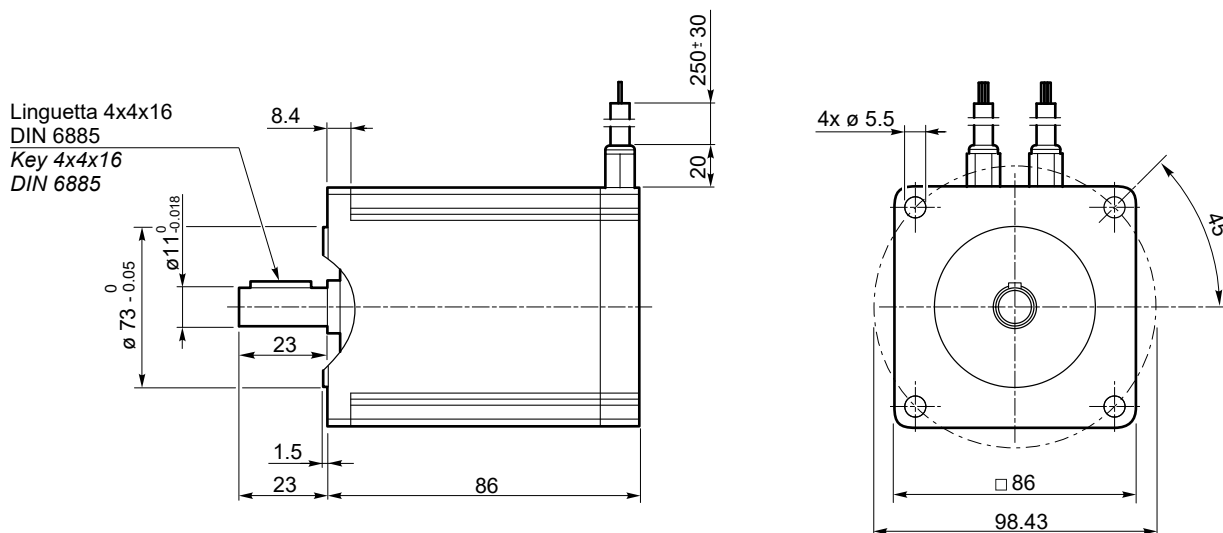

BL070.480
Dimensioni
Dimensions
BL070.480

Diagramma dei collegamenti
Connection diagram

Cavi di potenza Power leads	Descrizione Description
Blu / Blue	Fase U / U motor Phase
Marrone / Brown	Fase V / V motor Phase
Nero / Black	Fase W / W motor Phase

Cavi di segnale Signal leads	Descrizione Description
Blue	HALL fase U U phase HALL
Verde Green	HALL fase V V phase HALL
Bianco White	HALL fase W W phase HALL
Rosso (piccolo) Red (small)	Alimentazione HALL + 5Vcc Supply voltage for Hall sensors, + 5 Vdc
Nero (piccolo) Black (small)	Comune per i segnali di HALL Ground for HALL sensors

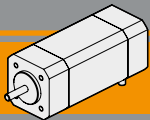
Nota: Si raccomanda di seguire fedelmente gli schemi di collegamento qui riportati, pericolo di danneggiamento del motore o dell'elettronica.

Note: Pls, follow strictly the above connection diagrams, danger for the motor and the electric control



BL140.480

Specifiche costruttive

General features

Tipologia di avvolgimento <i>Winding type</i>	Stella <i>Star</i>	Max forza radiale <i>Max radial force</i>	220N @ 20 mm dalla flangia <i>220N @ 20 mm from flange</i>
Angolo sensori Hall <i>HALL effect angle</i>	120 gradi elettrici <i>120 degree electrical angle</i>	Max forza assiale <i>Max axial force</i>	60N
Gioco radiale <i>Radial play</i>	0.02 mm @ 450g	Classe di isolamento termico <i>Insulation class</i>	Classe B <i>Class B</i>
Gioco assiale <i>End play</i>	0.08 mm @ 450g	Isolamento dielettrico <i>Dielectric strength</i>	500Vcc x 1 minuto <i>500 Vdc 1 minute</i>
Scentratura albero <i>Shaft run out</i>	0.05 mm	Resistenza isolamento <i>Insulation resistance</i>	100MΩ minimo, 500Vcc <i>100MΩ min, 500 Vdc</i>

Modello <i>Model</i>	Poli <i>Poles</i>	Fasi <i>Phases</i>	Tensione nominale	Velocità nominale	Coppia nominale	Potenza nominale	Coppia di picco	Corrente nominale	Corrente di picco	Resistenza fase-fase	Induttanza fase-fase	Costante di coppia	Costante FCEM	Inerzia rotore	Peso
			<i>Rated voltage</i>	<i>Rated speed</i>	<i>Rated torque</i>	<i>Rated power</i>	<i>Peak torque</i>	<i>Rated current</i>	<i>Peak current</i>	<i>Line to line resistance</i>	<i>Line to line inductance</i>	<i>Torque constant</i>	<i>Back EMF</i>	<i>Rotor inertia</i>	<i>Weight</i>
			[V]	[min ⁻¹]	[Nm]	[W]	[Nm]	[A]	[A]	[Ω]	[mH]	[Nm/A]	[V/kRPM]	[gcm ²]	[kg]
BL140.480	8	3	48	3000	1.4	440	4.2	13	37	0.16	0.5	0.113	9.4	1600	3.15



Prestazioni

Performances

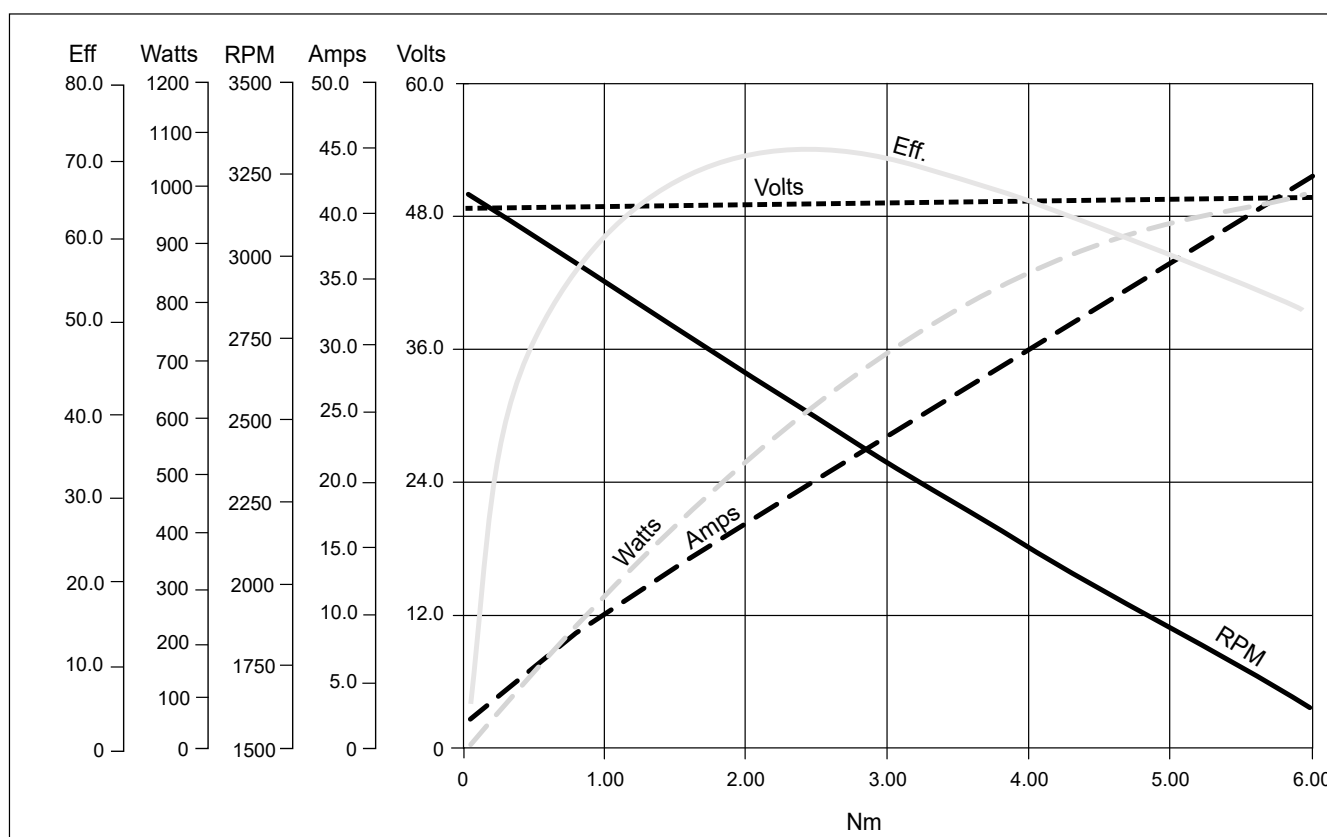

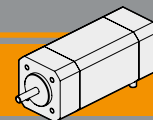
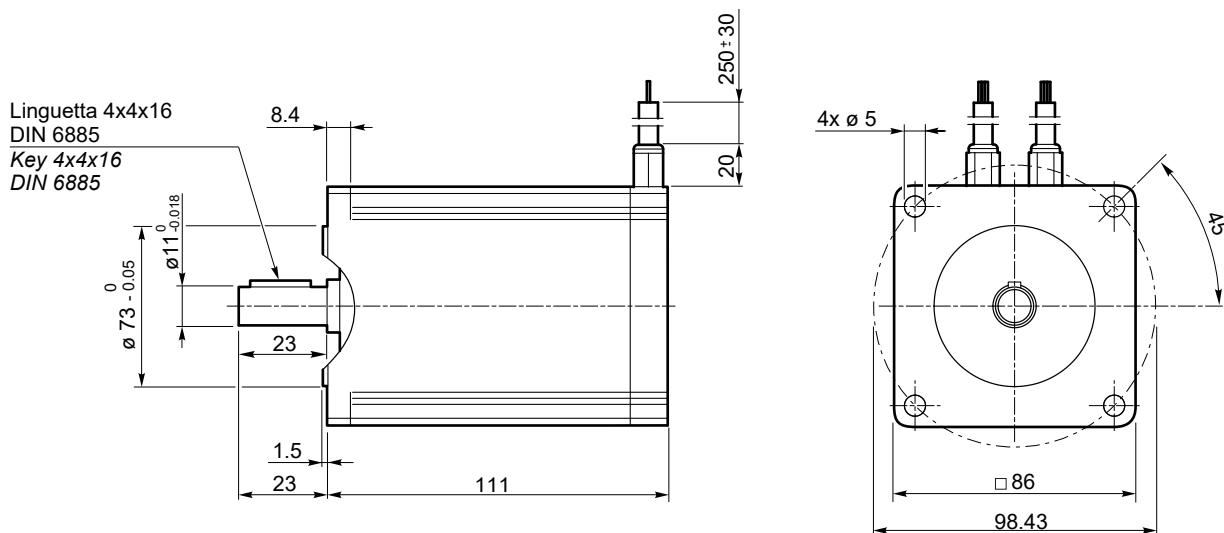

BL140.480
Dimensioni
Dimensions
BL140.480

Diagramma dei collegamenti
Connection diagram

Cavi di potenza Power leads	Descrizione Description
Blu / Blue	Fase U / U motor Phase
Marrone / Brown	Fase V / V motor Phase
Nero / Black	Fase W / W motor Phase

Cavi di segnale Signal leads	Descrizione Description
Blue	HALL fase U U phase HALL
Verde Green	HALL fase V V phase HALL
Bianco White	HALL fase W W phase HALL
Rosso (piccolo) Red (small)	Alimentazione HALL + 5Vcc Supply voltage for Hall sensors, + 5 Vdc
Nero (piccolo) Black (small)	Comune per i segnali di HALL Ground for HALL sensors

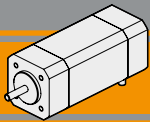
Nota: Si raccomanda di seguire fedelmente gli schemi di collegamento qui riportati, pericolo di danneggiamento del motore o dell'elettronica.

Note: Pls, follow strictly the above connection diagrams, danger for the motor and the electric control



BL210.480

Specifiche costruttive

General features

Tipologia di avvolgimento <i>Winding type</i>	Stella <i>Star</i>	Max forza radiale <i>Max radial force</i>	220N @ 20 mm dalla flangia <i>220N @ 20 mm from flange</i>
Angolo sensori Hall <i>HALL effect angle</i>	120 gradi elettrici <i>120 degree electrical angle</i>	Max forza assiale <i>Max axial force</i>	60N
Gioco radiale <i>Radial play</i>	0.02 mm @ 450g	Classe di isolamento termico <i>Insulation class</i>	Classe B <i>Class B</i>
Gioco assiale <i>End play</i>	0.08 mm @ 450g	Isolamento dielettrico <i>Dielectric strength</i>	500Vcc x 1 minuto <i>500 Vdc 1 minute</i>
Scentratura albero <i>Shaft run out</i>	0.05 mm	Resistenza isolamento <i>Insulation resistance</i>	100MΩ minimo, 500Vcc <i>100MΩ min, 500 Vdc</i>

Modello <i>Model</i>	Poli <i>Poles</i>	Fasi <i>Phases</i>	Tensione nominale	Velocità nominale	Coppia nominale	Potenza nominale	Coppia di picco	Corrente nominale	Corrente di picco	Resistenza fase-fase	Induttanza fase-fase	Costante di coppia	Costante FCEM	Inerzia rotore	Peso
			<i>Rated voltage</i>	<i>Rated speed</i>	<i>Rated torque</i>	<i>Rated power</i>	<i>Peak torque</i>	<i>Rated current</i>	<i>Peak current</i>	<i>Line to line resistance</i>	<i>Line to line inductance</i>	<i>Torque constant</i>	<i>Back EMF</i>	<i>Rotor inertia</i>	<i>Weight</i>
			[V]	[min ⁻¹]	[Nm]	[W]	[Nm]	[A]	[A]	[Ω]	[mH]	[Nm/A]	[V/kRPM]	[gcm ²]	[kg]
BL210.480	8	3	48	3000	2.1	660	6.3	18.7	56	0.115	0.31	0.112	9.5	2400	4.2



Prestazioni

Performances

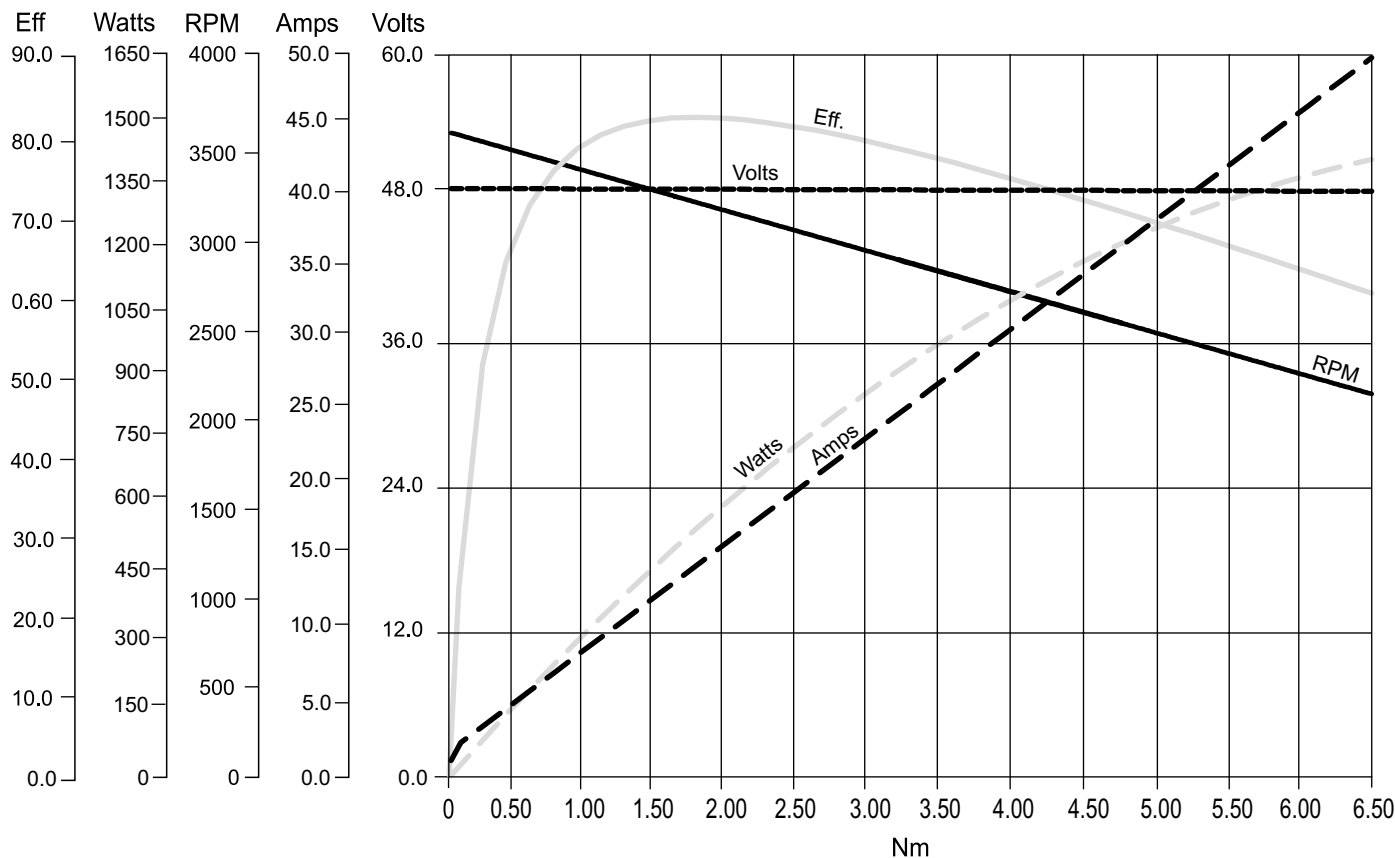

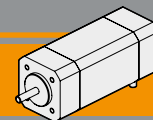
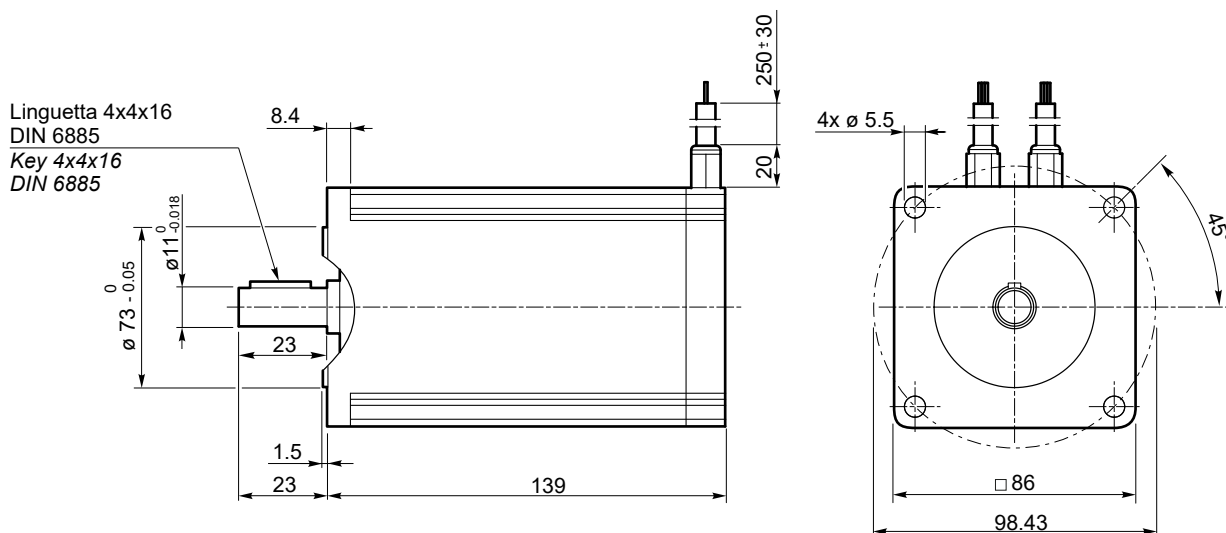
BL210.480
Dimensioni
Dimensions
BL210.480

Diagramma dei collegamenti
Connection diagram

Cavi di potenza Power leads	Descrizione Description
Blu / Blue	Fase U / U motor Phase
Marrone / Brown	Fase V / V motor Phase
Nero / Black	Fase W / W motor Phase

Cavi di segnale Signal leads	Descrizione Description
Blue	HALL fase U U phase HALL
Verde Green	HALL fase V V phase HALL
Bianco White	HALL fase W W phase HALL
Rosso (piccolo) Red (small)	Alimentazione HALL + 5Vcc Supply voltage for Hall sensors, + 5 Vdc
Nero (piccolo) Black (small)	Comune per i segnali di HALL Ground for HALL sensors

Nota: Si raccomanda di seguire fedelmente gli schemi di collegamento qui riportati, pericolo di danneggiamento del motore o dell'elettronica.

Note: Pls, follow strictly the above connection diagrams, danger for the motor and the electric control

Motoriduttori brushless CC ad assi ortogonali
Brushless DC helical bevel gearmotors

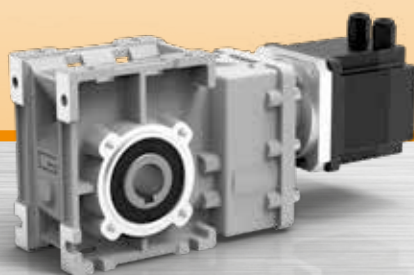

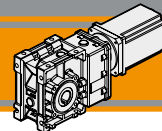

Indice	Index	Pag. Page
Caratteristiche tecniche	<i>Technical features</i>	CB2
Designazione	<i>Classification</i>	CB2
Simbologia	<i>Symbols</i>	CB3
Lubrificazione e temperatura	<i>Lubrication and temperature</i>	CB3
Carichi radiali	<i>Radial loads</i>	CB3
CMB402 con motore brushless BLS043.240	<i>CMB402 with BLS043.240 brushless motor</i>	CB4
CMB402 con motore brushless BL070.480	<i>CMB402 with BL070.480 brushless motor</i>	CB5
CMB402 con motore brushless BL140.480	<i>CMB402 with BL140.480 brushless motor</i>	CB6
Dati tecnici	<i>Technical data</i>	CB7
Dimensioni CMB con flange motore AS	<i>CMB dimensions with motor flanges AS</i>	CB8
Flange uscita	<i>Output flange</i>	CB9
Accessori	<i>Accessories</i>	CB10

Questa sezione annulla e sostituisce ogni precedente edizione o revisione. Qualora questa sezione non Vi sia giunta in distribuzione controllata, l'aggiornamento dei dati ivi contenuto non è assicurato. **In tal caso la versione più aggiornata è disponibile sul nostro sito internet www.transtecno.com**

This section replaces any previous edition and revision. If you obtained this catalogue other than through controlled distribution channels, the most up to date content is not guaranteed. In this case the latest version is available on our web site www.transtecno.com

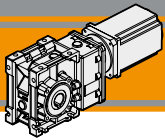

Caratteristiche tecniche

Technical features

Le caratteristiche principali dei motoriduttori brushless CC ad assi ortogonali della serie BLCMB sono:

The main features of BLCMB brushless DC helical bevel gearmotors range are:

- Alimentazione in bassa tensione 24/36/48 Vcc
- Motore Brushless CC con grado di protezione IP55
- Coppie motori disponibili da 0.43 Nm a 1.4 Nm
- Lubrificazione permanente con olio sintetico
- Carcassa in pressofusione di alluminio
- Ingranaggi cilindrici a denti elicoidali, induriti e rettificati
- Disponibili anche nella versione con solo riduttore, sia con flangia di entrata standard che con flangia e manicotto dedicati

- Low voltage power supply 24/36/48 Vdc
- Brushless DC motor in IP55 protection Standard
- Motor torque ratings available from 0.43 Nm up to 1.4 Nm
- Permanent synthetic oil long life lubrication
- Die-cast aluminium housing
- Ground-hardened helical gears.
- Gearbox only version also available, with either standard input flange or customized flange and coupling

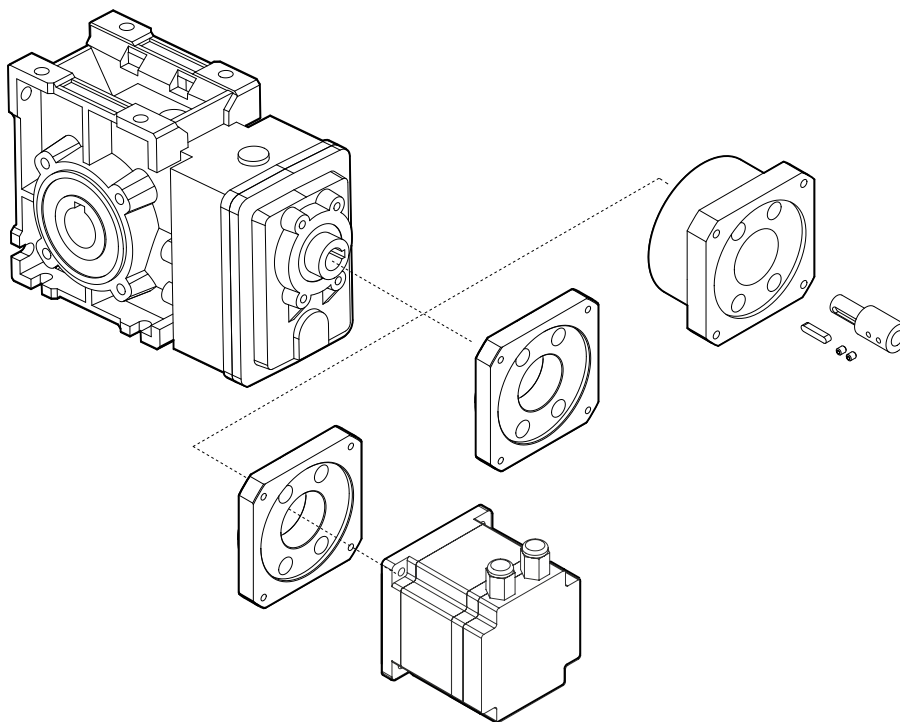

Designazione

Classification

RIDUTTORE / GEARBOX					MOTORE / MOTOR	
CMB	402	U	9.2	020	BL070.480	48V
Tipo Type	Grandezza Size	Versione riduttore Gearbox version	Rapporto Ratio	Albero di uscita Output shaft	Tipo Type	Tensione Voltage
CMB	402	U FD FS FLD FLS FBD FBS	Vedere tabelle See tables		BLS043.240 BL070.480 BL140.480	24V - 36V 48V 48V

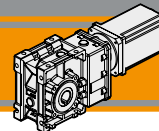

Simbologia

Symbols

Ns	n° stadi / No. stages	Mn ₂	[Nm]	Coppia nominale in uscita in funzione di Pn1 Nominal output torque referred to Pn1
ir	rapporto reale / real ratio	n _{1MAX}	[Rpm]	Velocità max entrata / Max input speed
M ₂	[Nm]	V	[V]	Tensione / Voltage
A ₂	[N]	n ₂	[Rpm]	Velocità in uscita / Output Speed
R ₂	[N]	IP		Grado di protezione / Enclosure protection
Pn ₁	[kW]	Kg		Peso / Weight
		sf		Fattore di servizio / Service Factor

Lubrificazione e temperatura

Lubrication and temperature

I motoriduttori BLCMB sono forniti completi di lubrificante sintetico (viscosità 320) e non necessitano di manutenzione.
Temperatura ambiente 0 ÷ 40 °C (in assenza di congelamento ed in assenza di condensa).
Per temperature diverse, contattare nostro UT.

Permanent synthetic oil long life lubrication (viscosity grade 320) on BLCMB gearmotors.
Ambient temperature 0 ÷ 40 °C (in the absence of freezing and condensation).
For temperature outside this range please contact our technical dept.

Carichi radiali

Radial loads

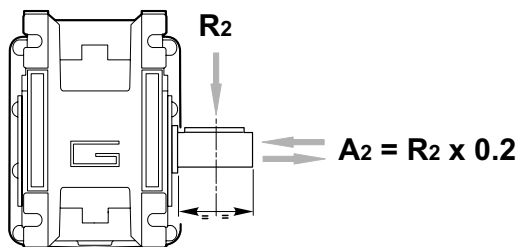

n ₂ [min ⁻¹]	R ₂ [N]
	CMB 402
400	905
300	996
200	1141
170	1204
140	1414
100	1582
90	1638
60	2047
40	2524
30	2778
20	3180
15	3500
10	3500

Quando il carico radiale risultante non è applicato sulla mezzeria dell'albero occorre calcolare quello effettivo con la seguente formula

When the resulting radial load is not applied on the centre line of the shaft it is necessary to calculate the effective load with the following formula:

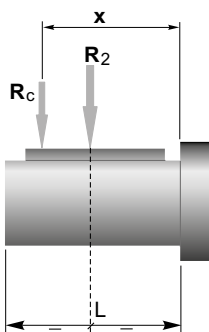

	CMB 402
a	86
b	66
R _{2MAX}	3500

$$R_c = \frac{R_2 \cdot a}{(b + x)} \leq R_{2MAX}$$

$$R \leq R_c$$

a. b = valori riportati nella tabella
a. b = values given in the table

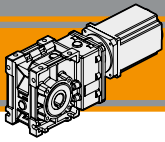

CMB402 con motore brushless

CMB402 with brushless motor

CMB402	BLS043.240													
	24V						36V							
	ir	n ₂ MIN [rpm]			n ₂ MAX [rpm]			n ₁ MAX [rpm]	n ₂ MIN [rpm]			n ₂ MAX [rpm]		n ₁ MAX [rpm]
M ₂ [Nm]		sf		M ₂ [Nm]	sf		M ₂ [Nm]		sf		M ₂ [Nm]	sf		
6.2	49	2.5	18.4	486	2.5	12.5	3000	65	2.5	18.4	648	2.5	11.1	4000
7.5	40	3.0	15.2	400	3.0	10.3		53	3.0	15.2	534	3.0	9.1	
9.2	33	3.7	12.4	326	3.7	8.4		43	3.7	12.4	435	3.7	7.4	
11.8	25	4.8	10.8	254	4.8	7.3		34	4.8	10.8	338	4.8	6.5	
12.5	24	5.0	10.3	240	5.0	7.0		32	5.0	10.3	320	5.0	6.2	
14.8	20	6.0	8.6	202	6.0	5.9		27	6.0	8.6	270	6.0	5.2	
17.6	17	7.1	7.3	170	7.1	4.9		23	7.1	7.3	227	7.1	4.4	
18.6	16	7.5	8.4	161	7.5	5.7		22	7.5	8.4	215	7.5	5.0	
22.3	13	9.0	7.0	134	9.0	4.8		18	9.0	7.0	179	9.0	4.2	
23.9	13	9.7	6.5	125	9.7	4.4		17	9.7	6.5	167	9.7	3.9	
28.9	10	12	6.4	104	12	4.3		14	12	6.4	138	12	3.8	
30.8	9.7	12	6.0	97	12	4.1		13	12	6.0	130	12	3.6	
33.6	8.9	14	5.5	89	14	3.7		12	14	5.5	119	14	3.3	
35.6	8.4	14	5.2	84	14	3.5		11	14	5.2	112	14	3.1	
42.8	7.0	17	4.3	70	17	2.9		9.4	17	4.3	94	17	2.6	
55.3	5.4	22	3.3	54	22	2.3		7.2	22	3.3	72	22	2.0	
59.1	5.1	24	3.1	51	24	2.1		6.8	24	3.1	68	24	1.9	
64.3	4.7	26	2.9	47	26	2.0		6.2	26	2.9	62	26	1.7	
72.5	4.1	29	2.6	41	29	1.7		5.5	29	2.6	55	29	1.5	

Tipo Type	Numero di poli Number of poles	Numero di fasi Number of phase	Tensione Rated voltage [V]	Numero di giri Rated speed [rpm]	Coppia nominale Rated torque [Nm]	Potenza nominale Rated power [W]
BLS043.240	4	3	36	4000	0.43	180
			24	3000		130
Tipo Type	Coppia massima Peak torque [Nm]	Corrente nominale Rated current [A]	Resistenza Resistance [ohm]	Induttanza Inductance [mH]	Corrente massima Peak current [A]	Peso Weight [kg]
BLS043.240	0.86	6	0.35	1	12.0	1.25

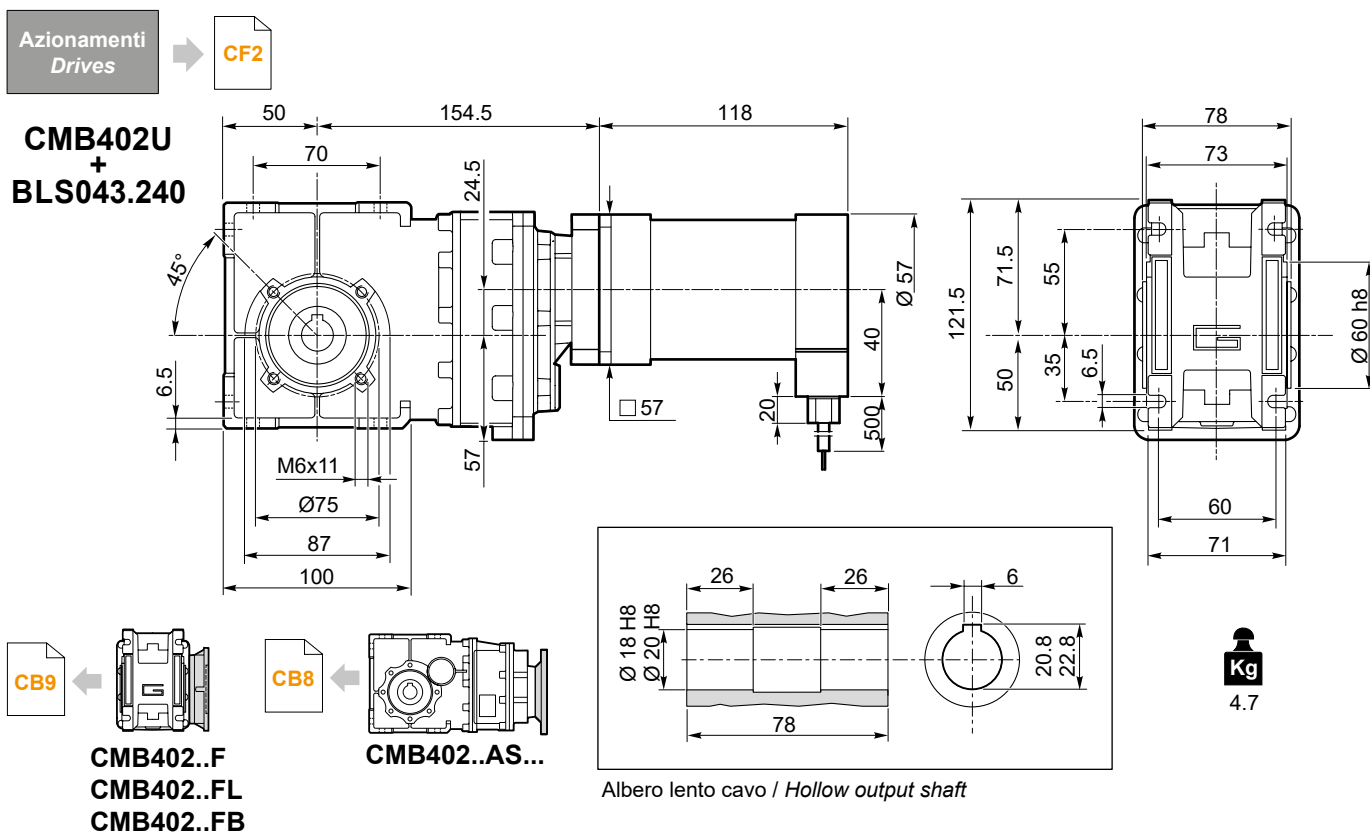

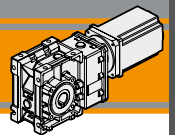

CMB402 con motore brushless

CMB402 with brushless motor

CMB402	BL070.480					
	48V					
	ir	n _{2MIN} [rpm]			n _{2MAX} [rpm]	
M ₂ [Nm]		sf		M ₂ [Nm]	sf	n _{1MAX} [rpm]
6.2	49	4.1	11.3	486	4.1	7.7
7.5	40	4.9	9.3	400	4.9	6.3
9.2	33	6.1	7.6	326	6.1	5.2
11.8	25	7.8	6.6	254	7.8	4.5
12.5	24	8.2	6.3	240	8.2	4.3
14.8	20	9.8	5.3	202	9.8	3.6
17.6	17	12	4.5	170	12	3.0
18.6	16	12	5.2	161	12	3.5
22.3	13	15	4.3	134	15	2.9
23.9	13	16	4.0	125	16	2.7
28.9	10	19	3.9	104	19	2.7
30.8	9.7	20	3.7	97	20	2.5
33.6	8.9	22	3.4	89	22	2.3
35.6	8.4	23	3.2	84	23	2.2
42.8	7.0	28	2.7	70	28	1.8
55.3	5.4	36	2.1	54	36	1.4
59.1	5.1	39	1.9	51	39	1.3
64.3	4.7	42	1.8	47	42	1.2
72.5	4.1	48	1.6	41	48	1.1

Tipo Type	Numero di poli Number of poles	Numero di fasi Number of phase	Tensione Rated voltage [V]	Numero di giri Rated speed [rpm]	Coppia nominale Rated torque [Nm]	Potenza nominale Rated power [W]
BL070.480	8	3	48	3000	0.70	220
Tipo Type	Coppia massima Peak torque [Nm]	Corrente nominale Rated current [A]	Resistenza Resistance [ohm]	Induttanza Inductance [mH]	Corrente massima Peak current [A]	Peso Weight [kg]
BL070.480	1.4	6.5	0.34	1.0	13.0	2.1

Azionamenti
Drives



CMB402U
+
BL070.480

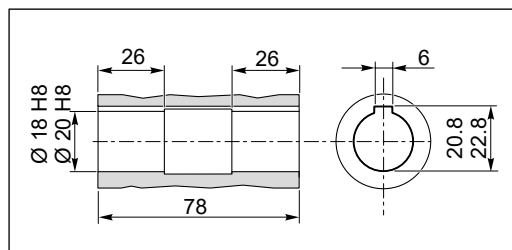
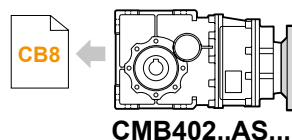
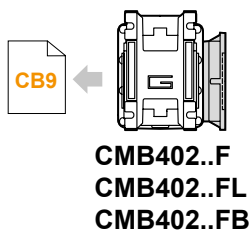
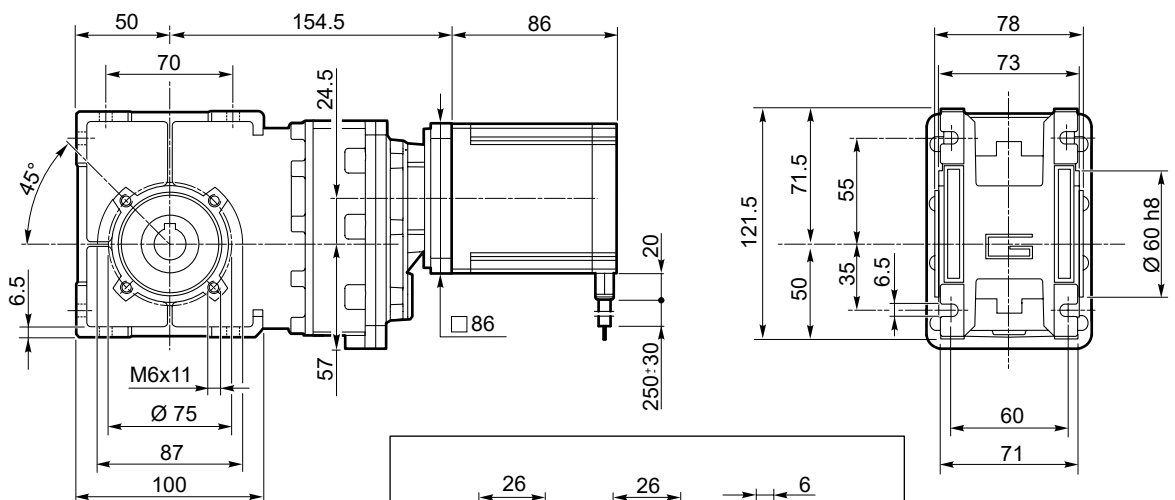

Albero lento cavo / Hollow output shaft



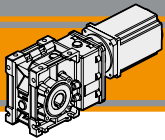

CMB402 con motore brushless

CMB402 with brushless motor

CMB402	BL140.480					
	48V					
	ir	n _{2MIN} [rpm]			n _{2MAX} [rpm]	
M ₂ [Nm]		sf		M ₂ [Nm]	sf	n _{1MAX} [rpm]
6.2	49	8.1	5.7	486	8.1	3.8
7.5	40	9.9	4.7	400	9.9	3.2
9.2	33	12.1	3.8	326	12.1	2.6
11.8	25	15.6	3.3	254	15.6	2.3
12.5	24	16.4	3.1	240	16.4	2.1
14.8	20	19.5	2.7	202	19.5	1.8
17.6	17	23	2.2	170	23	1.5
18.6	16	24	2.6	161	24	1.8
22.3	13	29	2.2	134	29	1.5
23.9	13	31	2.0	125	31	1.4
28.9	10	38	2.0	104	38	1.3
30.8	9.7	41	1.8	97	41	1.2
33.6	8.9	44	1.7	89	44	1.1
35.6	8.4	47	1.6	84	47	1.1
42.8	7.0	56	1.3	70	56	0.9
55.3	5.4	73	1.0	54	72	0.7
59.1	5.1	78	1.0	51	72	0.7
64.3	4.7	85	0.9	47	72	0.7
72.5	4.1	95	0.8	41	72	0.7

Attenzione: superamento della coppia nominale supportata dal riduttore per servizio S1.
Contattare il ns. servizio tecnico
*Attention: rated torque withstood by gear reducer for service in S1 is exceeded.
Please. contact our technical office.*

Tipo Type	Numero di poli Number of poles	Numero di fasi Number of phase	Tensione Rated voltage [V]	Numero di giri Rated speed [rpm]	Coppia nominale Rated torque [Nm]	Potenza nominale Rated power [W]
BL140.480	8	3	48	3000	1.4	440
Tipo Type	Coppia massima Peak torque [Nm]	Corrente nominale Rated current [A]	Resistenza Resistance [ohm]	Induttanza Inductance [mH]	Corrente massima Peak current [A]	Peso Weight [kg]
BL140.480	2.8	13.0	0.16	0.5	26	3.15

Azionamenti Drives

CF5

CMB402U + BL140.480

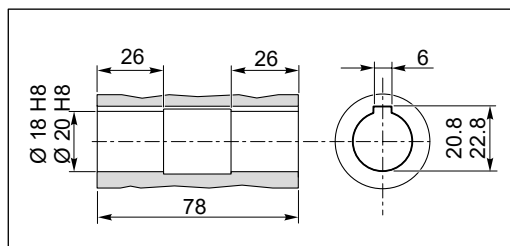
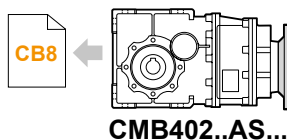
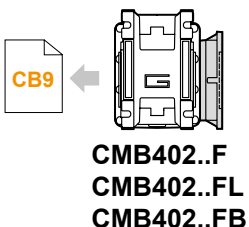
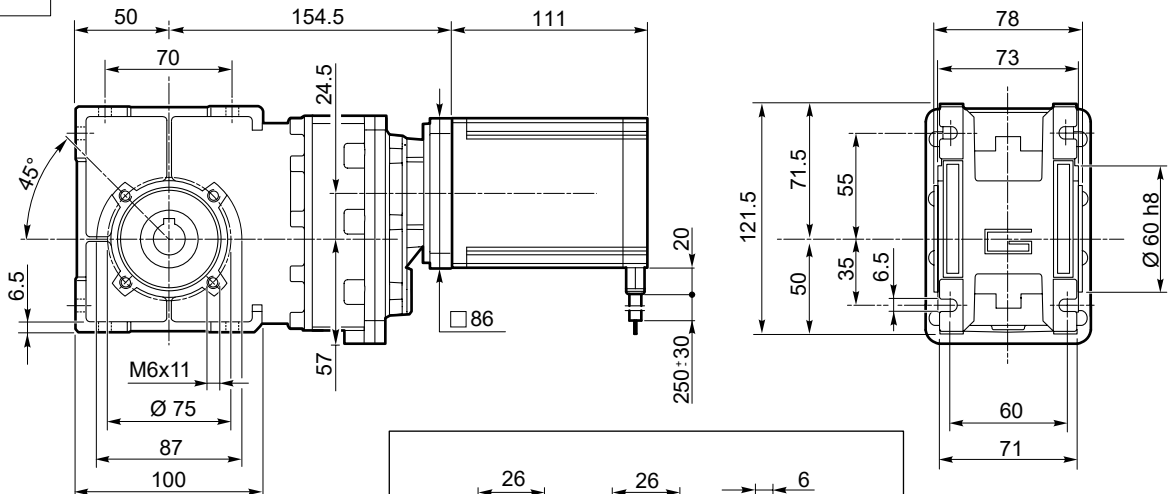

Albero lento cavo / Hollow output shaft

Kg
6.5

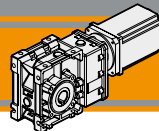

Dati tecnici

Technical data

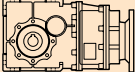
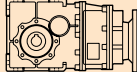
	n_2 [min ⁻¹]	Mn_2 [Nm]	Pn_1 [kW]	i		n_2 [min ⁻¹]	Mn_2 [Nm]	Pn_1 [kW]	i
CMB 402					CMB 402				
$n_1 = 1400$ rpm	227	40	1.0	6.18	$n_1 = 3000$ rpm	486	31.2	1.65	6.18
	187	40	0.83	7.49		400	31.2	1.36	7.49
	152	40	0.68	9.2		326	31.2	1.11	9.20
	118	45	0.59	11.83		254	35.1	0.97	11.83
	112	45	0.56	12.48		240	35.1	0.92	12.48
	94.4	45	0.47	14.83		202	35.1	0.77	14.83
	79.4	45	0.40	17.63		170	35.1	0.65	17.63
	75.3	55	0.46	18.6		161	42.9	0.75	18.60
	62.7	55	0.38	22.33		134	42.9	0.63	22.33
	58.6	55	0.36	23.91		126	42.9	0.59	23.91
	48.5	65	0.35	28.89		104	50.7	0.57	28.89
	45.4	65	0.33	30.84		97.3	50.7	0.54	30.84
	41.7	65	0.30	33.57		89.4	50.7	0.49	33.57
	39.3	65	0.28	35.63		84.2	50.7	0.47	35.63
	32.7	65	0.24	42.75		70.2	50.7	0.39	42.75
	25.3	65	0.18	55.31		54.2	50.7	0.30	55.31
	23.7	65	0.17	59.06		50.8	50.7	0.28	59.06
	21.8	65	0.16	64.29		46.7	50.7	0.26	64.29
	19.3	65	0.14	72.50		41.4	50.7	0.23	72.50

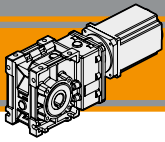

Dimensioni CMB con flange motore AS

CMB dimensions with motor flanges AS

CMB402 - U - AS...

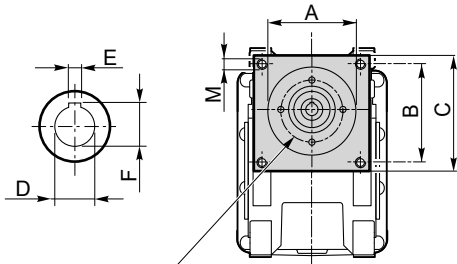

Connessione con boccola o giunto in funzione del diametro dell'albero motore.

Connection with sleeve or coupling depending on motorshaft's diameter.

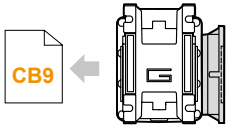

CMB402..F
CMB402..FL
CMB402..FB

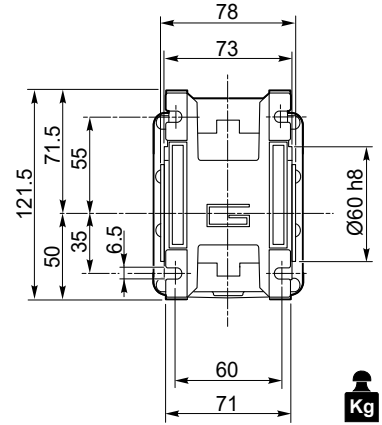
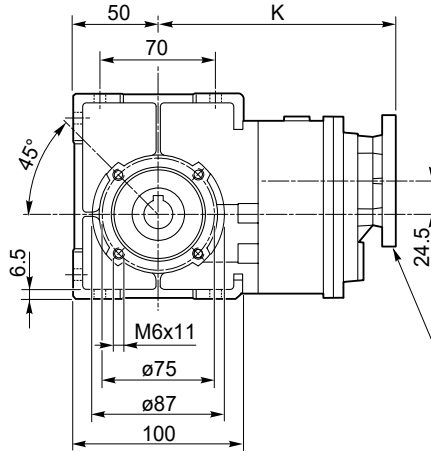

3.4

Lo spessore della flangia è variabile in funzione delle diverse lunghezze dell'albero motore.

Flange's thickness may vary depending on motorshaft's length.

Dimensioni / Dimensions								
AS	A	B	C	M	K	D	E	F
AS392	38.1	47.1	64	M5	154.5	9	3	10.5
						11	4	12.8
						14	5	16.3
AS384	73	69.6	86	M5	154.5	9	3	10.5
						11	4	12.8
						14	5	16.3
...

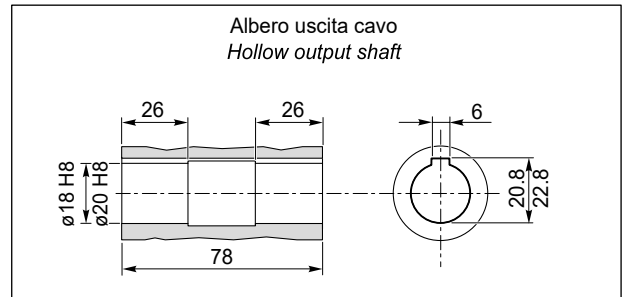

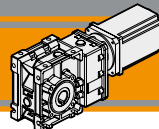

Flange uscita

Output flange

Flange uscita / Output flanges																											
CMB	F										FL										FB						
	a ₁	KA	KB	KC	KM	KN H8	KO	KP	KQ	a ₁	KA	KB	KC	KM	KN H8	KO	KP	KQ	a ₁	KA	KB	KC	KM	KN H8	KO	KP	KQ
402	45°	67	7.5	4.5	80-95	60	9	110	95	45°	97	7.5	4.5	80-95	60	9	110	95	45°	80	8.5	5	115-125	95	9.5	140	112

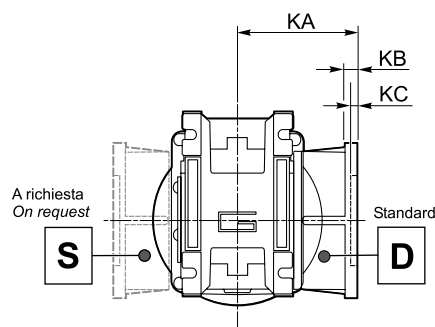
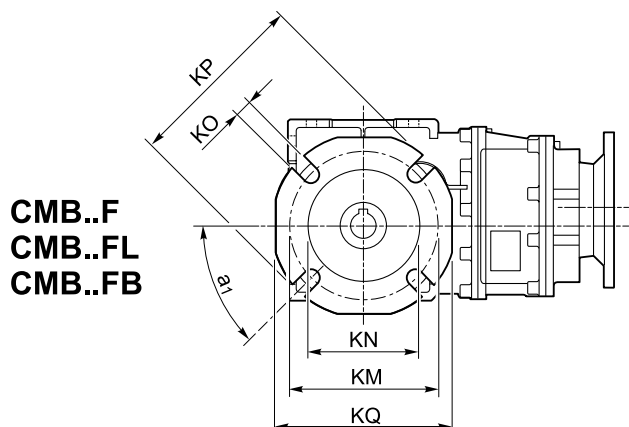

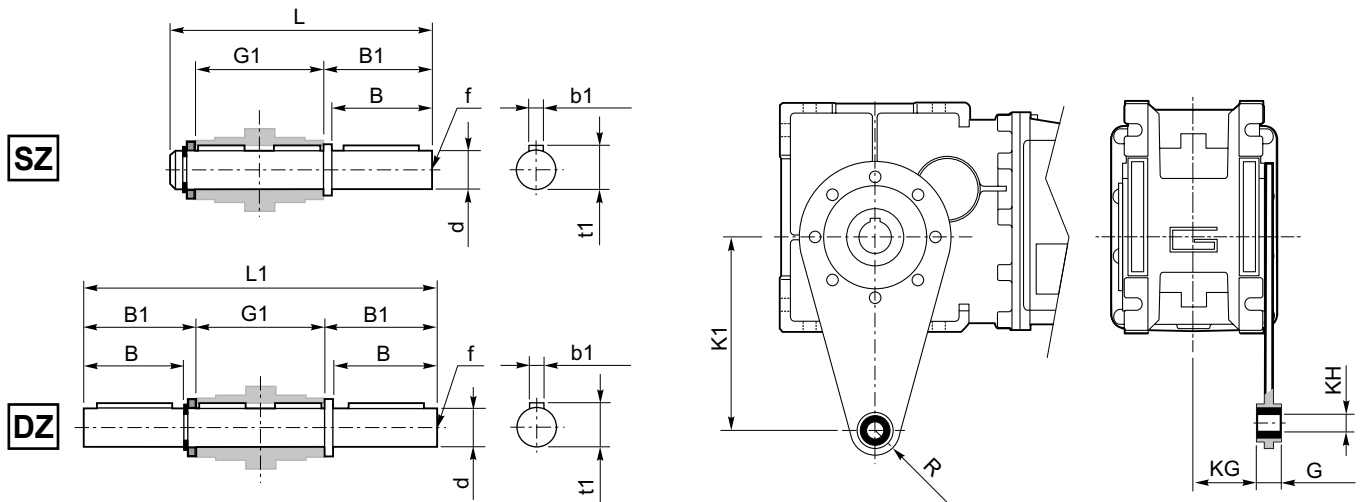
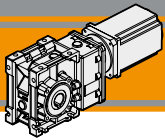

Albero lento / Output shaft

CMB	d h7	B	B1	G1	L	L1	f	b1	t1
402	18	40	43	78	128	164	M6	6	20.5

Braccio di reazione / Torque arm

CMB	K1	G	KG	KH	R
402	100	14	31	10	18

SC - Safety cover

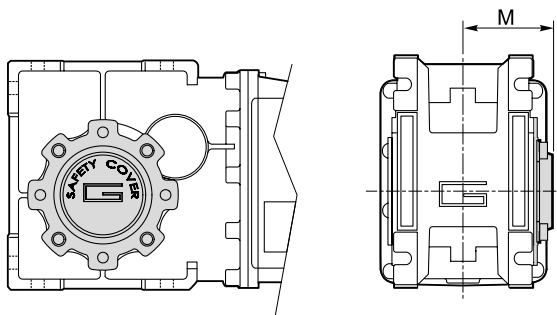

CMB	M
402	54.5

Motoriduttori brushless CC pendolari
Brushless DC helical parallel gearmotors

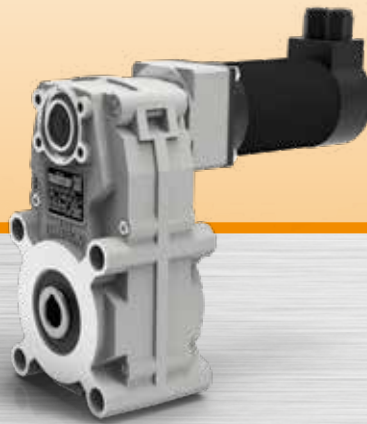

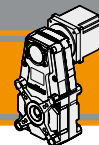

Indice	Index	Pag. Page
Caratteristiche tecniche	<i>Technical features</i>	CC2
Designazione	<i>Classification</i>	CC3
Simbologia	<i>Symbols</i>	CC3
Lubrificazione e temperatura	<i>Lubrication and temperature</i>	CC3
FT105 con motore brushless BLS022.240	<i>FT105 with BLS022.240 brushless motor</i>	CC4
FT105 con motore brushless BLS043.240	<i>FT105 with BLS043.240 brushless motor</i>	CC5
Dati tecnici	<i>Technical data</i>	CC6
Dimensioni FT con flange motore AS	<i>FT dimensions with motor flanges AS</i>	CC6

Questa sezione annulla e sostituisce ogni precedente edizione o revisione. Qualora questa sezione non Vi sia giunta in distribuzione controllata, l'aggiornamento dei dati ivi contenuto non è assicurato. **In tal caso la versione più aggiornata è disponibile sul nostro sito internet www.transtecno.com**

*This section replaces any previous edition and revision. If you obtained this catalogue other than through controlled distribution channels, the most up to date content is not guaranteed. **In this case the latest version is available on our web site www.transtecno.com***

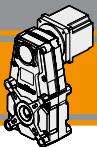

Caratteristiche tecniche

Technical features

Le caratteristiche principali dei motoriduttori brushless CC pendolari della serie BLFT sono:

- Alimentazione in bassa tensione 24/36/48 Vcc
- Motore Brushless CC con grado di protezione IP55
- Coppie motori disponibili da 0.22 Nm a 0.43 Nm
- Lubrificazione permanente con olio sintetico
- Carcassa in pressofusione di alluminio
- Ingranaggi cilindrici a denti elicoidali, induriti e rettificati
- Disponibili anche nella versione con solo riduttore, sia con flangia di entrata standard che con flangia e manicotto dedicati

The main features of BLFT brushless DC helical parallel gearmotors range are:

- Low voltage power supply 24/36/48 Vdc
- Brushless DC motor in IP55 protection Standard
- Motor torque ratings available from 0.22 Nm up to 0.43 Nm
- Permanent synthetic oil long life lubrication
- Die-cast aluminium housing
- Ground-hardened helical gears
- Gearbox only version also available, with either standard input flange or customized flange and coupling

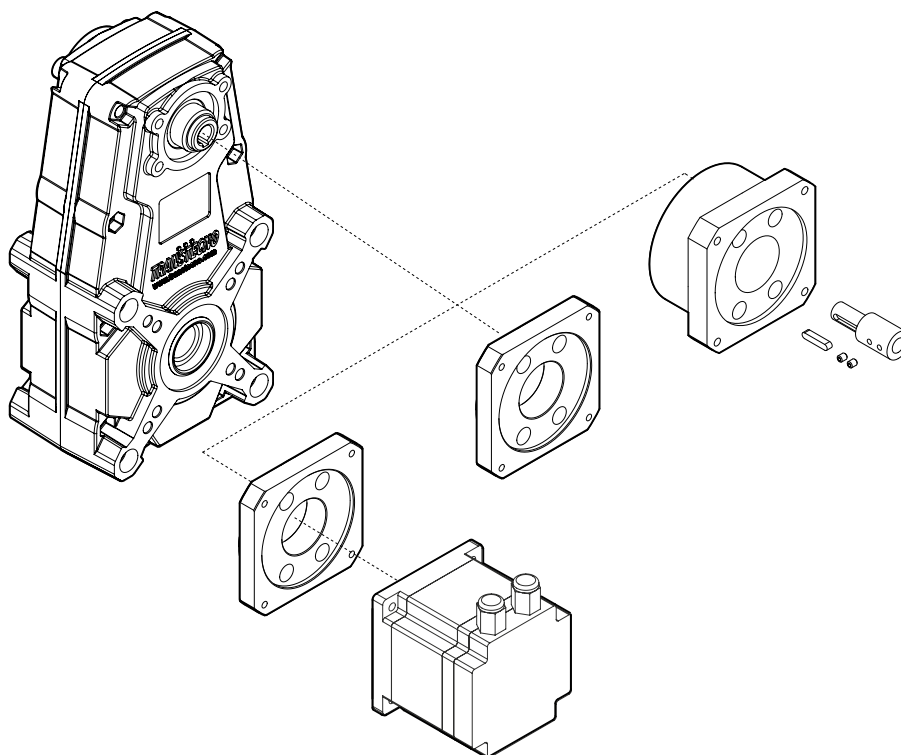

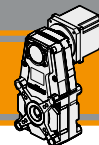

Designazione

Classification

RIDUTTORE / GEARBOX					MOTORE / MOTOR	
FT	105	U	46	020	BL043.240	24V
Tipo Type	Grandezza Size	Versione riduttore Gearbox version	Rapporto Ratio	Albero di uscita Output shaft	Tipo Type	Tensione Voltage
FT	105	U	Vedere tabelle See tables	Vedere tabelle See tables	BLS022.240 BLS043.240	24V - 36V 24V - 36V

Simbologia

Symbols

Ns	n° stadi / No. stages	Mn ₂	[Nm]	Coppia nominale in uscita in funzione di Pn1 Nominal output torque referred to Pn1
ir	rapporto reale / real ratio	n _{1MAX}	[Rpm]	Velocità max entrata / Max input speed
M ₂	[Nm] coppia in uscita output torque	V	[V]	Tensione / Voltage
A ₂	[N] Carico assiale ammissibile in uscita Permitted output axial load	n ₂	[Rpm]	Velocità in uscita / Output Speed
R ₂	[N] Carico radiale ammissibile in uscita Permitted output radial load	IP		Grado di protezione / Enclosure protection
Pn ₁	[kW] Potenza nominale in entrata Nominal input power	Kg		Peso / Weight
		sf		Fattore di servizio / Service Factor

Lubrificazione e temperatura

Lubrication and temperature

I motoriduttori BLFT sono forniti completi di lubrificante sintetico (viscosità 320) e non necessitano di manutenzione.
Temperatura ambiente 0 ÷ 40 °C (in assenza di congelamento ed in assenza di condensa).
Per temperature diverse, contattare nostro UT.

Permanent synthetic oil long life lubrication (viscosity grade 320) on BLFT gearmotors.
Ambient temperature 0 ÷ 40 °C (in the absence of freezing and condensation).
For temperature outside this range please contact our technical dept.



FT105 con motore brushless

FT105 with brushless motor

FT105		BLS022.240													
		24V							36V						
		ir	Ns	n _{2MIN} [rpm]			n _{2MAX} [rpm]			n _{1MAX} [rpm]	n _{2MIN} [rpm]			n _{2MAX} [rpm]	
M ₂ [Nm]	sf			M ₂ [Nm]	sf		M ₂ [Nm]	sf			M ₂ [Nm]	sf			
20.6	3	14.6	4.3	10.8	146	4.3	7.3	3000	19.4	4.3	10.8	194	4.3	6.5	4000
33.3		9.0	6.9	8.3	90	6.9	5.7		12.0	6.9	8.3	120	6.9	5.0	
44.4		6.8	9.2	8.1	68	9.2	5.5		9.0	9.2	8.1	90	9.2	4.9	
54.9		5.5	11	6.6	55	11	4.5		7.3	11	6.6	73	11	4.0	
71.8		4.2	15	5.0	42	15	3.4		5.6	15	5.0	56	15	3.0	
77.1		3.9	16	4.7	39	16	3.2		5.2	16	4.7	52	16	2.8	
88.9		3.4	18	4.1	34	18	2.8		4.5	18	4.1	45	18	2.4	
124.8		2.4	26	2.9	24	26	2.0		3.2	26	2.9	32	26	1.7	
181.4		1.7	38	2.0	17	38	1.4		2.2	38	2.0	22	38	1.2	
224.3		1.3	46	1.6	13	46	1.1		1.8	46	1.6	18	46	1.0	
315.1		1.0	65	1.1	10	65	0.8		1.3	65	1.1	13	64	0.7	
368.2		0.8	75	1.0	8.1	72	0.7		1.1	75	1.0	11	64	0.7	
535.0	0.6	105	0.7	5.6	72	0.7	0.7	105	0.7	7.5	64	0.7			
661.8	0.5	105	0.7	4.5	72	0.7	0.6	105	0.7	6.0	64	0.7			
929.4	0.3	105	0.7	3.2	72	0.7	0.4	105	0.7	4.3	64	0.7			

Attenzione: superamento della coppia nominale supportata dal riduttore per servizio S1. Contattare il ns. servizio tecnico
Attention: rated torque withstood by gear reducer for service in S1 is exceeded. Please, contact our technical office.

Tipo Type	Numero di poli Number of poles	Numero di fasi Number of phase	Tensione Rated voltage [V]	Numero di giri Rated speed [rpm]	Coppia nominale Rated torque [Nm]	Potenza nominale Rated power [W]
BLS022.240	4	3	36	4000	0.22	92
			24	3000		70
Tipo Type	Coppia massima Peak torque [Nm]	Corrente nominale Rated current [A]	Resistenza Resistance [ohm]	Induttanza Inductance [mH]	Corrente massima Peak current [A]	Peso Weight [kg]
BLS022.240	0.44	3.7	0.64	3.1	7.4	0.72

Azionamenti Drives

CF2

FT105U + BLS022.240

CC6

FT105.. AS...

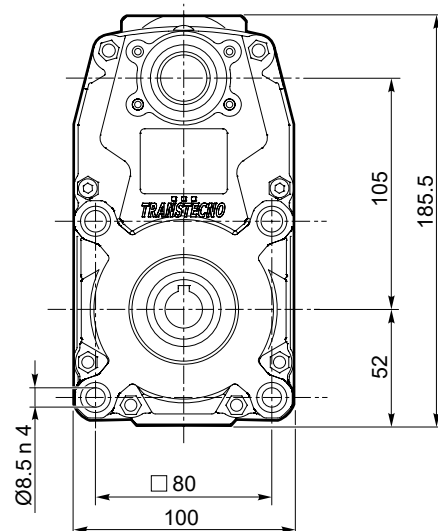
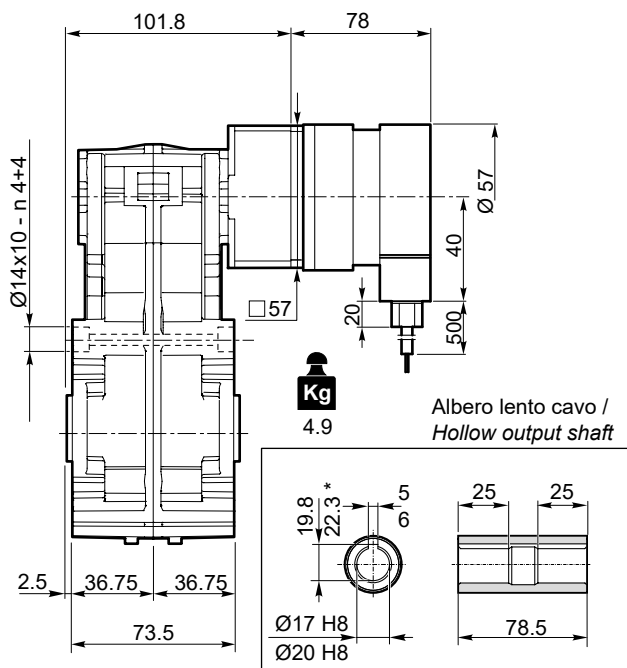

*Sede linguetta ribassata /
*Special keyway

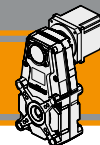

FT105 con motore brushless

FT105 with brushless motor

FT105		BLS043.240													
		24V							36V						
		ir	Ns	n _{2MIN} [rpm]			n _{2MAX} [rpm]			n _{1MAX} [rpm]	n _{2MIN} [rpm]			n _{2MAX} [rpm]	
M ₂ [Nm]	sf				M ₂ [Nm]	sf		M ₂ [Nm]	sf			M ₂ [Nm]	sf		
20.6	3	14.6	8.3	5.5	146	8.3	3.8	3000	19.4	8.3	5.5	194	8.3	3.3	4000
33.3		9.0	13	4.3	90	13	2.9		12.0	13	4.3	120	13	2.6	
44.4		6.8	18	4.2	68	18	2.8		9.0	18	4.2	90	18	2.5	
54.9		5.5	22	3.4	55	22	2.3		7.3	22	3.4	73	22	2.0	
71.8		4.2	29	2.6	42	29	1.7		5.6	29	2.6	56	29	1.5	
77.1		3.9	31	2.4	39	31	1.6		5.2	31	2.4	52	31	1.4	
88.9		3.4	36	2.1	34	36	1.4		4.5	36	2.1	45	36	1.2	
124.8		2.4	50	1.5	24	50	1.0		3.2	50	1.5	32	50	0.9	
181.4		1.7	73	1.0	17	72	0.7		2.2	73	1.0	22	64	0.7	
224.3		1.3	91	0.8	13	72	0.7		1.8	91	0.8	18	64	0.7	
315.1		1.0	105	0.7	10	72	0.7		1.3	105	0.7	13	64	0.7	
368.2		4	0.8	105	0.7	8.1	72		0.7	1.1	105	0.7	11	64	
535.0	0.6		105	0.7	5.6	72	0.7	0.7	105	0.7	7.5	64	0.7		
661.8	0.5		105	0.7	4.5	72	0.7	0.6	105	0.7	6.0	64	0.7		
929.4	0.3		105	0.7	3.2	72	0.7	0.4	105	0.7	4.3	64	0.7		

Attenzione: superamento della coppia nominale supportata dal riduttore per servizio S1. Contattare il ns. servizio tecnico
Attention: rated torque withstood by gear reducer for service in S1 is exceeded. Please, contact our technical office.

Tipo Type	Numero di poli Number of poles	Numero di fasi Number of phase	Tensione Rated voltage [V]	Numero di giri Rated speed [rpm]	Coppia nominale Rated torque [Nm]	Potenza nominale Rated power [W]
BLS043.240	4	3	36	4000	0.43	180
			24	3000		130
Tipo Type	Coppia massima Peak torque [Nm]	Corrente nominale Rated current [A]	Resistenza Resistance [ohm]	Induttanza Inductance [mH]	Corrente massima Peak current [A]	Peso Weight [kg]
BLS043.240	0.86	6	0.35	1	12.0	1.25

Azionamenti Drives

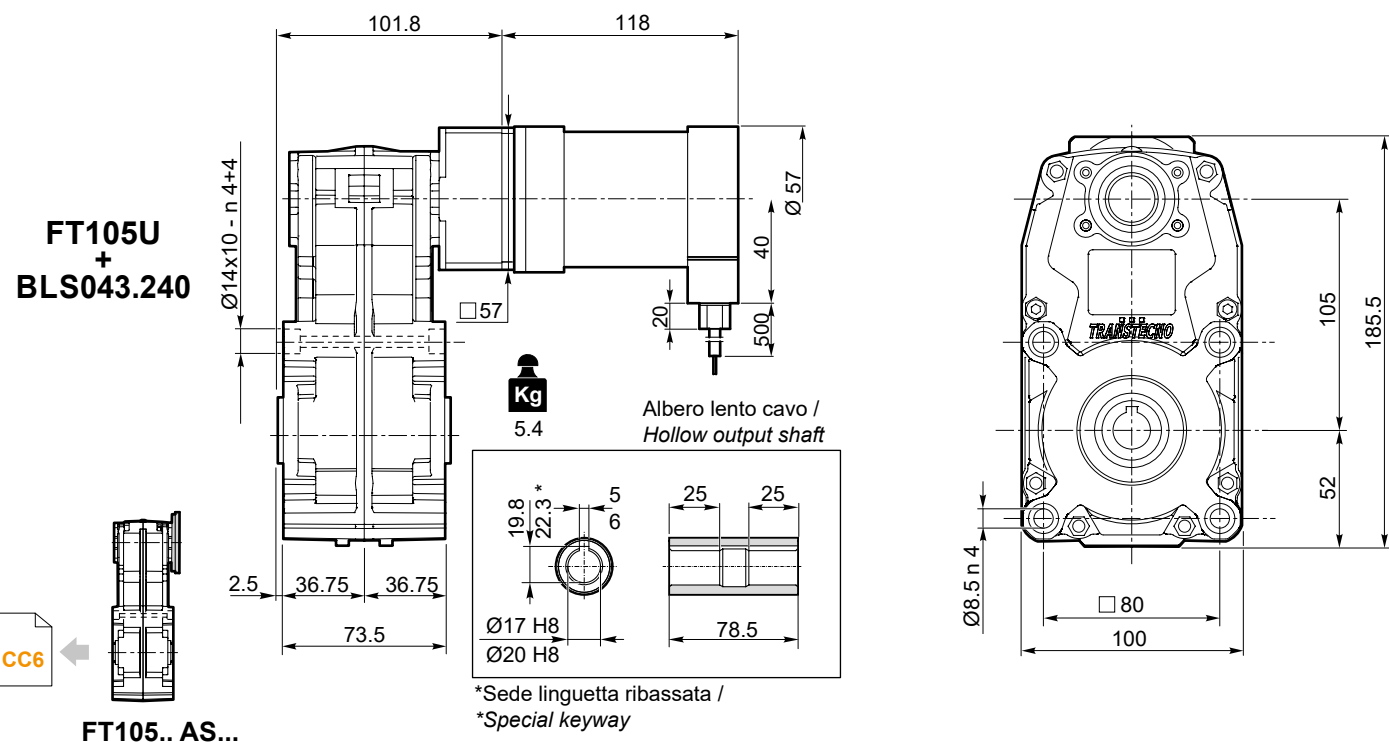

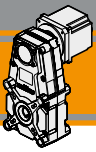

FT105.. AS...



Dati tecnici

Technical data

	n_2 [min ⁻¹]	Mn_2 [Nm]	Pn_1 [kW]	i		n_2 [min ⁻¹]	Mn_2 [Nm]	Pn_1 [kW]	i		
FT105					FT105						
FT105/3	$n_1 = 1400$ rpm	68	40	0.30	20.57	FT105/3	$n_1 = 3000$ rpm	146	31	0.51	20.57
		42	50	0.23	33.32			90	39	0.39	33.32
		32		0.23	44.36			68		0.38	44.36
		26		0.18	54.87			55		0.31	54.87
		20		0.14	71.84			42		0.24	71.84
		18		0.13	77.07			39		0.22	77.07
		16	65	0.11	88.87			34	51	0.19	88.87
		11		0.081	124.81			24		0.14	124.81
		7.7		0.056	181.35			17		0.09	181.35
		6.2		0.045	224.32			13		0.08	224.32
	4.4		0.032	315.05		10		0.05	315.05		
FT105/4		3.8	65	0.028	368.19	FT105/4		8.1	51	0.05	368.19
		2.6		0.019	534.98			5.6		0.03	534.98
		2.1		0.015	661.76			4.5		0.03	661.76
		1.5		0.011	929.40			3.2		0.02	929.40

Dimensioni FT con flange motore AS

FT dimensions with motor flanges AS

FT105 - U - AS...

Lo spessore della flangia è variabile in funzione delle diverse lunghezze dell'albero motore.

Flange's thickness may vary depending on motor shaft's length.

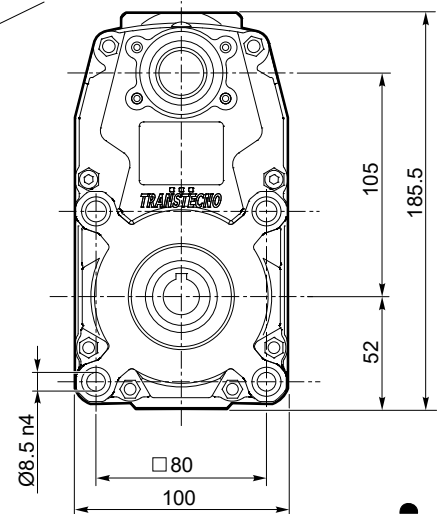
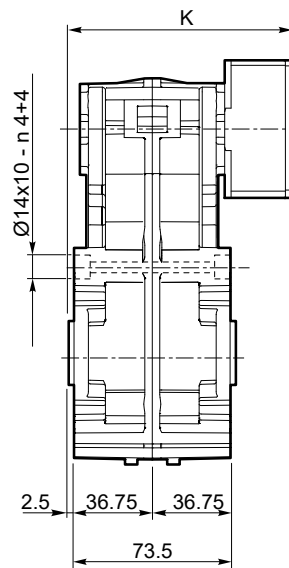
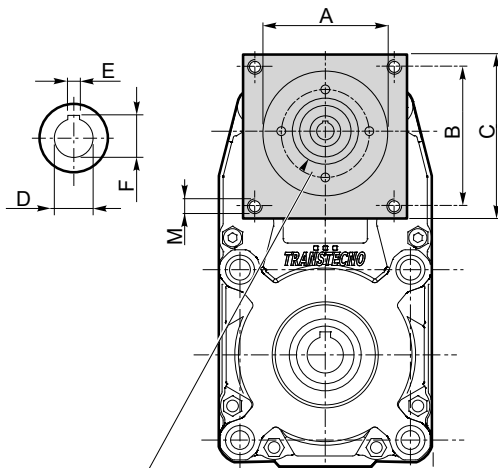

Connessione con boccola o giunto in funzione del diametro dell'albero motore.

Connection with sleeve or coupling depending on motor shaft's diameter.

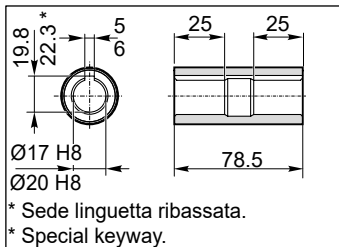

* Sede linguetta ribassata.
* Special keyway.
Albero lento cavo / Hollow output shaft

Kg
4.2

Dimensioni / Dimensions									
AS	A	B	C	M	K	D	E	F	
AS416	38.1	47.1	56.6	M5	101.8	9	3	10.4	
...

Motoriduttori brushless CC a vite senza fine
Brushless DC wormgearmotors

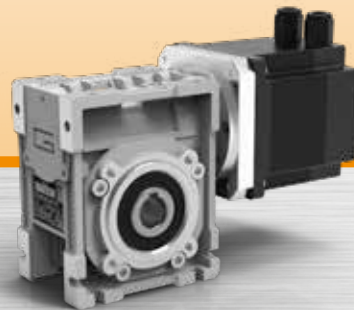

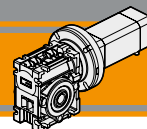

Indice	Index	Pag. Page
Caratteristiche tecniche	<i>Technical features</i>	CD2
Designazione	<i>Classification</i>	CD2
Simbologia	<i>Symbols</i>	CD3
Lubrificazione e temperatura	<i>Lubrication and temperature</i>	CD3
Carichi radiali	<i>Radial loads</i>	CD3
Dati di dentatura	<i>Toothing data</i>	CD4
Rendimento	<i>Efficiency</i>	CD4
Rerersibilità e irreversibilità	<i>Reversibility and irreversibility</i>	CD4
CM026 con motore brushless BLS 022.240	<i>CM026 with brushless motor BLS 022.240</i>	CD5
CM030 con motore brushless BLS 043.240	<i>CM030 with brushless motor BLS 043.240</i>	CD6
CM030 con motore brushless BL 070.480	<i>CM030 with brushless motor BL 070.480</i>	CD7
CM040 con motore brushless BLS 043.240	<i>CM040 with brushless motor BLS 043.240</i>	CD8
CM040 con motore brushless BL 070.480	<i>CM040 with brushless motor BL 070.480</i>	CD9
CM040 con motore brushless BL 140.480	<i>CM040 with brushless motor BL 140.480</i>	CD9
CM040 con motore brushless BL 210.480	<i>CM040 with brushless motor BL 210.480</i>	CD9
Dati tecnici	<i>Technical data</i>	CD10
Dimensioni CM con flange motore AS	<i>CM dimensions with motor flanges AS</i>	CD11
Dimensioni flange uscita	<i>Output flange dimensions</i>	CD13
Opzioni	<i>Options</i>	CD14
Accessori	<i>Accessories</i>	CD14

Questa sezione annulla e sostituisce ogni precedente edizione o revisione. Qualora questa sezione non Vi sia giunta in distribuzione controllata, l'aggiornamento dei dati ivi contenuto non è assicurato. **In tal caso la versione più aggiornata è disponibile sul nostro sito internet www.transtecno.com**

This section replaces any previous edition and revision. If you obtained this catalogue other than through controlled distribution channels, the most up to date content is not guaranteed. In this case the latest version is available on our web site www.transtecno.com

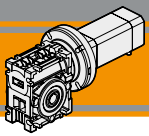

Caratteristiche tecniche

Technical features

Le caratteristiche principali dei motoriduttori brushless CC a vite senza fine della serie BLCM sono:

The main features of BLCM brushless DC wormgearmotors range are:

- Alimentazione in bassa tensione 24/36/48 Vcc
- Motore Brushless CC con grado di protezione IP55
- Coppie motore disponibili da 0.22 a 2.1 Nm
- Carcasse dei riduttori in pressofusione di alluminio
- Lubrificazione permanente con olio sintetico
- Disponibili anche nella versione con solo riduttore, sia con flangia di entrata standard che con flangia e manicotto dedicati
- Low voltage power supply 24/36/48 Vdc
- Brushless DC motor in IP55 protection Standard
- Motor torque ratings available from 0.22 up to 2.1 Nm
- Die-cast aluminium housings
- Permanent synthetic oil long life lubrication
- Gearbox only version also available, with either standard input flange or customized flange and coupling

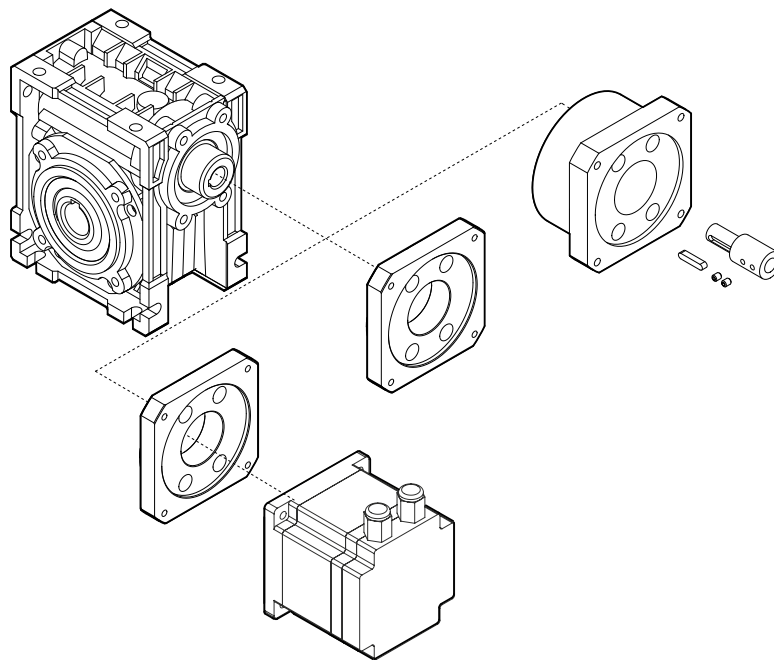

Designazione

Classification

RIDUTTORE / GEARBOX				MOTORE / MOTOR	
CM	030	20	U	BL070.480	48V
Tipo Type	Grandezza Size	Rapporto in Ratio in	Versione Version	Tipo Type	Tensione Voltage
CM	026 026 (11) 026 (14) 030 040	Vedere tabelle See tables	U F FL FB	BLS022.240 BLS043.240 BL070.480 BL140.480 BL210.480	24V-36V 24V-36V 48V 48V 48V

Versione Riduttore
Gearbox Version

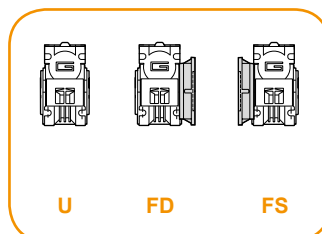

U FD FS

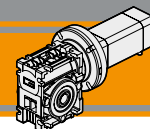

Simbologia

Symbols

Ns	n° stadi / No. stages	n _{1MAX}	[Rpm]	Velocità max entrata / Max input speed
ir	rapporto reale / real ratio	V	[V]	Tensione / Voltage
M ₂	[Nm] coppia in uscita / output torque	n ₂	[Rpm]	Velocità in uscita / Output Speed
A ₂	[N] Carico assiale ammissibile in uscita / Permitted output axial load	IP		Grado di protezione / Enclosure protection
R ₂	[N] Carico radiale ammissibile in uscita / Permitted output radial load	Kg		Peso / Weight
Pn ₁	[kW] Potenza nominale in entrata / Nominal input power	sf		Fattore di servizio / Service Factor
Mn ₂	[Nm] Coppia nominale in uscita in funzione di Pn1 / Nominal output torque referred to Pn1	Rd	%	Rendimento dinamico / Dynamic efficiency
		Rs	%	Rendimento statico / Static efficiency
		Z		Numero di principi della vite / Worm starts
		β		Angolo d'elica / Helix angle

Lubrificazione e temperatura

Lubrication and temperature

Tutti i motoriduttori BLCM sono forniti completi di lubrificante sintetico viscosità 320, pertanto possono essere installati in qualunque posizione di montaggio e non necessitano di manutenzione.

Permanent synthetic oil long-life lubrication (viscosity grade 320) makes it possible to use the BLCM worm gearmotors in all mounting positions; for this reason they can be installed in any assembly position and do not require maintenance.

Temperatura ambiente 0 ÷ 40 °C (in assenza di congelamento ed in assenza di condensa).

Ambient temperature 0 ÷ 40 °C (in the absence of freezing and condensation).

Per temperature diverse, contattare nostro UT.

For temperature outside this range please contact our technical dept.

Carichi radiali

Radial loads

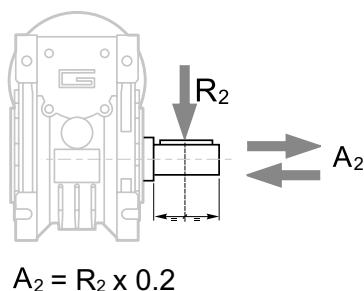

n ₂ [min ⁻¹]	R ₂ [N]		
	CM026	CM030	CM040
187	400	674	1264
140	490	743	1392
93	480	851	1596
70	610	936	1754
56	610	1008	1890
47	610	1069	2004
35	610	1179	2210
28	610	1270	2381
23	610	1356	2542
18	610	1471	2759
14	610	1600	3000

Quando il carico radiale risultante non è applicato sulla mezzeria dell'albero occorre calcolare quello effettivo con la seguente formula:

When the resulting radial load is not applied on the centre line of the shaft it is necessary to calculate the effective load with the following formula:

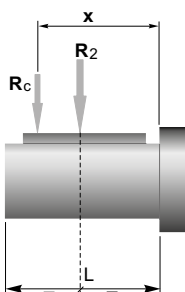

	CM		
	026	030	040
a	56	65	84
b	43	50	64
R _{2MAX}	610	1600	3000

$$R_c = \frac{R_2 \cdot a}{(b+x)} \leq R_{2MAX}$$

$$R \leq R_c$$

a. b = valori riportati nella tabella
a. b = values given in the table

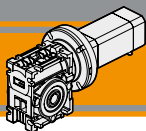
**Dati di dentatura****Toothing data**

	Dati della coppia vite-corona Worm wheel data	Rapporto / Ratio											
		5	7.5	10	15	20	25	30	40	50	60	80	100
CM026	Z	6	4	3	2	2		1	1	1	1		
	β	34° 35'	24° 41'	19° 1'	12° 57'	10° 30'		6° 33'	5° 17'	4° 26'	3° 49'		
CM030	Z	6	4	3	2	2	2	1	1	1	1	1	1
	β	27° 4'	24° 28'	18° 50'	12° 49'	10° 23'	8° 43'	6° 29'	5° 14'	4° 23'	3° 46'	2° 57'	2° 25'
CM040	Z	6	4	3	2	2	2	1	1	1	1	1	1
	β	34° 19'	24° 28'	18° 50'	12° 49'	10° 23'	8° 43'	6° 29'	5° 14'	4° 23'	3° 46'	2° 57'	2° 25'

Rendimento**Efficiency**

	n_1 [min ⁻¹]	Rendimento Efficiency	Rapporto / Ratio											
			5	7.5	10	15	20	25	30	40	50	60	80	100
CM026	2800	Rd	89	87	85	83	80		73	68	64	60		
		Rs	72	71	68	61	56	46	41	36	34			
CM030	2800	Rd	89	88	86	84	81	78	74	70	65	62	57	52
		Rs	72	67	63	55	50	43	39	35	31	27	23	21
CM040	2800	Rd	90	89	87	84	83	80	77	73	69	66	60	56
		Rs	74	71	67	60	55	51	45	40	36	32	28	24

Reversibilità e irreversibilità**Reversibility and irreversibility**

La tabella sottostante riporta a titolo puramente indicativo i vari gradi di reversibilità/irreversibilità nei riduttori a vite senza fine in funzione del rendimento dinamico Rd e statico Rs.

The table below is provided for reference purposes only. It contains the various degrees of reversibility/irreversibility of wormgearboxes in relation to dynamic Rd and static Rs efficiency.

Rd	Reversibilità e irreversibilità dinamica	Dynamic reversibility and irreversibility
> 0.60	Reversibilità dinamica	Dynamic reversibility
0.50 - 0.60	Reversibilità dinamica incerta	Uncertain dynamic reversibility
0.40 - 0.50	Buona irreversibilità dinamica	Good dynamic irreversibility
<0.40	Irreversibilità dinamica	Dynamic irreversibility
Rs	Reversibilità e irreversibilità statica	Static reversibility and irreversibility
> 0.55	Reversibilità statica	Static reversibility
0.50 - 0.55	Reversibilità statica incerta	Uncertain static reversibility
<0.50	Irreversibilità statica	Static irreversibility

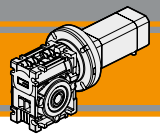

CM026 con motore brushless

CM026 with brushless motor

CM026	BLS022.240											
	24V						36V					
	ir	n ₂ MIN		n ₂ MAX		n ₁ MAX [rpm]	n ₂ MIN		n ₂ MAX		n ₁ MAX [rpm]	
M ₂		sf	M ₂	sf	M ₂		sf	M ₂	sf			
5	60	0.9	27	600	1.0	10	80	0.9	21	800	1.0	8.0
7.5	40	1.3	19	400	1.5	7.9	53	1.3	16	533	1.5	6.0
10	30	1.7	16	300	1.9	5.8	40	1.7	12	400	1.9	4.7
15	20	2.2	12	200	2.7	4.1	27	2.3	9.1	267	2.8	3.2
20	15	2.8	9.3	150	3.5	3.1	20	2.9	6.9	200	3.6	2.5
30	10	3.6	7.5	100	4.8	2.5	13	3.8	5.8	133	5.0	2.0
40	7.5	4.4	4.8	75	6.0	1.8	10	4.6	4.1	100	6.2	1.5
50	6	4.8	4.2	60	7.0	1.4	8.0	5.2	3.5	80	7.3	1.1
60	5	5.4	3.3	50	7.8	1.1	6.7	5.8	2.9	67	8.2	0.9

Attenzione: superamento della coppia nominale supportata dal riduttore per servizio S1. Contattare il ns. servizio tecnico
Attention: rated torque withstood by gear reducer for service in S1 is exceeded. Please, contact our technical office.

Tipo Type	Numero di poli Number of poles	Numero di fasi Number of phase	Tensione Rated voltage [V]	Numero di giri Rated speed [rpm]	Coppia nominale Rated torque [Nm]	Potenza nominale Rated power [W]
BLS022.240	4	3	36	4000	0.22	92
			24	3000		70
Tipo Type	Coppia massima Peak torque [Nm]	Corrente nominale Rated current [A]	Resistenza Resistance [ohm]	Induttanza Inductance [mH]	Corrente massima Peak current [A]	Peso Weight [kg]
BLS022.240	0.44	3.7	0.64	3.1	7.4	0.72

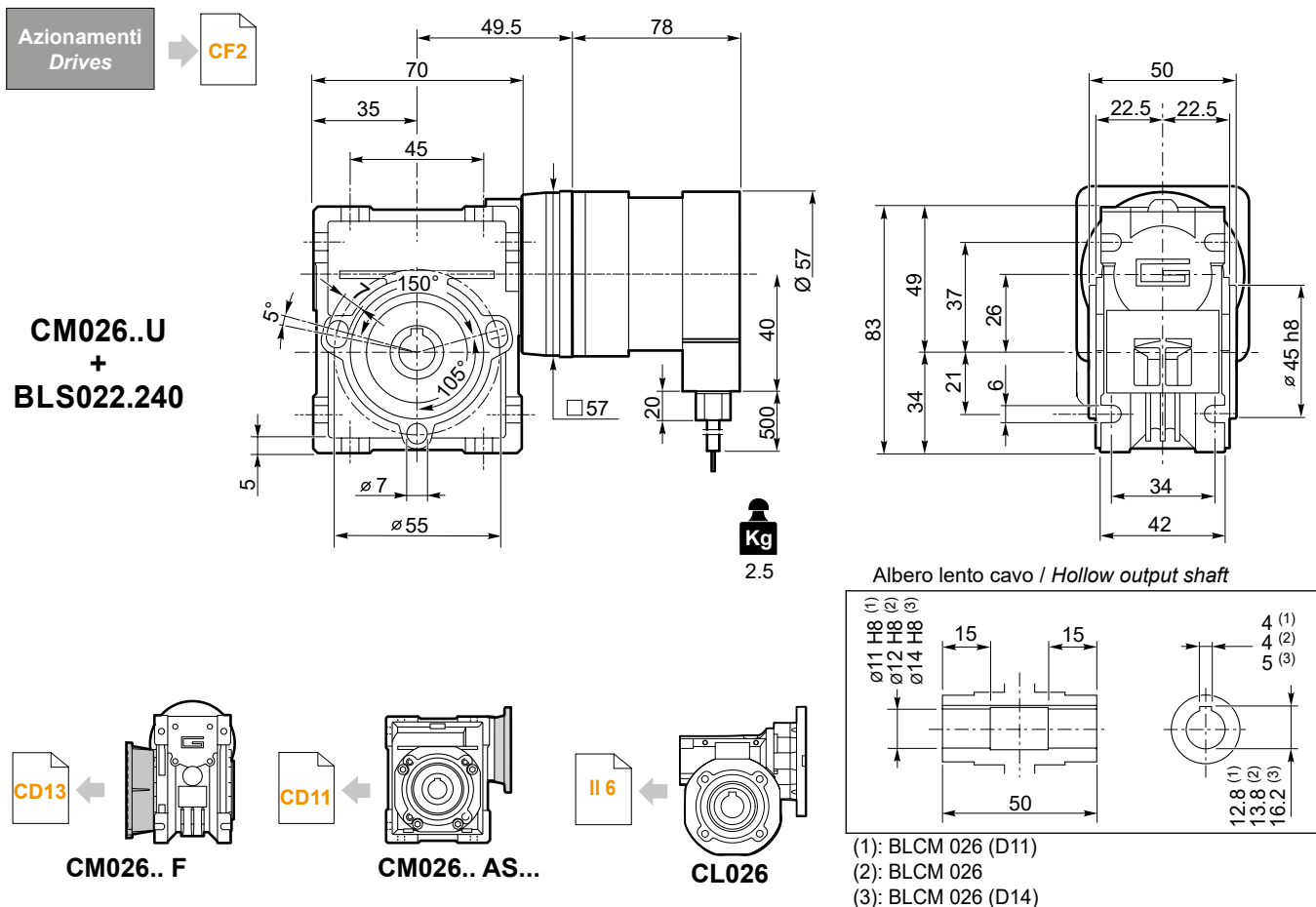

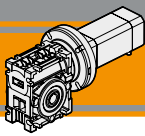

CM030 con motore brushless

CM030 with brushless motor

CM030	BLS043.240											
	24V						36V					
	ir	n ₂ MIN		n ₂ MAX		n ₁ MAX [rpm]	n ₂ MIN		n ₂ MAX		n ₁ MAX [rpm]	
M ₂		sf	M ₂	sf	M ₂		sf	M ₂	sf			
5	60	1.7	20	600	1.9	6.8	80	1.7	20	800	1.9	6.8
7.5	40	2.5	14	400	2.8	5.3	53	2.5	14	533	2.8	5.3
10	30	3.2	12	300	3.7	4.3	40	3.2	12	400	3.7	4.3
15	20	4.4	8.6	200	5.4	3.0	26	4.4	8.6	267	5.4	3.0
20	15	5.5	5.8	150	7.0	2.0	20	5.5	5.8	200	7.0	2.0
25	12	6.5	4.8	120	8.4	1.8	16	6.5	4.8	160	8.4	1.8
30	10	7.1	5.5	100	9.5	1.9	13	7.1	5.5	133	9.5	1.9
40	7.5	8.4	3.9	75	12	1.3	10	8.4	3.9	100	12	1.3
50	6.0	9.7	3.0	60	14	1.1	8	9.7	3.0	80	14	1.1
60	5.0	11	2.5	50	16	0.9	6.6	11	2.5	67	16	0.9
80	3.7	12	1.8	38	17	0.7	5	12	1.8	50	17	0.7
100	3.0	14	1.4	30	16	0.7	4	14	1.4	40	16	0.7

Attenzione: superamento della coppia nominale supportata dal riduttore per servizio S1. Contattare il ns. servizio tecnico
Attention: rated torque withstood by gear reducer for service in S1 is exceeded. Please, contact our technical office.

Tipo Type	Numero di poli Number of poles	Numero di fasi Number of phase	Tensione Rated voltage [V]	Numero di giri Rated speed [rpm]	Coppia nominale Rated torque [Nm]	Potenza nominale Rated power [W]
BLS043.240	4	3	36	4000	0.43	180
	4	3	24	3000	0.43	130
Tipo Type	Coppia massima Peak torque [Nm]	Corrente nominale Rated current [A]	Resistenza Resistance [ohm]	Induttanza Inductance [mH]	Corrente massima Peak current [A]	Peso Weight [kg]
BLS043.240	0.86	6	0.35	1.0	12.0	1.25

Azionamenti Drives



CM030..U
+
BLS043.240

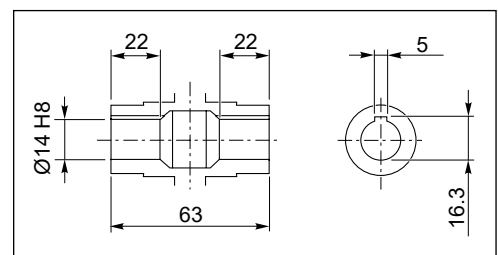
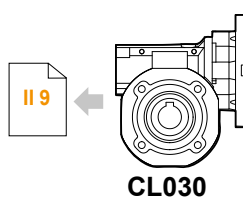
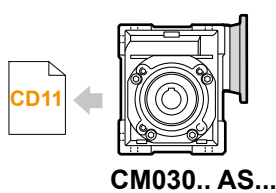
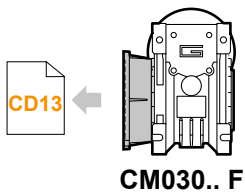
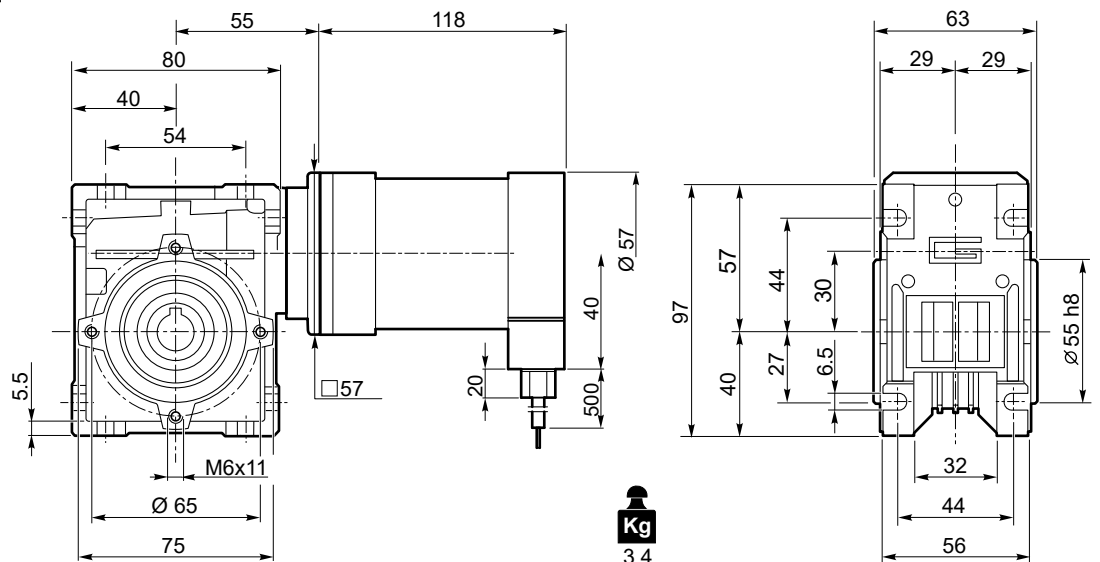

Albero lento cavo / Hollow output shaft

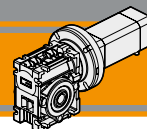

CM030 con motore brushless

CM030 with brushless motor

CM030	BL070.480						
	48V						
ir	n ₂ MIN			n ₂ MAX			n ₁ MAX [rpm]
		M ₂	sf		M ₂	sf	
5	60	2.8	11	600	3.1	4.2	3000
7.5	40	4.1	8.0	400	4.6	3.2	
10	30	5.3	6.4	300	6.0	2.7	
15	20	7.2	4.9	200	8.8	1.8	
20	15	9.1	3.2	150	11	1.2	
25	12	11	2.5	120	14	1.1	
30	10	12	2.9	100	16	1.2	
40	7.5	14	2.1	75	20	0.8	
50	6.0	16	1.6	60	23	0.7	

Attenzione: superamento della coppia nominale supportata dal riduttore per servizio S1. Contattare il ns. servizio tecnico
Attention: rated torque withstood by gear reducer for service in S1 is exceeded. Please, contact our technical office.

Tipo Type	Numero di poli Number of poles	Numero di fasi Number of phase	Tensione Rated voltage [V]	Numero di giri Rated speed [rpm]	Coppia nominale Rated torque [Nm]	Potenza nominale Rated power [W]
BL070.480	8	3	48	3000	0.7	220
Tipo Type	Coppia massima Peak torque [Nm]	Corrente nominale Rated current [A]	Resistenza Resistance [ohm]	Induttanza Inductance [mH]	Corrente massima Peak current [A]	Peso Weight [kg]
BL070.480	1.4	6.5	0.34	1.0	13	2.1

Azionamenti Drives



CM030..U
+
BL070.480

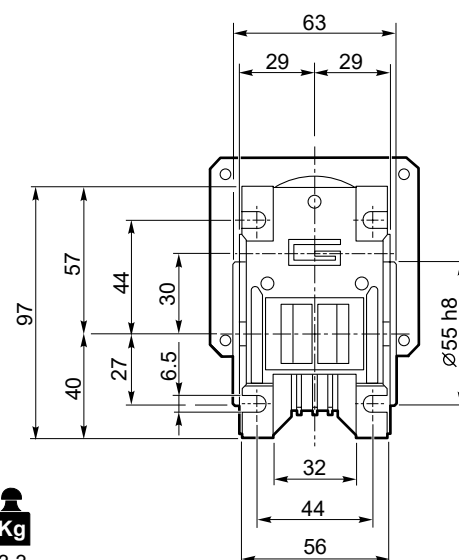
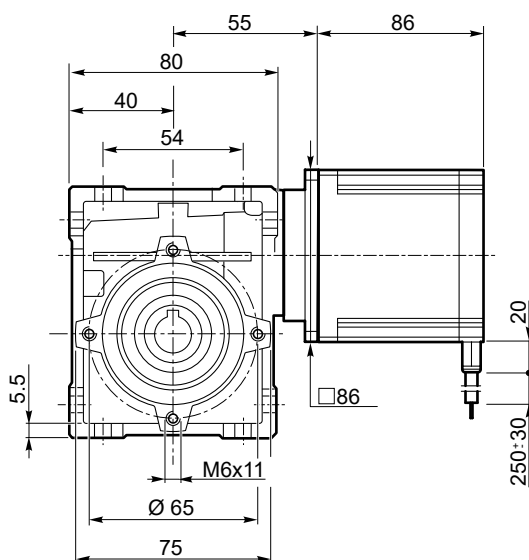

Kg
3.3

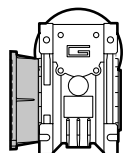

CM030.. F

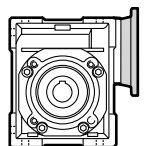

CM030.. AS...

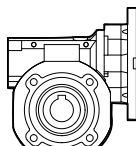

CL030

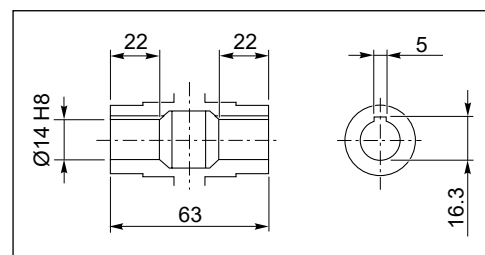

Albero lento cavo / Hollow output shaft

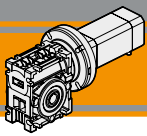

CM040 con motore brushless

CM040 with brushless motor

CM040	BLS043.240											
	24V						36V					
	n ₂ MIN		sf	n ₂ MAX		n ₁ MAX [rpm]	n ₂ MIN		sf	n ₂ MAX		n ₁ MAX [rpm]
M ₂		M ₂			M ₂			M ₂				
5	60	1.8	35	600	2.0	14	80	1.8	35	800	2.0	14
7.5	40	2.6	26	400	2.9	11	53	2.6	26	533	2.9	11
10	30	3.4	20	300	3.7	8.9	40	3.4	20	400	3.7	8.9
15	20	4.6	15	200	5.4	6.5	26	4.6	15	267	5.4	6.5
20	15	5.8	10	150	7.2	4.3	20	5.8	10	200	7.2	4.3
25	12	6.9	7.8	120	8.6	3.2	16	6.9	7.8	160	8.6	3.2
30	10	7.9	9.4	100	10	3.8	13	7.9	9.4	133	10	3.8
40	7.5	9.6	6.8	75	13	2.6	10	9.6	6.8	100	13	2.6
50	6.0	12	5.5	60	15	2.1	8	12	5.5	80	15	2.1
60	5.0	12	4.7	50	17	1.7	6.6	12	4.7	67	17	1.7
80	3.7	14	3.6	38	21	1.3	5	14	3.6	50	21	1.3
100	3.0	16	2.8	30	24	1.0	4	16	2.8	40	24	1.0

Tipo Type	Numero di poli Number of poles	Numero di fasi Number of phase	Tensione Rated voltage [V]	Numero di giri Rated speed [rpm]	Coppia nominale Rated torque [Nm]	Potenza nominale Rated power [W]
BLS043.240	4	3	36	4000	0.43	180
	4	3	24	3000	0.43	130
Tipo Type	Coppia massima Peak torque [Nm]	Corrente nominale Rated current [A]	Resistenza Resistance [ohm]	Induttanza Inductance [mH]	Corrente massima Peak current [A]	Peso Weight [kg]
BLS043.240	0.86	6	0.35	1.0	12.0	1.25

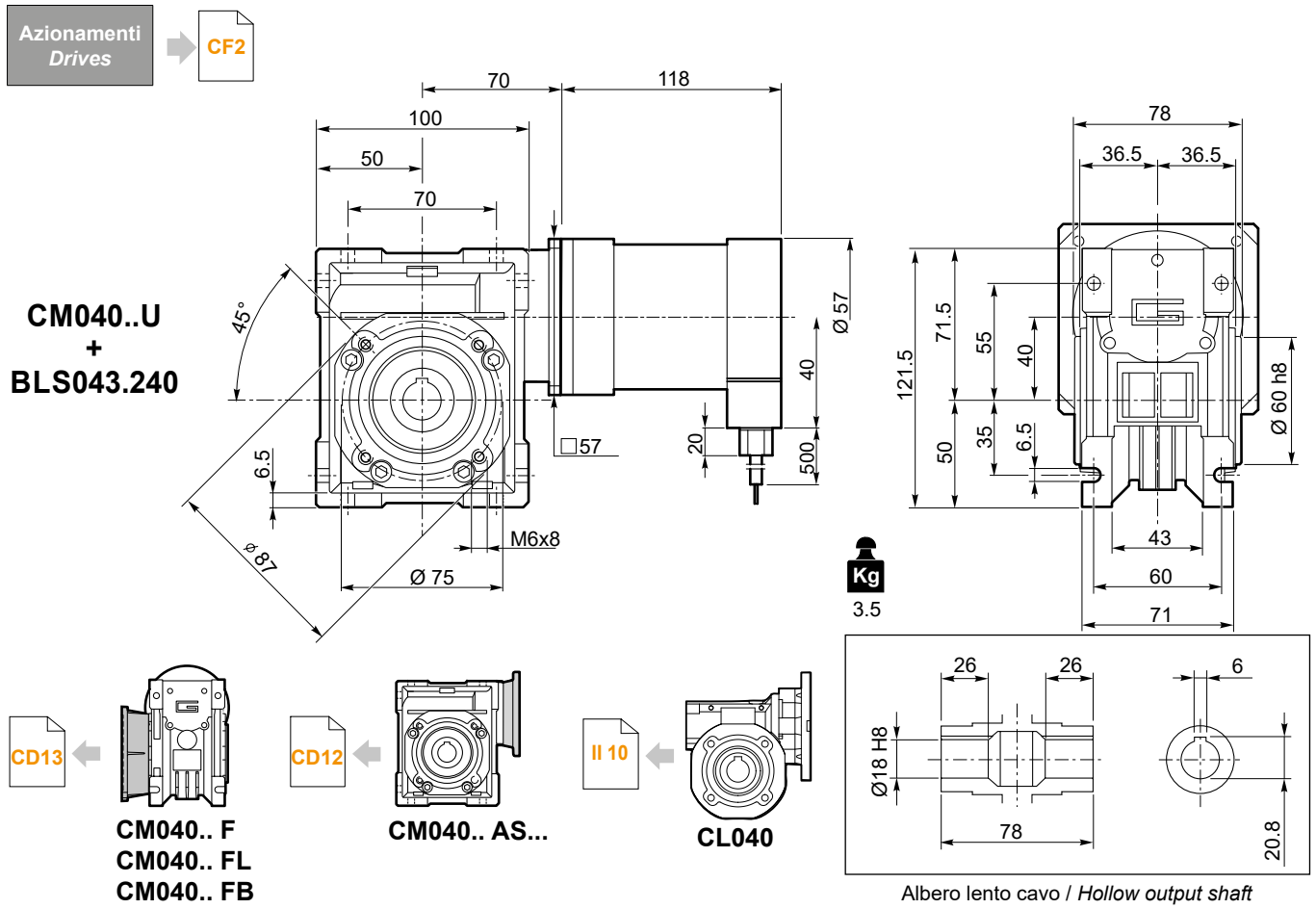

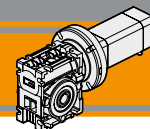

CM040 con motore brushless

CM040 with brushless motor

CM040	BL070.480							BL140.480							BL210.480						
	48V							48V							48V						
	n ₂ MIN		n ₂ MAX			n ₁ MAX [rpm]	n ₂ MIN		n ₂ MAX			n ₁ MAX [rpm]	n ₂ MIN		n ₂ MAX			n ₁ MAX [rpm]			
M ₂	sf	M ₂	sf	M ₂	sf		M ₂	sf	M ₂	sf	M ₂		sf	M ₂	sf	M ₂	sf				
5	60	2.9	25	600	3.2	9.2	3000	60	5.8	13	600	6.3	4.6	3000	60	8.6	8.5	600	9.4	3.1	3000
7.5	40	4.2	18	400	4.7	6.6		40	8.4	9.0	400	9.3	3.3		40	12	6.1	400	14	2.2	
10	30	5.3	14	300	6.1	5.4		30	11	7.1	300	12	2.7		30	16	4.7	300	18	1.8	
15	20	7.4	11	200	8.8	3.9		20	15	5.1	200	18	2.0		20	22	3.6	200	27	1.3	
20	15	9.5	7.1	150	12	2.6		15	19	3.6	150	23	1.3		15	29	2.3	150	35	0.9	
25	12	11	5.4	120	14	2.0		12	22	2.8	120	28	1.0		12	34	1.8	120	42	0.7	
30	10	12	6.7	100	16	2.3		10	24	3.4	100	32	1.2		10	37	2.2	100	49	0.8	
40	7.5	15	4.5	75	20	1.6		8	29	2.4	75	41	0.8		7.5	45	1.5	75	52	0.7	
50	6.0	17	3.7	60	24	1.3		6	33	1.9	60	46	0.7		6.0	50	1.2	60	41	0.7	
60	5.0	19	3.0	50	28	1.0		5	37	1.5	50	41	0.7		5.0	57	1.0	50	36	0.7	
80	3.7	22	2.2	38	34	0.8	4	43	1.2	38	39	0.7	3.7	66	0.7	38	43	0.7			
100	3.0	24	1.8	30	33	0.7	3	47	1.0	30	34	0.7	3.0	63	0.7	30	34	0.7			

Attenzione: superamento della coppia nominale supportata dal riduttore per servizio S1. Contattare il ns. servizio tecnico
Attention: rated torque withstood by gear reducer for service in S1 is exceeded. Please, contact our technical office.

Tipo Type	Numero di poli Number of poles	Numero di fasi Number of phase	Tensione Rated voltage [V]	Numero di giri Rated speed [rpm]	Coppia nominale Rated torque [Nm]	Potenza nominale Rated power [W]
BL070.480	8	3	48	3000	0.7	220
BL140.480	8	3	48	3000	1.4	440
BL210.480	8	3	48	3000	2.1	660

Tipo Type	Coppia massima Peak torque [Nm]	Corrente nominale Rated current [A]	Resistenza Resistance [ohm]	Induttanza Inductance [mH]	Corrente massima Peak current [A]	Peso Weight [kg]
BL070.480	1.4	6.5	0.34	1.0	13	2.1
BL140.480	2.8	13.0	0.16	0.5	26	3.15
BL210.480	4.2	18.7	0.115	0.31	37	4.2

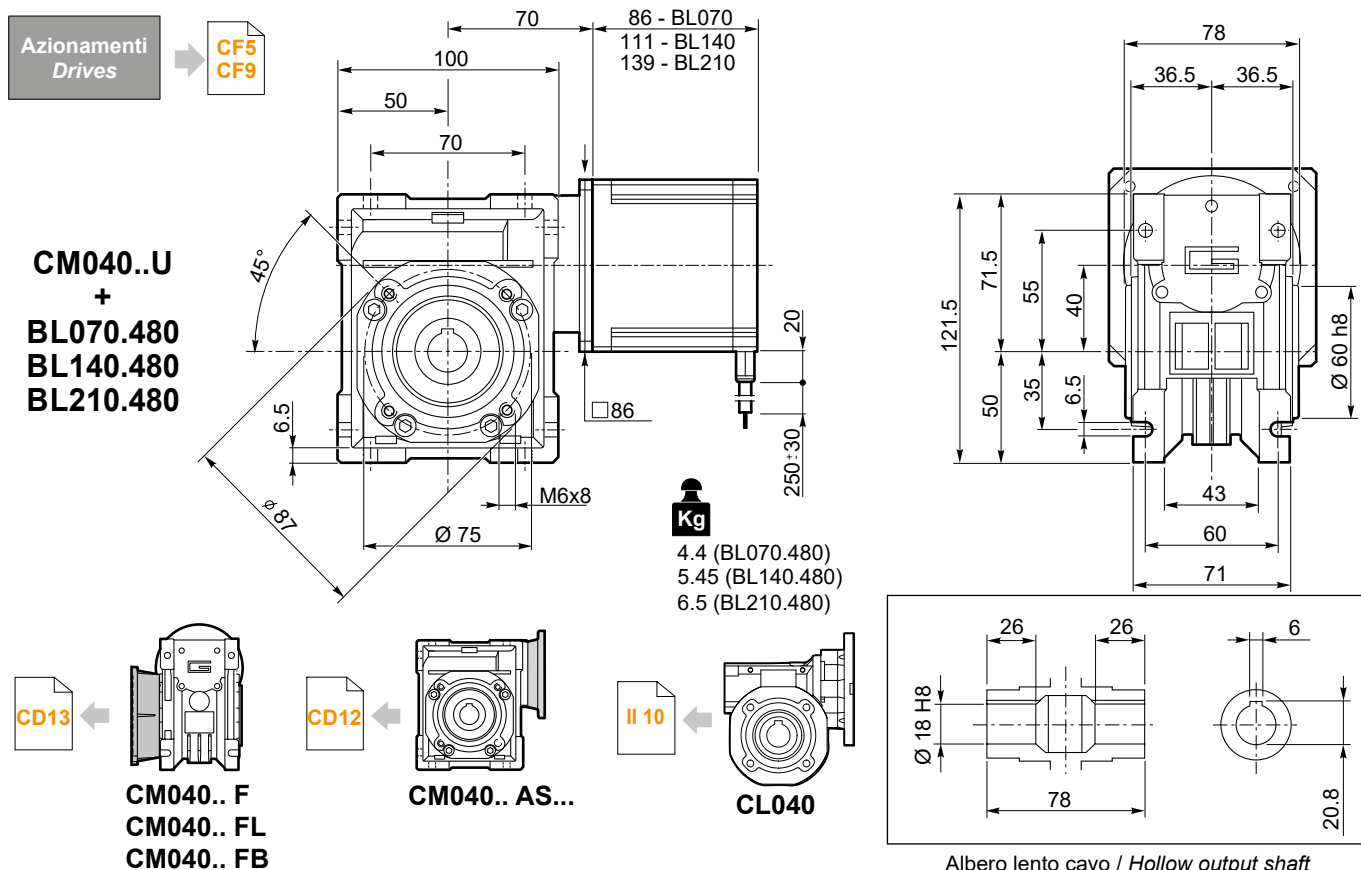

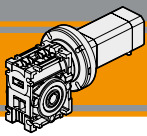
**Dati tecnici****Technical data**

	n_2 [min ⁻¹]	Mn_2 [Nm]	Pn_1 [kW]	i
---	-------------------------------	----------------	----------------	-----

	n_2 [min ⁻¹]	Mn_2 [Nm]	Pn_1 [kW]	i
---	-------------------------------	----------------	----------------	-----

CM026

$n_1 = 1400 \text{ rpm}$	n_2	Mn_2	Pn_1	i
	280	13	0.44	5
	187	14	0.33	7,5
	140	14	0.25	10
	93	14	0.18	15
	70	14	0.14	20
	47	15	0.11	30
	35	14	0.08	40
	28	13	0.07	50
	23	12	0.06	60

CM026

$n_1 = 3000 \text{ rpm}$	n_2	Mn_2	Pn_1	i
	600	10	0.71	5
	400	11	0.53	7,5
	300	11	0.41	10
	200	11	0.28	15
	150	11	0.22	20
	100	12	0.17	30
	75	11	0.13	40
	60	10	0.10	50
	50	9	0.08	60

CM030

$n_1 = 1400 \text{ rpm}$	n_2	Mn_2	Pn_1	i
	280	18	0.61	5
	187	20	0.46	7,5
	140	21	0.37	10
	93	21	0.26	15
	70	19	0.19	20
	56	20	0.16	25
	47	22	0.16	30
	35	20	0.12	40
	28	19	0.10	50
	23	17	0.08	60
	18	15	0.06	80
	14	14	0.05	100

CM030

$n_1 = 3000 \text{ rpm}$	n_2	Mn_2	Pn_1	i
	600	13	0.92	5
	400	15	0.71	7,5
	300	16	0.58	10
	200	16	0.40	15
	150	14	0.27	20
	120	15	0.24	25
	100	18	0.25	30
	75	16	0.18	40
	60	15	0.14	50
	50	14	0.12	60
	37.5	12	0.08	80
	30	11	0.07	100

CM040

$n_1 = 1400 \text{ rpm}$	n_2	Mn_2	Pn_1	i
	280	41	1.37	5
	187	44	1.00	7,5
	140	45	0.79	10
	93	45	0.54	15
	70	40	0.38	20
	56	38	0.30	25
	47	48	0.34	30
	35	42	0.24	40
	28	39	0.19	50
	23	36	0.15	60
	18	33	0.12	80
	14	31	0.10	100

CM040

$n_1 = 3000 \text{ rpm}$	n_2	Mn_2	Pn_1	i
	600	29	2.02	5
	400	31	1.46	7,5
	300	33	1.19	10
	200	35	0.87	15
	150	31	0.59	20
	120	28	0.44	25
	100	38	0.52	30
	75	34	0.37	40
	60	32	0.29	50
	50	29	0.23	60
	37.5	27	0.18	80
	30	24	0.13	100

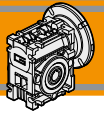

Dimensioni CM con flange motore AS

CM dimensions with motor flanges AS

CM026 - U - AS...

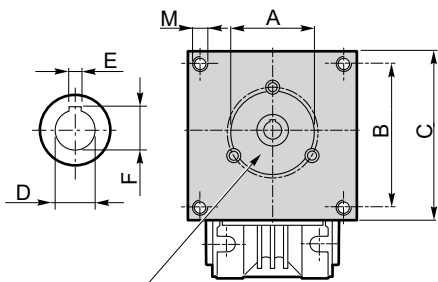

Connessione con boccola o giunto in funzione del diametro dell'albero motore.

Connection with sleeve or coupling depending on motorshaft's diameter.

Albero lento cavo / Hollow output shaft

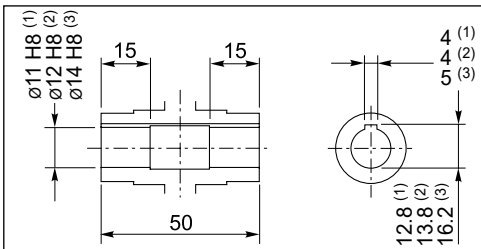

- (1): BLCM 026 (D11)
- (2): BLCM 026
- (3): BLCM 026 (D14)

Lo spessore della flangia è variabile in funzione delle diverse lunghezze dell'albero motore.

Flange's thickness may vary depending on motorshaft's lenght.

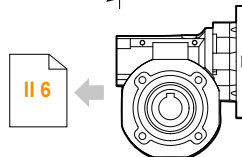
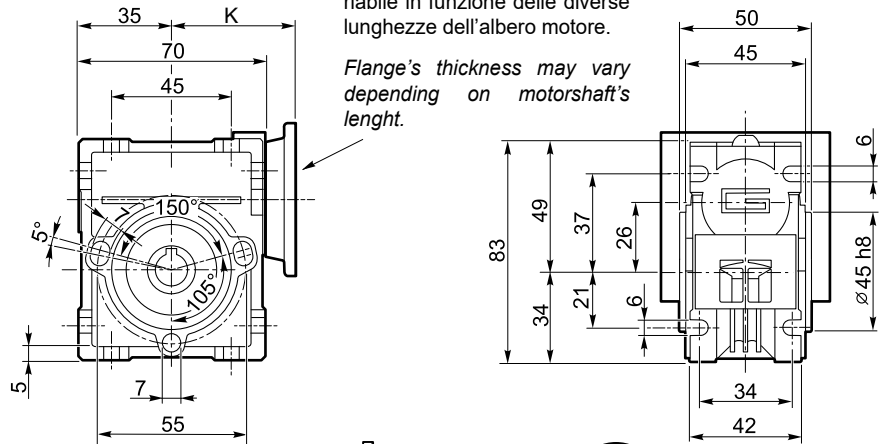

CL026

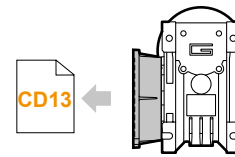

CM026.. F

Kg
0.8

Dimensioni / Dimensions						Rapporti / Ratio		
AS	A	B	C	M	K	5...100		
						D	E	F
AS417	38.1	47.1	56	M4	49.5	9	3	10.4
...

CM030 - U - AS...

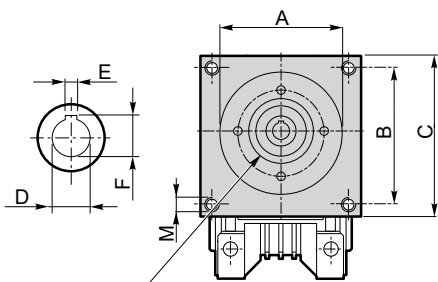

Connessione con boccola o giunto in funzione del diametro dell'albero motore.

Connection with sleeve or coupling depending on motorshaft's diameter.

Lo spessore della flangia è variabile in funzione delle diverse lunghezze dell'albero motore.

Flange's thickness may vary depending on motorshaft's lenght.

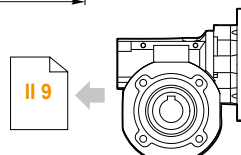
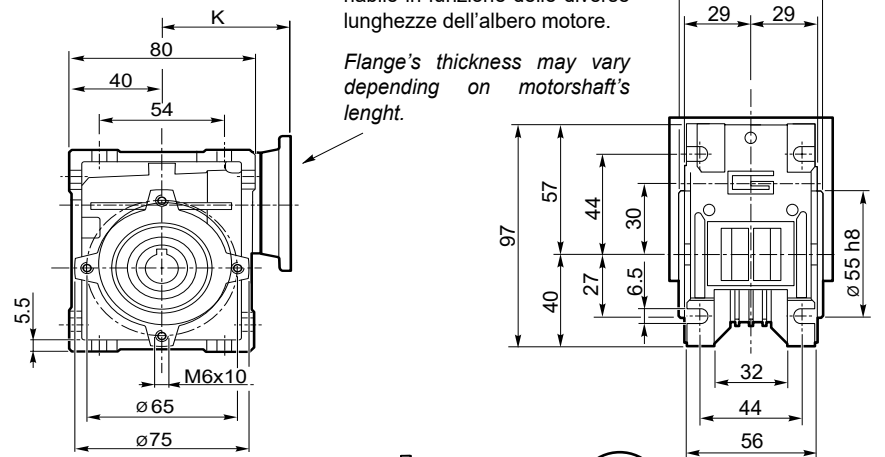

CL030

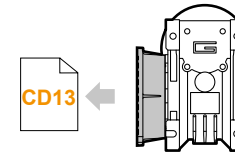

CM030.. F

Kg
1.2

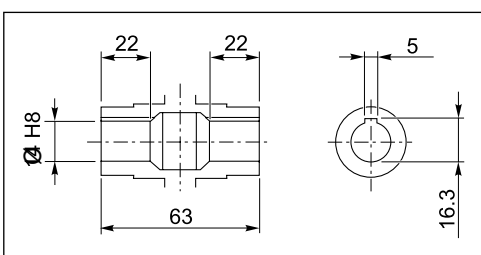

Albero lento cavo / Hollow output shaft

Dimensioni / Dimensions						Rapporti / Ratio					
AS	A	B	C	M	K	5...50			60...100		
						D	E	F	D	E	F
AS393	38.1	47.1	57	M5	55	11	4	12.8	9	3	10.4
AS391	73	69.6	86	M5	55	11	4	12.8	9	3	10.4
...

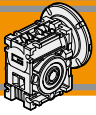

CM

Riduttori a vite senza fine
Wormgearboxes



Dimensioni CM con flange motore AS

CM dimensions with motor flanges AS

CM040 - U - AS...

Lo spessore della flangia è variabile in funzione delle diverse lunghezze dell'albero motore.

Flange's thickness may vary depending on motorshaft's length.

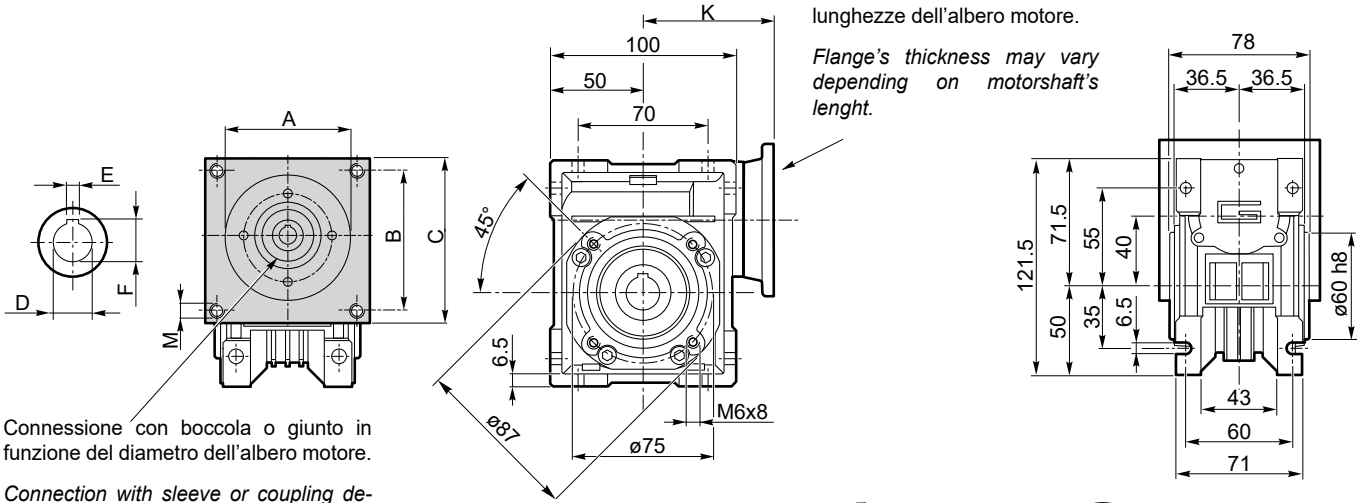

Connessione con boccia o giunto in funzione del diametro dell'albero motore.

Connection with sleeve or coupling depending on motorshaft's diameter.

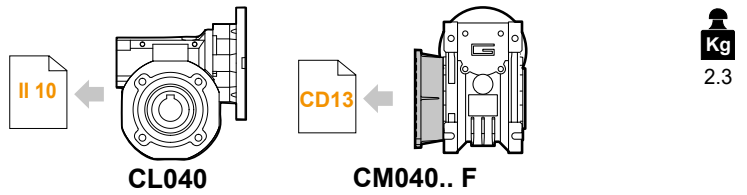

CL040

CM040.. F

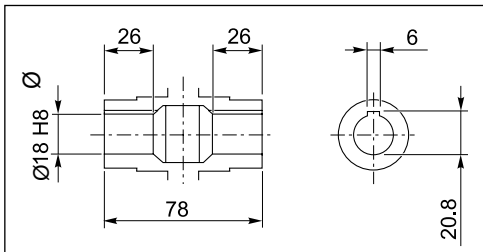

Albero lento cavo / Hollow output shaft

Dimensioni / Dimensions											
AS	A	B	C	M	K	Rapporti / Ratio					
						5...40			50...100		
						D	E	F	D	E	F
AS392	38.1	47.1	64	M5	70	14	5	16.3	11	4	12.8
AS384	73	69.6	86	M5	70	14	5	16.3	11	4	12.8
...

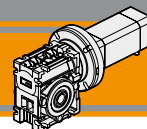

Dimensioni flange uscita

Output flange dimensions

CM.../... F... Flange uscita / Output flanges

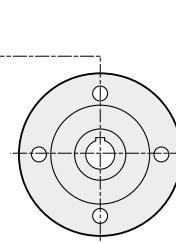
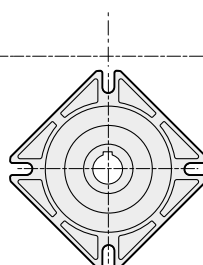
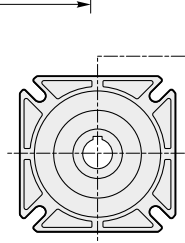
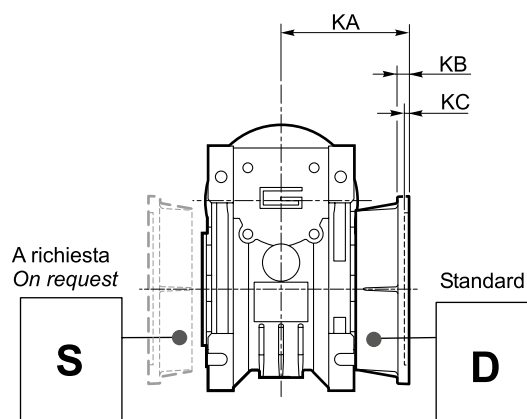
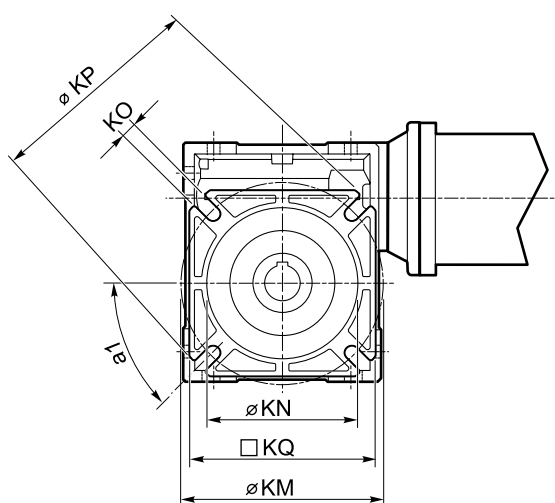

..CM026 ../.. F
..CM026 ../.. F28
..CM026 ../.. F30
..CM026 ../.. F30S
..CM030 ../.. F..
..CM040 ../.. F..

..CM026 ../.. F30C
..CM026 ../.. F30SC

..CM026 ../.. F100

	CM..F								CM..F28								CM..F30								CM..F30S ⁽¹⁾								
	a1	KA	KB	KC	KM	KN _{H8}	KO	KP	KQ	KA	KB	KC	KM	KN _{H8}	KO	KP	KQ	KA	KB	KC	KM	KN _{H8}	KO	KP	KQ	KA	KB	KC	KM	KN _{H8}	KO	KP	KQ
026 (D11)	45°	45	6	4.5	55-69	40	6.5	75	70	44	6.5	5	56-64	40	6.5	70	60	48	6.5	5	68	50	6.5	80	70	50	8.5	7	68	50	6.5	80	70
026 (D14)							(n.4)																										

(1): F30S eseguita con F30 e distanziale di spessore 2 mm / F30S made with F30 and spacer with 2mm thickness

	CM..F30C								CM..F30SC ⁽²⁾								CM..F100								
	a1	KA	KB	KC	KM	KN _{H8}	KO	KP	KQ	KA	KB	KC	KM	KN _{H8}	KO	KP	KQ	KA	KB	KC *	KM	KN _{H7}	KO	KP	KQ
026 (D11)	-	48	6.5	7	68	50	6.5	80	70	50	8.5	7	68	50	6.5	80	70	51.5	8	2 *	86	45	6.5	100	-
026 (D14)																									

(2): F30SC eseguita con F30C e distanziale di spessore 2 mm / F30SC made with F30C and spacer with 2mm thickness

*: Centraggio maschio / Male centering diameter

CM	CM..F								CM..FB								CM..FL								
	a1	KA	KB	KC	KM	KN _{H8}	KO	KP	KQ	KA	KB	KC	KM	KN _{H8}	KO	KP	KQ	KA	KB	KC	KM	KN _{H8}	KO	KP	KQ
030	45°	54.5	6	4	68	50	6.5(n.4)	80	70	—	—	—	—	—	—	—	—	—	—	—	—	—	—	—	—
040	45°	67	7.5	4	80-95	60	9(n.4)	110	95	80	8.5	5	115-125	95	9.5(n.4)	140	112	97	7.5	4.5	80-95	60	9 (n.4)	110	95

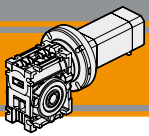

Opzioni

Options

VS - Vite sporgente / Extended input shaft

SC - Safety cover

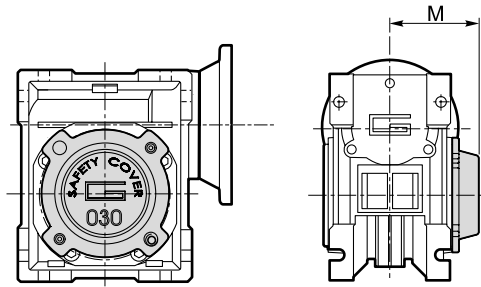
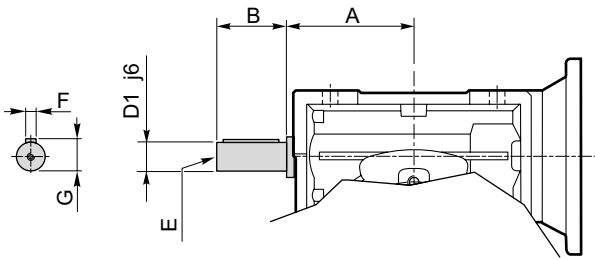

	A	B	D ₁ j6	E	F	G
CM 030	45	20	9	M4	3	10.2
CM 040	53	23	11	M5	4	12.5

	M
CM 030	47
CM 040	54.5

 Costruito su richiesta
Built on request

Accessori

Accessories

Albero lento

Output shaft

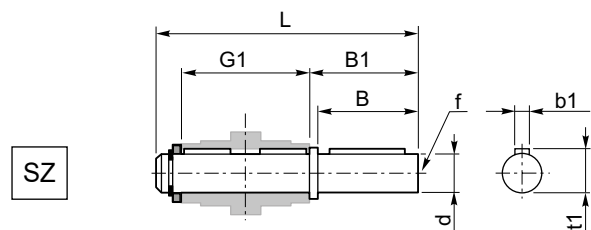
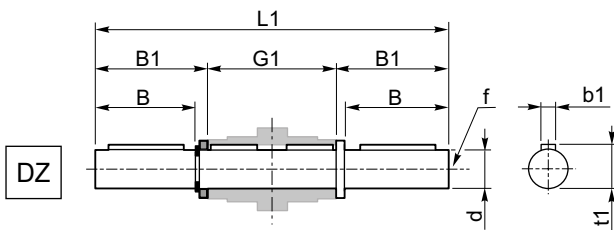

	d h7	B	B1	G1	L	L1	f	b1	t1
CM 030	14	30	32.5	63	102	128	M6	5	16
CM 040	18	40	43	78	128	164	M6	6	20.5

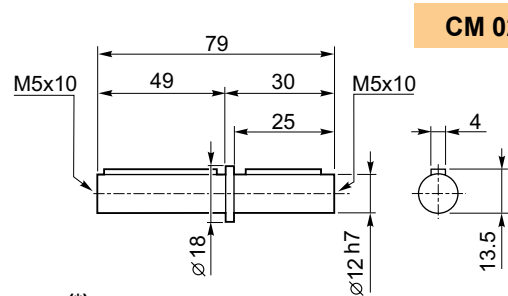

CM 026 (*)

(*)
Nota: disponibile solo per cavo uscita Ø12
Note: available for output hollow shaft Ø12 only

Braccio di reazione

Torque arm

	K1	G	KG	KH	R
CM 030	85	14	23	8	15
CM 040	100	14	31	10	18

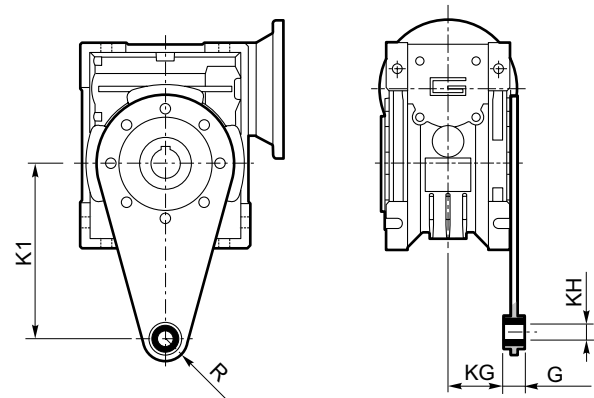

Motoriduttori brushless CC epicicloidali
Brushless DC planetary gearmotors



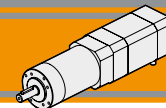

Indice	Index	Pag. Page
Caratteristiche tecniche	<i>Technical features</i>	CE2
Designazione	<i>Classification</i>	CE2
Simbologia	<i>Symbols</i>	CE2
Lubrificazione e temperatura	<i>Lubrication and temperature</i>	CE3
Carichi radiali	<i>Radial loads</i>	CE3
Rapporti	<i>Ratios</i>	CE3
P52 con motore brushless BLS 022.240	<i>P52 with brushless motor BLS 022.240</i>	CE4
P52 con motore brushless BLS 043.240	<i>P52 with brushless motor BLS 043.240</i>	CE6
P62 con motore brushless BL 070.480	<i>P62 with brushless motor BL 070.480</i>	CE8
P62 con motore brushless BL 140.480	<i>P62 with brushless motor BL 140.480</i>	CE8
Dati tecnici	<i>Technical data</i>	CE10
Dimensioni P con flange motore AS	<i>P dimensions with motor flanges AS</i>	CE11
Flange uscita	<i>Output flange</i>	CE12

Questa sezione annulla e sostituisce ogni precedente edizione o revisione. Qualora questa sezione non Vi sia giunta in distribuzione controllata, l'aggiornamento dei dati ivi contenuto non è assicurato. **In tal caso la versione più aggiornata è disponibile sul nostro sito internet www.transtecno.com**

This section replaces any previous edition and revision. If you obtained this catalogue other than through controlled distribution channels, the most up to date content is not guaranteed. In this case the latest version is available on our web site www.transtecno.com

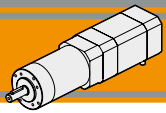

Caratteristiche tecniche

Technical features

Le caratteristiche principali dei motoriduttori brushless CC epicicloidali della serie BLP sono:

The main features of brushless DC planetary gearmotors BLP range are:

- Alimentazione in bassa tensione 24/36/48 Vcc
- Motore Brushless CC con grado di protezione IP55
- Coppie motori disponibili da 0.22 Nm a 1.4 Nm
- Lubrificazione permanente a grasso
- Completamente in metallo
- Doppio cuscinetto su albero di uscita
- Disponibili anche nella versione con solo riduttore, sia con flangia di entrata standard che con flangia e manicotto dedicati

- Low voltage power supply 24/36/48 Vdc
- Brushless DC motor in IP55 protection Standard
- Motor torque ratings available from 0.22 Nm up to 1.4 Nm
- Permanent grease long life lubrication
- Completely made out of metal
- Double ball bearing on output shaft
- Gearbox only version also available, with either standard input flange or customized flange and coupling

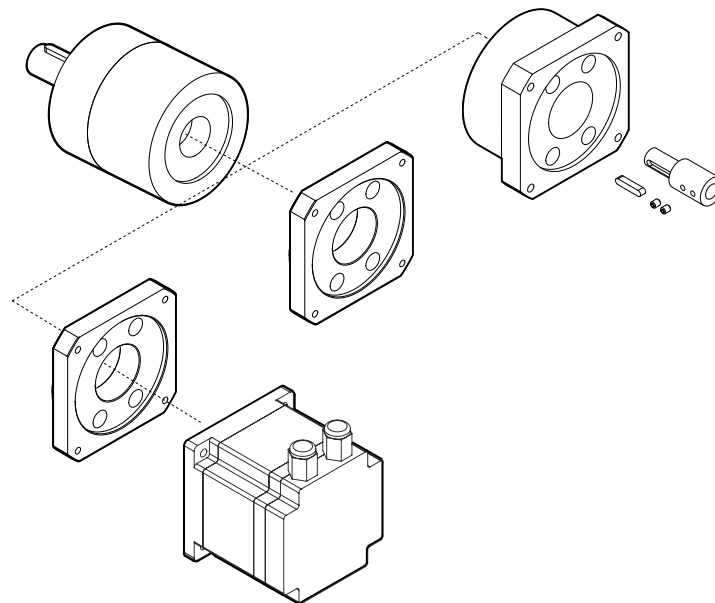

Designazione

Classification

RIDUTTORE / GEARBOX			
P	52	2	46
Tipo Type	Grandezza Size	Stadi riduttore Gearbox stages	Rapporto in Ratio in
P	52 62	1 2 3	Vedere tabelle See tables

MOTORE / MOTOR	
BL070.480	48V
Tipo Type	Tensione Voltage
BLS022.240	24V-36V
BLS043.240	24V-36V
BL070.480	48V
BL140.480	48V

Simbologia

Symbols

Ns	n° stadi / No. stages	Mn ₂	[Nm]	Coppia nominale in uscita in funzione di Pn ₁ Nominal output torque referred to Pn ₁
ir	rapporto reale / real ratio	V	[V]	Tensione / Voltage
M ₂	[Nm] coppia in uscita output torque	n _{1MAX}	[Rpm]	Velocità max entrata / Max input speed
Rd	rendimento dinamico / efficiency	n ₂	[Rpm]	Velocità in uscita / Output Speed
A ₂	[N] Carico assiale ammissibile in uscita Permitted output axial load	IP		Grado di protezione / Enclosure protection
R ₂	[N] Carico radiale ammissibile in uscita Permitted output radial load	Kg		Peso / Weight
Pn ₁	[kW] Potenza nominale in entrata Nominal input power	sf		Fattore di servizio / Service Factor

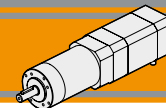

Lubrificazione e temperatura

Lubrication and temperature

I motoriduttori epicicloidali BLP sono lubrificati in modo permanente, non richiedono quindi ulteriore manutenzione. Questo gli consente di essere installati praticamente ovunque. Temperatura ambiente 0 ÷ 40 °C (in assenza di congelamento ed in assenza di condensa). Per temperature diverse, contattare nostro UT.

Planetary BLP gearmotors are life-time lubricated with grease, therefore they are maintenance free. They can be installed in any location. Ambient temperature 0 ÷ 40 °C (in the absence of freezing and condensation). For temperature outside this range please contact our technical dept.

Carichi radiali

Radial loads

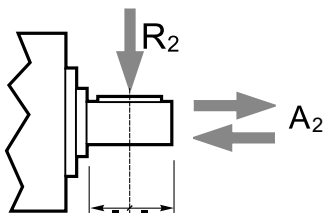

Ns	Carichi Radiali R ₂ [N] / Radial Load R ₂ [N]	
	P52	P62
1	200	240
2	320	360
3	450	520

Ns	Carichi Assiali A ₂ [N] / Axial Load A ₂ [N]	
	P52	P62
1	60	70
2	100	100
3	150	150

Rapporti

Ratios

Ns	P 52 / 62		Rd	P 52	P62
	in	ir		kg	kg
1	4	3.7	0.8	0.7	0.8
	4	4.28			
	5	5.18			
	7	6.75			
2	14	13.73	0.75	0.9	1.2
	16	15.88			
	18	18.36			
	19	19.2			
	22	22.2			
	25	25.01			
	27	26.85			
	29	28.93			
	35	34.97			
	46	45.56			
3	51	50.89	0.7	1.1	1.6
	59	58.85			
	68	68.06			
	71	71.16			
	79	78.71			
	93	92.7			
	95	95.17			
	100	99.5			
	107	107.2			
	115	115.07			
	124	123.97			
	130	129.62			
	139	139.13			
	150	149.9			
	169	168.84			
	181	181.24			
195	195.26				
236	236.09				
308	307.54				
4	a richiesta	on request			

Rapporti preferenziali
Preferred ratios

Disponibile a 4 stadi con rapporti fino a 2076
Available 4 stages with ratio up to 2076

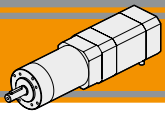

P52 con motore brushless

P52 with brushless motor

P52			BLS022.240													
			24V						36V							
Ns	ir	in	n _{2MIN} [rpm]			n _{2MAX} [rpm]			n _{1MAX} [rpm]	n _{2MIN} [rpm]			n _{2MAX} [rpm]			n _{1MAX} [rpm]
			M ₂ [Nm]	sf		M ₂ [Nm]	sf			M ₂ [Nm]	sf		M ₂ [Nm]	sf		
1	3.7	4	81	0.7	9.0	811	0.7	6.1	3000	108	0.7	9.0	1081	0.7	5.4	4000
	4.28	4	70	0.8	7.8	701	0.8	5.3		93	0.8	7.8	935	0.8	4.7	
	5.18	5	58	0.9	6.4	579	0.9	4.4		77	0.9	6.4	772	0.9	3.9	
	6.75	7	44	1.2	4.9	444	1.2	3.3		59	1.2	4.9	593	1.2	3.0	
13.73	14	22	2.3	7.6	218	2.3	5.2	29		2.3	7.6	291	2.3	4.6		
15.88	16	19	2.6	6.6	189	2.6	4.5	25		2.6	6.6	252	2.6	4.0		
18.36	18	16	3.0	5.7	163	3.0	3.9	22		3.0	5.7	218	3.0	3.4		
19.2	19	16	3.2	5.4	156	3.2	3.7	21		3.2	5.4	208	3.2	3.3		
22.2	22	14	3.7	4.7	135	3.7	3.2	18		3.7	4.7	180	3.7	2.8		
25.01	25	12	4.1	4.2	120	4.1	2.8	16		4.1	4.2	160	4.1	2.5		
26.9	27	11	4.4	3.9	112	4.4	2.6	15		4.4	3.9	149	4.4	2.3		
28.9	29	10	4.8	3.6	104	4.8	2.5	14		4.8	3.6	138	4.8	2.2		
35.0	35	8.6	5.8	3.0	86	5.8	2.0	11		5.8	3.0	114	5.8	1.8		
45.6	46	6.6	7.5	2.3	66	7.5	1.6	8.8		7.5	2.3	88	7.5	1.4		
50.9	51	5.9	8	4.7	59	7.8	3.2	7.9		8	4.7	79	7.8	2.8		
58.9	59	5.1	9	4.1	51	9.1	2.8	6.8		9	4.1	68	9.1	2.4		
68.1	68	4.4	10	3.5	44	10	2.4	5.9	10	3.5	59	10	2.1			
71.2	71	4.2	11	3.4	42	11	2.3	5.6	11	3.4	56	11	2.0			
78.7	79	3.8	12	3.0	38	12	2.1	5.1	12	3.0	51	12	1.8			
92.7	93	3.2	14	2.6	32	14	1.7	4.3	14	2.6	43	14	1.5			
95.2	95	3.2	15	2.5	32	15	1.7	4.2	15	2.5	42	15	1.5			
99.5	100	3.0	15	2.4	30	15	1.6	4.0	15	2.4	40	15	1.4			
107.2	107	2.8	17	2.2	28	17	1.5	3.7	17	2.2	37	17	1.3			
115.07	115	2.6	18	2.1	26	18	1.4	3.5	18	2.1	35	18	1.2			
123.97	124	2.4	19	1.9	24	19	1.3	3.2	19	1.9	32	19	1.2			
129.62	130	2.3	20	1.8	23	20	1.3	3.1	20	1.8	31	20	1.1			
139.13	139	2.2	21	1.7	22	21	1.2	2.9	21	1.7	29	21	1.0			
149.9	150	2.0	23	1.6	20	23	1.1	2.7	23	1.6	27	23	1.0			
168.84	169	1.8	26	1.4	18	26	1.0	2.4	26	1.4	24	26	0.8			
181.24	181	1.7	28	1.3	17	28	0.9	2.2	28	1.3	22	28	0.8			
195.26	195	1.5	30	1.2	15	30	0.8	2.0	30	1.2	20	30	0.7			
236.09	236	1.3	36	1.0	13	36	0.7	1.7	36	1.0	17	31	0.7			
307.54	308	1.0	47	0.8	9.8	36	0.7	1.3	47	0.8	13	31	0.7			

Rapporti preferenziali
Preferred ratios

Attenzione: superamento della coppia nominale supportata dal riduttore per servizio S1.
Contattare il ns. servizio tecnico
Attention: rated torque withstood by gear reducer for service in S1 is exceeded.
Please, contact our technical office.

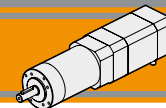

P52 con motore brushless

P52 with brushless motor

Tipo Type	Numero di poli Number of poles	Numero di fasi Number of phase	Tensione Rated voltage [V]	Numero di giri Rated speed [rpm]	Coppia nominale Rated torque [Nm]	Potenza nominale Rated power [W]
BLS022.240	4	3	36	4000	0.22	92
			24	3000		70
Tipo Type	Coppia massima Peak torque [Nm]	Corrente nominale Rated current [A]	Resistenza Resistance [ohm]	Induttanza Inductance [mH]	Corrente massima Peak current [A]	Peso Weight [kg]
BLS022.240	0.44	3.7	0.64	3.1	7.4	0.72



**P52..
+
BLS022.240**

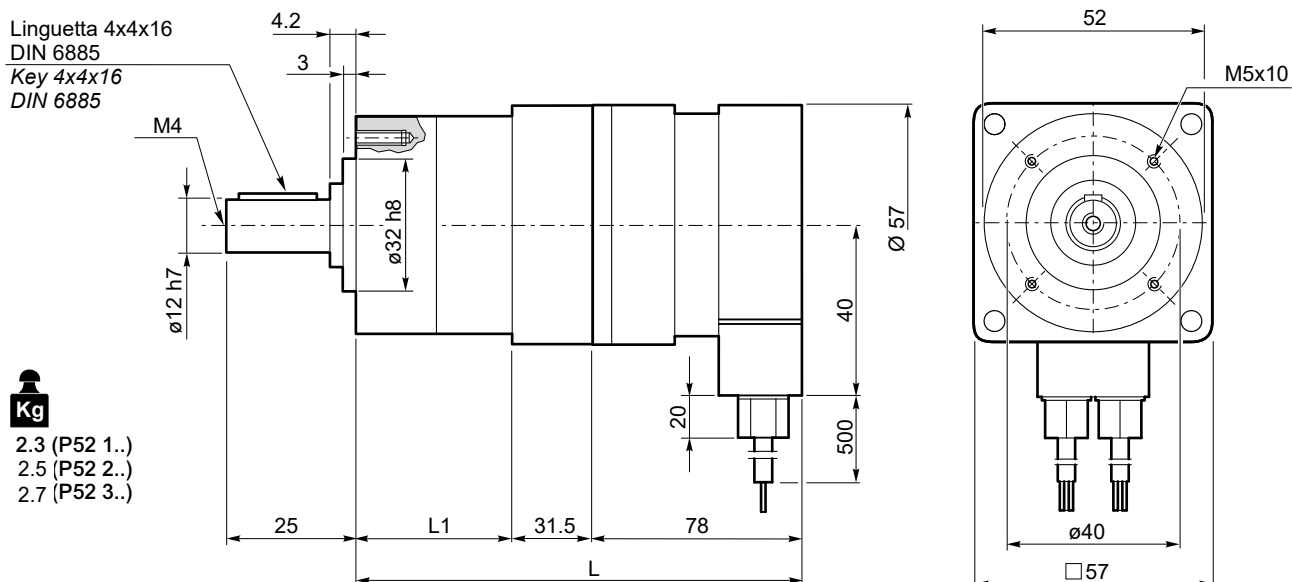

Kg
2.3 (P52 1..)
2.5 (P52 2..)
2.7 (P52 3..)

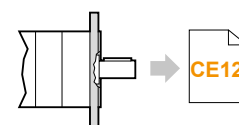

P52.. AS...

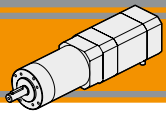

P52 con motore brushless

P52 with brushless motor

P52			BLS043.240														
			24V						36V								
Ns	ir	in	n _{2MIN} [rpm]			n _{2MAX} [rpm]			n _{1MAX} [rpm]	n _{2MIN} [rpm]			n _{2MAX} [rpm]			n _{1MAX} [rpm]	
			M ₂ [Nm]	sf		M ₂ [Nm]	sf			M ₂ [Nm]	sf		M ₂ [Nm]	sf			
1	3.7	4	81	1.3	4.6	811	1.3	3.1	3000	108	1.3	4.6	1081	1.3	2.8	4000	
	4.28	4	70	1.5	4.0	701	1.5	2.7		93	1.5	4.0	935	1.5	2.4		
	5.18	5	58	1.8	3.3	579	1.8	2.2		77	1.8	3.3	772	1.8	2.0		
	6.75	7	44	2.3	2.5	444	2.3	1.7		59	2.3	2.5	593	2.3	1.5		
2	13.73	14	22	4.4	3.9	218	4.4	2.6		29	4.4	3.9	291	4.4	2.3		
	15.88	16	19	5.1	3.4	189	5.1	2.3		25	5.1	3.4	252	5.1	2.0		
	18.36	18	16	5.9	2.9	163	5.9	2.0		22	5.9	2.9	218	5.9	1.7		
	19.2	19	16	6.2	2.8	156	6.2	1.9		21	6.2	2.8	208	6.2	1.7		
	22.2	22	14	7.2	2.4	135	7.2	1.6		18	7.2	2.4	180	7.2	1.4		
	25.01	25	12	8.1	2.1	120	8.1	1.5		16	8.1	2.1	160	8.1	1.3		
	26.9	27	11	8.7	2.0	112	8.7	1.4		15	8.7	2.0	149	8.7	1.2		
	28.9	29	10	9.3	1.8	104	9.3	1.3		14	9.3	1.8	138	9.3	1.1		
	35.0	35	8.6	11	1.5	86	11.3	1.0		11	11	1.5	114	11	0.9		
	45.6	46	6.6	15	1.2	66	14.7	0.8		8.8	15	1.2	88	15	0.7		
	3	50.9	51	5.9	15	2.4	59	15.3		1.6	7.9	15	2.4	79	15		1.4
		58.9	59	5.1	18	2.1	51	17.7		1.4	6.8	18	2.1	68	18		1.2
68.1		68	4.4	20	1.8	44	20	1.2	5.9	20	1.8	59	20	1.1			
71.2		71	4.2	21	1.7	42	21	1.2	5.6	21	1.7	56	21	1.0			
78.7		79	3.8	24	1.6	38	24	1.1	5.1	24	1.6	51	24	0.9			
92.7		93	3.2	28	1.3	32	28	0.9	4.3	28	1.3	43	28	0.8			
95.2		95	3.2	29	1.3	32	29	0.9	4.2	29	1.3	42	29	0.8			
99.5		100	3.0	30	1.2	30	30	0.8	4.0	30	1.2	40	30	0.7			
107.2		107	2.8	32	1.1	28	32	0.8	3.7	32	1.1	37	31	0.7			
115.07		115	2.6	35	1.1	26	35	0.7	3.5	35	1.1	35	31	0.7			
123.97		124	2.4	37	1.0	24	36	0.7	3.2	37	1.0	32	31	0.7			
129.62		130	2.3	39	0.9	23	36	0.7	3.1	39	0.9	31	31	0.7			
139.13		139	2.2	42	0.9	22	36	0.7	2.9	42	0.9	29	31	0.7			
149.9		150	2.0	45	0.8	20	36	0.7	2.7	45	0.8	27	31	0.7			
168.84		169	1.8	51	0.7	18	36	0.7	2.4	51	0.7	24	31	0.7			
181.24		181	1.7	53	0.7	17	36	0.7	2.2	53	0.7	22	31	0.7			
195.26	195	1.5	53	0.7	15	36	0.7	2.0	53	0.7	20	31	0.7				
236.09	236	1.3	53	0.7	13	36	0.7	1.7	53	0.7	17	31	0.7				
307.54	308	1.0	53	0.7	9.8	36	0.7	1.3	53	0.7	13	31	0.7				

Rapporti preferenziali
Preferred ratios

Attenzione: superamento della coppia nominale supportata dal riduttore per servizio S1.
Contattare il ns. servizio tecnico
Attention: rated torque withstood by gear reducer for service in S1 is exceeded.
Please, contact our technical office.

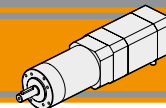

P52 con motore brushless

P52 with brushless motor

Tipo Type	Numero di poli Number of poles	Numero di fasi Number of phase	Tensione Rated voltage [V]	Numero di giri Rated speed [rpm]	Coppia nominale Rated torque [Nm]	Potenza nominale Rated power [W]
BLS043.240	4	3	36	4000	0.43	180
			24	3000		130
Tipo Type	Coppia massima Peak torque [Nm]	Corrente nominale Rated current [A]	Resistenza Resistance [ohm]	Induttanza Inductance [mH]	Corrente massima Peak current [A]	Peso Weight [kg]
BL043.240	0.86	6	0.35	1	12.0	1.25



**P52..
+
BLS043.240**

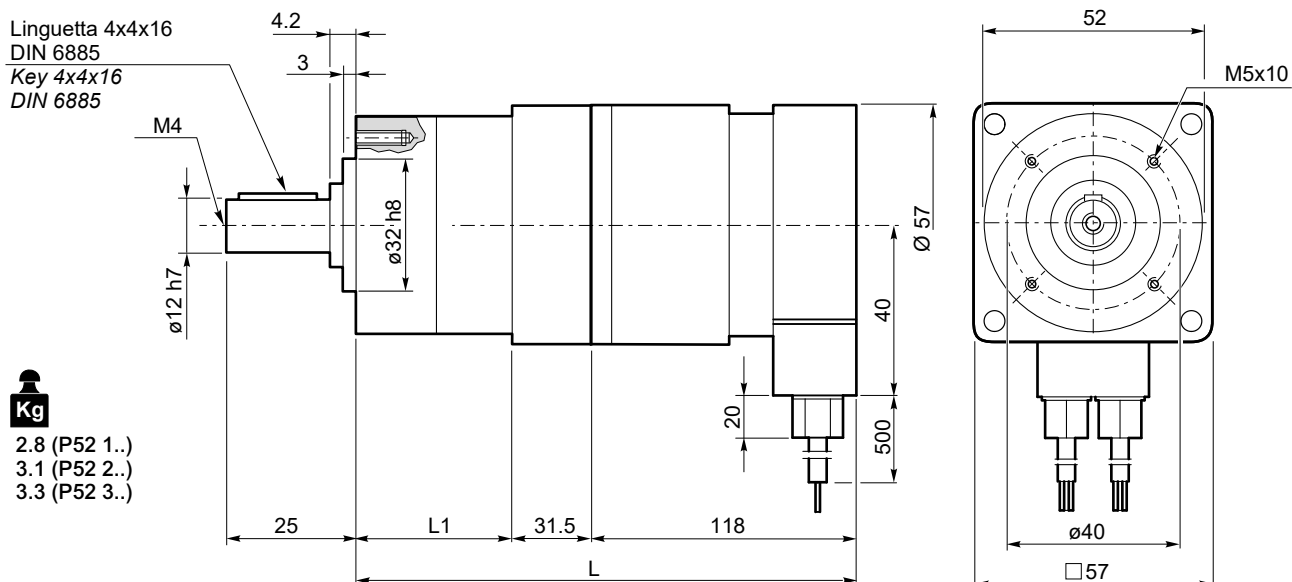

P52	BLS043.240		
	Ns	L1	L
	1	46	195.5
	2	60	209.5
	3	74	223.5

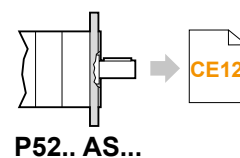

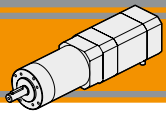

P62 con motore brushless

P62 with brushless motor

P62			BL070.480						BL140.480							
			48V						48V							
Ns	ir	in	n _{2MIN} [rpm]			n _{2MAX} [rpm]			n _{1MAX} [rpm]	n _{2MIN} [rpm]			n _{2MAX} [rpm]			n _{1MAX} [rpm]
			M ₂ [Nm]	sf		M ₂ [Nm]	sf			M ₂ [Nm]	sf		M ₂ [Nm]	sf		
1	3.7	4	81	2.1	5.6	811	2.1	3.8	3000	81	4.1	2.8	811	4.1	1.9	3000
	4.28	4	70	2.4	4.8	701	2.4	3.3		70	4.8	2.4	701	4.8	1.6	
	5.18	5	58	2.9	4.0	579	2.9	2.7		58	5.8	2.0	579	5.8	1.3	
	6.75	7	44	3.8	3.0	444	3.8	2.1		44	7.6	1.5	444	7.6	1.0	
2	13.73	14	22	7.2	5.1	218	7.2	3.5	3000	22	14.4	2.6	218	14.4	1.7	3000
	15.88	16	19	8.3	4.4	189	8.3	3.0		19	16.7	2.2	189	16.7	1.5	
	18.36	18	16	9.6	3.8	163	9.6	2.6		16	19.3	1.9	163	19.3	1.3	
	19.2	19	16	10	3.7	156	10	2.5		16	20	1.8	156	20	1.2	
	22.2	22	14	12	3.2	135	12	2.1		14	23	1.6	135	23	1.1	
	25.01	25	12	13	2.8	120	13	1.9		12	26	1.4	120	26	1.0	
	26.9	27	11	14	2.6	112	14	1.8		11	28	1.3	112	28	0.9	
	28.9	29	10	15	2.4	104	15	1.6		10	30	1.2	104	30	0.8	
	35.0	35	8.6	18	2.0	86	18	1.4		8.6	37	1.0	86	36	0.7	
	45.6	46	6.6	24	1.5	66	24	1.0		6.6	48	0.8	66	36	0.7	
	50.9	51	5.9	25	3.0	59	25	2.0		5.9	50	1.5	59	50	1.0	
	58.9	59	5.1	29	2.6	51	29	1.7		5.1	58	1.3	51	58	0.9	
3	68.1	68	4.4	33	2.2	44	33	1.5	3000	4.4	67	1.1	44	67	0.7	3000
	71.2	71	4.2	35	2.1	42	35	1.4		4.2	70	1.1	42	70	0.7	
	78.7	79	3.8	39	1.9	38	39	1.3		3.8	77	1.0	38	71	0.7	
	92.7	93	3.2	45	1.6	32	45	1.1		3.2	91	0.8	32	71	0.7	
	95.2	95	3.2	47	1.6	32	47	1.1		3.2	93	0.8	32	71	0.7	
	99.5	100	3.0	49	1.5	30	49	1.0		3.0	98	0.8	30	71	0.7	
	107.2	107	2.8	53	1.4	28	53	1.0		2.8	105	0.7	28	71	0.7	
	115.07	115	2.6	56	1.3	26	56	0.9		2.6	105	0.7	26	71	0.7	
	123.97	124	2.4	61	1.2	24	61	0.8		2.4	105	0.7	24	71	0.7	
	129.62	130	2.3	64	1.2	23	64	0.8		2.3	105	0.7	23	71	0.7	
	139.13	139	2.2	68	1.1	22	68	0.7		2.2	105	0.7	22	71	0.7	
	149.9	150	2.0	73	1.0	20	71	0.7		2.0	105	0.7	20	71	0.7	
168.84	169	1.8	83	0.9	18	71	0.7	1.8	105	0.7	18	71	0.7			
181.24	181	1.7	89	0.8	17	71	0.7	1.7	105	0.7	17	71	0.7			
195.26	195	1.5	96	0.8	15	71	0.7	1.5	105	0.7	15	71	0.7			
236.09	236	1.3	105	0.7	13	71	0.7	1.3	105	0.7	13	71	0.7			
307.54	308	1.0	105	0.7	9.8	71	0.7	1.0	105	0.7	9.8	71	0.7			

Rapporti preferenziali
Preferred ratios

Attenzione: superamento della coppia nominale supportata dal riduttore per servizio S1.
Contattare il ns. servizio tecnico
Attention: rated torque withstood by gear reducer for service in S1 is exceeded.
Please, contact our technical office.

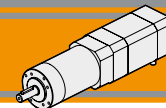

P62 con motore brushless

P62 with brushless motor

Tipo Type	Numero di poli Number of poles	Numero di fasi Number of phase	Tensione Rated voltage [V]	Numero di giri Rated speed [rpm]	Coppia nominale Rated torque [Nm]	Potenza nominale Rated power [W]
BL070.480	8	3	48	3000	0.70	220
BL140.480	8	3	48	3000	1.4	440
Tipo Type	Coppia massima Peak torque [Nm]	Corrente nominale Rated current [A]	Resistenza Resistance [ohm]	Induttanza Inductance [mH]	Corrente massima Peak current [A]	Peso Weight [kg]
BL070.480	1.4	6.5	0.34	1.0	13.0	2.1
BL140.480	2.8	13.0	0.16	0.5	26	3.15

Azionamenti
Drives



**P62..
+
BL070.480
BL140.480**

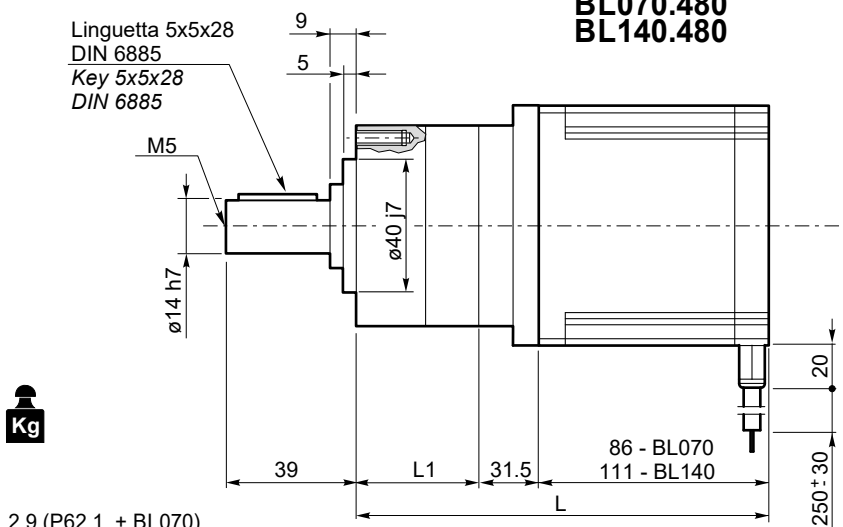

- 2.9 (P62 1..+ BL070)
- 3.3 (P62 2..+BL070)
- 3.7 (P62 3..+BL070)
- 3.9 (P62 1..+BL140)
- 4.3 (P62 2..+BL140)
- 4.7 (P62 3..+BL140)

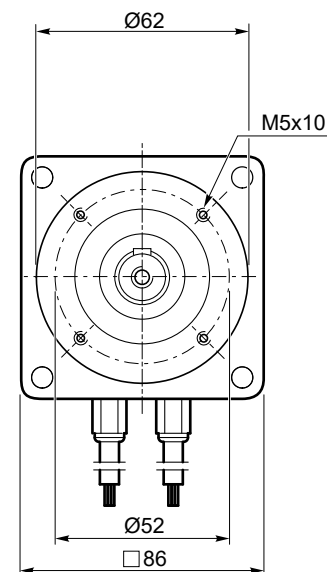

P62	Ns	L1	BL 070.480	BL 140.480
			L	L
	1	46	163.5	188.5
	2	62	179.5	204.5
	3	78	195.5	220.5

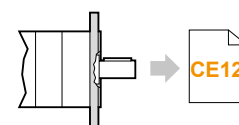

P62.. AS...

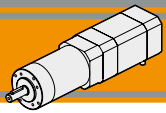

Dati tecnici

$n_1 = 3000$ rpm

Technical data

Ns	ir	in	P52			P62		
			R _d	M _{n2} [Nm]	R ₂ [N]	R _d	M _{n2} [Nm]	R ₂ [N]
1	3.70	4	0.80	4	200	0.80	8	240
	4.28	4						
	5.18	5						
	6.75	7						
2	13.73	14	0.75	12	320	0.75	25	360
	15.88	16						
	18.36	18						
	19.20	19						
	22.20	22						
	25.01	25						
	26.85	27						
	28.93	29						
	34.97	35						
45.56	46							
3	50.89	51	0.70	25	450	0.70	50	520
	58.85	59						
	68.06	68						
	71.16	71						
	78.71	79						
	92.70	93						
	95.17	95						
	99.50	100						
	107.20	107						
	115.07	115						
	123.97	124						
	129.62	130						
	139.13	139						
	149.90	150						
	168.84	169						
181.24	181							
195.26	195							
236.09	236							
307.54	308							

Rapporti preferenziali per le taglie P52 e P62.
Preferred ratios for sizes P52 e P62.

Disponibili 4 stadi con rapporti fino a 2076 / Available 4 stages with ratio up to 2076

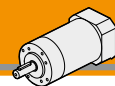

Dimensioni P con flange motore AS

P dimensions with motor flanges AS

P52 - U - AS...

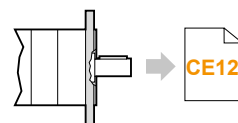
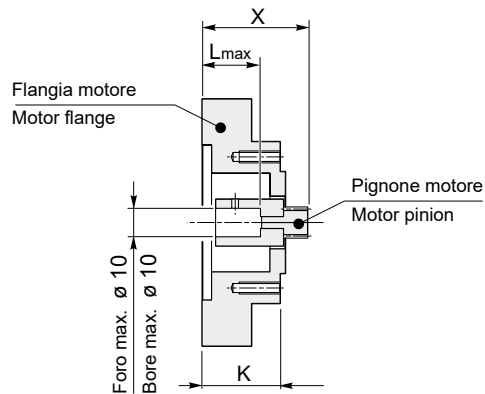
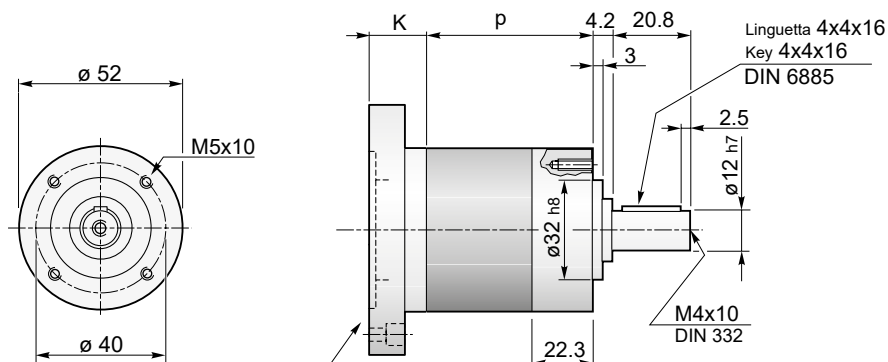

P52.. C...

Lo spessore della flangia è variabile in funzione delle diverse lunghezze dell'albero motore.

Flange's thickness may vary depending on motorshaft's length.

Dimensioni / Dimensions							
AS	A	B	C	M	K	L _{max}	X
AS394	38.1	47.1	57	M5	31.5	23	41.5
...

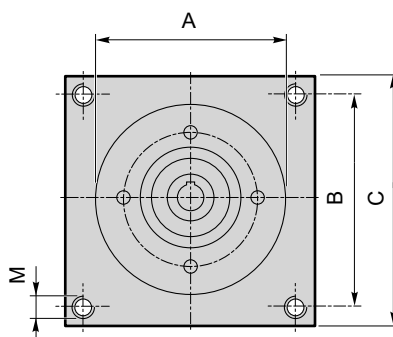

		Lunghezza riduttore Gearbox length	
		P	
P52...	1	46	0.7
	2	60	0.9
	3	74	1.1

P62 - U - AS...

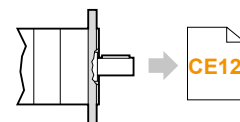
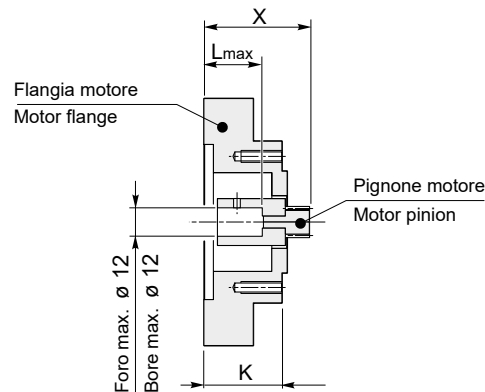
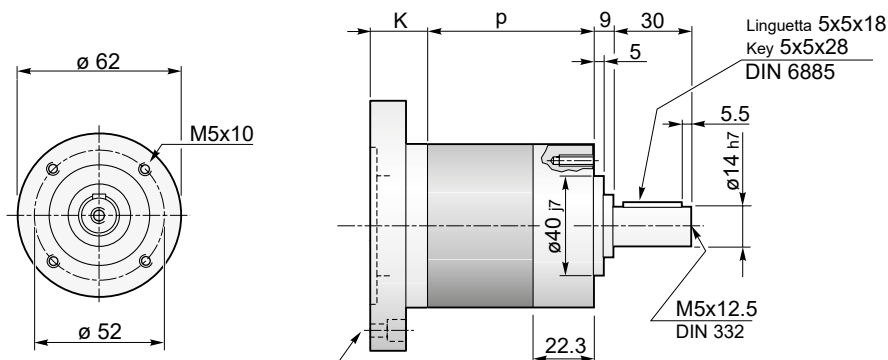

P62.. C...

Lo spessore della flangia è variabile in funzione delle diverse lunghezze dell'albero motore.

Flange's thickness may vary depending on motorshaft's length.

Dimensioni / Dimensions							
AS	A	B	C	M	K	L _{max}	X
AS389	73	69.6	86	M5	31.5	23	44.3
...

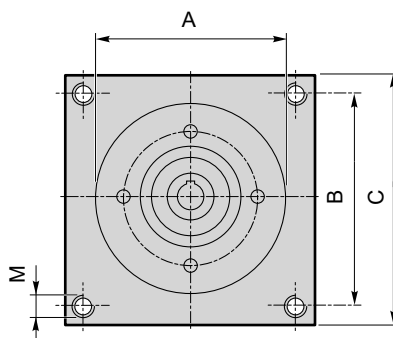

		Lunghezza riduttore Gearbox length	
		P	
P62...	1	46	0.8
	2	62	1.2
	3	78	1.6

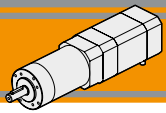

Dimensioni flange uscita

Output flange dimensions

P.. C..

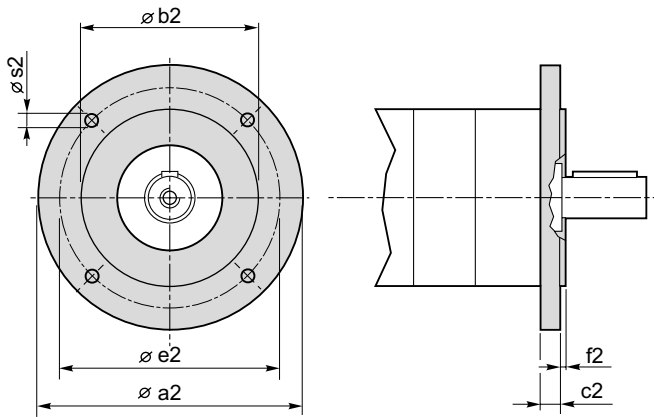

Flange uscita / Output flanges							
P	a2	b2	c2	e2	f2	s2	Flangia Flange
52	80	50 j7	9	65	2.5	M5	C80
	90	60 j7	9	75	2.5	5.5	C90
	105	70 j7	9	85	2.5	6.5	C105
	120	80 j7	9	100	3.0	6.5	C120
62	80	50 j7	9	65	2.5	M5	C80
	90	60 j7	9	75	2.5	5.5	C90
	105	70 j7	9	85	2.5	6.5	C105
	120	80 j7	9	100	3.0	6.5	C120

Azionamenti per motori brushless CC
Brushless DC motor controls





	Indice	Index	Pag. Page
	Selezione azionamento Selezione azionamento per motori Brushless	Drive selection <i>Brushless motor drive selection guide</i>	CF1
BLD07-IT	AZIONAMENTO 4Q PER MOTORI BRUSHLESS CC	4Q DRIVE FOR DC BRUSHLESS MOTORS	
	Caratteristiche tecniche	<i>Technical features</i>	CF2
	Dimensioni	<i>Dimensions</i>	CF2
	Collegamenti	<i>Connections</i>	CF3
BLD15	AZIONAMENTO 4Q PER MOTORI BRUSHLESS CC	4Q DRIVE FOR DC BRUSHLESS MOTORS	
	Caratteristiche tecniche	<i>Technical features</i>	CF5
	Dimensioni	<i>Dimensions</i>	CF6
	Collegamenti	<i>Connections</i>	CF7
BLDCXL65 - 20	AZIONAMENTO 4Q PER MOTORI BRUSHLESS CC	4Q DRIVE FOR DC BRUSHLESS MOTORS	
	Caratteristiche standard	<i>Standard characteristic</i>	CF9
	Dati tecnici principali	<i>Specifications</i>	CF9
	Dimensioni	<i>Dimensions</i>	CF10
	Collegamenti per motore Brushless serie BL	<i>Connections for Brushless motor BL series</i>	CF10

SELEZIONE AZIONAMENTO

DRIVE SELECTION

Selezione azionamento per motore brushless

Brushless motor drive selection guide

Motori applicabili <i>Suitable motors</i>	Scheda / <i>Type</i>	Corrente Nominale / <i>Rated Current</i> (A)	Corrente di Picco / <i>Peak Current</i> (A)
BLS022.240	BLD07-IT	7	14
BLS043.240	BLD07-IT	7	14
BL070.480	BLD15	15	30
BL140.480	BLD15	15	30
BL210.480	BLDCXL65 - 20	20	40

Questa sezione annulla e sostituisce ogni precedente edizione o revisione. Qualora questa sezione non Vi sia giunta in distribuzione controllata, l'aggiornamento dei dati ivi contenuto non è assicurato. **In tal caso la versione più aggiornata è disponibile sul nostro sito internet www.transtecno.com**

This section replaces any previous edition and revision. If you obtained this catalogue other than through controlled distribution channels, the most up to date content is not guaranteed. In this case the latest version is available on our web site www.transtecno.com

**BLD07-IT****AZIONAMENTO 4Q
PER MOTORI BRUSHLESS CC****4Q DRIVE
FOR DC BRUSHLESS MOTORS**

L'azionamento BLD07-IT è la nuova e aggiornata versione della precedente BLD07. Realizzato su una nuova PCB, sono state implementate caratteristiche e funzionalità che prima si potevano ottenere solo con drive di potenze superiori.

Il risultato è quello di avere un drive più versatile e all'avanguardia, che può essere customizzato, oppure comandato via bus di campo (CAN Open opzionale).

The BLD07-IT drive is the new and updated version of the previous BLD07. Built on a new PCB, features and functionality have been implemented, where previously could only be achieved with higher power drive.

The result is to have a more versatile drive and to 'cutting edge, which can be customized, or controlled via the field bus (CAN Open optional).

Caratteristiche standard**Standard features**

- Azionamento bidirezionale rigenerativo
 - Alimentazione singola CC
 - 3 Leds per la diagnostica (stato ed allarmi)
 - Protetto per corto circuito, min/max tensione, mancanza celle di Hall
 - Protezione termica motore Ixt
 - Connettori estraibili (segnali e potenza)
 - Comando di velocità analogico 0 +10Vcc e PWM
 - 4 Ingressi digitali – optoisolati
 - 2 Uscite NPN - allarmi e frequenza di lavoro
 - Regolazione rampa di accelerazione
- Bidirectional regenerative operation
 - Single supply DC voltage
 - 3 diagnostic Leds (State and Alarms)
 - Protections for: Over/Under voltage,
 - Over current, Hall missing
 - Ixt motor current protection
 - Power and signals extractable connectors
 - Analog speed command 0 + 10Vdc and PWM
 - 4 Digital inputs – optoisolated
 - 2 NPN - fault drive and running frequency
 - Acceleration adjustment

Dati tecnici principali**Specifications**

- Idoneo per motori BLDC trifase 4/8 poli
 - Retroazione digitale sensori di Hall
 - Frequenza PWM 20 KHz
 - Temperatura operativa 0/+40°C
 - Ingresso analogico 0/+10Vcc
 - Rampa accelerazione regolabile 0.1/1.0sec (tramite dip switch)
 - Regolazione corrente max
 - Regolazione della velocità (potenziometro esterno o interno) esterno 10KΩ
- Suitable for 3ph BLDC motors 4/8 poles
 - Digital feedback Hall sensors
 - PWM frequency 20 KHz
 - Operative temperature 0/+40°C
 - Analog inputs range 0/+10Vdc
 - Acceleration ramp adjustable 0.1/1.0sec (by dip switch)
 - Current max regulation
 - Speed change regulation external 10KΩ (by external or internal pot)

MODELLO / MODEL		BLD07-IT
Tensione nominale motore <i>Motor DC Voltage</i>	(Vdc)	24 - 36
Tensione di alimentazione min / max <i>Supply DC Voltage Range min / max</i>	(Vdc)	20-40
Corrente nominale <i>Rated Current</i>	(A)	7
Corrente di picco (1) <i>Peak Current</i>	(A)	14
Potenza nominale (2) <i>Rated Power</i>	(W)	230
Potenza di picco (3) <i>Peak Power</i>	(W)	460

(1) La corrente di picco viene erogata per un tempo di circa 2 secondi
(1) *Peak current (Adc) for 2 sec.*

(2) La potenza nominale è riferita al valore di tensione e di corrente nominale
(2) *Power of amplifier at the rated current and rated voltage*

(3) La potenza di picco è riferita al valore di tensione nominale e di corrente di picco
(3) *Power of amplifier at the peak current and rated voltage*



BLD07-IT

**AZIONAMENTO 4Q
PER MOTORI BRUSHLESS CC**

**4Q DRIVE
FOR DC BRUSHLESS MOTORS**

Dimensioni

Dimensions

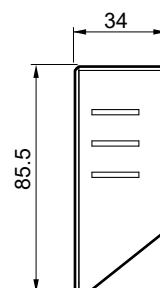
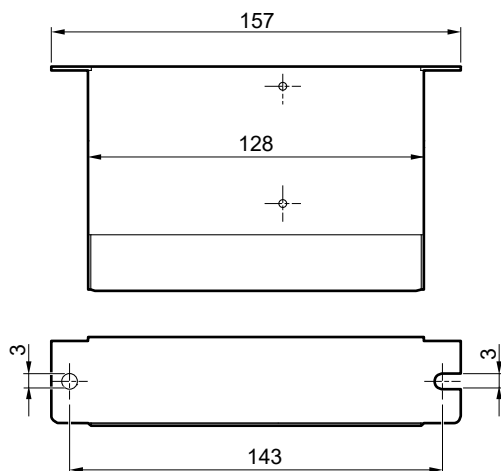

Collegamenti

Connections

L'azionamento BLD07-IT è dotato di:

- connettore estraibile a 5 morsetti per la parte di potenza;
- tre connettori estraibili, per un totale di 16 morsetti, per la gestione dei segnali in ingresso ed in uscita.

The BLD07-IT drive is equipped with:

- removable connector with 5 terminals for the power part;
- 3 removable connectors, for a total of 16 terminals, for the management of the input and output signal.

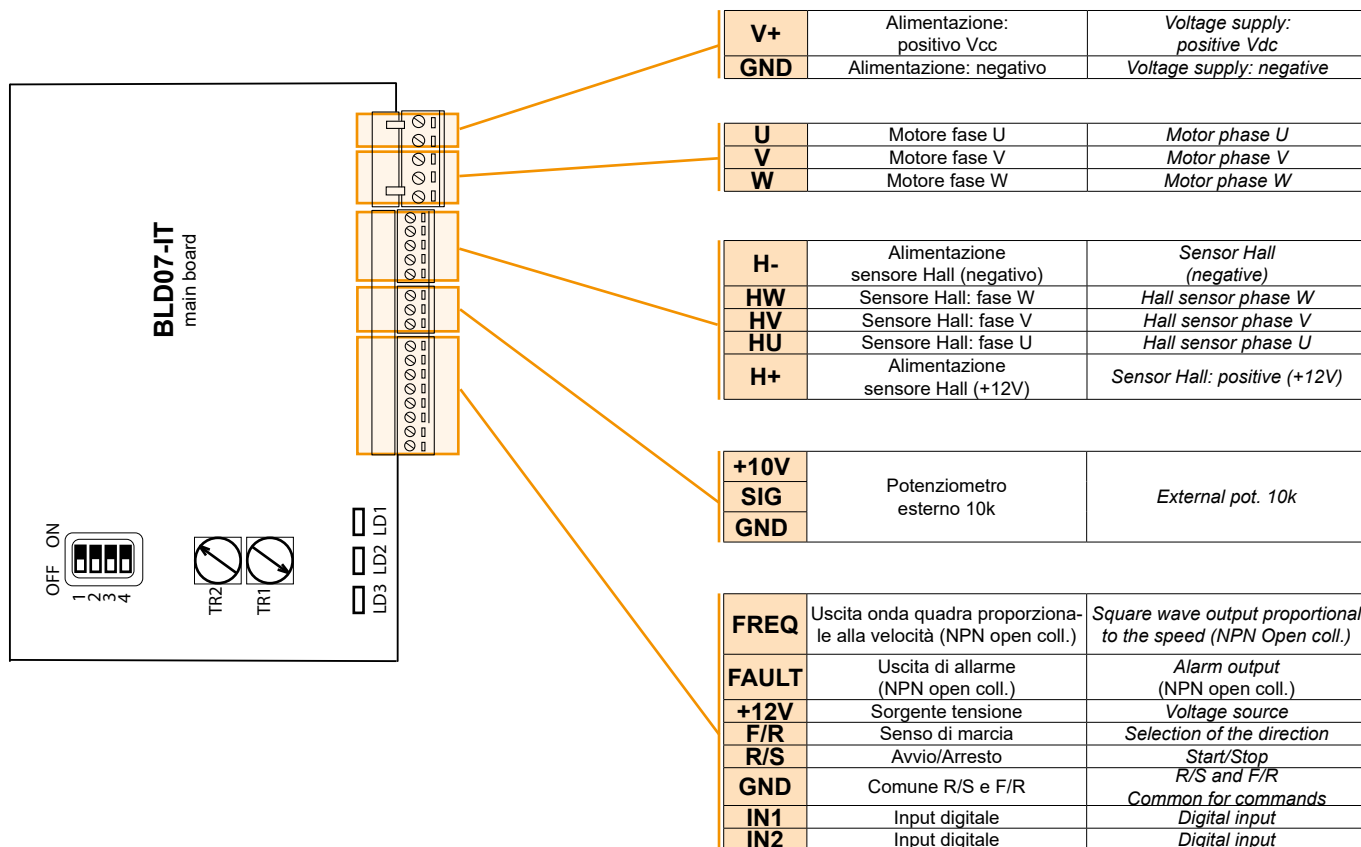



BLD07-IT

**AZIONAMENTO 4Q
PER MOTORI BRUSHLESS CC**

**4Q DRIVE
FOR DC BRUSHLESS MOTORS**

Collegamenti

Connections

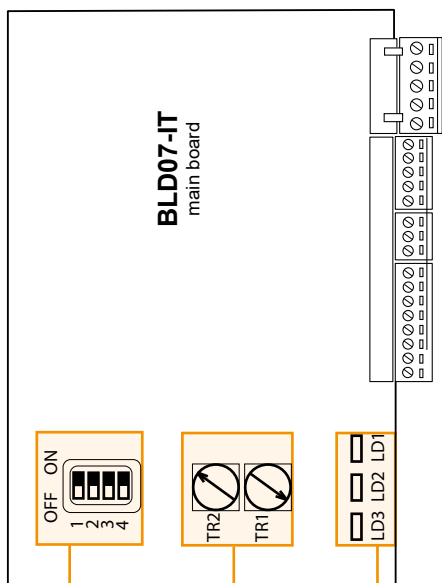

Led		
LD1	Verde - power ON	Green - power ON
LD2	Rosso - allarme in corso	Red - alarm
LD3	Giallo - superamento corrente max.	Yellow - the drive is in limit of current
Presenti 2 Leds per la chiusura dei contatti R/S e F/R		2 LEDs for the closing of R/S and F/R

Trimmer		
TR1	Regolazione velocità (crescente con rotazione oraria)	External speed pot (clockwise to increase)
TR2	Limitazione corrente (crescente con rotazione antioraria)	Current limitation (counter clockwise to increase)

Dip Switch		
1	OFF = Controllo velocità da pot. interno TR1	Internal speed pot TR1
	ON = Controllo velocità da pot. esterno o segnale analogico 0/+10V	External speed pot or analog signal 0/+10V
2	OFF = Funzionamento in anello chiuso	Operating in closed loop
	ON = Funzionamento in anello aperto	Operating in open loop
3	OFF = Rampe rapide (0.1 sec)	Fast Acceleration (about 0.1 sec)
	ON = Rampe lente (1.0 sec)	Slow acceleration (about 1.0 sec)
4	OFF = per motori a 4 poli	4 poles motors
	ON = per motori a 8 poli	8 poles motors



BLD15

**AZIONAMENTO 4Q
PER MOTORI BRUSHLESS CC**

**4Q DRIVE
FOR DC BRUSHLESS MOTORS**

L'azionamento BLD15 è la versione di maggiore potenza della BLD07-IT realizzato su una nuova PCB, dove sono state implementate nuove caratteristiche e funzionalità. Il risultato è quello di avere un drive più versatile e all'avanguardia, che può essere customizzato e opzionalmente può essere gestito in coppia oppure comandato in via bus di campo, ModBus RTU RS485 oppure CANOpen DS301.

The BLD15 drive is the most powerful version of the BLD07-IT built on a new PCB, new features and functionality have been implemented. The result is that of having a more versatile and avant-garde drive, which can be customized, the possibility of having the drive in a torque version or controlled via fieldbus, Modbus RTU RS485 or CANOpen DS301.

Caratteristiche standard

Standard features

- | | |
|--|---|
| <ul style="list-style-type: none"> ● Azionamento bidirezionale rigenerativo ● Alimentazione singola CC ● 3 Leds per la diagnostica (stato ed allarmi) ● Protetto per corto circuito, min/max tensione, mancanza celle di Hall ● Protezione termica motore Ixt ● Connettori estraibili (segnali e potenza) ● Comando di velocità analogico 0 +10Vcc e PWM ● 4 Ingressi digitali – optoisolati ● 2 Uscite NPN - allarmi e frequenza di lavoro ● Regolazione rampa di accelerazione ● Versione TORQUE control ● Versione ModBus RTU RS485 ● Versione CANOpen DS301 | <ul style="list-style-type: none"> ● Bidirectional regenerative operation ● Single supply DC voltage ● 3 diagnostic Leds (State and Alarms) ● Protections for: Over/Under voltage, Over current, Hall missing ● Ixt motor current protection ● Power and signals extractable connectors ● Analog speed command 0 + 10Vdc and PWM ● 4 Digital inputs – optoisolated ● 2 NPN - fault drive and running frequency ● Acceleration adjustment ● TORQUE control version ● ModBus RTU RS485 version ● CANOpen DS301 version |
|--|---|

Dati tecnici principali

Specifications

- | | |
|--|--|
| <ul style="list-style-type: none"> ● Idoneo per motori BLDC trifase 4/8 poli ● Retroazione digitale sensori di Hall ● Frequenza PWM 20 KHz ● Temperatura operativa 0/+40°C ● Ingresso analogico 0/+10Vcc ● Rampa accelerazione regolabile (tramite dip switch) 0.1/1.0sec ● Regolazione corrente max ● Regolazione della velocità (potenziometro esterno o interno) esterno 10KΩ | <ul style="list-style-type: none"> ● Suitable for 3ph BLDC motors 4/8 poles ● Digital feedback Hall sensors ● PWM frequency 20 KHz ● Operative temperature 0/+40°C ● Analog inputs range 0/+10Vdc ● Acceleration ramp adjustable (by dip switch) 0.1/1.0sec ● Current max regulation ● Speed change regulation (by external or internal pot) external 10KΩ |
|--|--|

MODELLO / MODEL		BLD15
Tensione nominale motore <i>Motor DC Voltage</i>	(Vdc)	24 - 36 - 48
Tensione di alimentazione min / max <i>Supply DC Voltage Range min / max</i>	(Vdc)	20-65
Corrente nominale <i>Rated Current</i>	(A)	15
Corrente di picco (1) <i>Peak Current</i>	(A)	30
Potenza nominale (2) <i>Rated Power</i>	(W)	650
Potenza di picco (3) <i>Peak Power</i>	(W)	1300

(1) La corrente di picco viene erogata per un tempo di circa 2 secondi
(1) *Peak current (A_{dc}) for 2 sec.*

(2) La potenza nominale è riferita al valore di tensione e di corrente nominale
(2) *Power of amplifier at the rated current and rated voltage*

(3) La potenza di picco è riferita al valore di tensione nominale e di corrente di picco
(3) *Power of amplifier at the peak current and rated voltage*



BLD15

**AZIONAMENTO 4Q
PER MOTORI BRUSHLESS CC**

**4Q DRIVE
FOR DC BRUSHLESS MOTORS**

Dimensioni

Dimensions

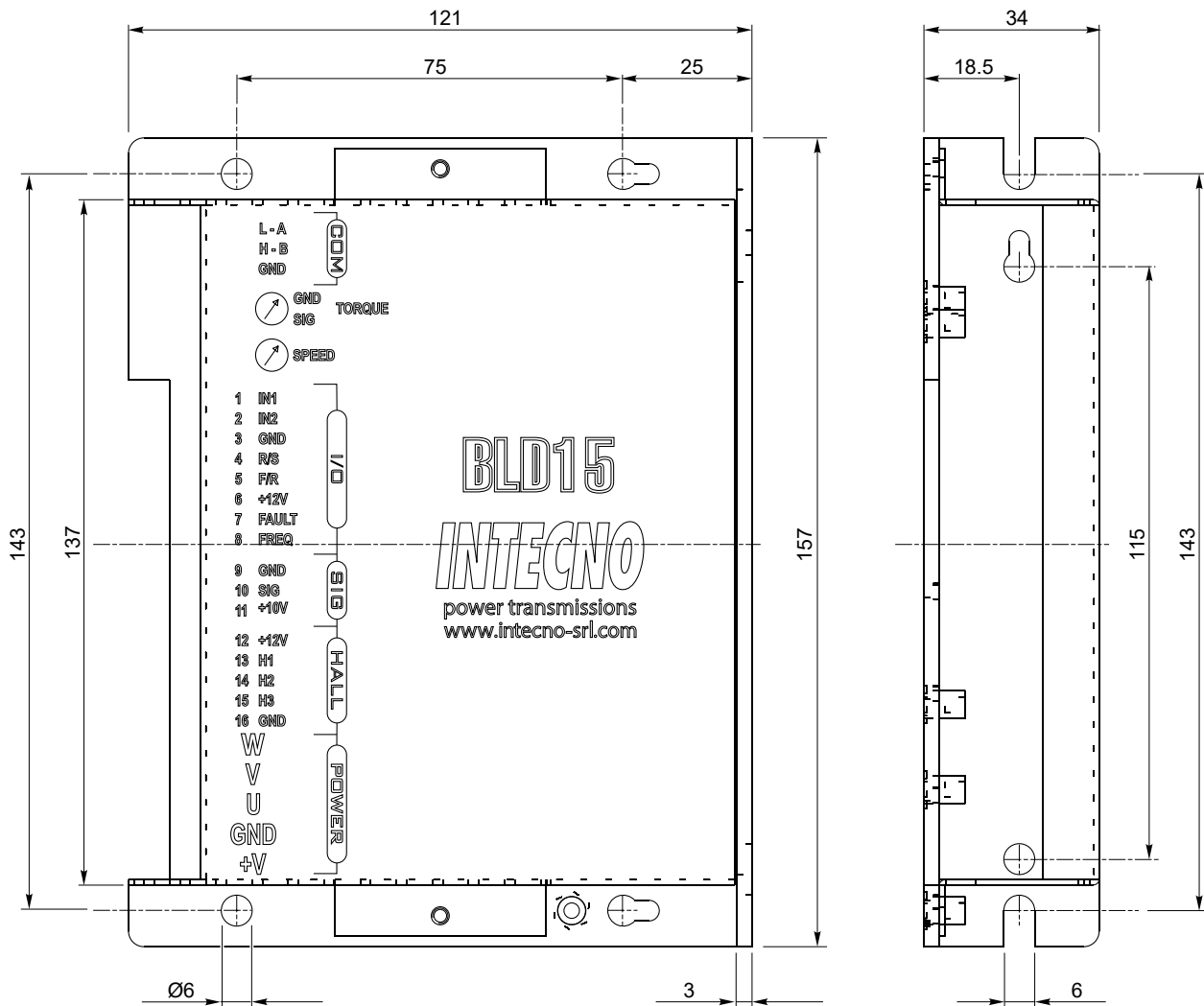



BLD15

**AZIONAMENTO 4Q
PER MOTORI BRUSHLESS CC**

**4Q DRIVE
FOR DC BRUSHLESS MOTORS**

Collegamenti

Connections

L'azionamento BLD15 è dotato di:

- connettore estraibile a 5 morsetti per la parte di potenza;
- tre connettori estraibili, per un totale di 16 morsetti, per la gestione dei segnali in ingresso ed in uscita.

Versione TORQUE

- connettore estraibile a 2 morsetti
- **Versione ModBus/CANOpen**
- connettore estraibile a 3 morsetti

The BLD15 drive is equipped with:

- removable connector with 5 terminals for the power part;
- 3 removable connectors, for a total of 16 terminals, for the management of the input and output signal.

TORQUE Version

- removable connector with 2 terminals
- **ModBus/CANOpen Version**
- removable connector with 3 terminals

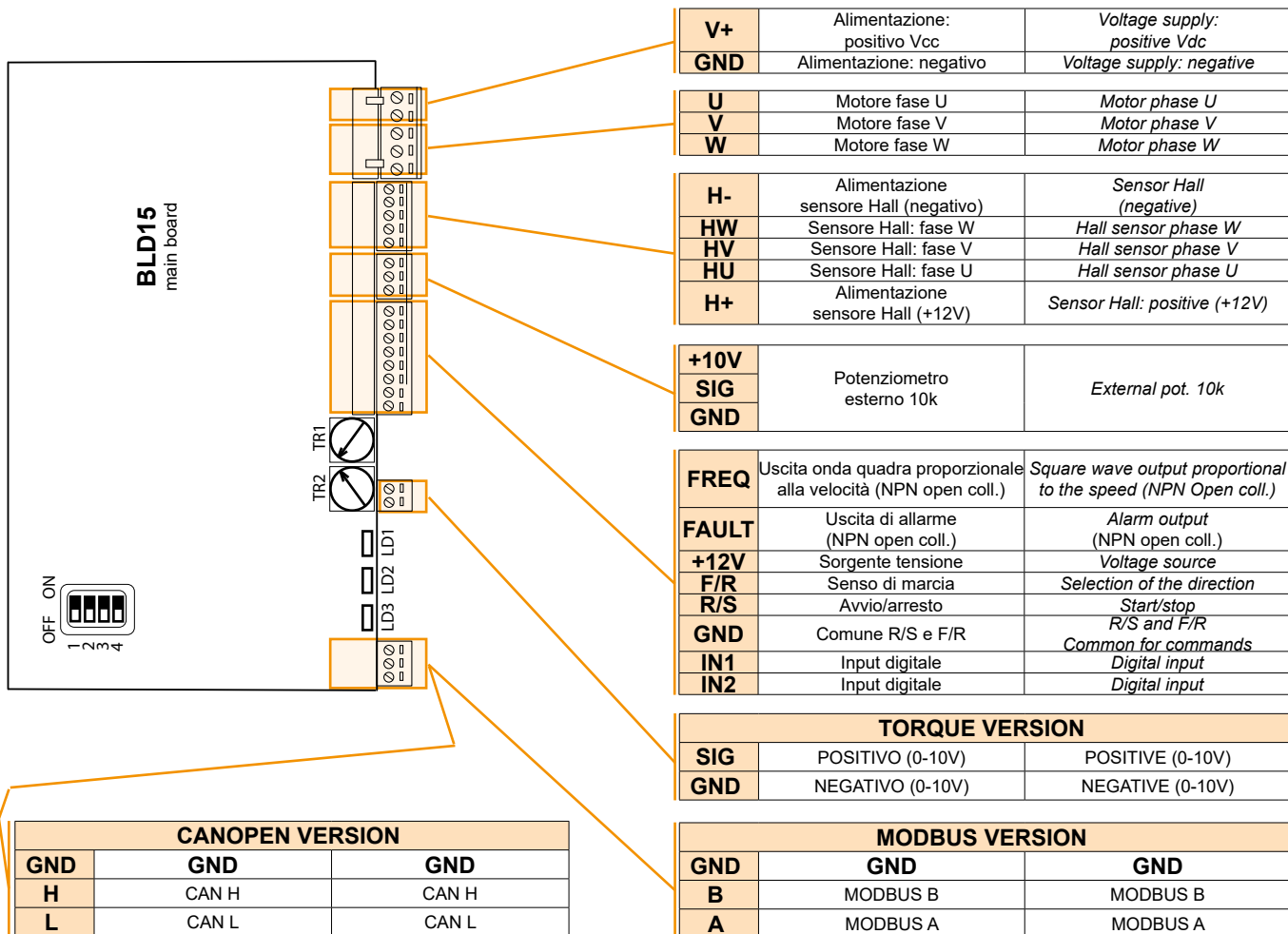



BLD15

**AZIONAMENTO 4Q
PER MOTORI BRUSHLESS CC**

**4Q DRIVE
FOR DC BRUSHLESS MOTORS**

Collegamenti

Connections

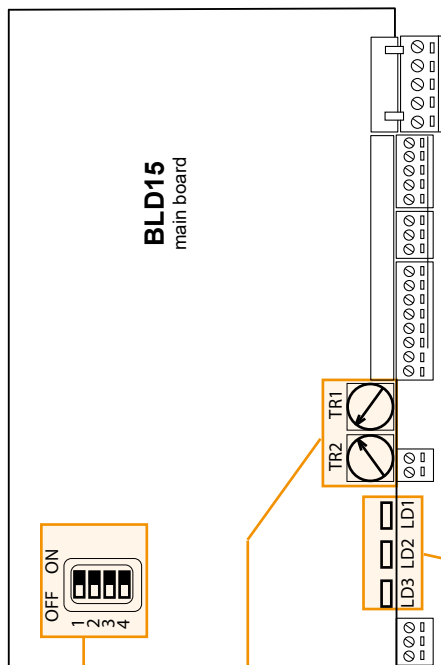

Led		
LD1	Verde - power ON	Green - power ON
LD2	Rosso - allarme in corso	Red - alarm
LD3	Giallo - superamento corrente max.	Yellow - the drive is in limit of current
Presenti 2 Leds per la chiusura dei contatti R/S e F/R		2 LEDs for the closing of R/S and F/R

Trimmer		
TR1	Regolazione velocità (crescente con rotazione oraria)	External speed pot (clockwise to increase)
TR2*	Limitazione corrente (crescente con rotazione antioraria)	Current limitation (counter clockwise to increase)

(*) Non presente con versione torque

(*) Not designed for torque version

Dip Switch		
1	OFF = Controllo velocità da pot. interno TR1	Internal speed pot TR1
	ON = Controllo velocità da pot. esterno o segnale analogico 0/+10V	External speed pot or analog signal 0/+10V
2	OFF = Funzionamento in anello chiuso	Operating in closed loop
	ON = Funzionamento in anello aperto	Operating in open loop
3	OFF = Rampe rapide (0.1 s)	Fast Acceleration (about 0.1 sec)
	ON = Rampe lente (1.0 s)	Slow acceleration (about 1.0 sec)
4	OFF = per motori a 4 poli	4 poles motors
	ON = per motori a 8 poli	8 poles motors



BLDCXL65 - 20

**AZIONAMENTO 4Q
PER MOTORI BRUSHLESS CC**

**4Q DRIVE
FOR DC BRUSHLESS MOTORS**

Caratteristiche standard

Standard characteristic

- **Convertitore trifase a quattro quadranti per motori Brushless**
- Alimentazione singola DC
- 5 Leds per la diagnostica (stato ed allarmi)
- Protetto per corto circuito, min/max tensione, sovratemperatura, mancanza celle di hall.
- Protezione termica motore Ixt
- Connettori estraibili 16 vie (segnali) e 5 vie (potenza)
- 1 Comando di velocità differenziale analogico +/-10V
- 1 Comando di coppia analogico +/-10V per realizzare avvitatori, svolgitori, macchine test, ecc
- Feedback da sensori di HALL
- 1 Uscita NPN segnalazione allarme azionamento
- 4 trimmers di regolazione (velocità, offset, guadagni).

- **Four quadrant regenerative operation for Brushless motor**
- **Single supply DC voltage**
- **5 diagnostic Leds (State and Alarms)**
- **Protections for: Over/Under voltage, max. temperature, Over current**
- **Ixt motor current**
- **Power and signals extractable connectors (16 ways and 5 ways)**
- **1 Differential velocity input +/-10V**
- **1 Torque mode (demand current) input +/-10V**
- **Feedback by HALL sensors**
- **NPN Fault drive output**
- **Four Potentiometer adjustments (Speed, offset, gain, derivative)**

Dati tecnici principali

Specifications

- Tensione d'uscita massima 0,9 Vcc ingresso
- Frequenza PWM 20Khz
- Temperatura operativa 0/+45°C
- Ingressi analogici +/-10Vdc
- Monitor di corrente +/- 8Vdc=I di picco
- Alimentazione d'uscita encoder +5Vcc @130 mA
- Alimentazioni d'uscita ausiliarie +/-10Vcc @ 4mA
- Frequenza massima encoder 300Khz
- Livello logico ingresso encoder $\geq +2,8V/+24V$ min/max
- Segnale (Start) di abilitazione +9V/+30Vcc max
- Banda passante (anello corrente) 2KHz
- Banda passante (anello di vel.) 150Hz
- Induttanza minima motore 400uH
- Grado inquinamento 2° o migliore

- **Output voltage 0,9 Vdc Input**
- **PWM frequency 20Khz**
- **Operative temperature 0/+45°C**
- **Analog inputs range +/-10Vdc**
- **Current monitor +/- 8Vdc (At peak curr.)**
- **Encoder power supply +5Vdc @130mA**
- **Ausiliary power supply +/-10Vdc @ 4mA**
- **Maximum encoder frequency 300Khz**
- **Logic level encoder inputs $\geq +2,8V/+24V$ min/max**
- **Start signal (Input range) +9V/+30Vdc**
- **Current loop bandwidth 2KHz**
- **Velocity loop bandwidth 150Hz**
- **Minimum motor inductance 400uH**
- **Polution degree 2° or better**

Dimensioni

Dimensions

MODELLO / MODEL		65 - 20
Tensione nominale DC Voltage Supply	(V)	48
Tensione min / max DC Voltage Range	(V)	19 - 84
Corrente nominale Rated Current	(A)	20
Corrente di picco (1) Peak Current	(A)	40
Potenza nominale (2) Rated Power	(W)	1160
Potenza di picco (3) Peak Power	(W)	2120

(1) La corrente di picco viene erogata per un tempo di circa 2 secondi
(1) *Peak current (Adc) for 2 sec.*

(2) La potenza nominale è riferita al valore di tensione e di corrente nominale
(2) *Power of amplifier at the rated current and rated voltage*

(3) La potenza di picco è riferita al valore di tensione nominale e di corrente di picco
(3) *Power of amplifier at the peak current and rated voltage*

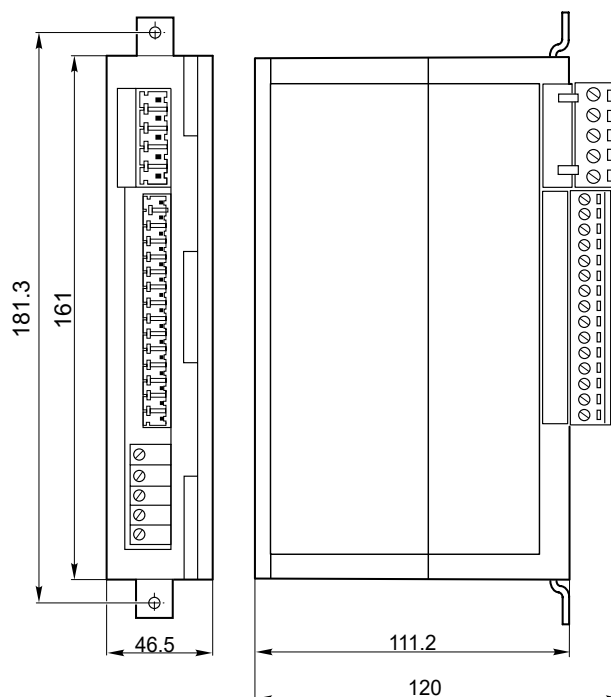



BLDCXL65 - 20

AZIONAMENTO 4Q PER MOTORI BRUSHLESS CC

4Q DRIVE FOR DC BRUSHLESS MOTORS

Collegamenti per motori brushless serie BL

Connections for brushless motors BL series

Fili di potenza:

- Blu grosso - fase motore U: pin U
- Marrone grosso - fase motore V: pin V
- Nero grosso - fase motore W: pin W

Power wires:

- Blue big - phase motor U: pin U
- Brown big - phase motor V: pin V
- Black big - phase motor W: pin W

Fili di segnale:

- Rosso piccolo (+Vcc): pin 12
- Nero piccolo (GND): pin 13
- Blue (hall U): pin 14
- Verde (hall V): pin 15
- Bianco (hall W): pin 16

Fili di segnale:

- Red small (+Vcc): pin 12
- Black small (GND): pin 13
- Blue (hall U): pin 14
- Green (hall V): pin 15
- White (hall W): pin 16

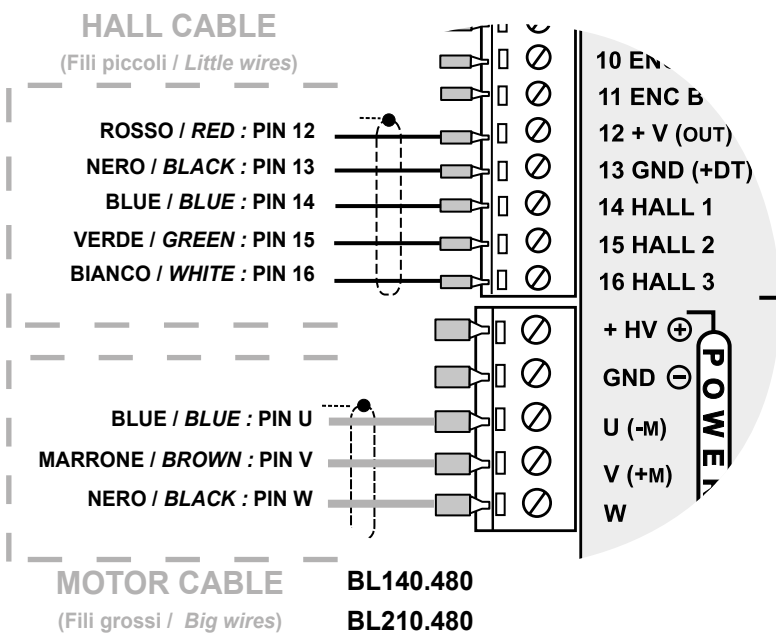
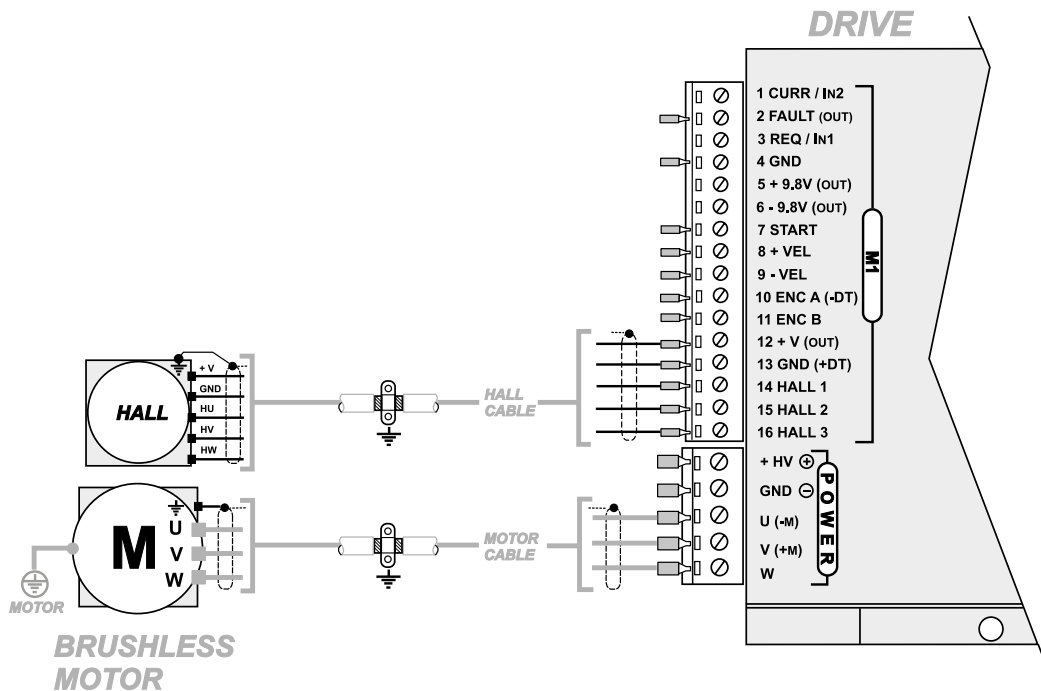

MOTOR CABLE BL140.480
(Fili grossi / Big wires) BL210.480

**MA TRANSTECNO S.A.P.I. DE C.V.**

Av. Mundial # 176, Parque Industrial
JM Apodaca, Nuevo León,
C.P. 66600
MÉXICO
T +52 8113340920
info@transtecno.com.mx
www.transtecno.com.mx

**TRANSTECNO SRL**

Via Caduti di Sabbiuno, 11/D-E
40011 Anzola dell'Emilia (BO)
ITALY
T+39 051 64 25 811
F +39 051 73 49 43
sales@transtecno.com
www.transtecno.com

**HANGZHOU TRANSTECNO POWER TRANSMISSIONS CO LTD**

No.4 Xiuyan Road Fengdu Industry Zone
Pingyao Town Yuhang District
Hangzhou City, Zhejiang Province
311115 – CHINA
T +86 571 86 92 02 60
F +86 571 86 92 18 10
info-china@transtecno.com
www.transtecno.cn

**TRANSTECNO U.S.A. LLC**

5440 S.W. 156th Place Miami,
FL 33185 - USA
Tel: +1 (305) 220-4423
Fax: +1 (305) 220-5945
usaoffice@transtecno.com

**TRANSTECNO B.V.**

Ind. terrein Wieken/Vinkenhoef
De Stuwdam,43
3815 KM Amersfoort - NETHERLANDS
Tel: +31(0) 33 45 19 505
Fax: +31(0) 33 45 19 506
info@transtecno.nl
www.transtecno.nl

**SALES OFFICE INDIA**

A/10, Anagha, S.N. Road, Mulund (W) Mumbai
400080 - INDIA
Tel: +91 9820614698
Fax-Italy: +39 051 73 49 43
indiaoffice@transtecno.com

**SALES OFFICE BRAZIL**

Rua Dr. Freire Alemão 155 / 402 - CEP. 90450-060
Auxiliadora Porto Alegre RS - BRAZIL
Tel: +55 51 3251 5447
Fax: +55 51 3251 5447
Mobile: +55 51 811 45 962
braziloffice@transtecno.com
www.transtecno.com.br

**TRANSTECNO AANDRIJFTECHNIEK B.V.**

De Stuwdam 43
3815 KM Amersfoort - NETHERLANDS
Tel: +31 (0) 33 20 4 7 006
info@transtecnoaandrijftechniek.nl
www.transtecnoaandrijftechniek.nl

**SALES OFFICE SOUTH KOREA**

D-304 Songdo BRC Smart Valley 30, Songdomirae-ro,
Yeonsu-gu, Incheon, 406-840 - KOREA
Tel: +82 70 8288 2107
Fax: +82 32 815 2107
Mobile: +82 10 5094 2107
koreaoffice@transtecno.com

**TRANSTECNO IBÉRICA****THE MODULAR GEARMOTOR, S.A.**

C/Enginy, 2 Nave 6 - 08850 Gavà (Barcelona) - SPAIN
Tel: +34 931 598 950
info@transtecno.es
www.transtecno.es

**SALES OFFICE OCEANIA**

44 Northview drive, Sunshine west 3020
Victoria - AUSTRALIA
Ph +61 03 9312 4722
Fax +61 03 9312 4714
Mobile: +61 0438060997
oceaniaoffice@transtecno.com
www.transtecno.com.au

**SALES OFFICE FRANCE**

Tel: +33 (0) 6 85 12 09 87
Fax-Italy: +39 051 73 49 43
franceoffice@transtecno.com
www.transtecno.fr



www.transtecno.com