

TRANSTECNO[®]
the modular gearmotor

The gearmotors
for farm equipment

Poultry&Pig Tecno

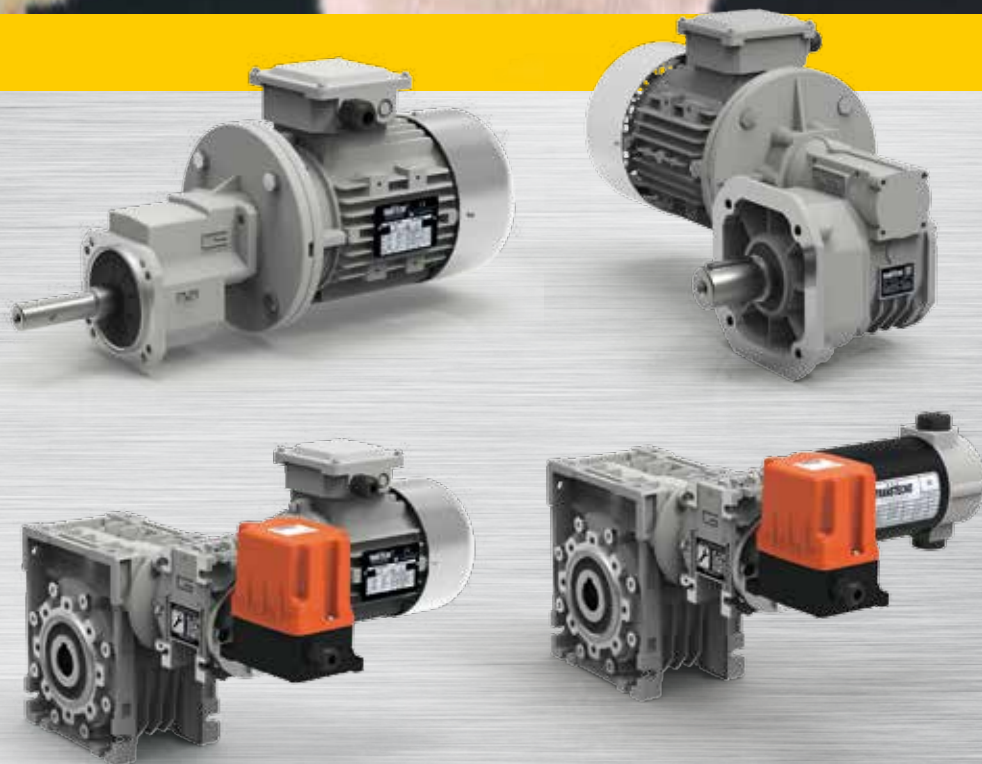

Poultry & Pig Tecno Applications

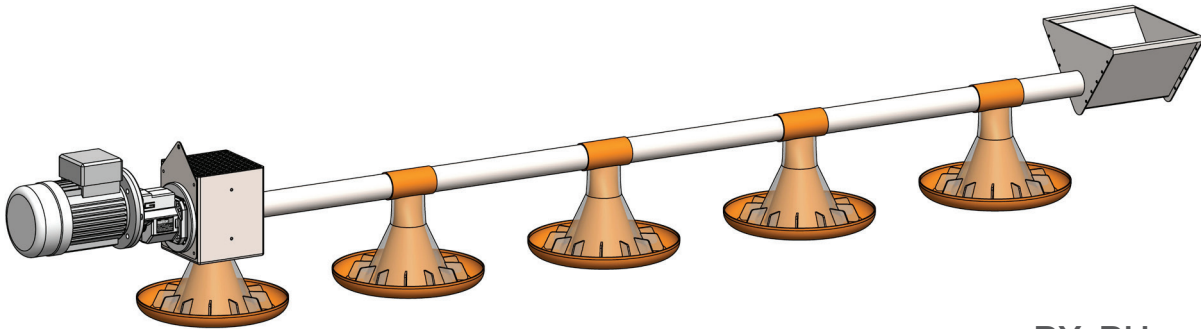

PX-PU

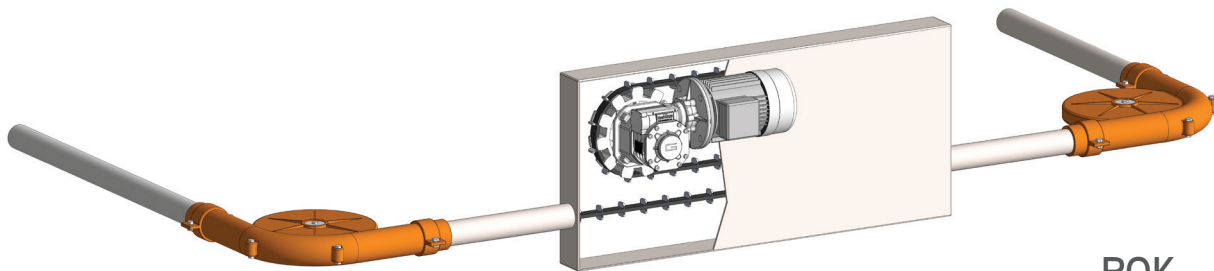
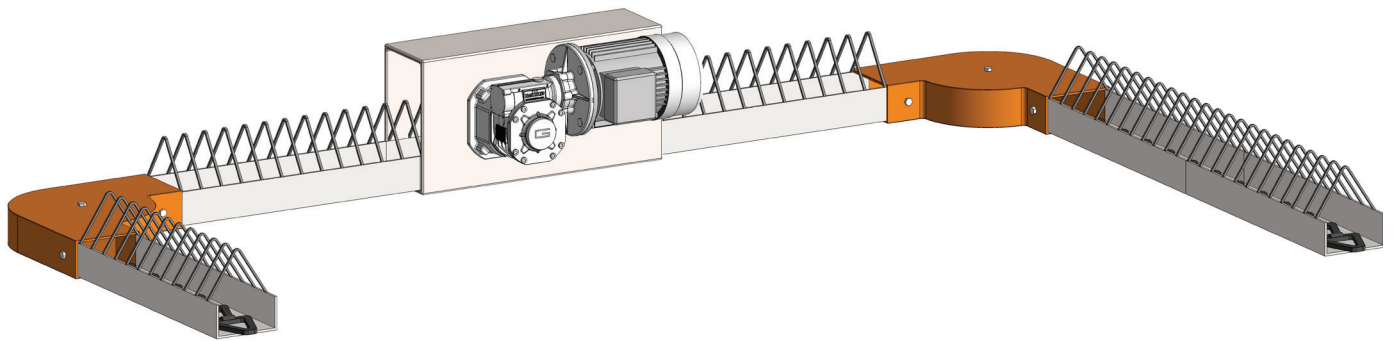
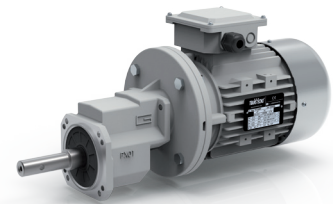

POK

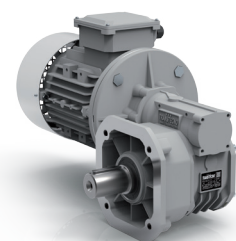

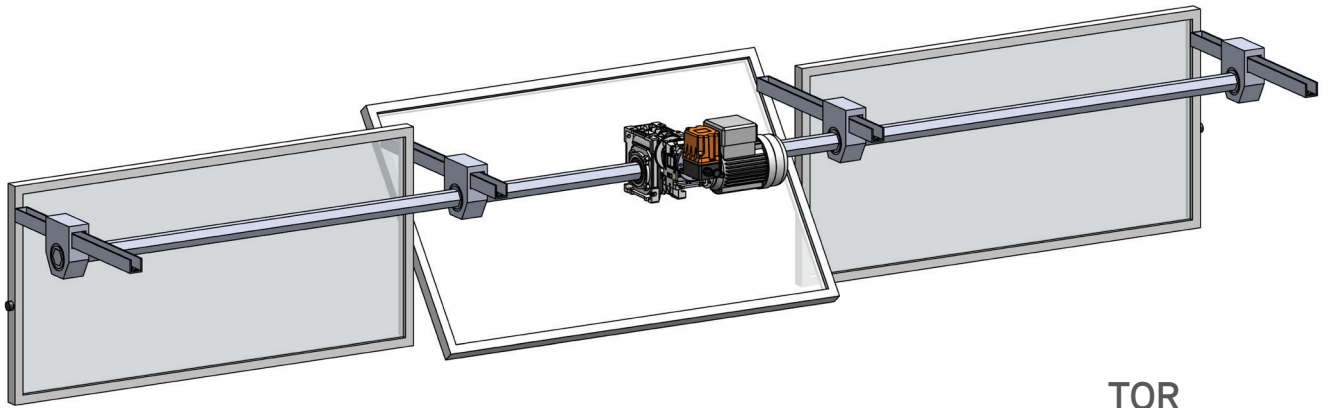

TOR

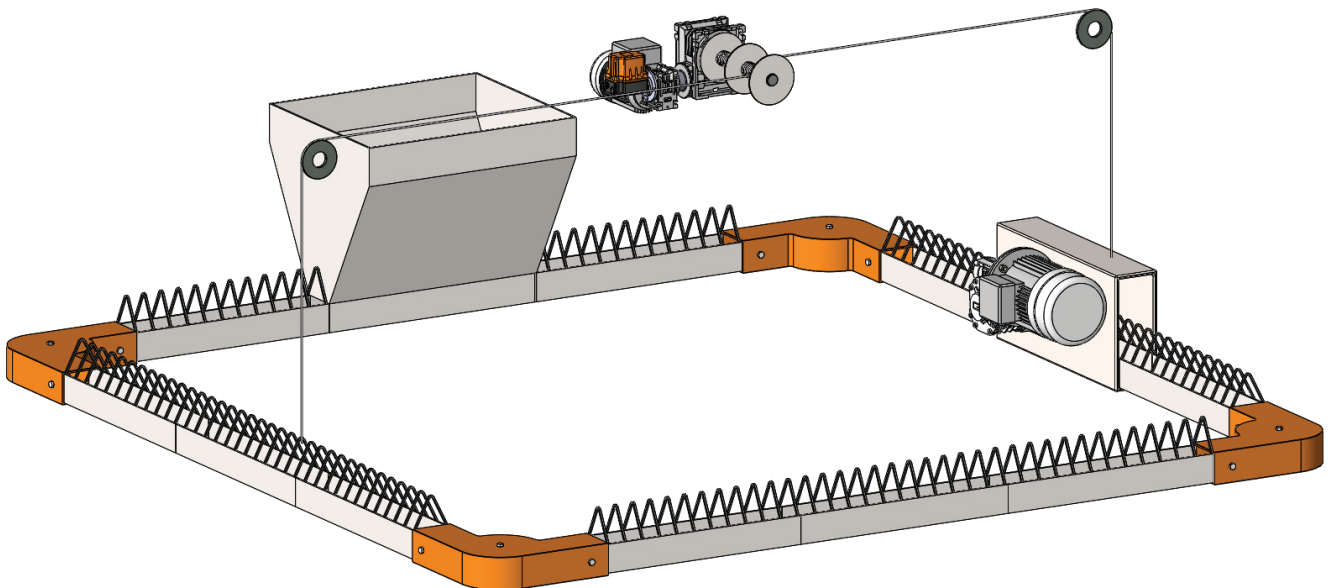
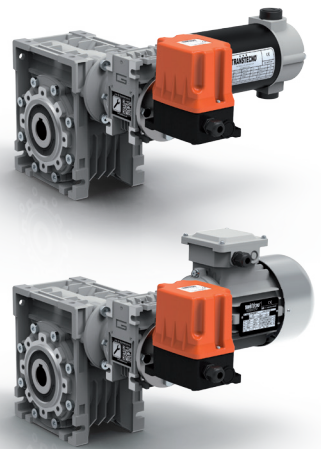
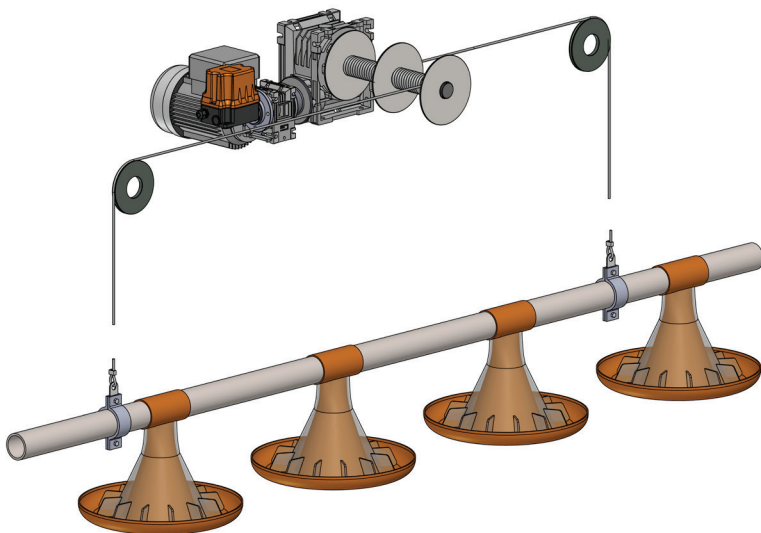

Indice	Index	Inhaltsverzeichnis	Índice	Índice	索引	Pagina Page Seite Página Pagina 页
PX-PU Motoriduttori monostadio	PX-PU <i>Single stage gearmotors</i>	PX-PU <i>Einstufige Getriebemotoren</i>	PX-PU <i>Motorreductores de etapa única</i>	PX-PU <i>Motoredutores mono estágio</i>	PX-PU 单级斜齿轮减速 电机	A1
POK Motoriduttori a vite senza fine	POK <i>Wormgearmotors</i>	POK <i>Schnecken- getriebemotoren</i>	POK <i>Motorreductores de sinfin corona</i>	POK <i>Motoredutores de rosca sem fim</i>	POK 蜗轮蜗杆减速 电机	B1
TOR Fine corsa rotativo	TOR <i>Rotary limit switch</i>	TOR <i>Dreh-Endschalter</i>	TOR <i>Final de carrera rotativo</i>	TOR <i>Fim de curso rotativo</i>	TOR 限位旋转开关	C1
Appendice	<i>Appendix</i>	<i>Appendix</i>	<i>Apêndice</i>	<i>Apêndice</i>	附录	D1

Questo catalogo annulla e sostituisce ogni precedente edizione o revisione. Ci riserviamo inoltre il diritto di apportare modifiche senza preavviso.

This catalogue supersedes any previous edition and revision. We reserve the right to implement modifications without notice.

Poultry&Pig  **Tecno**
The gearmotors for farm equipment

Motoriduttori monostadio Single stage gearmotors



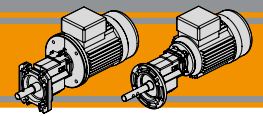

Indice	Index	Inhaltsverzeichnis	Índice	Índice	索引	Pagina Page Seite Página Pagina 页
Descrizione	<i>Description</i>	Beschreibung	<i>Descripción</i>	Descrição	介绍	A2
Designazione	<i>Classification</i>	Klassifikation	<i>Clasificación</i>	Designação	选型	A3
Lubrificazione	<i>Lubrication</i>	Schmierung	<i>Lubricación</i>	Lubrificação	润滑油	A3
Simbologia	<i>Symbols</i>	Symbole	<i>Simbología</i>	Simbologia	代号说明	A3
Dati Tecnici 50 Hz	<i>Technical data 50 Hz</i>	Technische Daten 50 Hz	<i>Datos técnicos 50 Hz</i>	Dados Tecnicos 50 Hz	技术参数 50Hz	A4
Dati Tecnici 60 Hz	<i>Technical data 60 Hz</i>	Technische Daten 60 Hz	<i>Datos técnicos 60 Hz</i>	Dados Tecnicos 60 Hz	技术参数 60Hz	A6
Motori Applicabili	<i>IEC Motor adapters</i>	IEC Motoradapter	<i>Motores aplicables</i>	Motores aplicáveis	IEC电机适配法兰	A8
Dimensioni	<i>Dimensions</i>	Abmessungen	<i>Dimensiones</i>	Dimensões	尺寸规格	A8
Note	<i>Notes</i>	Anmerkung	<i>Nota</i>	Nota	注解	A12

Questa sezione annulla e sostituisce ogni precedente edizione o revisione. Qualora questa sezione non Vi sia giunta in distribuzione controllata, l'aggiornamento dei dati ivi contenuto non è assicurato. **In tal caso la versione più aggiornata è disponibile sul nostro sito internet www.transtecno.com**

This section replaces any previous edition and revision. If you obtained this catalogue other than through controlled distribution channels, the most up to date content is not guaranteed. In this case the latest version is available on our web site www.transtecno.com

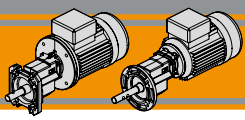

PX-PU

Motoriduttori monostadio Single stage gearmotors

Descrizione	Description	Beschreibung	Descripción	Descrição	介绍
<p>I motoriduttori PX-PU sono stati pensati per le linee di alimentazione del settore avicolo. Sono motoriduttori monostadio con carcassa in alluminio la cui prerogativa è l'economicità, lasciando comunque libero il cliente di personalizzare flange e alberi/manicotti sia in entrata che in uscita secondo le proprie esigenze.</p>	<p>The PX-PU gearmotors have been specifically designed for feeding systems in poultry farms. All gearmotors have been made up with diecast aluminum housing and single stage helical gears. A low cost solution with a high degree of customization. A wide selection of input/output flanges and shafts is available in order to satisfy each customer's specific demand.</p>	<p>Die Getriebemotoren PX-PU wurde speziell für Fütterungssysteme in Geflügelfarmen entwickelt. Alle Getriebemotoren bestehen aus einem Druckguss Aluminiumgehäuse und einstufigen Stirnrädern, also eine preisgünstige und trotzdem äußerst kundenangepasste Lösung. Eine große Auswahl an Antriebs- und Abtriebs-Flanschen und Wellen stehen für kundenspezifische Anforderungen zur Verfügung.</p>	<p>Los motorreductores PX-PU han sido pensados para las líneas de alimentación del sector avícola. Son motorreductores de etapa única con caja en aluminio, cuya dote principal es la economía, dejando al cliente la libertad de personalizar bridas y ejes/manguitos tanto en entrada como en salida, según sus propias necesidades.</p>	<p>Os motoredutores PX-PU foram pensados para as linhas de alimentação do setor avicultor. São motoredutores mono estágio, com carcaça em alumínio, e a sua prerrogativa é a sua economia, deixando o cliente livre para personalizar flanges e eixos alças, seja na entrada que na saída segundo a necessidade do cliente.</p>	<p>PX-PU 系列减速电机是针对畜牧业农场的饲养系统而设计的，所有的减速电机都是压铸铝合金箱体加一个单级斜齿轮减速电机。不但价格经济而且可按客户需求定制，满足客户高要求。可安装多种不同型号的输入输出法兰和连接轴来满足客户的特定需求。</p>

Flange d'entrata - Input flanges - Antriebsflansche - Bridas de entrada - Flange de entrada - 输入法兰
Sensi di rotazione - Direction of rotation - Drehrichtung - Sentido de rotación - Sentido de rotação - 运转方向

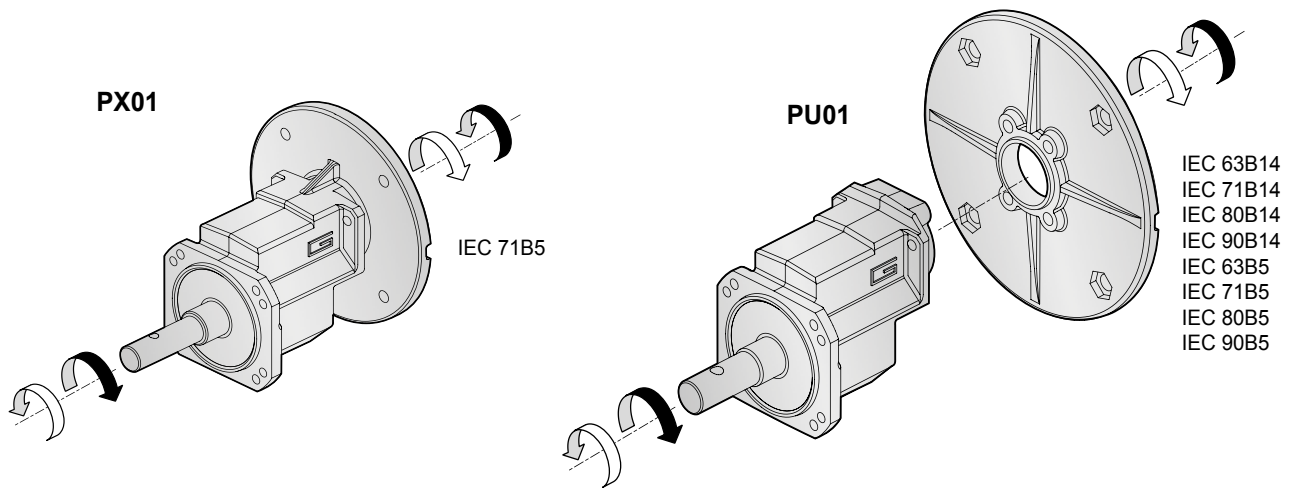

Flange d'uscita - Output flanges - Abtriebsflansche - Bridas de saída - Flange de saída - 输出法兰

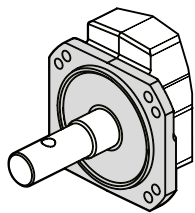

Realizzate a richiesta del cliente
Customizable upon request
 Kundenanpassung auf Anfrage
 Personalizable bajo petición del cliente
 Projetada em base à necessidade do cliente
 可按客户要求定制

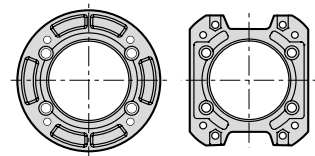

Alberi d'uscita - Output shafts - Abtriebswellen - Ejes de salida - Eixo de saída - 输出轴

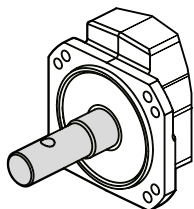

Realizzati a richiesta del cliente
Customizable upon request
 Kundenanpassung auf Anfrage
 Personalizable bajo petición del cliente
 Projetada em base à necessidade do cliente
 可按客户要求定制

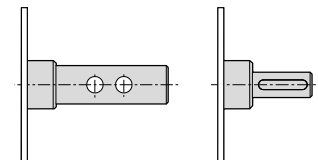

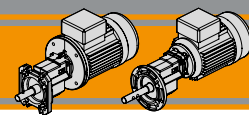

Designazione Classification Klassifikation Clasificación Designação 选型

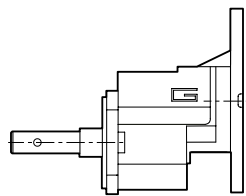

PX01 U

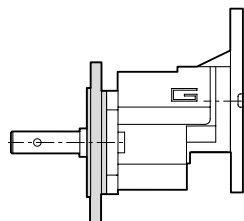

PX01 F

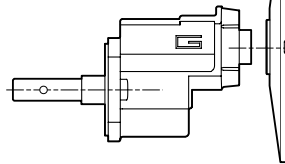

PU01 U

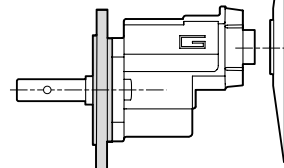

PU01 F

Riduttore / Gearbox / Getriebe / Reductor / Redutores / 减速机

PU	01	3,19	FT1	P71B5	O1
Tipo Type Tip Tipo Tipo 种类	Grandezza Size Größe Tamaño Tamanho 型号	Rapporto Ratio Übersetzung Relación de reducción Redução 速比	Versione riduttore Gearbox version Getriebeversion Versión reductor Versão reductor 置式	IEC 	Albero d'uscita Output shaft Abtriebswelle Eje de salida Eixo de saída 输出轴
PX	01	Vedi tabelle See tables Siehe Tabellen Vease tablas Ver tabela 见表格	Vedi tabelle See tables Siehe Tabellen Vease tablas Ver tabela 见表格	P71B5	Vedi tabelle See tables Siehe Tabellen Vease tablas Ver tabela 见表格
PU				P63 P90 ...	

Motore / Motor / Motor / Motor / Motor / 电机

0.37kW	4p	3ph	230/400V	50Hz	T1
Potenza Power Leistung Potencia Potência 功率	Poli Poles Pole Polos Polos 极数	Fasi Phases Phasen Fases Fases 相数	Tensione Voltage Spannung Tensión Tensão 电压	Frequenza Frequency Frequenz Frecuencia Frequência 频率	Pos. morsettiera Terminal box pos. Position Klemmenkasten Posición Caja de Bornes Posição Bloco terminal 接线盒位置
Vedi tabelle See tables Siehe Tabellen Vease tablas Ver tabela 见表格	2p 4p 6p 8p	1ph 3ph	230/400V 220/380V ... 230V ...	50Hz 60Hz	T1 (Std) T4 T3

Lubrificazione Lubrication Schmierung Lubricación Lubrificação 润滑油

I motoriduttori PX e PU sono forniti completi di lubrificante sintetico viscosità 320 e non necessitano di manutenzione. Permanent synthetic oil long-life lubrication (viscosity grade 320) on both PX and PU gearmotors. Dauerschmierung mit Long-life Synthetiköl (Viskositätsgrad 320) für Getriebemotoren PX und PU. Los motorreductores PX y PU se proporcionan completos de lubricante sintético viscosidad 320 y no necesitan mantenimiento. Os motoredutores PX e PU são fornecidos já com lubrificante sintético, com viscosidade de 320 não necessitando. PX 和PU系列减速机均使用长寿命合成润滑油(粘度320)。

	Simbologia	Symbols	Symbole	Simbología	Simbologia	代号说明
n_1 [min ⁻¹]	Velocità in ingresso	Input speed	Eingangsdrehzahl	Velocidad de entrada	Velocidade de entrada	输入转速
n_2 [min ⁻¹]	Velocità in uscita	Output speed	Ausgangsdrehzahl	Velocidad de salida	Velocidade de saída	输出转速
i	Rapporto di riduzione	Ratio	Übersetzung	Relación de reducción	Relação de redução	速比
P_1 [kW]	Potenza in ingresso	Input power	Eingangsleistung	Potencia en entrada	Potência de entrada	输入功率
M_2 [Nm]	Coppia nominale	Nominal torque	Nennmoment	Par nominal	Torque	额定扭矩
sf	Fattore di servizio	Service factor	Servicefaktor	Factor de servicio	Fator de serviço	使用系数

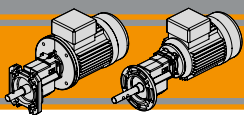

[IEC - 50 Hz - n₁ 1400 min⁻¹]

P ₁ [kW]	n ₂ [min ⁻¹]	M ₂ [Nm]	sf	i		
------------------------	--	------------------------	----	---	---	---

P ₁ [kW]	n ₂ [min ⁻¹]	M ₂ [Nm]	sf	i		
------------------------	--	------------------------	----	---	---	---

0.12

63A4 (1400 min ⁻¹)	888	1.3	32	1.58	PU01	B5/B14
	732	1.5	26	1.91		B5/B14
	596	1.9	21	2.35		B5/B14
	560	2.0	20	2.50		B5/B14
	467	2.4	21	3.00		B5/B14
	439	2.5	20	3.19		B5/B14
	370	3.0	17	3.79		B5/B14
	356	3.1	16	3.93		B5/B14
	295	3.8	13	4.75		B5/B14
	275	4.0	12	5.09		B5/B14
	246	4.5	11	5.70		B5/B14
	190	5.9	6.8	7.38		B5/B14
	178	6.3	6.4	7.88		B5/B14
	163	6.8	5.9	8.57		B5/B14
	145	7.7	4.6	9.67		B5/B14

0.25

71A4 (1400 min ⁻¹)	888	2.6	15.3	1.58	PX-PU01	B5/B14
	732	3.2	12.6	1.91		B5/B14
	596	3.9	10.3	2.35		B5/B14
	560	4.1	9.7	2.50		B5/B14
	467	5.0	10.1	3.00		B5/B14
	439	5.3	9.5	3.19		B5/B14
	370	6.3	8.0	3.79		B5/B14
	356	6.5	7.7	3.93		B5/B14
	295	7.9	6.4	4.75		B5/B14
	275	8.4	5.9	5.09		B5/B14
	246	9.4	5.3	5.70		B5/B14
	190	12	3.3	7.38		B5/B14
	178	13	3.1	7.88		B5/B14
	163	14	2.8	8.57		B5/B14
	145	16	2.2	9.67		B5/B14

0.18

63B4 (1400 min ⁻¹)	888	1.9	21	1.58	PU01	B5/B14
	732	2.3	18	1.91		B5/B14
	596	2.8	14	2.35		B5/B14
	560	3.0	13	2.50		B5/B14
	467	3.6	14	3.00		B5/B14
	439	3.8	13	3.19		B5/B14
	370	4.5	11	3.79		B5/B14
	356	4.7	11	3.93		B5/B14
	295	5.7	8.8	4.75		B5/B14
	275	6.1	8.2	5.09		B5/B14
	246	6.8	7.4	5.70		B5/B14
	190	8.8	4.6	7.38		B5/B14
	178	9.4	4.3	7.88		B5/B14
	163	10	3.9	8.57		B5/B14
	145	12	3.0	9.67		B5/B14

0.37

71B4 (1400 min ⁻¹)	888	3.9	10.4	1.58	PX-PU01	B5/B14
	732	4.7	8.5	1.91		B5/B14
	596	5.8	7.0	2.35		B5/B14
	560	6.1	6.5	2.50		B5/B14
	467	7.3	6.8	3.00		B5/B14
	439	7.8	6.4	3.19		B5/B14
	370	9.3	5.4	3.79		B5/B14
	356	10	5.2	3.93		B5/B14
	295	12	4.3	4.75		B5/B14
	275	12	4.0	5.09		B5/B14
	246	14	3.6	5.70		B5/B14
	190	18	2.2	7.38		B5/B14
	178	19	2.1	7.88		B5/B14
	163	21	1.9	8.57		B5/B14
	145	24	1.5	9.67		B5/B14

0.22

63C4 (1400 min ⁻¹)	888	2.3	17	1.58	PU01	B5/B14
	732	2.8	14	1.91		B5/B14
	596	3.4	12	2.35		B5/B14
	560	3.6	11	2.50		B5/B14
	467	4.4	11	3.00		B5/B14
	439	4.6	11	3.19		B5/B14
	370	5.5	9.1	3.79		B5/B14
	356	5.7	8.7	3.93		B5/B14
	295	6.9	7.2	4.75		B5/B14
	275	7.4	6.7	5.09		B5/B14
	246	8.3	6.0	5.70		B5/B14
	190	10.7	3.7	7.38		B5/B14
	178	11.5	3.5	7.88		B5/B14
	163	12.5	3.2	8.57		B5/B14
	145	14.1	2.5	9.67		B5/B14

0.55

71C4 (1400 min ⁻¹)	888	5.7	7.0	1.58	PX-PU01	B5/B14
	732	7.0	5.7	1.91		B5/B14
	596	8.6	4.7	2.35		B5/B14
	560	9.1	4.4	2.50		B5/B14
	467	11	4.6	3.00		B5/B14
	439	12	4.3	3.19		B5/B14
	370	14	3.6	3.79		B5/B14
	356	14	3.5	3.93		B5/B14
	295	17	2.9	4.75		B5/B14
	275	19	2.7	5.09		B5/B14
	246	21	2.4	5.70		B5/B14
	190	27	1.5	7.38		B5/B14
	178	29	1.4	7.88		B5/B14
	163	31	1.3	8.57		B5/B14
	145	35	1.0	9.67		B5/B14

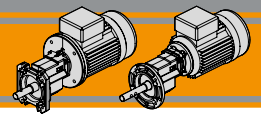

[IEC - 50 Hz - n₁ 1400 min⁻¹]

P ₁ [kW]	n ₂ [min ⁻¹]	M ₂ [Nm]	sf	i		
------------------------	--	------------------------	----	---	---	---

P ₁ [kW]	n ₂ [min ⁻¹]	M ₂ [Nm]	sf	i		
------------------------	--	------------------------	----	---	---	---

0.55

80A4 (1400 min ⁻¹)	888	5.7	7.0	1.58	PU01	B5/B14
	732	7.0	5.7	1.91		B5/B14
	596	8.6	4.7	2.35		B5/B14
	560	9.1	4.4	2.50		B5/B14
	467	11	4.6	3.00		B5/B14
	439	12	4.3	3.19		B5/B14
	370	14	3.6	3.79		B5/B14
	356	14	3.5	3.93		B5/B14
	295	17	2.9	4.75		B5/B14
	275	19	2.7	5.09		B5/B14
	246	21	2.4	5.70		B5/B14
	190	27	1.5	7.38		B5/B14
	178	29	1.4	7.88		B5/B14
	163	31	1.3	8.57		B5/B14
	145	35	1.0	9.67		B5/B14

1.1

80C4 90S4 (1400 min ⁻¹)	888	11	3.5	1.58	PU01	B5/B14
	732	14	2.9	1.91		B5/B14
	596	17	2.3	2.35		B5/B14
	560	18	2.2	2.50		B5/B14
	467	22	2.3	3.00		B5/B14
	439	23	2.2	3.19		B5/B14
	370	28	1.8	3.79		B5/B14
	356	29	1.7	3.93		B5/B14
	295	35	1.4	4.75		B5/B14
	275	37	1.3	5.09		B5/B14
	246	41	1.2	5.70		B5/B14

1.5

90B4 (1400 min ⁻¹)	888	16	2.6	1.58	PU01	B5/B14
	732	19	2.1	1.91		B5/B14
	596	23	1.7	2.35		B5/B14
	560	25	1.6	2.50		B5/B14
	467	30	1.7	3.00		B5/B14
	439	32	1.6	3.19		B5/B14
	370	37	1.3	3.79		B5/B14
	356	39	1.3	3.93		B5/B14
	295	47	1.1	4.75		B5/B14
	275	50	1.0	5.09		B5/B14

0.75

71D4 (1400 min ⁻¹)	888	7.8	5.1	1.58	PX-PU01	B5/B14
	732	9.5	4.2	1.91		B5/B14
	596	12	3.4	2.35		B5/B14
	560	12	3.2	2.50		B5/B14
	467	15	3.4	3.00		B5/B14
	439	16	3.2	3.19		B5/B14
	370	19	2.7	3.79		B5/B14
	356	19	2.6	3.93		B5/B14
	295	24	2.1	4.75		B5/B14
	275	25	2.0	5.09		B5/B14
	246	28	1.8	5.70		B5/B14
	190	37	1.1	7.38		B5/B14
	178	39	1.0	7.88		B5/B14

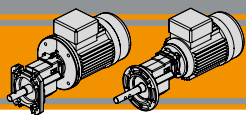

0.75

80B4 (1400 min ⁻¹)	888	7.8	5.1	1.58	PU01	B5/B14
	732	9.5	4.2	1.91		B5/B14
	596	12	3.4	2.35		B5/B14
	560	12	3.2	2.50		B5/B14
	467	15	3.4	3.00		B5/B14
	439	16	3.2	3.19		B5/B14
	370	19	2.7	3.79		B5/B14
	356	19	2.6	3.93		B5/B14
	295	24	2.1	4.75		B5/B14
	275	25	2.0	5.09		B5/B14
	246	28	1.8	5.70		B5/B14
	190	37	1.1	7.38		B5/B14
	178	39	1.0	7.88		B5/B14



[IEC - 60 Hz - n_1 1750 min⁻¹]

P ₁ [kW]	n ₂ [min ⁻¹]	M ₂ [Nm]	sf	i		
------------------------	--	------------------------	----	---	---	---

P ₁ [kW]	n ₂ [min ⁻¹]	M ₂ [Nm]	sf	i		
------------------------	--	------------------------	----	---	---	---

0.12

63A4 (1750 min ⁻¹)	1110	1.0	37	1.58	PU01	B5/B14
	915	1.2	31	1.91		B5/B14
	745	1.5	25	2.35		B5/B14
	700	1.6	23	2.50		B5/B14
	583	1.9	24	3.00		B5/B14
	549	2.0	23	3.19		B5/B14
	462	2.4	19	3.79		B5/B14
	445	2.5	19	3.93		B5/B14
	368	3.0	15	4.75		B5/B14
	344	3.2	14	5.09		B5/B14
	307	3.6	13	5.70		B5/B14
	237	4.7	7.9	7.38		B5/B14
	222	5.0	7.4	7.88		B5/B14
	204	5.4	6.8	8.57		B5/B14
181	6.1	5.3	9.67	B5/B14		

0.25

71A4 (1750 min ⁻¹)	1110	2.1	18	1.58	PX-PU01	B5/B14
	915	2.5	15	1.91		B5/B14
	745	3.1	12	2.35		B5/B14
	700	3.3	11	2.50		B5/B14
	583	4.0	12	3.00		B5/B14
	549	4.2	11	3.19		B5/B14
	462	5.0	9.3	3.79		B5/B14
	445	5.2	8.9	3.93		B5/B14
	368	6.3	7.4	4.75		B5/B14
	344	6.7	6.9	5.09		B5/B14
	307	7.5	6.2	5.70		B5/B14
	237	10	3.8	7.38		B5/B14
	222	10	3.6	7.88		B5/B14
	204	11	3.3	8.57		B5/B14
181	13	2.5	9.67	B5/B14		

0.18

63B4 (1750 min ⁻¹)	1110	1.5	25	1.58	PU01	B5/B14
	915	1.8	20	1.91		B5/B14
	745	2.2	17	2.35		B5/B14
	700	2.4	16	2.50		B5/B14
	583	2.9	16	3.00		B5/B14
	549	3.0	15	3.19		B5/B14
	462	3.6	13	3.79		B5/B14
	445	3.7	12	3.93		B5/B14
	368	4.5	10	4.75		B5/B14
	344	4.9	9.6	5.09		B5/B14
	307	5.4	8.6	5.70		B5/B14
	237	7.0	5.3	7.38		B5/B14
	222	7.5	5.0	7.88		B5/B14
	204	8.2	4.6	8.57		B5/B14
181	9.2	3.5	9.67	B5/B14		

0.37

71B4 (1750 min ⁻¹)	1110	3.1	12	1.58	PX-PU01	B5/B14
	915	3.7	9.9	1.91		B5/B14
	745	4.6	8.1	2.35		B5/B14
	700	4.9	7.6	2.50		B5/B14
	583	5.9	7.9	3.00		B5/B14
	549	6.2	7.4	3.19		B5/B14
	462	7.4	6.3	3.79		B5/B14
	445	7.7	6.0	3.93		B5/B14
	368	9.3	5.0	4.75		B5/B14
	344	10	4.7	5.09		B5/B14
	307	11	4.2	5.70		B5/B14
	237	14	2.6	7.38		B5/B14
	222	15	2.4	7.88		B5/B14
	204	17	2.2	8.57		B5/B14
181	19	1.7	9.67	B5/B14		

0.22



63C4 (1750 min ⁻¹)	1110	1.8	20	1.58	PU01	B5/B14
	915	2.2	17	1.91		B5/B14
	745	2.7	14	2.35		B5/B14
	700	2.9	13	2.50		B5/B14
	583	3.5	13	3.00		B5/B14
	549	3.7	12	3.19		B5/B14
	462	4.4	10	3.79		B5/B14
	445	4.6	10	3.93		B5/B14
	368	5.5	8.4	4.75		B5/B14
	344	5.9	7.8	5.09		B5/B14
	307	6.6	7.0	5.70		B5/B14
	237	8.6	4.3	7.38		B5/B14
	222	9.2	4.1	7.88		B5/B14
	204	10.0	3.7	8.57		B5/B14
181	11.3	2.9	9.67	B5/B14		

0.55

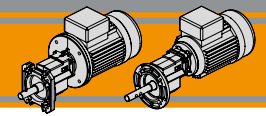
71C4 (1750 min ⁻¹)	1110	4.6	8.1	1.58	PX-PU01	B5/B14
	915	5.6	6.7	1.91		B5/B14
	745	6.8	5.4	2.35		B5/B14
	700	7.3	5.1	2.50		B5/B14
	583	8.7	5.3	3.00		B5/B14
	549	9.3	5.0	3.19		B5/B14
	462	11	4.2	3.79		B5/B14
	445	11	4.1	3.93		B5/B14
	368	14	3.4	4.75		B5/B14
	344	15	3.1	5.09		B5/B14
	307	17	2.8	5.70		B5/B14
	237	21	1.7	7.38		B5/B14
	222	23	1.6	7.88		B5/B14
	204	25	1.5	8.57		B5/B14
181	28	1.2	9.67	B5/B14		



[IEC - 60 Hz - n_1 1750 min⁻¹]

P ₁ [kW]	n ₂ [min ⁻¹]	M ₂ [Nm]	sf	i		
------------------------	--	------------------------	----	---	---	---

P ₁ [kW]	n ₂ [min ⁻¹]	M ₂ [Nm]	sf	i		
------------------------	--	------------------------	----	---	---	---

0.55

80A4 (1750 min ⁻¹)	1110	4.6	8.1	1.58	PU01	B5/B14
	915	5.6	6.7	1.91		B5/B14
	745	6.8	5.4	2.35		B5/B14
	700	7.3	5.1	2.50		B5/B14
	583	8.7	5.3	3.00		B5/B14
	549	9.3	5.0	3.19		B5/B14
	462	11	4.2	3.79		B5/B14
	445	11	4.1	3.93		B5/B14
	368	14	3.4	4.75		B5/B14
	344	15	3.1	5.09		B5/B14
	307	17	2.8	5.70		B5/B14
	237	21	1.7	7.38		B5/B14
	222	23	1.6	7.88		B5/B14
	204	25	1.5	8.57		B5/B14
	181	28	1.2	9.67		B5/B14

1.1

80C4 90S4 (1750 min ⁻¹)	1110	9.2	4.1	1.58	PU01	B5/B14
	915	11	3.3	1.91		B5/B14
	745	14	2.7	2.35		B5/B14
	700	15	2.6	2.50		B5/B14
	583	17	2.7	3.00		B5/B14
	549	19	2.5	3.19		B5/B14
	462	22	2.1	3.79		B5/B14
	445	23	2.0	3.93		B5/B14
	368	28	1.7	4.75		B5/B14
	344	30	1.6	5.09		B5/B14
	307	33	1.4	5.70		B5/B14

0.75

71D4 (1750 min ⁻¹)	1110	6.3	5.9	1.58	PX-PU01	B5/B14
	915	7.6	4.9	1.91		B5/B14
	745	9.3	4.0	2.35		B5/B14
	700	10	3.7	2.50		B5/B14
	583	12	3.9	3.00		B5/B14
	549	13	3.7	3.19		B5/B14
	462	15	3.1	3.79		B5/B14
	445	16	3.0	3.93		B5/B14
	368	19	2.5	4.75		B5/B14
	344	20	2.3	5.09		B5/B14
	307	23	2.1	5.70		B5/B14
	237	29	1.3	7.38		B5/B14
	222	31	1.2	7.88		B5/B14
	204	34	1.1	8.57		B5/B14

1.5

90B4 (1750 min ⁻¹)	1110	13	3.0	1.58	PU01	B5/B14
	915	15	2.4	1.91		B5/B14
	745	19	2.0	2.35		B5/B14
	700	20	1.9	2.50		B5/B14
	583	24	2.0	3.00		B5/B14
	549	25	1.8	3.19		B5/B14
	462	30	1.5	3.79		B5/B14
	445	31	1.5	3.93		B5/B14
	368	38	1.2	4.75		B5/B14
	344	40	1.2	5.09		B5/B14
	307	45	1.0	5.70		B5/B14

0.75

80B4 (1750 min ⁻¹)	1110	6.3	5.9	1.58	PU01	B5/B14
	915	7.6	4.9	1.91		B5/B14
	745	9.3	4.0	2.35		B5/B14
	700	10	3.7	2.50		B5/B14
	583	12	3.9	3.00		B5/B14
	549	13	3.7	3.19		B5/B14
	462	15	3.1	3.79		B5/B14
	445	16	3.0	3.93		B5/B14
	368	19	2.5	4.75		B5/B14
	344	20	2.3	5.09		B5/B14
	307	23	2.1	5.70		B5/B14
	237	29	1.3	7.38		B5/B14
	222	31	1.2	7.88		B5/B14
	204	34	1.1	8.57		B5/B14

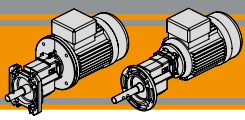

PX-PU

Motoriduttori monostadio Single stage gearmotors

Motori applicabili IEC Motor adapters IEC Motoradapter Motores Aplicables Motores aplicáveis IEC电机适配法兰

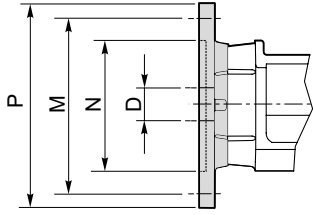

	IEC	N	M	P	D	i												
						1.58	1.91	2.35	2.50	3.00	3.19	3.79	3.93	4.75	5.09	5.70	7.38	7.88
PX	71B5	110	130	160	14													
PU	90B5	130	165	200	24													
	90B14	95	115	140	24													
	80B5	130	165	200	19													
	80B14	80	100	120	19													
	71B5	110	130	160	14													
	71B14	70	85	105	14													
	63B5	140	115	95	11													
	63B14	90	75	90	11													
						B												

N.B. Le aree in grigio indicano l'applicabilità delle corrispondenti grandezze motore;
N.B. Grey areas indicate motor inputs available on each size of unit;
N.B. In den grauen Bereichen sind die Motorbaugrößen für jede Getriebeversion angegeben;
N.B. Las áreas en gris indican la disponibilidad del correspondiente tamaño del motor;
Obs. As áreas em cinza indicam a aplicabilidade dos correspondentes tamanhos de motores;
 注解: 灰色部分表示该输入法兰可选。

B = Boccia di riduzione in acciaio;
B = Metal shaft sleeve;
B = Metal-Wellenhülse;
B = casquillo de reducción en acero;
B = Bucha de redução em aço;
B = 金属轴套

Dimensioni Dimensions Abmessungen Dimensiones Dimensões 尺寸规格

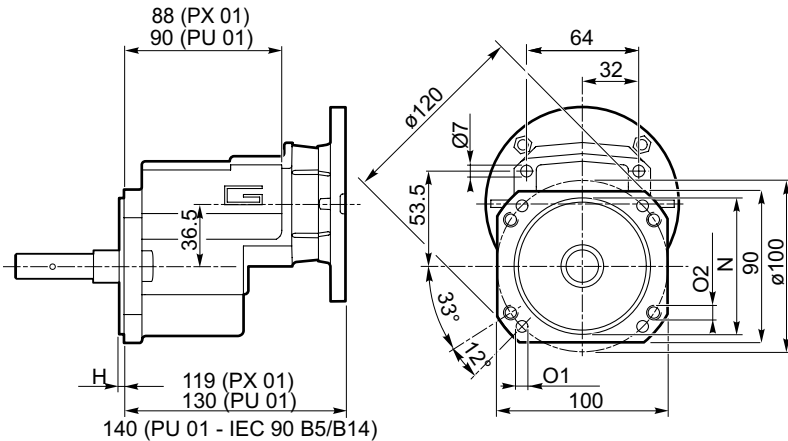

Versione riduttore Gearbox version Getriebeversion Versión reductor versao redutor 产品型号	N h7	H	O1	O2	
PX01 PU01	U	80	3.5	Ø7 - n°4	M8 - n°4
	U1	85	3.5	M8 - n°4	Ø7 - n°4
	U2	80	3.5	M8 - n°4	M8 - n°4
	U3	80	3.5	Ø9 - n°4	Ø7 - n°4
	U4	\	\	M8 - n°4	Ø7 - n°4

Kg 2.4 - 2.8

Nota: Per la scelta delle flange e degli alberi in uscita preghiamo di riferirsi alle pagine seguenti. Se non sono presenti i componenti desiderati ricordiamo che è possibile personalizzarli secondo le Vostre specifiche.
Note: Please see the following pages for the output shafts and flanges available. If you can't find the right components, we can customize them on request.
Anmerkung: Auf folgenden Seiten sehen Sie erhältliche Abtriebswellen und -flansche. Wenn Sie keine richtige Variante finden, können wir individuelle Kundenanpassung anbieten.
Nota: Para elegir bridas y ejes de salida rogamos hagan referencia a las páginas siguientes. Si los componentes que desean no están presentes, recordamos que es posible personalizarlos según sus necesidades.
Nota: Para a escolha das flanges e dos eixos de saída pedimos de observar as próximas páginas. Se os componentes necessários não se fazem presentes, lembramos que é possível personalizar-los de acordo com as vossas especificações.
 注解: 适配的输出轴和输出法兰请见下一页, 如果从中找不到适合的部件, 我们可按客户要求定制。

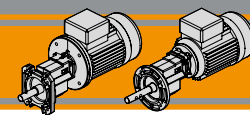

Dimensioni

Dimensions

Abmessungen

Dimensiones

Dimensões

尺寸规格

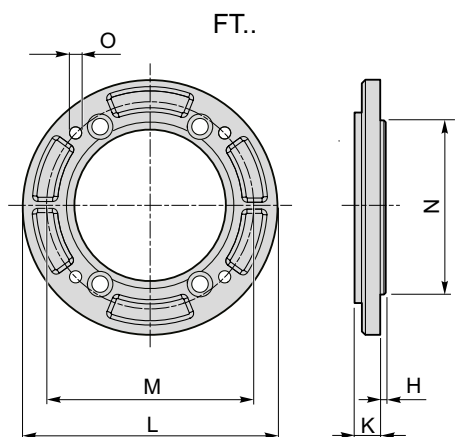

Dimensioni Dimensions Abmessungen Dimensiones Dimensões 尺寸规格		L	M	N f7	O	K	H	Kg
PX01 PU01	FT1	140	115	95	M8	14	3	0.27
	FT5	140	115	/	M8	14	/	0.27
	FT2	160	130	110	9	14	3.5	0.38
	FT4	160	130	/	9	14	/	0.38
	FT3	200	165	130	11	14	3.5	0.58
	FT9	200	165	/	11	14	/	0.58

PX-PU

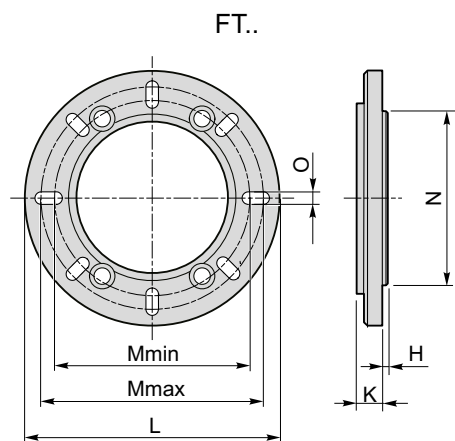

Dimensioni Dimensions Abmessungen Dimensiones Dimensões 尺寸规格		L	M	N f7	O	K	H	Kg
PX01 PU01	FT7	140	115-130	95	8.5	18	3	0.32
	FT6	145	115-130	95	8.5	18	3	0.34
	FT10	140	115-130	/	8.5	18	/	0.32

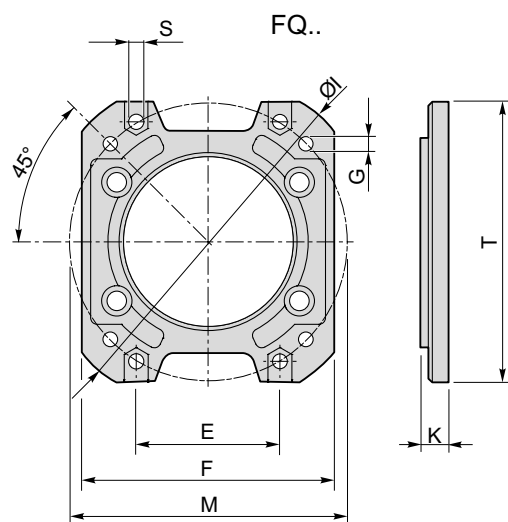

Dimensioni Dimensions Abmessungen Dimensiones Dimensões 尺寸规格		F	T	M	G	E	R	S	I	K	Kg
PX01 PU01	FQ1	116	129	127	M8	66	110	7	154	18	0.28
	FQ4	150	150	165	11	/	/	/	200	14	0.40
	FQ5	116	129	127	5/16" UNC	66	110	7	154	18	0.28

Preferenziali - Preferred - Vorzugsabtriebswellen - Preferencial - Preferencial - 首选

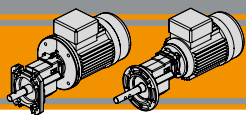

PX-PU

Motoriduttori monostadio Single stage gearmotors

Dimensioni

Dimensions

Abmessungen

Dimensiones

Dimensões

尺寸规格

Alberi d'uscita / Output shafts / Abtriebswellen / Ejes de salida / Eixo de saída / 输出轴

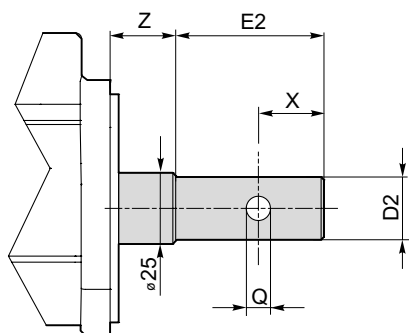

Dimensioni Dimensions Abmessungen Dimensiones Dimensões 尺寸规格	D2	E2	X	Z	Q
O53	15.85	58	19	21.8	6.35
O69	15.88	60	19.05	5.5	6.35
O16	16	50	21	18	7
O17	16	50	21	19	6.5
O32	16	40	10	14	6.4
O68	16	50	21	18	8
O80	16	77	52.5	23	7
O54	17	48	18	20	6
O55	17	48	18	20	8
O4	19	60	23	23	6.5
O5	19	44.1	13.5	9.9	6.5
O6	19	82	30	30.5	8.5
O10	19	80	21.5	17	8.5
O13	19	100	50	9.9	6.5
O23	19	58	24	18	8
O34	19	40	13	0	6.5
O41	19	100	50	9.9	M8
O46	19	60	23	23	8
O48	19	100	50	9.9	8
O57	19	57	23	18	6.5
O61	19	40	14	21	6.5
O72	19	58	19	21.8	6.35
O33	19.7	100	50	4.5	6
O8	20	103	50	20	7
O9	20	84	30	13	6
O26	20	40	9	14	8.5
O30	20	50	25	17.5	6
O67	20	100	50	18	6.5
O71	20	70	20	18	6.5
O73	20	58	19	21.8	6.35
O14	21	52	23	9	6
O20	21	50	25	17.5	6
O58	21	47.8	15	18	6
O59	21	50	17	18	9
O66	21	62	28	14	6
O1	22	52	23	23	8.5
O18	22	57	23	18	8.5
O45	22	60	24	19	8.5
O79	22	35	15	0	8
...

PX01 U/F
PU01 U/F

Note: Alberi non in tabella eseguibili a richiesta. La quota Z si riferisce alla versioni U e U1. Se si sceglie la versione con flangia d'uscita la quota Z si riduce della quota K indicata nella pagina 9.

Note: Output shafts not shown in the table are available on request. Dimension Z refers to U and U1 versions. For the output flange version, dimension Z must be reduced from dimension K shown on page 9.

Anmerkung: Die Abtriebswellen, die in der Tabelle nicht vorhanden sind, können auf Anfrage angeboten werden. Die Abmessung Z für die Versionen U und U1. Für die Version mit Abtriebsflansch, muss die Abmessung Z um den Maß K, auf der Seite 9 gezeigt, reduziert werden.

Nota: los ejes no presentes en la tabla son realizables bajo petición. La medida Z se refiere a la versión U y U1. Si selecciona la versión con brida de salida, la medida Z se reduce de la medida K indicada en la página 9.

Nota: Os eixos não relacionados são disponibilizados mediante a solicitação especial. O campo Z se refere a versão U e U1. Caso seja escolhida a versão com flange de saída o campo Z se reduz ao campo K, veja a página 9.

注解: 输出轴可按客户要求定制; 尺寸Z仅适用于U和U1置式; 如所选型号带输出法兰, 尺寸Z需减去输出法兰厚度K (尺寸K见第9页)。

Preferenziali - Preferred - Vorzugsabtriebswellen - Preferencial - Preferencial - 首选

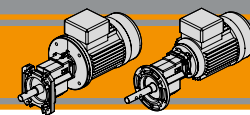

Alberi d'uscita / Output shafts / Abtriebswellen / Ejes de salida / Eixo de saída / 输出轴

PX-PU

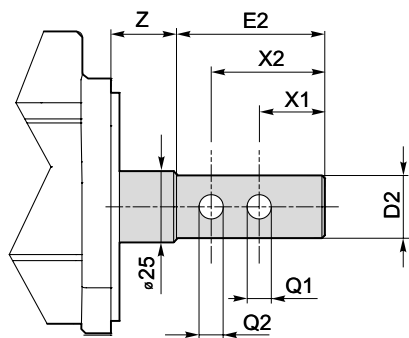

Dimensioni Dimensions Abmessungen Dimensiones Dimensões 尺寸规格	D2	E2	X1	X2	Z	Q1	Q2	
PX01 U/F	O44	16	65	23.25	38.25	28	6.5	6.5
	O15	19	92	30	48	20.5	8.5	8.5
	O27	19	100	44	59	12.5	6.5	6.5
	O40	19	92	30	48	15.5	8.5	8.5
	O62	19	60	30	46	23	6.6	6.5
	O75	19	100	44	59	12.5	6.5	6.5
	O12	19.7	100	30	50	4.5	6	6
	O31	19.7	90	30	50	13.5	6.5	6.5
	O38	19.7	100	30	50	4.5	6	6
PU01 U/F	O29	20	60	20	35	4.5	5.5	5.5
	O37	20	70	20	40	18	8	6
	O39	20	58	23	38	18	8.5	8.5
	O47	20	76	22	32	22	6.8	6.8
	O64	20.2	78.2	36.3	52.8	20	7	7
	O56	20.3	74.7	36.6	52.5	25.9	5.6	5.6
	O35	20.5	65	12	42	14	5-16" 18 UNC-2B	5-16" 18 UNC-2B
	O60	22	58	23	38	18	8.5	8.5
	O52	23	44	9	35	30	M6	M6

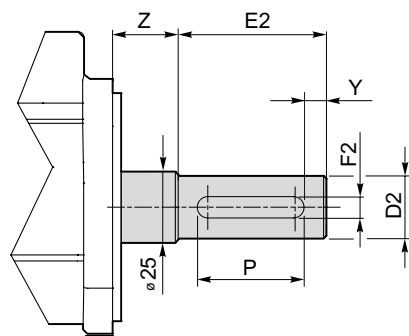

Dimensioni Dimensions Abmessungen Dimensiones Dimensões 尺寸规格	D2	E2	Y	F2	P	Z	
PX01 U/F	O2	14	30	2.5	5	25	14
	O50	14	30	2.5	5	25	0
	O3	19	40	3	6	30	0
	O22	19	40	3	6	30	18
	O43	19	40	3	6	30	5
PU01 U/F	O78	19.05	54.1	0	4.76	40.5	28.4
	O77	19.05	54.1	0	4.76	40.5	9.4
	O24	20	40	3	6	30	18
	O25	20	40	3	6	30	14
	O19	20	40	5	6	30	14
	O70	24	48	5	8	40	2

Note: Alberi non in tabella eseguibili a richiesta. La quota Z si riferisce alla versioni U e U1. Se si sceglie la versione con flangia d'uscita la quota Z si riduce della quota K indicata nella pagina 9.

Note: Output shafts not shown in the table are available on request. Dimension Z refers to U and U1 versions. For the output flange version, dimension Z must be reduced from dimension K shown on page 9.

Anmerkung: Die Abtriebswellen, die in der Tabelle nicht vorhanden sind, können auf Anfrage angeboten werden. Die Abmessung Z für die Versionen U und U1. Für die Version mit Abtriebsflansch, muss die Abmessung Z um den Maß K, auf der Seite 9 gezeigt, reduziert werden.

Nota: los ejes no presentes en la tabla son realizables bajo petición. La medida Z se refiere a la versión U y U1. Si selecciona la versión con brida de salida, la medida Z se reduce de la medida K indicada en la página 9.

Nota: Os eixos não relacionados são disponibilizados mediante a solicitação especial. O campo Z se refere a versão U e U1. Caso seja escolhida a versão com flange de saída o campo Z se reduz ao campo K, veja a página 9.

注解: 输出轴可按客户要求定制; 尺寸Z仅适用于U和U1置式; 如所选型号带输出法兰, 尺寸Z需减去输出法兰厚度K(尺寸K见第9页)。

Poultry&Pig  **Tecno**
The gearmotors for farm equipment

Motoriduttori a vite senza fine
Wormgearmotors

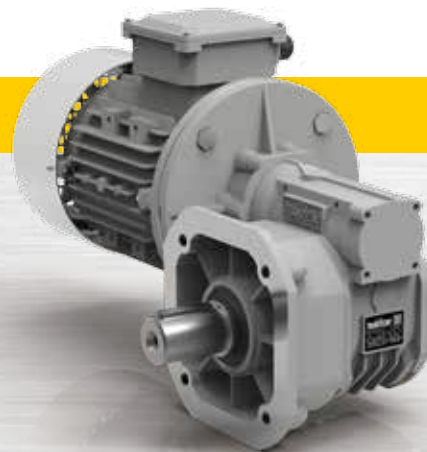

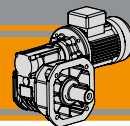

Indice	Index	Inhaltsverzeichnis	Índice	Índice	索引	Pagina Page Seite Página Pagina 页
Descrizione	<i>Description</i>	Beschreibung	<i>Descripción</i>	Descrição	介绍	B2
Designazione	<i>Classification</i>	Klassifikation	<i>Clasificación</i>	Designação	选型	B3
Simbologia	<i>Symbols</i>	Symbole	<i>Simbología</i>	Simbologia	代号说明	B4
Lubrificazione	<i>Lubrication</i>	Schmierung	<i>Lubricación</i>	Lubrificação	润滑油	B4
Dati Tecnici 50 Hz	<i>Technical data 50 Hz</i>	Technische Daten 50 Hz	<i>Datos técnicos 50 Hz</i>	Dados Tecnicos 50 Hz	技术参数 50Hz	B5
Dati Tecnici 60 Hz	<i>Technical data 60 Hz</i>	Technische Daten 60 Hz	<i>Datos técnicos 60 Hz</i>	Dados Tecnicos 60 Hz	技术参数 60Hz	B6
Motori Applicabili	<i>IEC Motor adapters</i>	IEC Motoradapter	<i>Motores aplicables</i>	Motores aplicáveis	IEC电机适配法兰	B7
Dimensioni	<i>Dimensions</i>	Abmessungen	<i>Dimensiones</i>	Dimensões	尺寸规格	B8

Questa sezione annulla e sostituisce ogni precedente edizione o revisione. Qualora questa sezione non Vi sia giunta in distribuzione controllata, l'aggiornamento dei dati ivi contenuto non è assicurato. **In tal caso la versione più aggiornata è disponibile sul nostro sito internet www.transtecno.com**

This section replaces any previous edition and revision. If you obtained this catalogue other than through controlled distribution channels, the most up to date content is not guaranteed. In this case the latest version is available on our web site www.transtecno.com

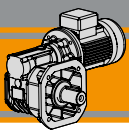

POK

Motoriduttori a vite senza fine Wormgearmotors

Descrizione	Description	Beschreibung	Descripción	Descrição	介绍
<p>I motoriduttori POK sono stati pensati per le linee di alimentazione negli allevamenti. Sono motoriduttori a vite senza fine progettati per fissaggio universale.</p>	<p>POK gearmotors have been designed for livestock feeding lines. They are wormgear-motors designed for universal fixing.</p>	<p>Die POK Getriebemotoren sind für Fütterungsanlagen im Mastbetrieb konzipiert. Sie sind Schneckengetriebemotoren für Universalmontage.</p>	<p>Los motorreductores de la serie POK han sido pensados para las líneas de alimentación en las granjas. Son motorreductores de visinfín contruidos con fijación universal.</p>	<p>Os motoredutores POK foram pensados para as linhas de alimentação nas criações de animais. São motoredutores de rosca sem fim projetados para uma fixação universal.</p>	<p>POK减速机运用在家畜喂养线上。POK产品属于蜗轮蜗杆减速电机，可普遍安装。</p>
<p>Le principali caratteristiche sono:</p> <ul style="list-style-type: none"> • carcassa in alluminio • flangia uscita personalizzabile e integrale, fissaggio direttamente alla cassa per una maggiore sopportazione dei carichi • albero uscita integrale personalizzabile per una maggiore resistenza ai carichi • lubrificazione a vita • coperchio chiuso in pressofusione di alluminio 	<p>The main features are:</p> <ul style="list-style-type: none"> • aluminium housing • customisable integral output flange, fixed directly to the housing, to withstand higher loads • customisable integral output shaft for greater load-bearing capacity • long-life lubrication • die-cast aluminium cover 	<p>Die Hauptmerkmale sind:</p> <ul style="list-style-type: none"> • Aluminiumgehäuse • Integrierte, anpassbare Abtriebsflansch. Anbau direkt am Gehäuse für größere Belastungen. • Integrierte, anpassbare Ausgangswelle für größere Belastungen. • Lebensdauer-schmierung • Aluminiumdruckgussdeckel 	<p>Las características principales son:</p> <ul style="list-style-type: none"> • Carcasa en aluminio • Brida de salida personalizable y solidaria, fijada directamente a la carcasa para soportar mejor las cargas • Eje de salida personalizable y solidario, para una mayor resistencia a las cargas • Lubricación permanente • Tapa de protección en aluminio 	<p>As principais características são:</p> <ul style="list-style-type: none"> • Carcaça de alumínio • Flange de saída personalizável e integral, fixação diretamente na carcaça para suportar mais ascargas • Eixo de saída personalizável e integral para uma maior solicitação das cargas • Lubrificação permanente • Tampa em pressofusão de alumínio 	<p>产品主要特点:</p> <ul style="list-style-type: none"> • 铝壳箱体 • 可按客户要求定制整体输出法兰，直接安装于箱体上，可承受更高负载。 • 若需更大承载能力，可按客户需求定制整体输出轴 • 长寿命合成油 • 压铸铝合金箱体

Flange d'entrata - Input flanges - Antriebsflansche - Bidas de entrada - Flange de entrada - 输入法兰
Sensi di rotazione - Direction of rotation - Drehrichtung - Sentido de rotación - Sentido de rotação - 运转方向

IEC 71B5
 IEC 80B5/B14
 IEC 90B5/B14
 IEC 100B5/B14
 IEC 112B5/B14

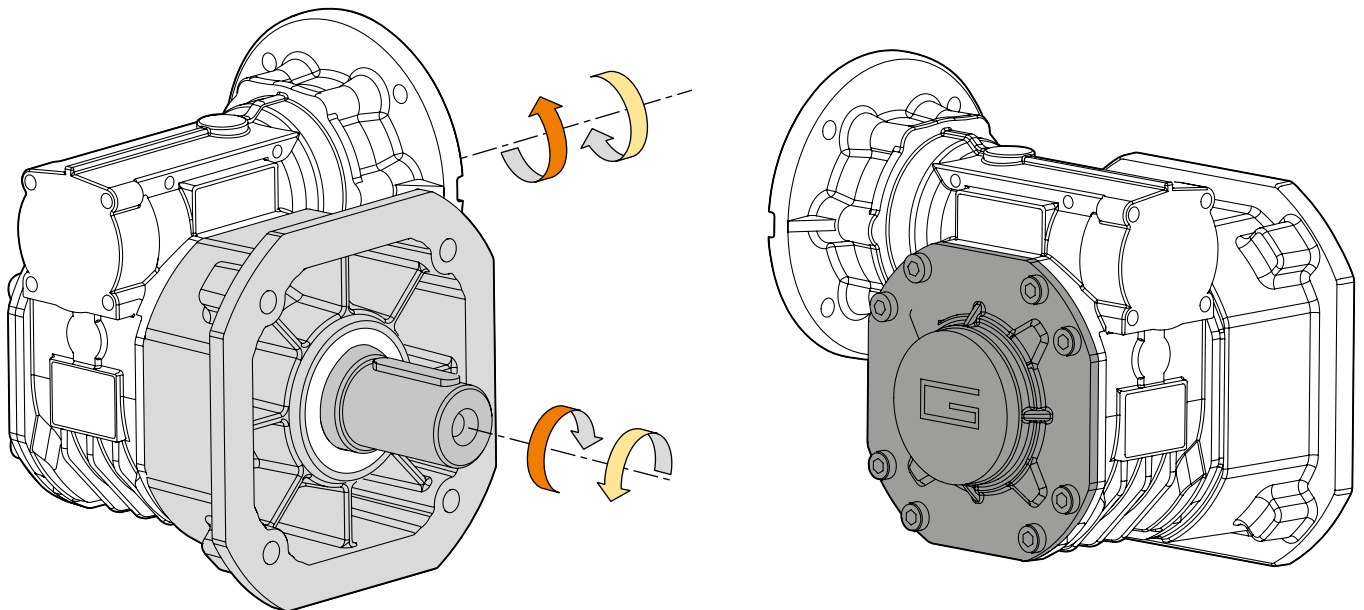

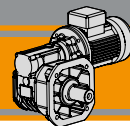

Flange d'uscita - Output flanges - Abtriebsflansche - Bidas de salida - Flange de saída - 输出法兰

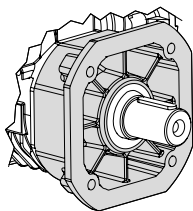

Realizzate a richiesta del cliente
Customizable upon request
Kundenanpassung auf Anfrage
Personalizable bajo petición del cliente
Projetada em base à necessidade do cliente
可按客户要求定制

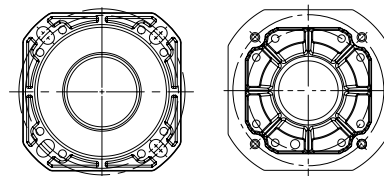

Alberi d'uscita - Output shafts - Abtriebswellen - Ejes de salida - Eixo de saída - 输出轴

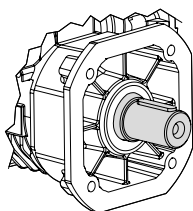

Realizzati a richiesta del cliente
Customizable upon request
Kundenanpassung auf Anfrage
Personalizable bajo petición del cliente
Projetada em base à necessidade do cliente
可按客户要求定制

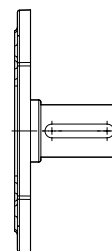

POK

Designazione Classification Klassifikation Clasificación Designação 选型

Riduttore / Gearbox / Getriebe / Reductor / Redutores / 减速机

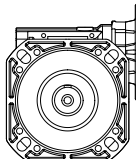
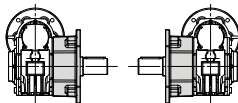
POK	150	FD	10	71	B5
Tipo Type Tip Tipo Tipo 种类	Grandezza Size Größe Tamaño Tamanho 型号	Versione riduttore Gearbox version Getriebeversion Versión reductor Versão reductor 置式	Rapporto Ratio Übersetzung Relación de reducción Redução 速比	IEC 	Forma costruttiva Version Bauform Forma Constructiva Forma Constructiva 型号
	150 220	FD FS 	Vedi tabelle See tables Siehe Tabellen Vease tablas Ver tabela 见表格	71.. — 112..	B5 B14

Motore / Motor / Motor / Motor / Motor / 电机

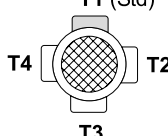
0.75kW	4p	3ph	230/400V	50Hz	T1
Potenza Power Leistung Potencia Potência 功率	Poli Poles Pole Polos Polos 极数	Fasi Phases Phasen Fases Fases 相数	Tensione Voltage Spannung Tensión Tensão 电压	Frequenza Frequency Frequenz Frecuencia Frequência 频率	Pos. morsettiera Terminal box pos. Position Klemmenkasten Posición Caja de Bornes Posição Bloco terminal 接线盒位置
Vedi tabelle See tables Siehe Tabellen Vease tablas Ver tabela 见表格	2p 4p 6p 8p	1ph 3ph	230/400V 220/380V ... 230V ...	50Hz 60Hz	T1 (Std)  T4 T2 T3



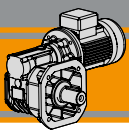

Simbologia	Symbols	Symbole	Simbología	Simbologia	代号说明	
n_1 [min ⁻¹]	Velocità in ingresso	<i>Input speed</i>	Eingangsdrehzahl	<i>Velocidad de entrada</i>	Velocidade de entrada	输入转速
n_2 [min ⁻¹]	Velocità in uscita	<i>Output speed</i>	Ausgangsdrehzahl	<i>Velocidad de salida</i>	Velocidade de saída	输出转速
i	Rapporto di riduzione	<i>Ratio</i>	Übersetzung	<i>Relación de reducción</i>	Relação de redução	速比
P_1 [kW]	Potenza in ingresso	<i>Input power</i>	Eingangsleistung	<i>Potencia en entrada</i>	Potência de entrada	输入功率
P_{n1} [kW]	Potenza nominale in entrata	<i>Nominal input power</i>	Nenn-Eingangsleistung	<i>Potencia nominal de entrada</i>	Potência nominal na entrada	额定输入功率
M_2 [Nm]	Coppia nominale	<i>Nominal torque</i>	Nennmoment	<i>Par nominal</i>	Torque	额定扭矩
M_{n2} [Nm]	Coppia nominale in uscita in funzione di P_{n1}	<i>Nominal output torque referred to P_{n1}</i>	NennAusgangsdrehmoment in Abhängigkeit von P_{n1}	<i>Par nominal de salida en función de P_{n1}</i>	Torque nominal na saída em função de P_{n1}	额定输出扭矩 见 P_{n1}
sf	Fattore di servizio	<i>Service factor</i>	Servicefaktor	<i>Factor de servicio</i>	Fator de serviço	使用系数
R_d [%]	Rendimento dinamico	<i>Dynamic efficiency</i>	Dynamischer Wirkungsgrad	<i>Rendimiento dinámico</i>	Rendimento dinâmico	/动态效率
R_s [%]	Rendimento statico	<i>Static efficiency</i>	Statischer Wirkungsgrad	<i>Rendimiento estático</i>	Rendimento estático	静态效率
R_2 [N]	Carico radiale ammissibile in uscita	<i>Permitted output radial load</i>	Zulässige radiale Belastung	<i>Carga radial permitida en salida</i>	Carga radial admissível na saída	输出径向负荷

Lubrificazione	Lubrication	Schmierung	Lubricación	Lubrificação	润滑油
----------------	-------------	------------	-------------	--------------	-----

I motoriduttori POK sono forniti completi di lubrificante sintetico viscosità 320 e non necessitano di manutenzione.

Permanent synthetic oil long-life lubrication (viscosity grade 320) on POK gearmotors.

Dauerschmierung mit Long-life Synthetiköl (Viskositätsgrad 320) für Getriebemotoren POK.

Los motorreductores POK se proporcionan completos de lubricante sintético viscosidad 320 y no necesitan mantenimiento.

Os motoredutores POK são fornecidos já com lubrificante sintético, com viscosidade de 320 não necessitando.

POK减速电机使用长寿命人工合成润滑油（粘度为320）。

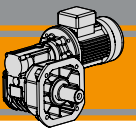

[IEC - 50 Hz - n₁ 1400 min⁻¹]

P ₁ [kW]	n ₂ [min ⁻¹]	M ₂ [Nm]	sf	i		
------------------------	--	------------------------	----	---	---	---

P ₁ [kW]	n ₂ [min ⁻¹]	M ₂ [Nm]	sf	i		
------------------------	--	------------------------	----	---	---	---

0.55

71C4 (1400 min ⁻¹)	140	33	6.7	10	POK150	B5	
	93	48	4.6	15		B5	
	70	61	3.3	20		B5	
	56	75	2.4	25		B5	
	47	85	2.8	30		B5	
	35	108	1.9	40		B5	
	28	128	1.5	50		B5	
	23	146	1.2	60		B5	
	47	89	4.7	30		POK220	B5
	35	114	3.3	40			B5
28	135	2.4	50	B5			
23	155	2.0	60	B5			

1.1

80C4 90S4 (1400 min ⁻¹)	140	66	3.3	10	POK150	B5/B14	
	93	95	2.3	15		B5/B14	
	70	123	1.6	20		B5/B14	
	56	149	1.2	25		B5/B14	
	47	171	1.4	30		B5/B14	
	35	216	1.0	40		B5/B14	
	93	97	3.8	15		POK220	B5/B14
	70	126	2.8	20			B5/B14
	56	156	2.0	25			B5/B14
	47	178	2.4	30			B5/B14
35	228	1.6	40	B5/B14			
28	270	1.2	50	B5/B14			
23	311	1.0	60	B5/B14			

80A4 (1400 min ⁻¹)	140	33	6.7	10	POK150	B5/B14	
	93	48	4.6	15		B5/B14	
	70	61	3.3	20		B5/B14	
	56	75	2.4	25		B5/B14	
	47	85	2.8	30		B5/B14	
	35	108	1.9	40		B5/B14	
	28	128	1.5	50		B5/B14	
	23	146	1.2	60		B5/B14	
	47	89	4.7	30		POK220	B5/B14
	35	114	3.3	40			B5/B14
28	135	2.4	50	B5/B14			
23	155	2.0	60	B5/B14			

1.5

90L4 (1400 min ⁻¹)	140	89	2.4	10	POK150	B5/B14	
	93	130	1.7	15		B5/B14	
	70	168	1.2	20		B5/B14	
	56	204	0.9	25		B5/B14	
	47	233	1.0	30		B5/B14	
	35	295	0.8	40		B5/B14	
	140	91	3.6	10		POK220	B5/B14
	93	132	2.8	15			B5/B14
	70	172	2.1	20			B5/B14
	56	212	1.5	25			B5/B14
47	243	1.7	30	B5/B14			
35	311	1.2	40	B5/B14			
28	368	0.9	50	B5/B14			

0.75

71D4 (1400 min ⁻¹)	140	45	4.9	10	POK150	B5	
	93	65	3.4	15		B5	
	70	84	2.4	20		B5	
	56	102	1.8	25		B5	
	47	117	2.1	30		B5	
	35	147	1.4	40		B5	
	28	174	1.1	50		B5	
	23	200	0.9	60		B5	
	70	86	4.1	20		POK220	B5
	56	106	3.0	25			B5
47	121	3.5	30	B5			
35	156	2.4	40	B5			
28	184	1.8	50	B5			
23	212	1.4	60	B5			

2.2

90LB4 100LA4 (1400 min ⁻¹)	140	131	1.7	10	POK150	B5/B14	
	93	190	1.2	15		B5/B14	
	70	246	0.8	20		B5/B14	
	140	134	2.5	10		POK220	B5/B14
	93	194	1.9	15			B5/B14
	70	252	1.4	20			B5/B14
	56	311	1.0	25			B5/B14
	47	356	1.2	30			B5/B14
	35	456	0.8	40			B5/B14

80B4 (1400 min ⁻¹)	140	45	4.9	10	POK150	B5/B14	
	93	65	3.4	15		B5/B14	
	70	84	2.4	20		B5/B14	
	56	102	1.8	25		B5/B14	
	47	117	2.1	30		B5/B14	
	35	147	1.4	40		B5/B14	
	28	174	1.1	50		B5/B14	
	23	200	0.9	60		B5/B14	
	70	86	4.1	20		POK220	B5/B14
	56	106	3.0	25			B5/B14
47	121	3.5	30	B5/B14			
35	156	2.4	40	B5/B14			
28	184	1.8	50	B5/B14			
23	212	1.4	60	B5/B14			

3



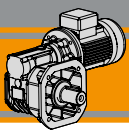

100LB4 (1400 min ⁻¹)	140	179	1.2	10	POK150	B5/B14	
	93	259	0.9	15		B5/B14	
	140	182	1.8	10		POK220	B5/B14
	93	264	1.4	15			B5/B14
	70	344	1.0	20			B5/B14
	56	425	0.8	25			B5/B14
	47	485	0.9	30			B5/B14

4

112M4 (1400 min ⁻¹)	140	238	0.9	10	POK150	B5/B14
	140	243	1.4	10	POK220	B5/B14
	93	352	1.1	15		B5/B14
	70	458	0.8	20		B5/B14



[IEC - 60 Hz - n_1 1750 min⁻¹]

P_1 [kW]	n_2 [min ⁻¹]	M_2 [Nm]	sf	i			P_1 [kW]	n_2 [min ⁻¹]	M_2 [Nm]	sf	i					
0.55							1.1									
71C4 (1750 min ⁻¹)	175	27	7.3	10	POK150	B5	80C4 90S4 (1750 min ⁻¹)	175	53	3.6	10	POK150	B5/B14			
	117	38	4.7	15		B5		117	77	2.3	15		B5/B14			
	88	50	3.7	20		B5		88	100	1.8	20		B5/B14			
	70	60	2.7	25		B5		70	125	1.3	25		B5/B14			
	58	70	3.2	30		B5		58	140	1.6	30		B5/B14			
	44	89	2.2	40		B5		44	177	1.1	40		B5/B14			
	35	107	1.6	50		B5										
	29	124	1.3	60	B5											
		44	92	3.7	40	POK220		B5		117	77	4.4	15	POK220	B5/B14	
		35	111	2.7	50			B5		88	101	3.2	20		B5/B14	
		29	128	2.2	60			B5		70	126	2.3	25		B5/B14	
					B5			58	144	2.7	30	B5/B14				
								44	185	1.8	40	B5/B14				
								35	222	1.4	50	B5/B14				
								29	256	1.1	60	B5/B14				
0.75							1.5									
80A4 (1750 min ⁻¹)	175	27	7.3	10	POK150	B5/B14	90L4 (1750 min ⁻¹)	175	72	2.7	10	POK150	B5/B14			
	117	38	4.7	15		B5/B14		117	105	1.7	15		B5/B14			
	88	50	3.7	20		B5/B14		88	137	1.3	20		B5/B14			
	70	60	2.7	25		B5/B14		70	171	1.0	25		B5/B14			
	58	70	3.2	30		B5/B14		58	191	1.2	30		B5/B14			
	44	89	2.2	40		B5/B14		44	242	0.8	40		B5/B14			
	35	107	1.6	50		B5/B14										
	29	124	1.3	60	B5/B14											
		44	92	3.7	40	POK220		B5/B14		175	73	4.1	10	POK220	B5/B14	
		35	111	2.7	50			B5/B14		117	106	3.2	15		B5/B14	
		29	128	2.2	60			B5/B14		88	138	2.3	20		B5/B14	
					B5/B14			70	172	1.7	25	B5/B14				
								58	196	2.0	30	B5/B14				
								44	252	1.4	40	B5/B14				
								35	303	1.0	50	B5/B14				
2.2							2.2									
71D4 (1750 min ⁻¹)	175	36	5.3	10	POK150	B5	90LB4 100LA4 (1750 min ⁻¹)	175	106	1.8	10	POK150	B5/B14			
	117	52	3.4	15		B5		117	154	1.2	15		B5/B14			
	88	68	2.7	20		B5		88	201	0.9	20		B5/B14			
	70	85	1.9	25		B5										
	58	95	2.3	30		B5										
	44	121	1.6	40		B5										
	35	145	1.2	50		B5										
	29	170	1.0	60	B5											
		88	69	4.7	20	POK220		B5		175	107	2.8	10	POK220	B5/B14	
		70	86	3.4	25			B5		117	155	2.2	15		B5/B14	
		58	98	4.0	30			B5		88	202	1.6	20		B5/B14	
	44	126	2.7	40	B5			70	252	1.2	25	B5/B14				
	35	151	2.0	50	B5		58	288	1.4	30	B5/B14					
	29	174	1.6	60	B5		44	370	0.9	40	B5/B14					
3							3									
80B4 (1750 min ⁻¹)	175	36	5.3	10	POK150	B5/B14	100LB4 (1750 min ⁻¹)	175	145	1.3	10	POK150	B5/B14			
	117	52	3.4	15		B5/B14		117	210	0.9	15		B5/B14			
	88	68	2.7	20		B5/B14										
	70	85	1.9	25		B5/B14										
	58	95	2.3	30		B5/B14										
	44	121	1.6	40		B5/B14										
	35	145	1.2	50		B5/B14										
	29	170	1.0	60	B5/B14											
		88	69	4.7	20	POK220		B5/B14		175	146	2.1	10	POK220	B5/B14	
		70	86	3.4	25			B5/B14		117	211	1.6	15		B5/B14	
		58	98	4.0	30			B5/B14		88	275	1.2	20		B5/B14	
	44	126	2.7	40	B5/B14			70	344	0.8	25	B5/B14				
	35	151	2.0	50	B5/B14		58	393	1.0	30	B5/B14					
	29	174	1.6	60	B5/B14											
4							4									
112M4 (1750 min ⁻¹)	175	194	1.5	10	POK220	B5/B14	112M4 (1750 min ⁻¹)	175	194	1.5	10	POK220	B5/B14			
	117	282	1.2	15		B5/B14		117	282	1.2	15		B5/B14			
	88	367	0.9	20		B5/B14		88	367	0.9	20		B5/B14			

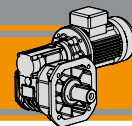

Motori applicabili IEC Motor adapters IEC Motoradapter Motores aplicables Motores aplicáveis IEC电机适配法兰

	IEC	N	M	P	D	i							
						10	15	20	25	30	40	50	60
POK150	100/112B5	180	215	250	28								
	100/112B14	110	130	160									
	90B5	130	165	200	24								
	90B14	95	115	140									
	80B5	130	165	200	19								
	80B14	80	100	120									
	71B5	110	130	160	14								
POK220	100/112B5	180	215	250	28								
	100/112B14	110	130	160									
	90B5	130	165	200	24								
	90B14	95	115	140									
	80B5	130	165	200	19								
	80B14	80	100	120									
	71B5	110	130	160	14								

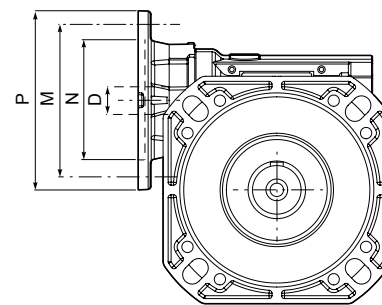

POK

Nota: Le aree evidenziate in grigio indicano l'applicabilità della corrispondente grandezza motore.
Flange NEMA disponibili a richiesta.

Note: Grey areas indicate motor inputs available on each size of unit.
NEMA flanges available on demand.

Hinweis: die grau markiert Bereiche zeigen die Anwendbarkeit der jeweiligen Motorgröße.
NEMA Flansche sind auf Anfrage erhältlich.

Nota: As áreas evidenciadas em cinza indicam a aplicabilidade da correspondente grandeza do motor.
Flange Nema disponível sob encomenda.

Note: Las áreas grises indican los tamaño de los motores aplicables.
Bridas NEMA están disponibles a petición.

注：灰色区域表示各个型号可用的电机输入。
如有需要，可使用NEMA法兰。

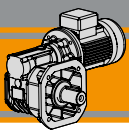

POK

Motoriduttori a vite senza fine Wormgearmotors

Dimensioni Dimensions Abmessungen Dimensiones Dimensões 尺寸规格

POK 150

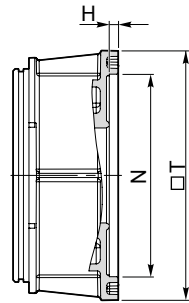
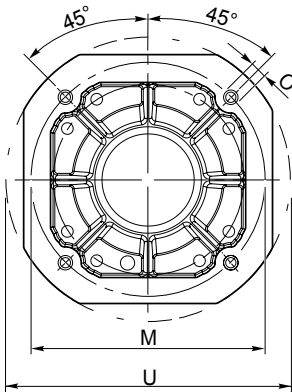
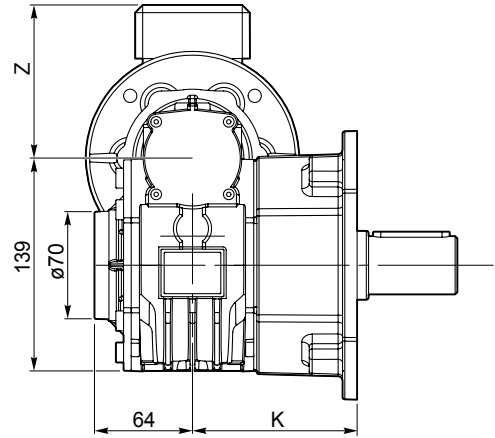
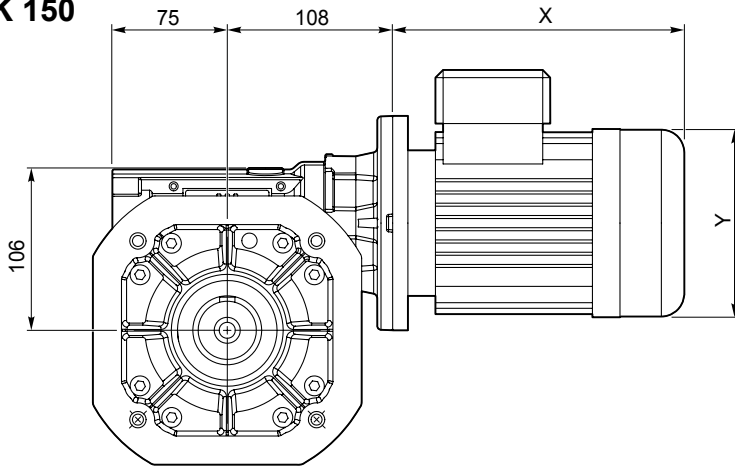

Dimensioni Dimensions Abmessungen Dimensiones Dimensões 尺寸规格		H	M	N f7	O	K	T	U
POK150	F1	-	ø165	-	N° 4 M12x24	115	□175	ø200.5

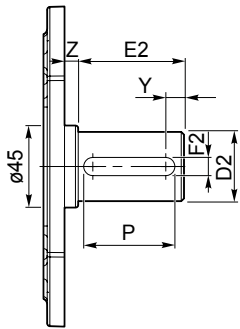

Dimensioni Dimensions Abmessungen Dimensiones Dimensões 尺寸规格		D2	E2	Y	F2	P	Z
POK150	S1	ø38	58	10	10	50	7.5

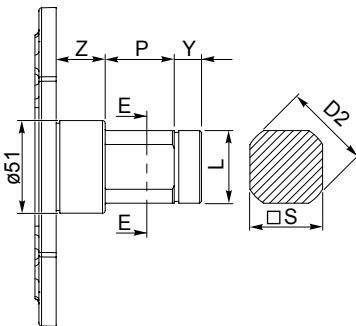

Dimensioni Dimensions Abmessungen Dimensiones Dimensões 尺寸规格		D2	Y	P	Z	L	S
POK150	S2	ø47	15	38	30	1 1/4 GAS	□40

Nota: Alberi e flange non in tabelle eseguibili a richiesta. Per informazioni sui carichi radiali contattare l'Ufficio Tecnico.

Note: Shafts and flanges not in table, customize on request. For information on radial loads please contact our Technical Assistance.

Anmerkung: Nicht in der Tabelle aufgeführte Wellen sind nach Kundenwunsch ausführbar. Für Informationen über die Radiallast, kontaktieren Sie bitte unsere technische Abteilung.

Nota: Ejes no incluidos en la tabla y realizables bajo pedido. Para obtener informaciones sobre las cargas radiales ponerse en contacto con el Departamento Técnico.

Nota: As eixos que não estão indicadas na tabela, estão disponíveis através de pedido. Para maiores informações sobre as cargas radiais, contate nosso escritório técnico

注解: 轴和法兰信息不在表格内, 如有客户需要, 可提供。有关径向负荷的信息, 请咨询我司技术部门。

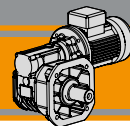

Dimensioni *Dimensions* Abmessungen *Dimensiones* Dimensões 尺寸规格

POK 220

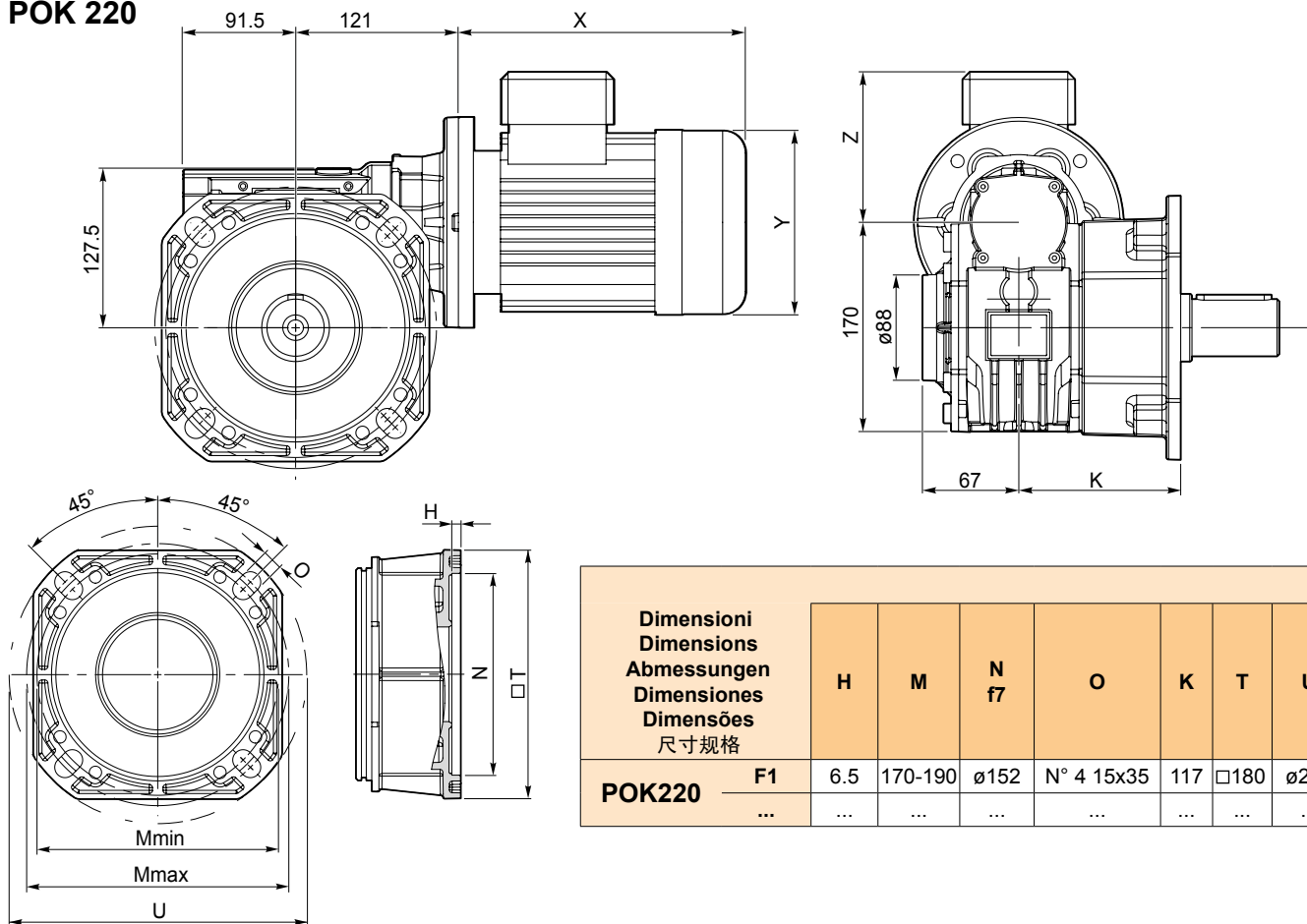

Dimensioni Dimensions Abmessungen Dimensiones Dimensões 尺寸规格		H	M	N f7	O	K	T	U
POK220	F1	6.5	170-190	ø152	N° 4 15x35	117	□180	ø215

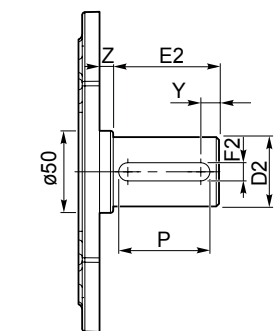

Dimensioni Dimensions Abmessungen Dimensiones Dimensões 尺寸规格		D2	E2	Y	F2	P	Z
POK220	S1	ø35	60	10	10	50	6

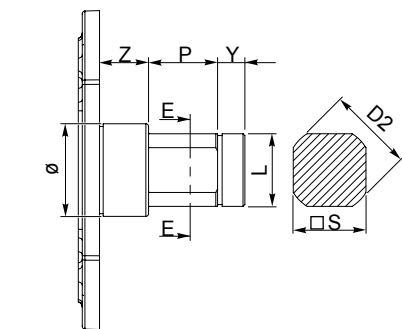

Dimensioni Dimensions Abmessungen Dimensiones Dimensões 尺寸规格		D2	Y	P	Z	L	S
POK220	S2

Nota: Alberi e flange non in tabelle eseguibili a richiesta. Per informazioni sui carichi radiali contattare l'Ufficio Tecnico.

Note: Shafts and flanges not in table, customize on request. For information on radial loads please contact our Technical Assistance.

Anmerkung: Nicht in der Tabelle aufgeführte Wellen sind nach Kundenwunsch ausführbar. Für Informationen über die Radiallast, kontaktieren Sie bitte unsere technische Abteilung.

Nota: Ejes no incluidos en la tabla y realizables bajo pedido. Para obtener informaciones sobre las cargas radiales ponerse en contacto con el Departamento Técnico.

Nota: As eixos que não estão indicadas na tabela, estão disponíveis através de pedido. Para maiores informações sobre as cargas radiais, contate nosso escritório técnico

注解: 轴和法兰信息不在表格内, 如有客户需要, 可提供。有关径向负荷的信息, 请咨询我司技术部门。

Poultry&Pig  **Tecno**
The gearmotors for farm equipment

Finecorsa rotativo
Rotary limit switch

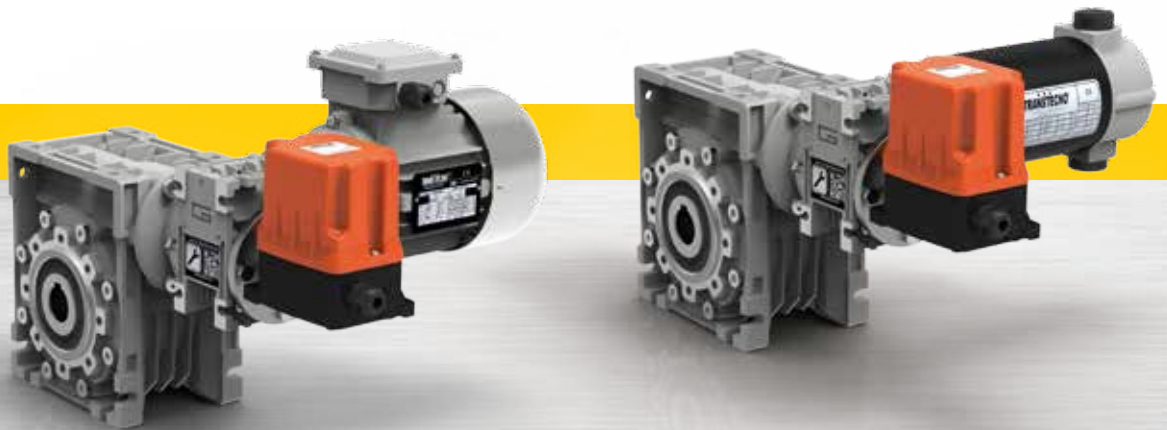

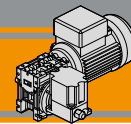

Indice	<i>Index</i>	Inhaltsverzeichnis	<i>Índice</i>	Índice	索引	Pagina Page Seite Página Pagina 页
Descrizione	<i>Description</i>	Beschreibung	<i>Descripción</i>	Descrição	介绍	C2
Designazione	<i>Classification</i>	Klassifikation	<i>Clasificación</i>	Designação	选型	C3
Scelta del fine corsa	<i>Choosing the limit switch</i>	Auswahl des Endschalers	<i>Selección del final de carrera</i>	Escolha do fim de curso	限位开关选型	C3
Regolazione	<i>Settings</i>	Einstellung	<i>Regulación</i>	Regulagem	设置	C6
Dimensioni	<i>Dimensions</i>	Abmessungen	<i>Dimensiones</i>	Dimensões	外形尺寸	C7
Caratteristiche aggiuntive	<i>Other features</i>	Weitere Eigenschaften	<i>Características adicionales</i>	Características adicionais	其它参数	C8

Questa sezione annulla e sostituisce ogni precedente edizione o revisione. Qualora questa sezione non Vi sia giunta in distribuzione controllata, l'aggiornamento dei dati ivi contenuto non è assicurato. **In tal caso la versione più aggiornata è disponibile sul nostro sito internet www.transtecno.com**

*This section replaces any previous edition and revision. If you obtained this catalogue other than through controlled distribution channels, the most up to date content is not guaranteed. **In this case the latest version is available on our web site www.transtecno.com***

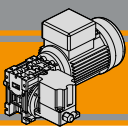

TOR

Fine corsa rotativo Rotary limit switch

Descrizione	Description	Beschreibung	Descripción	Descrição	介绍
-------------	-------------	--------------	-------------	-----------	----

Il finecorsa rotativo è un apparecchio utilizzato per controllare il movimento di macchine industriali. Viene collegato tramite il suo albero ad un riduttore in modo che, dopo un certo numero di giri, le camme intervengano sui microinteruttori permettendo di controllare uno spostamento predefinito.

The rotary limit switch is a device which allows you to control the movement of industrial machines. It's connected to the gearmotor with its shaft, so that, after a certain number of turns, the cams make the switches work, and then they can carry out their preset movement.

Der Dreh-Endschalter dient der Bewegungssteuerung von Maschinen im industriellen Einsatz. Über seine Welle wird er mit einem Getriebe verbunden, so dass nach einer bestimmten Anzahl von Umdrehungen die Nocken auf die Mikroschalter wirken und somit die Steuerung einer definierten Bewegung ermöglichen. Die Endschalter sind leicht zu montieren.

El final de carrera rotativo es un dispositivo utilizado para controlar el movimiento de las máquinas industriales. Se conecta a través de su eje a un reductor para que, después de un determinado número de revoluciones, las levas activen los micro-interruptores permitiendo controlar un desplazamiento predeterminado.

O fim de curso rotativo é um aparelho utilizado para controlar o movimento de máquinas industriais. Ele é conectado através eixo a um redutor de modo que, depois de um certo número de giros, os comes intervêm nos microinterruptores permitindo controlar um deslocamento predefinido.

旋转限位开关是用来控制工业机械运行的装置。它通过其传动轴连接于减速机上，当转过一定的圈数后，凸轮触头开关动作，从而实现预设的操作。

I fine corsa sono facilmente installabili sui vite senza fine CM030 (solo nella versione CMM), CM040, CM050 e CM063 tramite una apposita flangia.

Thanks to a special flange, the limit switches are easy to install on the wormgears CM030 (only CMM version), CM040, CM050 and CM063.

Mit einem entsprechenden Flansch werden sie mit Schneckengetrieben der Serien CM030 (nur in der Versione CMM), CM040, CM050 und CM063 verbunden.

Los finales de carrera pueden instalarse correctamente en los tornillos sinfin CM030 (sólo en la versión CMM), CM040, CM050 y CM063 a través de una brida específica.

Os fim de curso rotativos são facilmente instaláveis nas roscas sem fim CM030 (somente na versão CMM), CM040, CM050 e CM063 através de uma flange apropriada.

使用特殊连接法兰，限位开关可方便地安装在 CM030 (仅限于蜗轮蜗杆组合)、CM040、CM050 和 CM063 蜗轮蜗杆减速机上。

TOR è disponibile in due taglie TOR18 e TOR36. TOR18 può essere equipaggiato con soli contatti o solo potenziometro. TOR 36 può essere equipaggiato con soli contatti o con contatti e potenziometro.

TOR is available in two sizes TOR18 and TOR36. TOR18 can be fitted with just contacts or just a potentiometer. TOR 36 can be fitted with just contacts or with contacts and a potentiometer.

Die Dreh-Endschalter TOR sind in zwei Größen erhältlich: TOR18 und TOR36. Die Version TOR18 ist entweder mit Kontakten oder aber mit einem Potenziometer ausgestattet. Die Version TOR 36 ist entweder nur mit Kontakten ausgestattet oder aber mit Kontakten plus Potenziometer erhältlich.

TOR está disponible en dos tamaños TOR18 y TOR36. TOR18 puede estar equipado solo con contactos, o solo con potenciómetro. TOR 36 puede estar equipado solo con contactos o bien con contactos y potenciómetro.

TOR está disponível em dois tamanhos TOR18 e TOR36. TOR18 pode ser fornecido somente com contatos ou somente com potenciómetro. TOR 36 pode ser fornecido somente com contatos ou com contatos e potenciómetro.

TOR限位开关有两个型号：TOR18和TOR36。TOR18仅可和接触开关或一个电位器相配备。TOR36可单独配备接触开关或同时配备接触开关和电位器

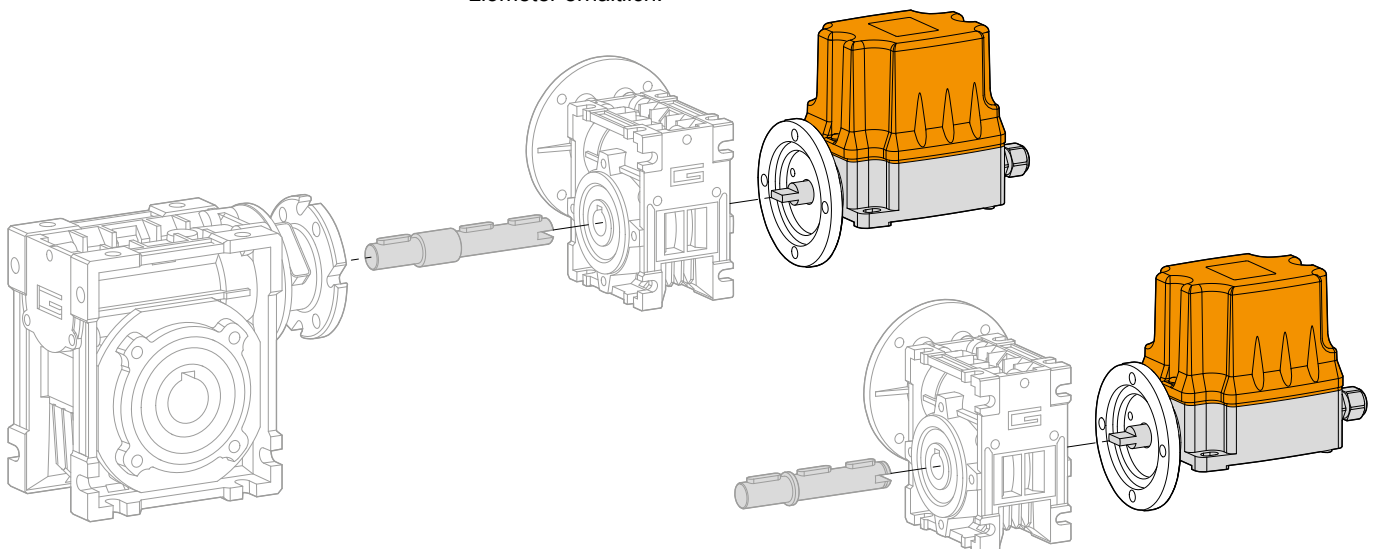

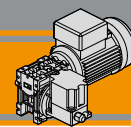

Designazione Classification Klassifikation Clasificación Designação 选型

Fine corsa / Limit switch / Endschalter/ Final de carrera / Fim de curso / 限位开关					
TOR36	100	D	2	K5	A
Tipo Type Tip Tipo Tipo 种类	Rapporto Ratio Übersetzung Relación de reducción Redução 速比	Tipo di contatti Contact type Kontakttyp Tipos de contactos Tipo de contatos 接触类型	Numero di contatti Number of contacts Anzahl Kontakte Número de contactos Número de contatos 接触开关的数量	Potenziometro Potentiometer Potenziometer Potenciómetro Potenciômetro 电位器	Profilo camma Cam profile Nockenprofil Perfil leva Perfil do came 凸轮形状
TOR 18	solo contatti only contacts nur Kontakte sólo contactos Somente com contatos 接触开关	R: Rapidi in deviazione Rapid deviation Schnelle Wechselkontakte Rápidos en la desviación Rápidos em desvio R: 快速偏置	2 (standard) 3 4	-	A (standard)
	solo potenziometro only potentiometer nur Potenziometer sólo potenciómetro Somente com potenciômetro 只配备电位器				
TOR36	solo contatti only contacts nur Kontakte sólo contactos Somente com contatos 接触开关	D: Rapidi in deviazione Rapid deviation Schnelle Wechselkontakte Rápidos en la desviación Rápidos em desvio D: 快速偏置	2 (standard) 3 4	-	B C D
	contatti + potenziometro contacts + potentiometer Kontakte + Potenziometer contactos + potenciómetro Contatos + potenciômetro 接触开关+电位器				

TOR

Scelta del fine corsa Choosing the limit switch Auswahl des Endschalers Selección del final de carrera Escolha do fim de curso 限位开关选型

Il punto di funzionamento dei microinterruttori viene stabilito con estrema precisione attraverso una corretta scelta delle caratteristiche del finecorsa: The microswitches operation point is established with extreme precision through the correct choice of these limit switch features: Der Betriebspunkt der Mikroschalter wird mit höchster Präzision durch gezielte Auswahl folgender Endschaltereigenschaften festgelegt: El punto de funcionamiento de los micro-interruptores se establece con mucha precisión a través de una correcta elección de las características del final de carrera: O ponto de funcionamento dos microinterruptores é estabelecido com extrema precisão através de uma escolha correta das características do fim de curso: 微动开关工作点的精确度建立在正确地选择限位开关的以下参数上:

- | | | | | | |
|--------------------------|--------------------|------------------|--------------------------|-----------------------|--|
| 1. rapporto di riduzione | 1. reduction ratio | 1. Untersetzung | 1. relación de reducción | 1. relação de redução | |
| 2. profilo della camma | 2. cam profile | 2. Nockenprofil | 2. perfil de la leva | 2. perfil do came | |
| 3. contatti | 3. contacts | 3. Kontakte | 3. contactos | 3. contatos | |
| 4. potenziometro | 4. potentiometer | 4. Potenziometer | 4. potenciómetro | 4. potenciômetro | |

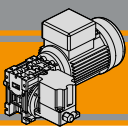

TOR

Fine corsa rotativo Rotary limit switch

1. Rapporto di riduzione

1. Reduction ratio

1. Untersetzung

1. Relación de reducción

1. Relação de redução

1. 减速比

Sono disponibili i rapporti di riduzione evidenziati nella tabella seguente:

The reduction ratios shown in the table below are available:

Die in nachfolgender Tabelle aufgeführten Untersetzungen sind verfügbar:

Están disponibles las relaciones de reducción descritas en la tabla siguiente:

Estão disponíveis as relações de redução evidenciadas na seguinte tabela:

减速比请见下表格

Rapporto di riduzione Reduction ratio Untersetzung Relación de reducción Relação de redução 减速比	5	7.5	10	12.5	15	25	35	50	70	75	100	140	150	175	200	275	400	550
TOR 18																		
TOR 36																		

2. Profilo della camma

2. Cam profile

2. Nockenprofil

2. Perfil de la leva

2. Perfil do came

2. 凸轮形状

Sono disponibili varie camme caratterizzate da diversi profili. Le camme con angoli di intervento più ampi sono indicate in applicazioni dove l'inerzia è più rilevante.

Various cams are available. Cams with wider operating angles are recommended for applications where inertia is more significant.

Die Endschalter können mit verschiedenen Nocken mit unterschiedlichen Profilen geliefert werden. Die Nocken mit größerem Schaltwinkel eignen sich insbesondere für Anwendungen mit höherer Trägheit.

Están disponibles distintas levas caracterizadas por perfiles diferentes. Las levas con ángulos de intervención más amplios se indican en aplicaciones donde la inercia es más relevante.

Estão disponíveis vários comes caracterizados por diversos perfis. Os comes com ângulos de intervenção mais amplos são indicados em aplicações em que a inércia é mais relevante.

有较宽控制角的凸轮可推荐使用在惯性较大的应用上

Tipo / Type Tip / Tipo Tipo / 种类	Angolo di intervento / Operating angles Schaltwinkel / Ángulo de intervención Ângulo de intervenção / 跳闸角度	Profilo camma / Cam profile Nockenprofil / Perfil de la leva Perfil do came / 凸轮形状	Colore camma / Cam colour Nockenfarbe / Color leva Cor do came / 凸轮颜色
A (standard)			Bianco / White Weiß / Blanco Branco / 白色
B			Grigio / Grey Grau / Gris Cinza / 灰色
C			Rosso / Red Rote / Rojo Vermelho / 红色
D			Bianco / White Weiß / Blanco Branco / 白色

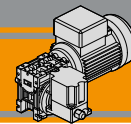

3. Contatti 3. Contacts 3. Kontakte 3. Contactos 3. Contatos 3. 接触开关

TOR18 e TOR36 sono standard nella versione a 2 contatti. Disponibili anche nella versione a 3 e a 4 contatti per la gestione delle posizioni intermedie.

TOR18 and TOR36 are standard in the 2-contact version. Also available in the 3 and 4 contact version for managing intermediate positions.

TOR18 und TOR36 sind standardmäßig mit 2 Kontakten ausgeführt. Sie sind jedoch auch mit 3 oder 4 Kontakten zwecks Steuerung von Zwischenstellungen erhältlich.

TOR18 y TOR36 tienen como versión estándar la de 2 contactos. Disponibles también en la versión de 3 y 4 contactos para la gestión de las posiciones intermedias.

TOR18 e TOR36 são padrões na versão com 2 contactos. Disponíveis também na versão de 3 e de 4 contactos para a gestão das posições intermédias.

TOR18-TOR36 标准产品带有2个接触开关，也可带3个和4个接触开关，用来控制中间位置。

4. Potenziometro 4. Potentiometer 4. Potenziometer 4. Potenciómetro 4. Potenciômetro 4. 电位器

L'utilizzo di un potenziometro permette di quantificare la rotazione dell'albero del finecorsa. Disponibile nella versione a 5 kΩ o 10 kΩ.

The potentiometer quantifies the limit switch shaft rotation.

Der Einsatz eines Potenziometers ermöglicht die Quantifizierung der Drehbewegung der Endschalterwelle. Es stehen die Ausführungen mit 5 kΩ oder 10 kΩ zur Verfügung.

El uso de un potenciómetro permite cuantificar la rotación del eje de final de carrera.

A utilização de um potenciômetro permite quantificar a rotação da eixos do fim de curso. Disponível na versão 5 kΩ ou 10 kΩ.

电位器可以量化限位开关的传动轴的转圈数。现有型号：K5 (5 kΩ)、10K (10 kΩ)。

Versions available: 5 kΩ or 10 kΩ.

Disponibles en la versión de 5 kΩ o 10 kΩ.

Caratteristiche potenziometro / Potentiometer features / Potenziometerdaten Características potenciómetro / Características do potenciômetro / 电位器参数						
Tolleranza di Rt a 20°C	Rt tolerance at 20°C	Widerstandstoleranz Rt bei 20°C	Tolerancia de Rt a 20°C	Tolerância de Rt a 20°C	Rt偏差	± 20%
Potenza massima dissipabile a 70°C	Maximum power dissipated at 70°C	Maximale Verlustleistung bei 70	Potencia máxima disipable a 70	Potência máxima dissipável de 70	最大功耗	0,3W
Angolo elettrico utile	Actual electric angle (AEA)	Elektrischer Drehwinkel	Ángulo eléctrico útil	Ângulo elétrico útil	实际电角度	≈ 335°
Vita del potenziometro (cicli)	Life (cycles)	Lebensdauer (Zyklen)	Vida del potenciómetro (ciclos)	Vida do potenciômetro (ciclos)	寿命 (周)	5 x 10 ⁶
Linearità indipendente	Independent linearity	Unabhängige Linearität	Linealidad independiente	Linearidade independente	独立线性	± 2%
Regolarità della tensione di uscita	Output voltage stability	Stabilität der Ausgangsspannung	Regularidad de la tensión de salida	Regulagem da tensão de saída	输出电压稳定性	0,1 % max
Corrente al cursore in S1	Cursor current (in cont. duty)	Schleiferstrom bei Betriebsart S1	Corriente al cursor en S1	Corrente no cursor em S1	游标电流 (连续工作制)	1mA max
Resistenza di carico sul contatto	Contact load resistance	Kontakt-Belastbarkeit	Resistencia de carga en el contacto	Resistência de carga no contato	接触负载电阻	> 1000 x Rt
Resistenza di isolamento	Insulation resistance	Isolationswiderstand	Resistencia de aislamiento	Resistência de isolamento	绝缘电阻	1000 MΩ – 500V _{cc}
Rigidità dielettrica	Dielectric rigidity	Durchschlagsfestigkeit	Rigidez dieléctrica	Rigidez elétrica	介电强度	> 500V _{eff} – 50Hz

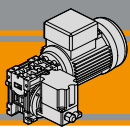

TOR

Fine corsa rotativo Rotary limit switch

Regolazione	Setting	Einstellung	Regulación	Regulagem	设置
-------------	---------	-------------	------------	-----------	----

1. Regolazione camme	1. Cam setting	1. Einstellung der Nocken	1. Regulación levas	1. Regulagem dos cames	1. 凸轮设置
----------------------	----------------	---------------------------	---------------------	------------------------	---------

Ogni camma è corredata di una propria vite di registro micrometrica.

La regolazione si effettua ruotando la vite di registro con un piccolo cacciavite a taglio.

Each cam is equipped with its own regulating screw.

Regulation can simply be carried out by rotating the regulating screw with a small blade screwdriver.

Jeder Nocken ist mit einer Feinstellschraube versehen.

Die Einstellung erfolgt durch Drehen der Feinstellschraube mit einem kleinen Schlitzschraubendreher.

Cada leva incorpora su tornillo de ajuste micrométrico.

La regulación se realiza girando el tornillo de ajuste con un pequeño destornillador de punta plana.

Cada came é equipado com um parafuso próprio de registro micrométrico.

A regulagem efectua-se girando o parafuso de registro com uma pequena chave de fenda cortante.

每个凸轮都配有调节螺钉，通过一字螺丝刀可简单地进行调节。



2. Regolazione potenziometro	2. Potentiometer setting	2. Einstellung des Potenziometers	2. Regulación potenciómetro	2. Regulagem do potenciômetro	2. 电位器设置
------------------------------	--------------------------	-----------------------------------	-----------------------------	-------------------------------	----------

Ogni potenziometro è dotato di una vite di bloccaggio (A) e di una ghiera di regolazione (B).

Il potenziometro segue il senso di rotazione delle camme. L'angolo elettrico totale utilizzabile sul potenziometro è di circa 335°.

Superata questa soglia si entra in una zona d'ombra in cui non può più essere garantito il controllo della macchina collegata al TOR.

Each potentiometer is equipped with a locking screw (A) and a regulation ring (B).

The potentiometer follows the cams rotation direction. The total electric angle that can be used on the potentiometer is about 335°.

Exceeding this threshold, you'll enter a grey area where cannot be guaranteed the control of the machine connected to the TOR.

Jedes Potenziometer ist mit einer Sicherungsschraube (A) und einem Stellring (B) versehen.

Das Potenziometer folgt der Drehrichtung der Nocken. Der nutzbare elektrische Drehwinkel des Potenziometers beträgt insgesamt ca. 335°.

Ist dieser Schwellenwert überschritten, beginnt eine Grauzone, in der die Steuerung der Maschine, an der der TOR-Endschalter eingesetzt wird, nicht mehr gewährleistet werden kann.

Cada potenciómetro incorpora un tornillo de bloqueo (A) y un anillo de ajuste (B).

El potenciómetro sigue el sentido de rotación de las levas. El ángulo eléctrico total utilizable en el potenciómetro es aprox. 335°.

Al superar este umbral, se pasa a una zona gris donde ya no es posible garantizar el control de la máquina conectada al TOR.

Cada potenciômetro é munido de um parafuso de bloqueio (A) e de uma porca de regulagem (B).

O potenciômetro segue o sentido de rotação dos cames. O ângulo elétrico total utilizável no potenciômetro é de aproximadamente 335°. Superado este limiar, entra-se numa zona de sombra em que não se pode mais garantir o controle da máquina conectada ao TOR.

每个电位器都装有锁紧螺钉(A)和调整环(B) 电位器跟着凸轮的旋转方向旋转 电位器的最大电角度约为335°。超过这个极限，会进入一个灰色区域，减速器可能会失去TOR的控制。

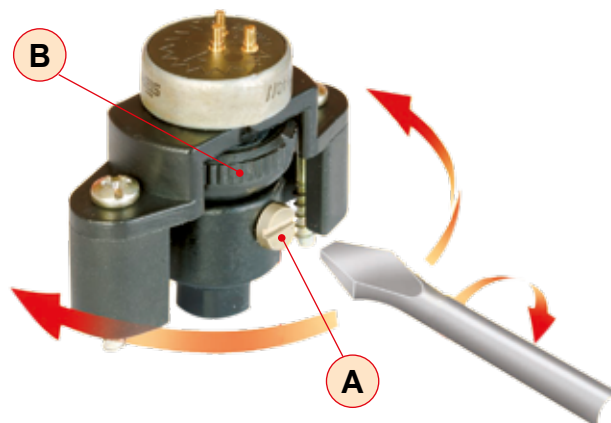

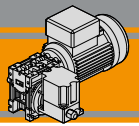

Dimensioni

Dimensions

Abmessungen

Dimensiones

Dimensões

外形尺寸

TOR 18

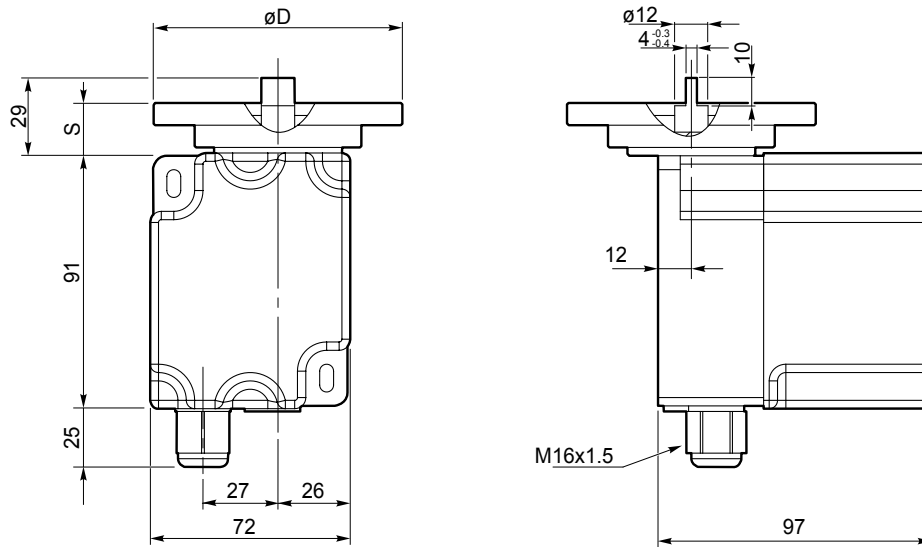

TOR 36

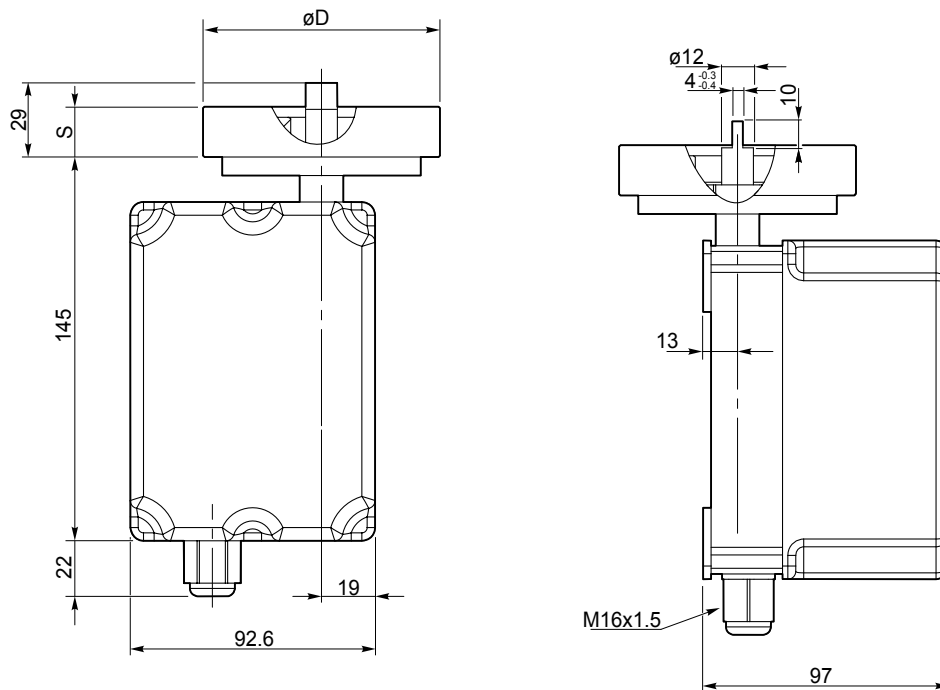

TOR

Riduttore Gearbox Getriebe Reductor Reductores 减速机	Dimensioni flangia / Flange dimensions / Flanschabmessungen / Dimensiones brida / Dimensões flange / 连接法兰尺寸	
	D	S
CM030	80	17
CM040	90	19
CM050	100	19
CM063	110	19.5

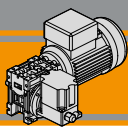

TOR

Fine corsa rotativo Rotary limit switch

**Caratteristiche
aggiuntive**

**Others
features**

**Weitere
Eigenschaften**

**Características
adicionales**

**Características
adicionais**

其它参数

Caratteristiche aggiuntive Other features Weitere Eigenschaften	Características adicionales Características adicionais 其它参数	TOR18	TOR36
Temperatura di funzionamento Operating temperature Betriebstemperatur	Temperatura de funcionamiento Temperatura de funcionamento 运行温度	-20 °C + + 60 °C	
Grado di protezione Protection degree Schutzart	Grado de protección Grau de proteção 防护等级	IP65	IP55
Base Lower casing Grundgehäuse	Base Base 下壳	nylon caricato reinforced nylon verstärktes Nylon en nylon reforzado de nylon reforçado 增强型尼龙	
Coperchio Cover Deckel	Tapa Tampa 盖子	termoplastico ad alta resistenza meccanica e termica high mechanical and thermal resistant thermoplastic Kunststoff mit hoher mechanischer und thermischer Belastbarkeit termoplástica de alta resistencia mecánica y térmica termoplástico com alta resistência mecânica e térmica 热塑性材料，具有高机械强度和热阻性。	
Pressacavo Cable gland Kabelverschraubung	Prensaestopa Prensa-cabo 電纜接頭	M16 x 1.5	
Peso Weight Gewicht	Peso Peso 重量	Max 500g (versione 2 contatti 2 contacts version version mit 2 Kontakten versión de 2 contactos versão 2 contatos 2个接触开关类型)	Max 700g (versione 2 contatti 2 contacts version version mit 2 Kontakten versión de 2 contactos versão 2 contatos 2个接触开关类型)
Durata meccanica dei contatti (numero di manovre) Mechanical lifetime (op) Mechanische Lebensdauer der Kontakte (Schaltzahl)	Duración mecánica de los contactos (número de maniobras) Duração mecânica dos contatos (número de manobras) 机械寿命	30 x 10 ⁶	2 x 10 ⁶
Conformita direttive CEE Compliance with EEC Directives Ausführung gemäß folgender EU-Richtlinien	Conformidad con las directivas CEE Conforme às Diretivas CEE 符合EEC的指令	98/37/CE 2006/95/CE	
Conformità alle norme Compliance with rules Ausführung gemäß folgender Normen	Conformidad con las normas Conforme às normas 符合的标准	CEI EN 60947-1; CEI EN 60947-5-1; CEI EN 60204-1; CEI EN 60529	
Tensione di isolamento Insulating voltage Isolationsspannung	Tensión de aislamiento Tensão de isolamento 绝缘电压	250 V ~	
Tensione massima di esercizio Maximum operating voltages Betriebsspannung max	Tensión máxima de servicio Tensão máxima de exercício 最高允许使用电压	250 V ~	
Protezione contro tensioni di contatto Protection against contact voltages Schutz gegen Berührungsspannung	Protección contra las tensiones de contacto Proteção contra tensões de contato 触点电压防护	a doppio isolamento CEI EN 60439-1 double insulation CEI EN 60439-1 mit doppelter Isolierung nach CEI EN 60439-1 de doble aislamiento CEI EN 60439-1 com duplo isolamento CEI EN 60439-1 双绝缘EN 60439-1	
Tensione di prova dei contatti Contact test voltage Kontakt-Prüfspannung	Tensión de ensayo de los contactos Tensão de prova dos contatos 触点测试电压	2000 V ~	
Categoria di utilizzo dei contatti Category of contacts usage Einsatzbereich der Kontakte	Categoria de uso de los contactos Categoria de utilização dos contatos 使用类别	AC15: 24Vac / 10.0A - 48Vac / 10.0A - 110Vac / 6.0A - 230Vac / 3.0A DC13: 24Vdc / 3.0A - 48Vdc / 1.5A - 110Vdc / 0.8A - 230Vdc / 0.4A	

Appendice
Appendix



Indice	<i>Index</i>	Inhaltsverzeichnis	<i>Índice</i>	Índice	索引	Pagina Page Seite Pàgina Pagina 页
Lista parti ricambi	<i>Spare parts list</i>	Ersatzteilliste	<i>Lista de requestos</i>	Listas peças de troca	零部件清单	
PU	<i>PU</i>	PU	<i>PU</i>	PU	PU	D2
POK	<i>POK</i>	POK	<i>POK</i>	POK	POK	D3
TOR	<i>TOR</i>	TOR	<i>TOR</i>	TOR	TOR	D4
Note	<i>Notes</i>	Hinweis	<i>Nota</i>	Note	注解	D5

Questa sezione annulla e sostituisce ogni precedente edizione o revisione. Qualora questa sezione non Vi sia giunta in distribuzione controllata, l'aggiornamento dei dati ivi contenuto non è assicurato. **In tal caso la versione più aggiornata è disponibile sul nostro sito internet www.transtecno.com**

*This section replaces any previous edition and revision. If you obtained this catalogue other than through controlled distribution channels, the most up to date content is not guaranteed. **In this case the latest version is available on our web site www.transtecno.com***

Liste parti di ricambio Spare parts list

Lista parti
ricambio

Spare parts
list

Ersatzteilliste

Lista de
requestos

Listas peças
de troca

零部件清单

PU

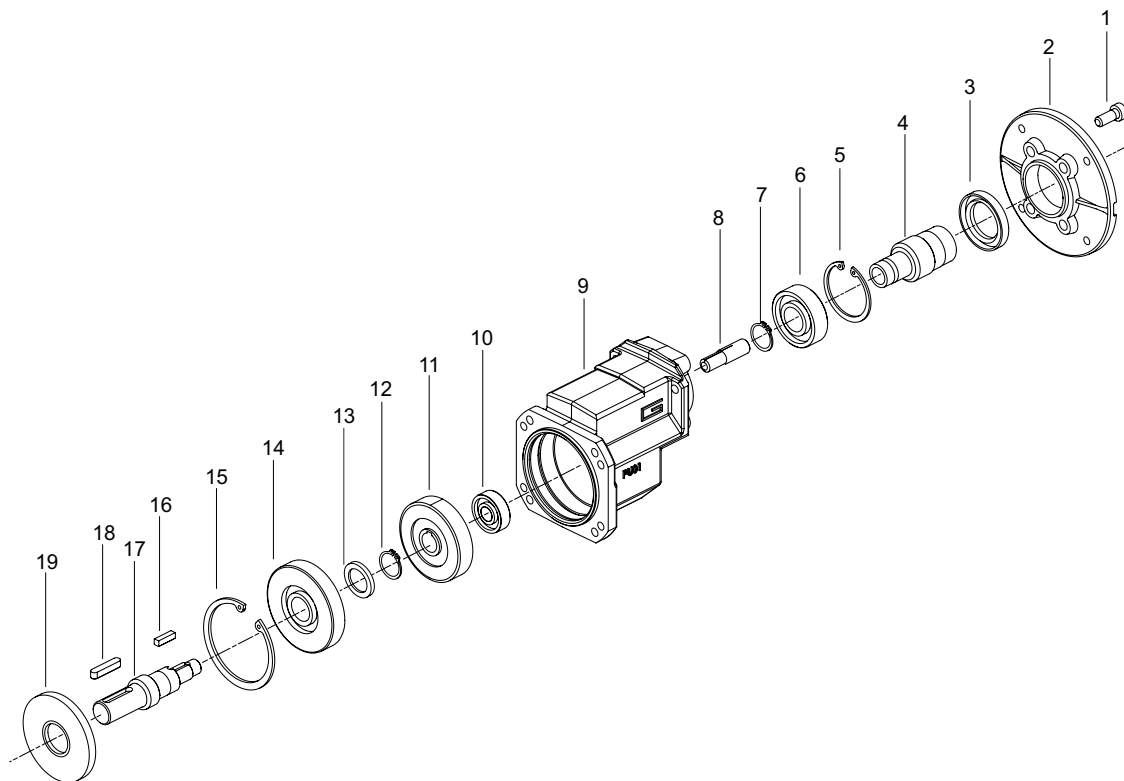

PU	Anelli di tenuta / Oil seals / Dichtungsringe Anillos aceite / Anéis / 油封	
	3	19
01	30/47/7	25/72/7

POK150..POK220

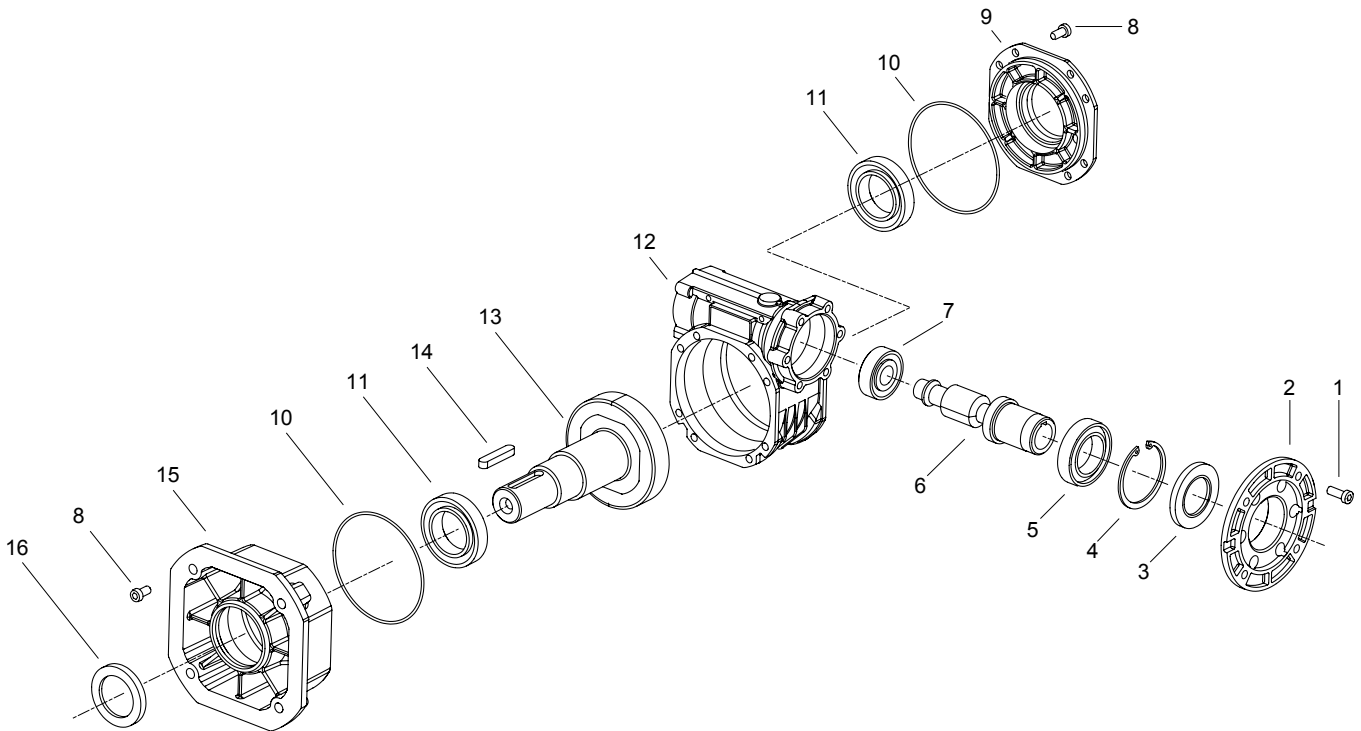

POK	Anelli di tenuta / Oil seals / Dichtungsringe Anillos aceite / Anéis / 油封	
	3	16
150	P40/68/07 TC	A richiesta / On request auf Anfrage / Bajo pedido A pedido / 可按要求定制
220		

TOR

CMM... TOR...

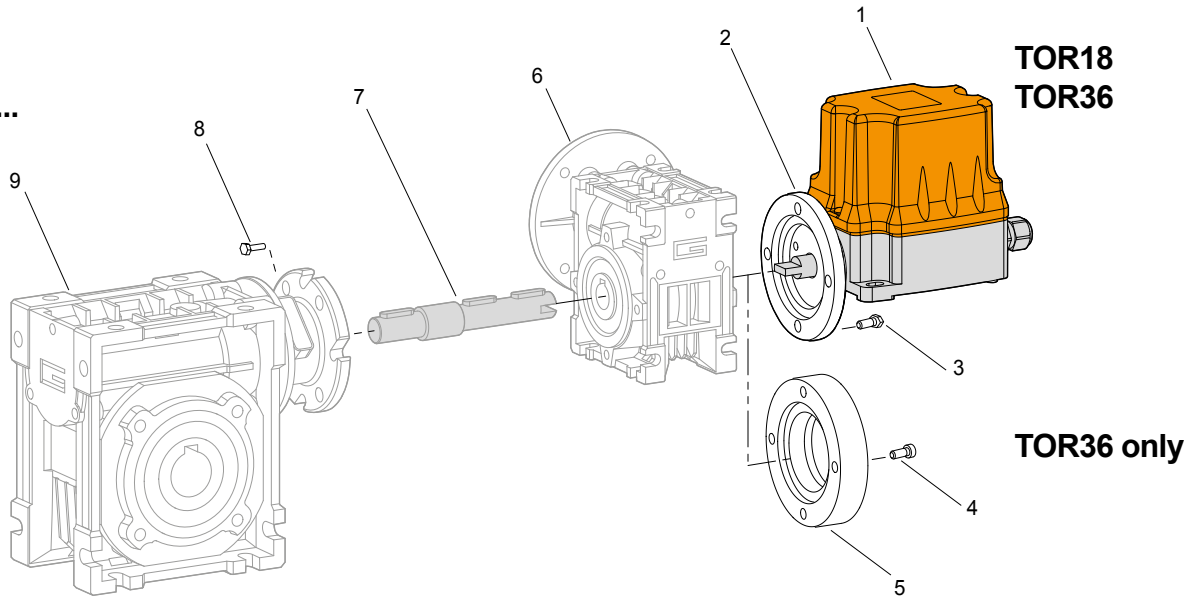

CM... TOR...

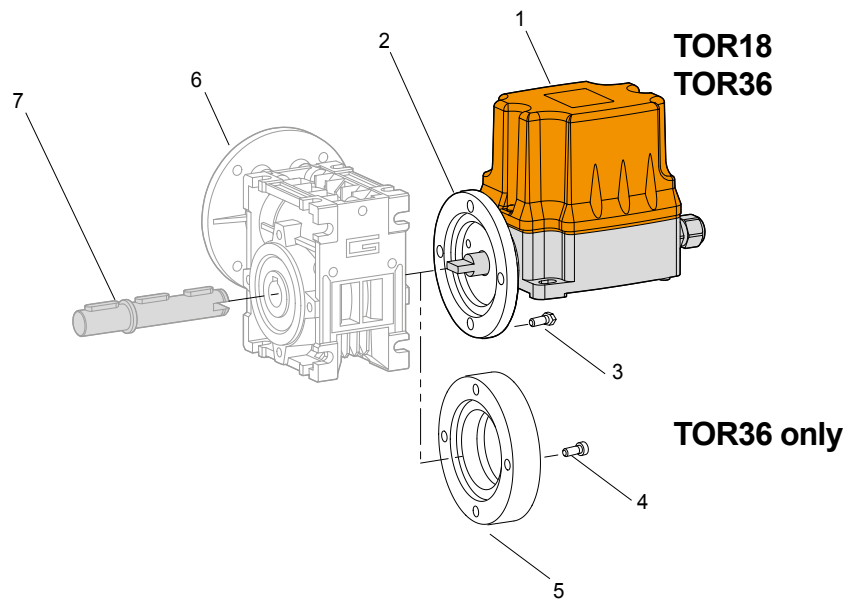

The **gearmotors** for farm equipment



**La gamma Poultry&PigTecno è completata dai motoriduttori Alu - Iron - Robin:
per maggiori informazioni contatta il nostro Ufficio Commerciale**

**The Poultry&PigTecno range is completed by the Alu - Iron - Robin gearmotors available in stock:
for additional information please contact our Sales Dept.**

**The Poultry&PigTecno Produktpalette wird durch die Alu - Iron - Robin Getriebemotoren auf Lager abgerundet:
für weitere Informationen kontaktieren Sie bitte unsere Verkaufsabteilung.**

**La gama Poultry&PigTecno queda completada con los motorreductores Alu - Iron - Robin:
para más información contactar con nuestro Departamento Comercial**

**A gama Poultry&PigTecno é completada pelos motoredutores Alu - Iron - Robin:
Para maiores informações, entre em contato com o nosso Escritório Comercial**

**Poultry&PigTecno 畜牧业产品系列可在Alu-Iron-Robin系列减速电机样本中查询，为我司常规产品。
如需更多信息，请联系我司销售部。**